



**THE DATASHEET OF
ADG774ABRQZ**



FEATURES

Bandwidth: >400 MHz

Low insertion loss and on resistance: 2.2 Ω typical

On resistance flatness: 0.3 Ω typical

Single 3 V/5 V supply operation

Very low distortion: <0.3%

Low quiescent supply current: 1 nA typical

Fast switching times

$t_{ON} = 6$ ns

$t_{OFF} = 3$ ns

TTL-/CMOS-compatible

Pb-free packages

16-lead QSSOP

16-lead 3 mm \times 3 mm body LFCSP

GENERAL DESCRIPTION

The [ADG774A](#) is a monolithic CMOS device comprising four 2:1 multiplexer/demultiplexers with high impedance outputs. The CMOS process provides low power dissipation yet offers high switching speed and low on resistance. The on resistance variation is typically less than 0.5 Ω over the input signal range.

The bandwidth of the [ADG774A](#) is typically 400 MHz and this, coupled with low distortion (typically 0.3%), makes the part suitable for switching of high speed data signals.

The on resistance profile is very flat over the full analog input range ensuring excellent linearity and low distortion. CMOS construction ensures ultralow power dissipation.

The [ADG774A](#) operates from a single 3.3 V/5 V supply and is TTL logic-compatible. The control logic for each switch is shown in the truth table (see Table 5).

FUNCTIONAL BLOCK DIAGRAM

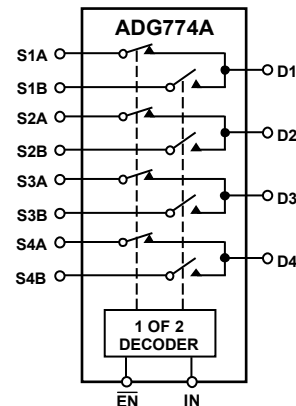

Figure 1.

These switches conduct equally well in both directions when on. In the off condition, signal levels up to the supplies are blocked. The [ADG774A](#) switches exhibit break-before-make switching action.

PRODUCT HIGHLIGHTS

1. Wide bandwidth data rates of >400 MHz.
2. Ultralow power dissipation.
3. Low leakage over temperature.
4. Break-before-make switching prevents channel shorting when the switches are configured as a multiplexer.
5. Crosstalk is typically -70 dB @ 10 MHz.
6. Off isolation is typically -65 dB @ 10 MHz.
7. Available in compact 3 mm \times 3 mm LFCSP.

TABLE OF CONTENTS

Features	1	ESD Caution.....	5
Functional Block Diagram	1	Pin Configurations and Function Descriptions	6
General Description	1	Typical Performance Characteristics	7
Product Highlights	1	Test Circuits.....	9
Revision History	2	Terminology	11
Specifications.....	3	Application Circuits	12
Single Supply	3	Outline Dimensions	13
Absolute Maximum Ratings.....	5	Ordering Guide	13

REVISION HISTORY

4/16—Rev. B to Rev. C

Changed CP-16-3 to CP-16-27	Throughout
Changes to Figure 3 and Table 4.....	6
Updated Outline Dimensions	13
Changes to Ordering Guide	13

8/06—Rev. A to Rev. B

Updated Format.....	Universal
Added LFCSP Model.....	Universal
Added Lead-Free Models	Universal
Changes to Table 3.....	5
Updated Outline Dimensions	13
Changes to Ordering Guide	13

4/03—Rev. 0 to Rev. A

Changes to TPCs 9–11	5
Updated Outline Dimensions	8

7/01—Revision 0: Initial Version

SPECIFICATIONS

SINGLE SUPPLY

$V_{DD} = 5\text{ V} \pm 10\%$, $GND = 0\text{ V}$, all specifications T_{MIN} to T_{MAX} , unless otherwise noted.¹

Table 1.

Parameter	B Version		Unit	Test Conditions/Comments
	25°C	T_{MIN} to T_{MAX}		
ANALOG SWITCH				
Analog Signal Range		0 to 2.5	V	
On Resistance, R_{ON}	2.2		Ω typ	$V_D = 0\text{ V}$ to 1 V , $I_S = -10\text{ mA}$
	3.5	4	Ω max	
On Resistance Match Between Channels, ΔR_{ON}	0.15		Ω typ	$V_D = 0\text{ V}$ to 1 V , $I_S = -10\text{ mA}$
		0.5	Ω max	
On Resistance Flatness, $R_{FLAT(ON)}$	0.3		Ω typ	$V_D = 0\text{ V}$ to 1 V , $I_S = -10\text{ mA}$
		0.6	Ω max	
LEAKAGE CURRENTS				
Source Off Leakage, I_S (OFF)	± 0.001		nA typ	$V_D = 3\text{ V}/1\text{ V}$, $V_S = 1\text{ V}/3\text{ V}$, see Figure 17
	± 0.1	± 0.25	nA max	
Drain Off Leakage, I_D (OFF)	± 0.001		nA typ	$V_D = 3\text{ V}/1\text{ V}$, $V_S = 1\text{ V}/3\text{ V}$, see Figure 17
	± 0.1	± 0.25	nA max	
Channel On Leakage, I_D , I_S (ON)	± 0.001		nA typ	$V_D = V_S = 3\text{ V}/1\text{ V}$, see Figure 18
	± 0.1	± 0.25	nA max	
DIGITAL INPUTS				
Input High Voltage, V_{INH}		2.4	V min	
Input Low Voltage, V_{INL}		0.8	V max	
Input Current				
I_{INL} or I_{INH}	0.001		μA typ	$V_{IN} = V_{INL}$ or V_{INH}
		± 0.1	μA max	
Digital Input Capacitance, C_{IN}		3	pF typ	
DYNAMIC CHARACTERISTICS²				
t_{ON} , $t_{ON}(\overline{EN})$		6	ns typ	$C_L = 35\text{ pF}$, $R_L = 50\ \Omega$, $V_S = 2\text{ V}$, see Figure 22
		12	ns max	
t_{OFF} , $t_{OFF}(\overline{EN})$		3	ns typ	$C_L = 35\text{ pF}$, $R_L = 50\ \Omega$, $V_S = 2\text{ V}$, see Figure 22
		6	ns max	
Break-Before-Make Time Delay, t_D		3	ns typ	$C_L = 35\text{ pF}$, $R_L = 50\ \Omega$, $V_{S1} = V_{S2} = 2\text{ V}$, see Figure 23
		1	ns min	
Off Isolation		-65	dB typ	$f = 10\text{ MHz}$, $R_L = 50\ \Omega$, see Figure 20
Channel-to-Channel Crosstalk		-70	dB typ	$f = 10\text{ MHz}$, $R_L = 50\ \Omega$, see Figure 21
Bandwidth -3 dB		400	MHz typ	$R_L = 50\ \Omega$, see Figure 19
Distortion		0.3	% typ	$R_L = 100\ \Omega$
Charge Injection		6	pC typ	$C_L = 1\text{ nF}$, see Figure 24, $V_S = 0\text{ V}$
C_S (OFF)		5	pF typ	
C_D (OFF)		7.5	pF typ	
C_D , C_S (ON)		12	pF typ	
POWER REQUIREMENTS				
I_{DD}	0.001	1	μA max μA typ	$V_{DD} = 5.5\text{ V}$ Digital inputs = 0 V or V_{DD}

¹ Temperature range for B version is -40°C to $+85^\circ\text{C}$.

² Guaranteed by design, not subject to production test.

$V_{DD} = 3\text{ V} \pm 10\%$, $GND = 0\text{ V}$, all specifications T_{MIN} to T_{MAX} , unless otherwise noted.¹

Table 2.

Parameter	B Version		Unit	Test Conditions/Comments
	25°C	T_{MIN} to T_{MAX}		
ANALOG SWITCH				
Analogue Signal Range		0 to 1.5	V	
On Resistance, R_{ON}	4		Ω typ	$V_D = 0\text{ V}$ to 1 V ; $I_S = -10\text{ mA}$
	6	7	Ω max	
On Resistance Match Between Channels, ΔR_{ON}	0.15		Ω typ	$V_D = 0\text{ V}$ to 1 V ; $I_S = -10\text{ mA}$
		0.5	Ω max	
On Resistance Flatness, $R_{FLAT(ON)}$	1.5		Ω typ	$V_D = 0\text{ V}$ to 1 V ; $I_S = -10\text{ mA}$
		3	Ω max	
LEAKAGE CURRENTS				
Source Off Leakage, I_S (OFF)	± 0.001		nA typ	$V_D = 2\text{ V}/1\text{ V}$, $V_S = 1\text{ V}/2\text{ V}$, see Figure 17
	± 0.1	± 0.25	nA max	
Drain Off Leakage, I_D (OFF)	± 0.001		nA typ	$V_D = 2\text{ V}/1\text{ V}$, $V_S = 1\text{ V}/2\text{ V}$, see Figure 17
	± 0.1	± 0.25	nA max	
Channel On Leakage, I_D , I_S (ON)	± 0.001		nA typ	$V_D = V_S = 2\text{ V}/1\text{ V}$, see Figure 18
	± 0.1	± 0.25	nA max	
DIGITAL INPUTS				
Input High Voltage, V_{INH}		2.0	V min	
Input Low Voltage, V_{INL}		0.4	V max	
Input Current				
I_{INL} or I_{INH}	0.001		μA typ	$V_{IN} = V_{INL}$ or V_{INH}
		± 0.1	μA max	
Digital Input Capacitance, C_{IN}		3	pF typ	
DYNAMIC CHARACTERISTICS²				
t_{ON} , $t_{ON}(\overline{EN})$		7	ns typ	$C_L = 35\text{ pF}$, $R_L = 50\ \Omega$, $V_S = 1.5\text{ V}$, see Figure 22
		14	ns max	
t_{OFF} , $t_{OFF}(\overline{EN})$		4	ns typ	$C_L = 35\text{ pF}$, $R_L = 50\ \Omega$, $V_S = 1.5\text{ V}$, see Figure 22
		8	ns max	
Break-Before-Make Time Delay, t_D		3	ns typ	$C_L = 35\text{ pF}$, $R_L = 50\ \Omega$, $V_{S1} = V_{S2} = 1.5\text{ V}$, see Figure 23
		1	ns min	
Off Isolation		-65	dB typ	$f = 10\text{ MHz}$, $R_L = 50\ \Omega$
Channel-to-Channel Crosstalk		-70	dB typ	$f = 10\text{ MHz}$, $R_L = 50\ \Omega$, see Figure 21
Bandwidth -3 dB		400	MHz typ	$R_L = 50\ \Omega$, see Figure 19
Distortion		1.5	% typ	$R_L = 100\ \Omega$
Charge Injection		4	pC typ	$C_L = 1\text{ nF}$, see Figure 24, $V_S = 0\text{ V}$
C_S (OFF)		5	pF typ	
C_D (OFF)		7.5	pF typ	
C_D , C_S (ON)		12	pF typ	
POWER REQUIREMENTS				
I_{DD}		1	μA max	$V_{DD} = 3.3\text{ V}$
	0.001		μA typ	Digital inputs = 0 V or V_{DD}

¹ Temperature range for B version is -40°C to $+85^\circ\text{C}$.

² Guaranteed by design, not subject to production test.

ABSOLUTE MAXIMUM RATINGS

T_A = 25°C, unless otherwise noted.

Table 3.

Parameters	Rating
V _{DD} to GND	−0.3 V to +6 V
Analog, Digital Inputs ¹	−0.3 V to V _{DD} + 0.3 V or 30 mA, whichever occurs first
Continuous Current, S or D	100 mA
Peak Current, S or D	300 mA (pulsed at 1 ms, 10% duty cycle max)
Operating Temperature Range	
Industrial (B Version)	−40°C to +85°C
Storage Temperature Range	−65°C to +150°C
Junction Temperature	150°C
Thermal Impedance, θ _{JA}	
16-Lead QSSOP	105.44°C/W ²
16-Lead LFCSP (3 mm × 3 mm)	48.7°C/W ²
Lead Temperature Soldering	
Vapor Phase (60 sec)	215°C
Infrared (15 sec)	220°C
Reflow Soldering (Pb-free)	
Peak Temperature	260°C (+0°C/−5°C)
Time at Peak Temperature	10 sec to 40 sec

¹ Overvoltages at IN, S, or D are clamped by internal diodes. Current should be limited to the maximum ratings given.

² Measured with the device soldered on a four-layer board.

Stresses at or above those listed under Absolute Maximum Ratings may cause permanent damage to the product. This is a stress rating only; functional operation of the product at these or any other conditions above those indicated in the operational section of this specification is not implied. Operation beyond the maximum operating conditions for extended periods may affect product reliability.

ESD CAUTION



ESD (electrostatic discharge) sensitive device. Charged devices and circuit boards can discharge without detection. Although this product features patented or proprietary protection circuitry, damage may occur on devices subjected to high energy ESD. Therefore, proper ESD precautions should be taken to avoid performance degradation or loss of functionality.

PIN CONFIGURATIONS AND FUNCTION DESCRIPTIONS

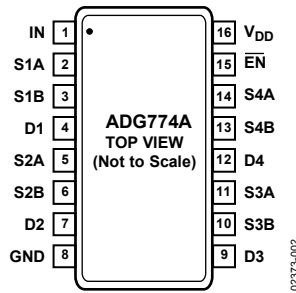
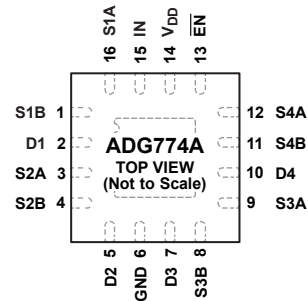

Figure 2. QSOP Pin Configuration



NOTES
1. THE EXPOSED PAD MUST BE TIED TO GND.

Figure 3. LFCSP Pin Configuration

Table 4. Pin Function Descriptions

Pin No.		Mnemonic	Function
QSOP	LFCSP		
1	15	IN	Logic Control Input.
2	16	S1A	Source Terminal 1A. May be an input or output.
3	1	S1B	Source Terminal 1B. May be an input or output.
4	2	D1	Drain Terminal D1. May be an input or output.
5	3	S2A	Source Terminal 2A. May be an input or output.
6	4	S2B	Source Terminal 2B. May be an input or output.
7	5	D2	Drain Terminal D2. May be an input or output.
8	6	GND	Ground (0 V) Reference.
9	7	D3	Drain Terminal D3. May be an input or output.
10	8	S3B	Source Terminal 3B. May be an input or output.
11	9	S3A	Source Terminal 3A. May be an input or output.
12	10	D4	Drain Terminal D4. May be an input or output.
13	11	S4B	Source Terminal 4B. May be an input or output.
14	12	S4A	Source Terminal 4A. May be an input or output.
15	13	\overline{EN}	Logic Control Input. When high, all switches are disabled.
16	14	V _{DD}	Most Positive Power Supply Potential.
Not applicable	17	EPAD	Exposed Pad. The exposed pad must be tied to GND.

Table 5. Truth Table

\overline{EN}	IN	D1	D2	D3	D4	Function
1	X	Hi-Z	Hi-Z	Hi-Z	Hi-Z	DISABLE
0	0	S1A	S2A	S3A	S4A	IN = 0
0	1	S1B	S2B	S3B	S4B	IN = 1

TYPICAL PERFORMANCE CHARACTERISTICS

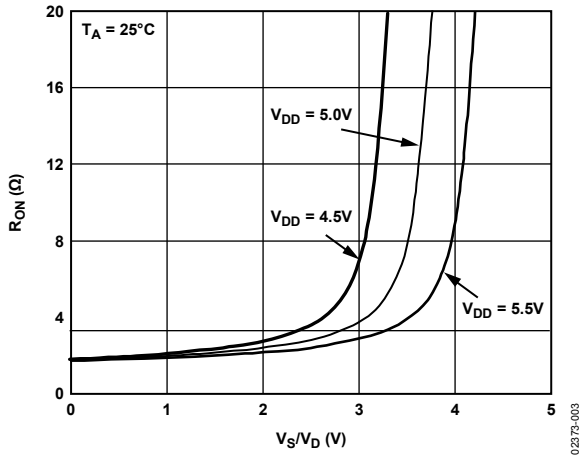

Figure 4. On Resistance as a Function of Drain (V_D) or Source (V_S) Voltage for $V_{DD} = 5\text{ V} \pm 10\%$

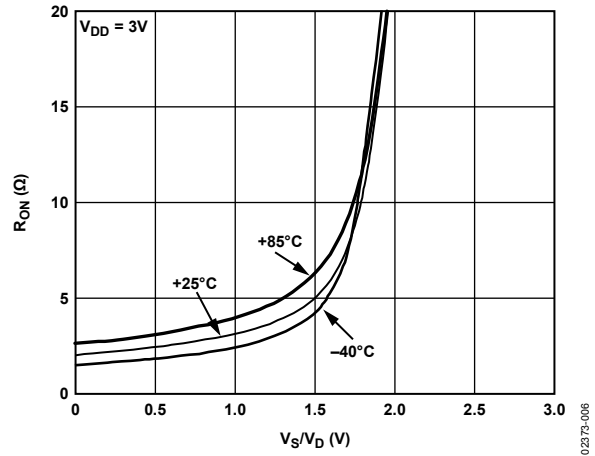

Figure 7. On Resistance as a Function of Drain (V_D) or Source (V_S) Voltage for Different Temperatures with 3V Single Supplies

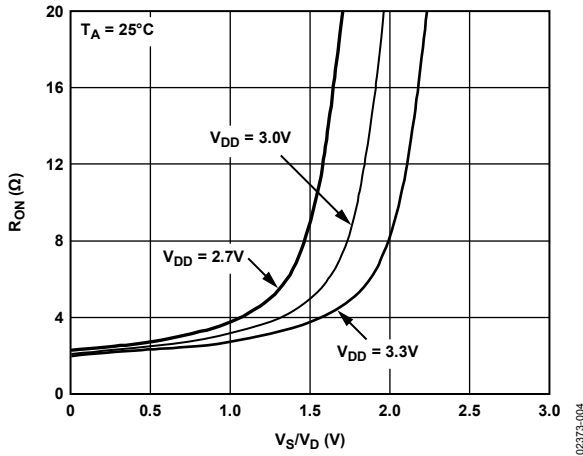

Figure 5. On Resistance as a Function of Drain (V_D) or Source (V_S) Voltage for $V_{DD} = 3\text{ V} \pm 10\%$

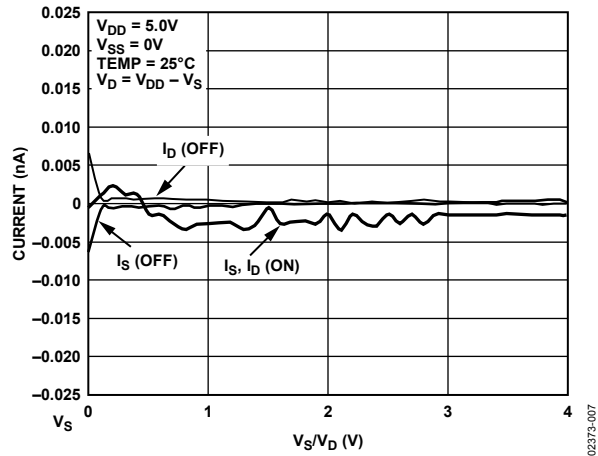

Figure 8. Leakage Current as a Function of Drain (V_D) or Source (V_S) Voltage for $V_{DD} = 5\text{ V}$

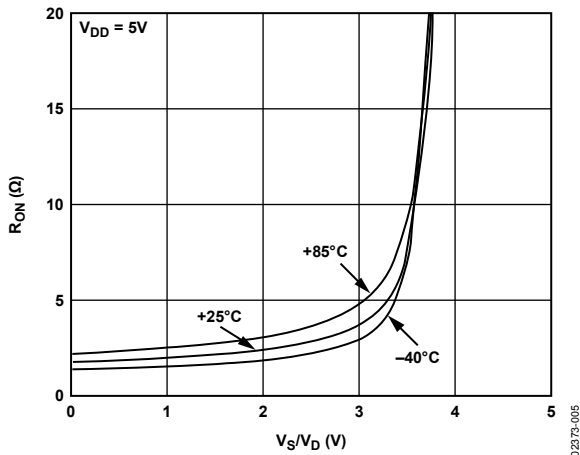

Figure 6. On Resistance as a Function of Drain (V_D) or Source (V_S) Voltage for Different Temperatures with 5V Single Supplies

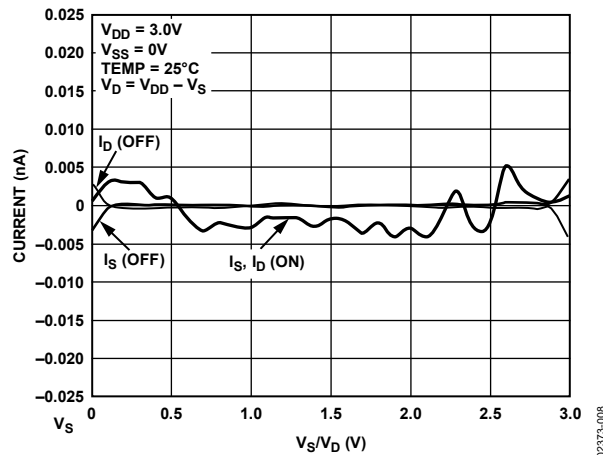

Figure 9. Leakage Current as a Function of Drain (V_D) or Source (V_S) Voltage for $V_{DD} = 3\text{ V}$

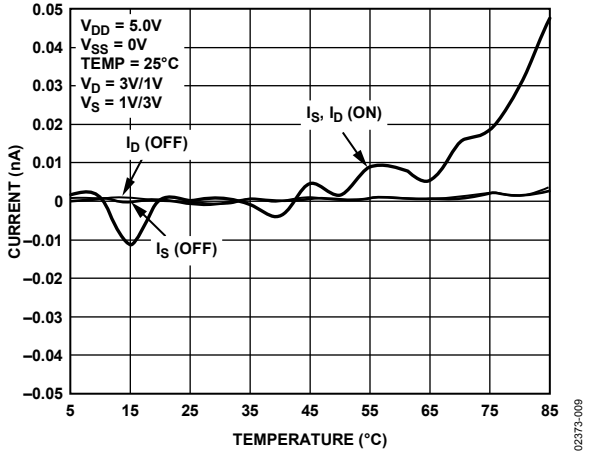

Figure 10. Leakage Current as a Function of Temperature, $V_{DD} = 5V$

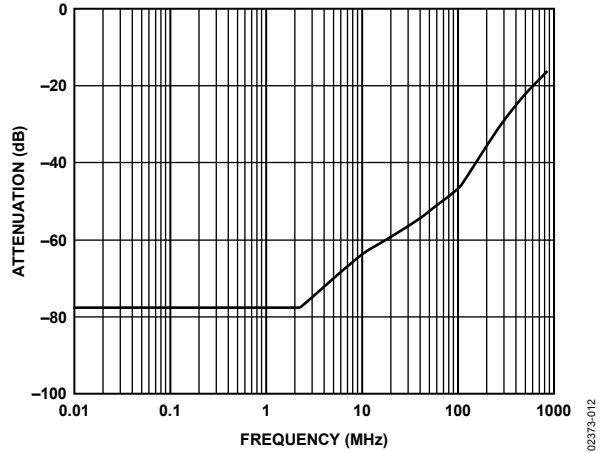

Figure 13. Crosstalk vs. Frequency

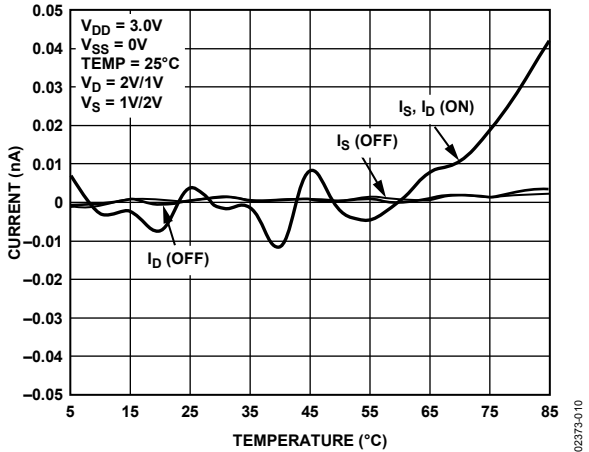

Figure 11. Leakage Current as a Function of Temperature, $V_{DD} = 3V$

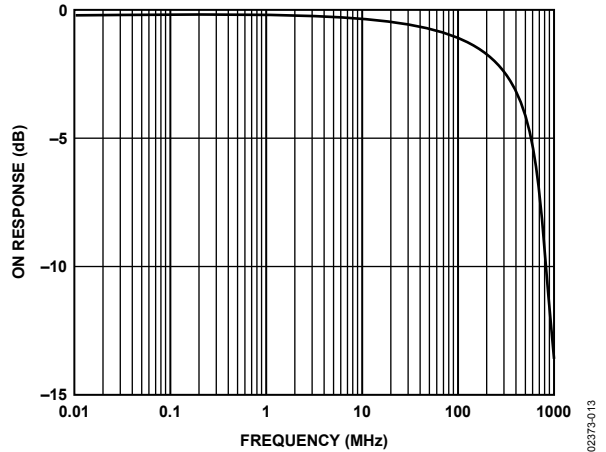

Figure 14. Bandwidth

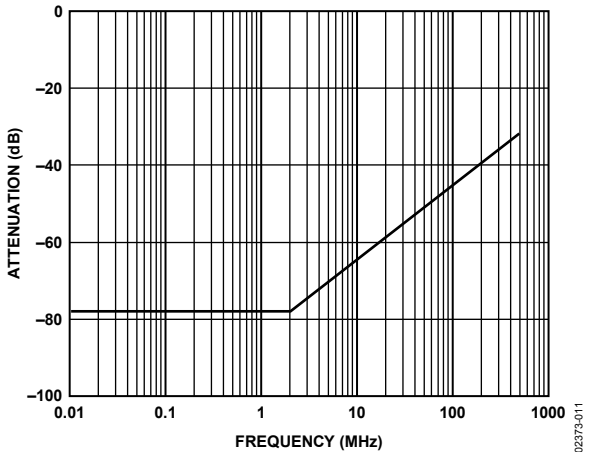

Figure 12. Off Isolation vs. Frequency

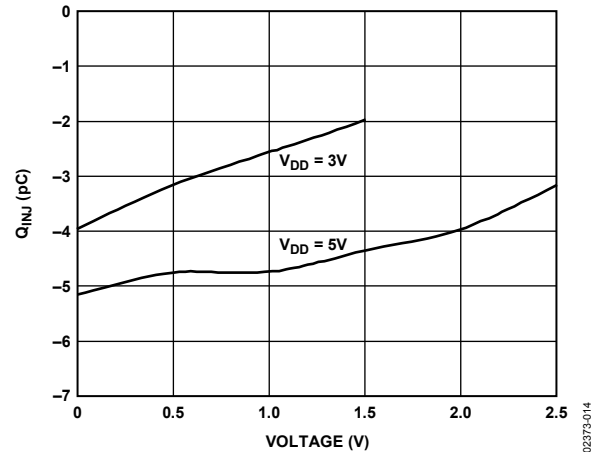

Figure 15. Charge Injection vs. Source Voltage

TEST CIRCUITS

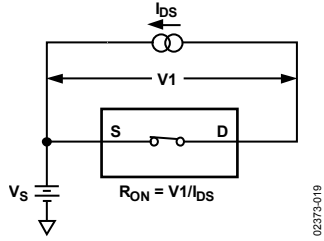

Figure 16. On Resistance

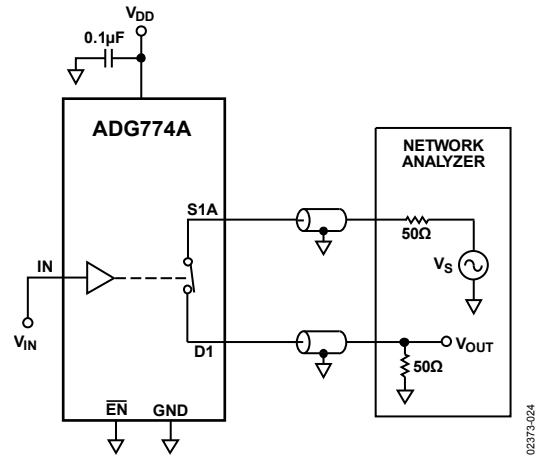

Figure 19. Bandwidth

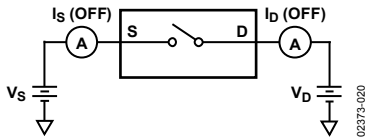

Figure 17. Off Leakage

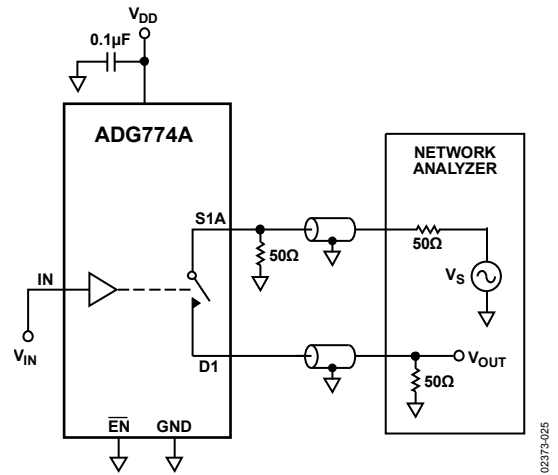

Figure 20. Off Isolation

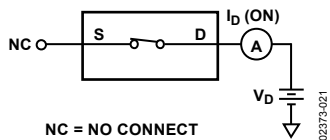

Figure 18. On Leakage

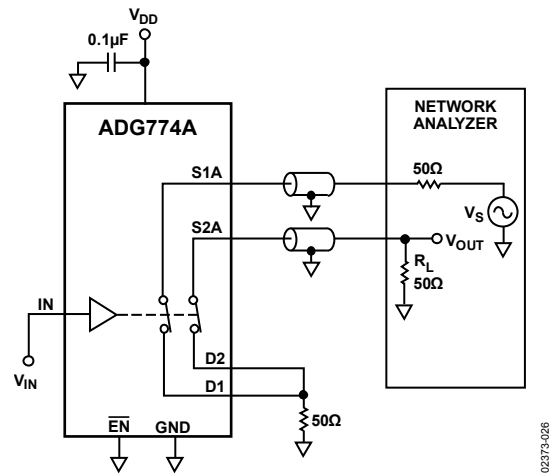

Figure 21. Channel-to-Channel Crosstalk

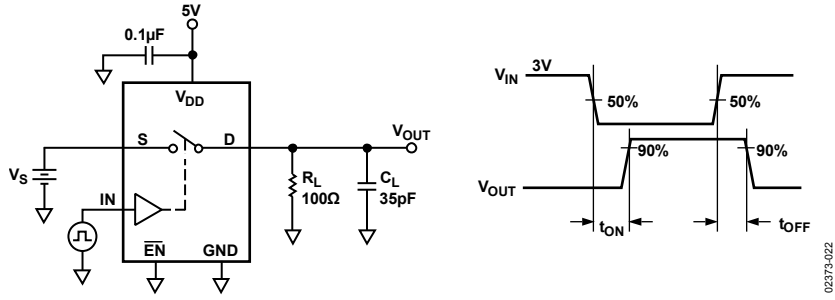

Figure 22. Switching Times

02373-022

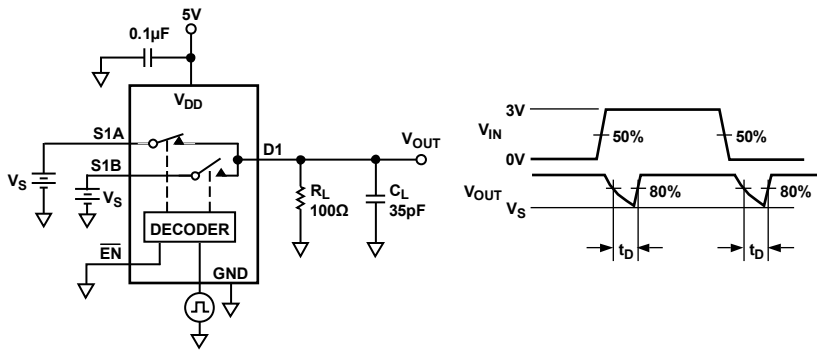

Figure 23. Break-Before-Make Time Delay

02373-023

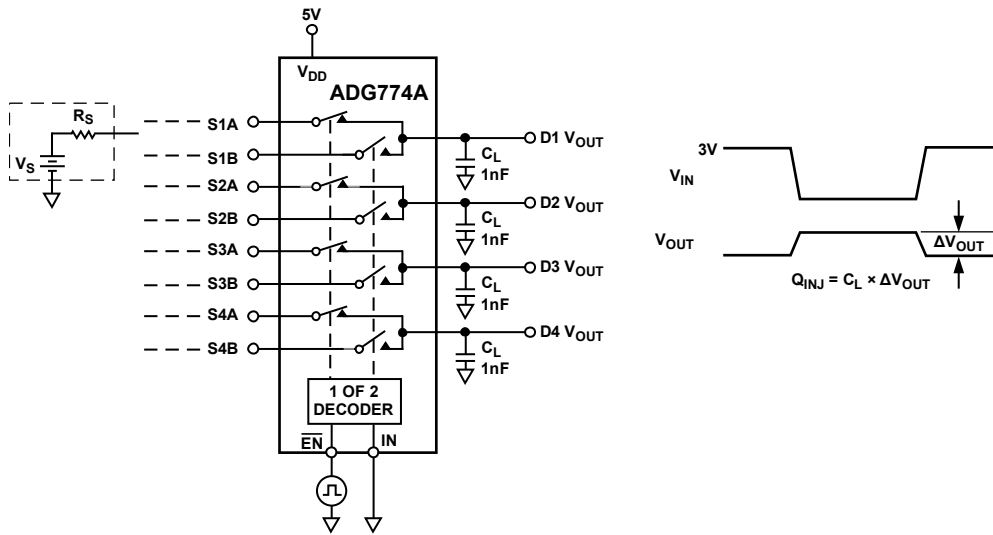

Figure 24. Charge Injection

02373-027

TERMINOLOGY

V_{DD}

Most positive power supply potential.

GND

Ground (0 V) reference.

S

Source terminal. May be an input or output.

D

Drain terminal. May be an input or output.

IN

Logic control input.

$\overline{\text{EN}}$

Logic control input.

R_{ON}

Ohmic resistance between D and S.

ΔR_{ON}

On resistance match between any two channels, that is, $R_{ON \text{ max}} - R_{ON \text{ min}}$.

R_{FLAT(ON)}

Flatness is defined as the difference between the maximum and minimum value of on resistance as measured over the specified analog signal range.

I_S (OFF)

Source leakage current with the switch off.

I_D (OFF)

Drain leakage current with the switch off.

I_D, I_S (ON)

Channel leakage current with the switch on.

V_D (V_S)

Analog voltage on the D and S terminals.

C_S (OFF)

Off switch source capacitance.

C_D (OFF)

Off switch drain capacitance.

C_D, C_S (ON)

On switch capacitance.

t_{ON}

Delay between applying the digital control input and the output switching on. See Figure 22.

t_{OFF}

Delay between applying the digital control input and the output switching off.

t_D

Off time or on time measured between the 80% points of both switches when switching from one address state to another. See Figure 23.

Crosstalk

A measure of unwanted signal that is coupled through from one channel to another because of parasitic capacitance.

Off Isolation

A measure of unwanted signal coupling through an off switch.

Bandwidth

Frequency response of the switch in the on state measured at 3 dB down.

Distortion

$R_{FLAT(ON)}/R_L$

APPLICATION CIRCUITS

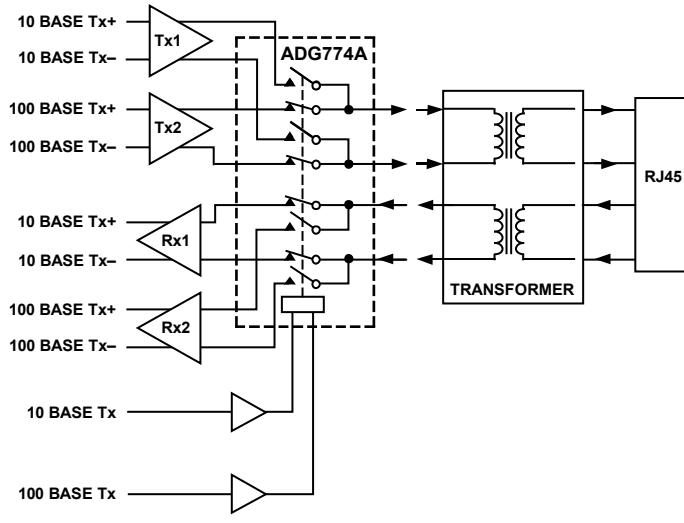

Figure 25. Full Duplex Transceiver

02373-016

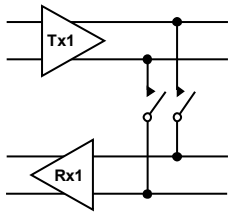

Figure 26. Loop Back

02373-016

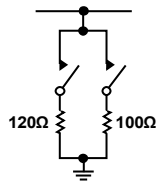

Figure 27. Line Termination

02373-017

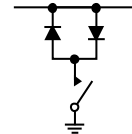
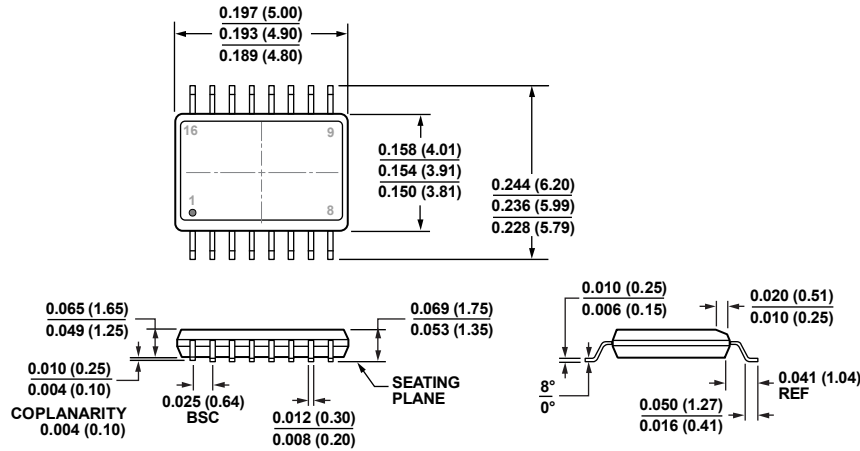

Figure 28. Line Clamp

02373-018

OUTLINE DIMENSIONS



COMPLIANT TO JEDEC STANDARDS MO-137-AB
 CONTROLLING DIMENSIONS ARE IN INCHES; MILLIMETER DIMENSIONS
 (IN PARENTHESES) ARE ROUNDED-OFF INCH EQUIVALENTS FOR
 REFERENCE ONLY AND ARE NOT APPROPRIATE FOR USE IN DESIGN.

Figure 29. 16-Lead Shrink Small Outline Package [QSOP]
 (RQ-16)

Dimensions shown in inches and (millimeters)

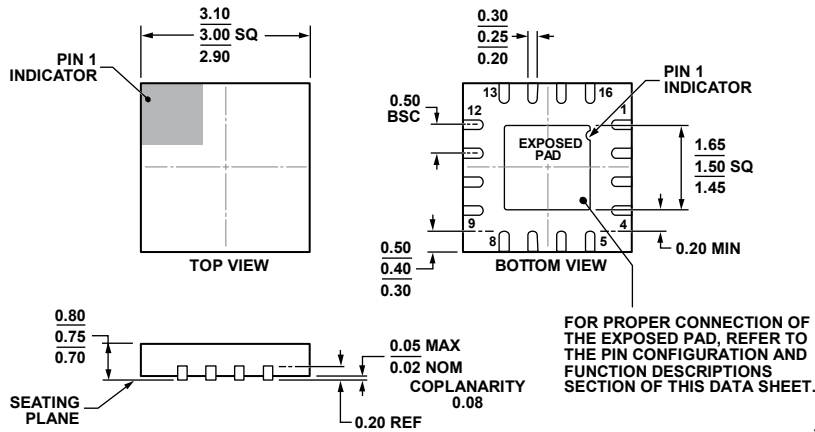

COMPLIANT TO JEDEC STANDARDS MO-220-WEED-6.

Figure 30. 16-Lead Lead Frame Chip Scale Package [LFCSP]
 3 mm x 3 mm Body and 0.75 mm Package Height
 (CP-16-27)

Dimensions shown in millimeters

ORDERING GUIDE

Model ¹	Temperature Range	Package Description	Package Option
ADG774ABRQ-REEL7	-40°C to +85°C	16-Lead Shrink Small Outline Package [QSOP]	RQ-16
ADG774ABRQZ	-40°C to +85°C	16-Lead Shrink Small Outline Package [QSOP]	RQ-16
ADG774ABRQZ-REEL	-40°C to +85°C	16-Lead Shrink Small Outline Package [QSOP]	RQ-16
ADG774ABRQZ-REEL7	-40°C to +85°C	16-Lead Shrink Small Outline Package [QSOP]	RQ-16
ADG774ABCPZ-REEL	-40°C to +85°C	16-Lead Lead Frame Chip Scale Package [LFCSP]	CP-16-27
ADG774ABCPZ-R2	-40°C to +85°C	16-Lead Lead Frame Chip Scale Package [LFCSP]	CP-16-27

¹ Z = RoHS Compliant Part.

NOTES

Looking for pricing, stock, or lifecycle information?

Click below to explore more details on WIN SOURCE:

 [View ADG774ABRQZ on WIN SOURCE](#)

 [Analog Devices Inc. Information](#)

Optimize Your Supply Chain with WIN SOURCE Solutions

-  Global Sourcing Solution
-  Obsolete Management
-  Cost Control Management
-  Shortage Management
-  Alternative Solution
-  Excess Inventory Management