



**THE DATASHEET OF  
ADG658YRQZ**



## FEATURES

- ±2 V to ±6 V dual supply
- 2 V to 12 V single supply
- Automotive temperature range  $-40^{\circ}\text{C}$  to  $+125^{\circ}\text{C}$
- <0.1 nA leakage currents
- 45  $\Omega$  on resistance over full signal range
- Rail-to-rail switching operation
- Single 8-to-1 multiplexer **ADG658**
- Differential 4-to-1 multiplexer **ADG659**
- 16-lead LFCSP/TSSOP/QSOP packages
- Typical power consumption <0.1  $\mu\text{W}$
- TTL/CMOS compatible inputs
- Package upgrades to 74HC4051/74HC4052 and  
MAX4051/MAX4052/MAX4581/MAX4582

## APPLICATIONS

- Automotive applications
- Automatic test equipment
- Data acquisition systems
- Battery-powered systems
- Communication systems
- Audio and video signal routing
- Relay replacement
- Sample-and-hold systems
- Industrial control systems

## GENERAL DESCRIPTION

The **ADG658** and **ADG659** are low voltage, CMOS analog multiplexers comprised of eight single channels and four differential channels, respectively. The **ADG658** switches one of eight inputs (S1–S8) to a common output, D, as determined by the 3-bit binary address lines A0, A1, and A2. The **ADG659** switches one of four differential inputs to a common differential output, as determined by the 2-bit binary address lines A0 and A1. An  $\overline{\text{EN}}$  input on both devices enables or disables the device. When disabled, all channels are switched off.

These devices are designed on an enhanced process that provides lower power dissipation yet gives high switching speeds. These devices can operate equally well as either multiplexers or demultiplexers and have an input range that extends to the supplies. All channels exhibit break-before-make switching action, preventing momentary shorting when switching channels. All digital inputs have 0.8 V to 2.4 V logic thresholds, ensuring TTL/CMOS logic compatibility when using single +5 V or dual  $\pm 5$  V supplies.

## FUNCTIONAL BLOCK DIAGRAM

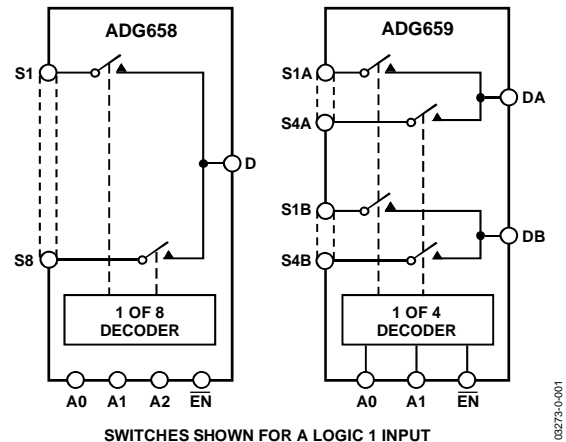

Figure 1.

The **ADG658** and **ADG659** are available in 16-lead TSSOP/QSOP packages and 16-lead 4 mm × 4 mm LFCSP packages.

## PRODUCT HIGHLIGHTS

1. Single- and dual-supply operation. The **ADG658** and **ADG659** offer high performance and are fully specified and guaranteed with  $\pm 5$  V, +5 V, and +3 V supply rails.
2. Automotive temperature range  $-40^{\circ}\text{C}$  to  $+125^{\circ}\text{C}$ .
3. Low power consumption, typically <0.1  $\mu\text{W}$ .
4. 16-lead 4 mm × 4 mm LFCSP packages, 16-lead TSSOP package and 16-lead QSOP package.

Rev. D

[Document Feedback](#)

Information furnished by Analog Devices is believed to be accurate and reliable. However, no responsibility is assumed by Analog Devices for its use, nor for any infringements of patents or other rights of third parties that may result from its use. Specifications subject to change without notice. No license is granted by implication or otherwise under any patent or patent rights of Analog Devices. Trademarks and registered trademarks are the property of their respective owners.

## TABLE OF CONTENTS

Features .....	1	Absolute Maximum Ratings .....	9
Applications.....	1	ESD Caution.....	9
Functional Block Diagram .....	1	Pin Configurations and Function Descriptions .....	11
General Description .....	1	Typical Performance Characteristics .....	12
Product Highlights .....	1	Terminology .....	15
Revision History .....	2	Test Circuits.....	16
Specifications.....	3	Outline Dimensions .....	19
Dual Supply .....	3	Ordering Guide .....	20
5 V Single Supply.....	5	Automotive Products.....	20
2.7 V to 3.6 V Single Supply.....	7		

## REVISION HISTORY

### 11/2016—Rev. C to Rev. D

Changes to Figure 3 and Table 7.....	11
Updated Outline Dimensions .....	19
Changes to Ordering Guide .....	20

### 9/2014—Rev. B to Rev. C

Moved Terminology Section.....	15
Updated Outline Dimensions .....	19
Changes to Ordering Guide .....	20

### 2/2009—Rev. A to Rev. B

Changes to Ordering Guide .....	20
---------------------------------	----

### 7/2004—Rev. 0 to Rev. A

Updated Format.....	Universal
Added QSOP Package Outline .....	20
Changes to Ordering Guide .....	20
3/03—Rev. 0: Initial Version	

## SPECIFICATIONS

## DUAL SUPPLY

$V_{DD} = +5\text{ V} \pm 10\%$ ,  $V_{SS} = -5\text{ V} \pm 10\%$ ,  $GND = 0\text{ V}$ , unless otherwise noted.

Table 1.

Parameter	B Version			Y Version		Unit	Test Conditions/Comments
	+25°C	-40°C to +85°C	-40°C to +125°C	-40°C to +125°C			
ANALOG SWITCH							
Analog Signal Range				$V_{SS}$ to $V_{DD}$	V	$V_{DD} = +4.5\text{ V}$ , $V_{SS} = -4.5\text{ V}$	
On Resistance ( $R_{ON}$ )	45				$\Omega$ typ	$V_S = \pm 4.5\text{ V}$ , $I_S = 1\text{ mA}$ ; see Figure 21	
	75	90		100	$\Omega$ max		
On Resistance Match between Channels ( $\Delta R_{ON}$ )	1.3				$\Omega$ typ	$V_S = 3.5\text{ V}$ , $I_S = 1\text{ mA}$	
	3	3.2		3.5	$\Omega$ max	$V_{DD} = +5\text{ V}$ , $V_{SS} = -5\text{ V}$ ;	
On Resistance Flatness ( $R_{FLAT(ON)}$ )	10				$\Omega$ typ	$V_S = \pm 3\text{ V}$ , $I_S = 1\text{ mA}$	
	16	17		18	$\Omega$ max		
LEAKAGE CURRENTS							
Source OFF Leakage $I_S$ (OFF)	$\pm 0.005$				nA typ	$V_{DD} = +5.5\text{ V}$ , $V_{SS} = -5.5\text{ V}$	
	$\pm 0.2$			$\pm 5$	nA max	$V_D = \pm 4.5\text{ V}$ , $V_S = \mp 4.5\text{ V}$ ; see Figure 22	
Drain OFF Leakage $I_D$ (OFF)	$\pm 0.005$				nA typ	$V_D = \pm 4.5\text{ V}$ , $V_S = \mp 4.5\text{ V}$ ; see Figure 23	
ADG658	$\pm 0.2$			$\pm 5$	nA max		
ADG659	$\pm 0.1$			$\pm 2.5$	nA max		
Channel ON Leakage $I_D$ , $I_S$ (ON)	$\pm 0.005$				nA typ	$V_D = V_S = \pm 4.5\text{ V}$ ; see Figure 24	
ADG658	$\pm 0.2$			$\pm 5$	nA max		
ADG659	$\pm 0.1$			$\pm 2.5$	nA max		
DIGITAL INPUTS							
Input High Voltage, $V_{INH}$				2.4	V min		
Input Low Voltage, $V_{INL}$				0.8	V max		
Input Current							
$I_{INL}$ or $I_{INH}$	0.005				$\mu\text{A}$ typ	$V_{IN} = V_{INL}$ or $V_{INH}$	
				$\pm 1$	$\mu\text{A}$ max		
$C_{IN}$ , Digital Input Capacitance	2				pF typ		
DYNAMIC CHARACTERISTICS <sup>1</sup>							
$t_{TRANSITION}$	80				ns typ	$R_L = 300\ \Omega$ , $C_L = 35\text{ pF}$	
	115	140		165	ns max	$V_S = 3\text{ V}$ ; see Figure 25	
$t_{ON}(\overline{EN})$	80				ns typ	$R_L = 300\ \Omega$ , $C_L = 35\text{ pF}$	
	115	140		165	ns max	$V_S = 3\text{ V}$ ; see Figure 27	
$t_{OFF}(\overline{EN})$	30				ns typ	$R_L = 300\ \Omega$ , $C_L = 35\text{ pF}$	
	45	50		55	ns max	$V_S = 3\text{ V}$ ; see Figure 27	
Break-Before-Make Time Delay, $t_{BBM}$	50				ns typ	$R_L = 300\ \Omega$ , $C_L = 35\text{ pF}$	
				10	ns min	$V_{S1} = V_{S2} = 3\text{ V}$ ; see Figure 26	
Charge Injection	2				pC typ	$V_S = 0\text{ V}$ , $R_S = 0\ \Omega$ ,	
	4				pC max	$C_L = 1\text{ nF}$ ; see Figure 28	
Off Isolation	-90				dB typ	$R_L = 50\ \Omega$ , $C_L = 5\text{ pF}$ , $f = 1\text{ MHz}$ ; see Figure 29	
Total Harmonic Distortion, THD + N	0.025				% typ	$R_L = 600\ \Omega$ , $2\text{ V p-p}$ , $f = 20\text{ Hz to } 20\text{ kHz}$	
Channel-to-Channel Crosstalk (ADG659)	-90				dB typ	$R_L = 50\ \Omega$ , $C_L = 5\text{ pF}$ , $f = 1\text{ MHz}$ ; see Figure 31	
-3 dB Bandwidth							
ADG658	210				MHz typ	$R_L = 50\ \Omega$ , $C_L = 5\text{ pF}$ ; see Figure 30	
ADG659	400				MHz typ		

Parameter	+25°C	B Version	Y Version	Unit	Test Conditions/Comments
		–40°C to +85°C	–40°C to +125°C		
C <sub>S</sub> (OFF)	4			pF typ	f = 1 MHz
C <sub>D</sub> (OFF)					
ADG658	23			pF typ	f = 1 MHz
ADG659	12			pF typ	f = 1 MHz
C <sub>D</sub> , C <sub>S</sub> (ON)					
ADG658	28			pF typ	f = 1 MHz
ADG659	16			pF typ	f = 1 MHz
POWER REQUIREMENTS					
I <sub>DD</sub>	0.01			μA typ	V <sub>DD</sub> = +5.5 V, V <sub>SS</sub> = –5.5 V Digital Inputs = 0 V or 5.5 V
			1	μA max	
I <sub>SS</sub>	0.01			μA typ	Digital Inputs = 0 V or 5.5 V
			1	μA max	

<sup>1</sup> Guaranteed by design; not subject to production test.

**5 V SINGLE SUPPLY**

$V_{DD} = 5\text{ V} \pm 10\%$ ,  $V_{SS} = 0\text{ V}$ ,  $GND = 0\text{ V}$ , unless otherwise noted.

**Table 2.**

Parameter	B Version			Y Version		Unit	Test Conditions/Comments
	+25°C	-40°C to +85°C	-40°C to +125°C	-40°C to +125°C	-40°C to +125°C		
<b>ANALOG SWITCH</b>							
Analog Signal Range				0 to $V_{DD}$		V	$V_{DD} = 4.5\text{ V}$ , $V_{SS} = 0\text{ V}$
On Resistance ( $R_{ON}$ )	85					$\Omega$ typ	$V_S = 0\text{ V to } 4.5\text{ V}$ , $I_S = 1\text{ mA}$ ; see Figure 21
	150	160	200			$\Omega$ max	
On Resistance Match between Channels ( $\Delta R_{ON}$ )	4.5					$\Omega$ typ	$V_S = 3.5\text{ V}$ , $I_S = 1\text{ mA}$
	8	9	10			$\Omega$ max	
On Resistance Flatness ( $R_{FLAT(ON)}$ )	13	14	16			$\Omega$ typ	$V_{DD} = 5\text{ V}$ , $V_{SS} = 0\text{ V}$ , $V_S = 1.5\text{ V to } 4\text{ V}$ , $I_S = 1\text{ mA}$
<b>LEAKAGE CURRENTS</b>							
Source OFF Leakage $I_S$ (OFF)	$\pm 0.005$					nA typ	$V_{DD} = 5.5\text{ V}$ $V_S = 1\text{ V/}4.5\text{ V}$ , $V_D = 4.5\text{ V/}1\text{ V}$ ; see Figure 22
	$\pm 0.2$			$\pm 5$		nA max	
Drain OFF Leakage $I_D$ (OFF)	$\pm 0.005$					nA typ	$V_S = 1\text{ V/}4.5\text{ V}$ , $V_D = 4.5\text{ V/}1\text{ V}$ ; see Figure 23
ADG658	$\pm 0.2$			$\pm 5$		nA max	
ADG659	$\pm 0.1$			$\pm 2.5$		nA max	
Channel ON Leakage $I_D$ , $I_S$ (ON)	$\pm 0.005$					nA typ	$V_S = V_D = 1\text{ V or } 4.5\text{ V}$ , see Figure 24
ADG658	$\pm 0.2$			$\pm 5$		nA max	
ADG659	$\pm 0.1$			$\pm 2.5$		nA max	
<b>DIGITAL INPUTS</b>							
Input High Voltage, $V_{INH}$				2.4		V min	
Input Low Voltage, $V_{INL}$				0.8		V max	
Input Current							
$I_{INL}$ or $I_{INH}$	0.005					$\mu\text{A}$ typ	$V_{IN} = V_{INL}$ or $V_{INH}$
				$\pm 1$		$\mu\text{A}$ max	
$C_{IN}$ , Digital Input Capacitance	2					pF typ	
<b>DYNAMIC CHARACTERISTICS<sup>1</sup></b>							
$t_{TRANSITION}$	120					ns typ	$R_L = 300\ \Omega$ , $C_L = 35\text{ pF}$
	200	270	300			ns max	$V_S = 3\text{ V}$ ; see Figure 25
$t_{ON}(\overline{EN})$	120					ns typ	$R_L = 300\ \Omega$ , $C_L = 35\text{ pF}$
	190	245	280			ns max	$V_S = 3\text{ V}$ ; see Figure 27
$t_{OFF}(\overline{EN})$	35					ns typ	$R_L = 300\ \Omega$ , $C_L = 35\text{ pF}$
	50	60	70			ns max	$V_S = 3\text{ V}$ ; see Figure 27
Break-Before-Make Time Delay, $t_{BBM}$	100					ns typ	$R_L = 300\ \Omega$ , $C_L = 35\text{ pF}$
				10		ns min	$V_{S1} = V_{S2} = 3\text{ V}$ ; see Figure 26
Charge Injection	0.5					pC typ	$V_S = 2.5\text{ V}$ , $R_S = 0\ \Omega$ , $C_L = 1\text{ nF}$ ; see Figure 28
	1					pC max	
Off Isolation	-90					dB typ	$R_L = 50\ \Omega$ , $C_L = 5\text{ pF}$ , $f = 1\text{ MHz}$ ; see Figure 29
Channel-to-Channel Crosstalk	-90					dB typ	$R_L = 50\ \Omega$ , $C_L = 5\text{ pF}$ ; $f = 1\text{ MHz}$ ; see Figure 31
(ADG659)							
-3 dB Bandwidth							
ADG658	180					MHz typ	$R_L = 50\ \Omega$ , $C_L = 5\text{ pF}$ ; see Figure 30
ADG659	330					MHz typ	
$C_S$ (OFF)	5					pF typ	$f = 1\text{ MHz}$
$C_D$ (OFF)							
ADG658	29					pF typ	$f = 1\text{ MHz}$
ADG659	15					pF typ	$f = 1\text{ MHz}$

Parameter	B Version		Y Version	Unit	Test Conditions/Comments
	+25°C	-40°C to +85°C	-40°C to +125°C		
C <sub>D</sub> , C <sub>S</sub> (ON)					
ADG658	30			pF typ	f = 1 MHz
ADG659	16			pF typ	f = 1 MHz
POWER REQUIREMENTS					V <sub>DD</sub> = 5.5 V
I <sub>DD</sub>	0.01		1	μA typ μA max	Digital Inputs = 0 V or 5.5 V

<sup>1</sup> Guaranteed by design; not subject to production test.

**2.7 V TO 3.6 V SINGLE SUPPLY**

$V_{DD} = 2.7$  to  $3.6$  V,  $V_{SS} = 0$  V,  $GND = 0$  V, unless otherwise noted.

**Table 3.**

Parameter	B Version			Y Version	Unit	Test Conditions/Comments
	+25°C	-40°C to +85°C	-40°C to +125°C	-40°C to +125°C		
<b>ANALOG SWITCH</b>						
Analog Signal Range				0 to $V_{DD}$	V	$V_{DD} = 2.7$ V, $V_{SS} = 0$ V
On Resistance ( $R_{ON}$ )	185				$\Omega$ typ	$V_S = 0$ V to $2.7$ V, $I_S = 0.1$ mA; see Figure 21
	300	350	400		$\Omega$ max	
On Resistance Match between Channels ( $\Delta R_{ON}$ )	2				$\Omega$ typ	$V_S = 1.5$ V, $I_S = 0.1$ mA
	4.5	6	7		$\Omega$ max	
<b>LEAKAGE CURRENTS</b>						
Source OFF Leakage $I_S$ (OFF)	$\pm 0.005$				nA typ	$V_{DD} = 3.3$ V
	$\pm 0.2$			$\pm 5$	nA max	$V_S = 1$ V/3 V, $V_D = 3$ V/1 V; see Figure 22
Drain OFF Leakage $I_D$ (OFF)	$\pm 0.005$				nA typ	$V_S = 1$ V/3 V, $V_D = 3$ V/1 V; see Figure 23
ADG658	$\pm 0.2$			$\pm 5$	nA max	
ADG659	$\pm 0.1$			$\pm 2.5$	nA max	
Channel ON Leakage $I_D, I_S$ (ON)	$\pm 0.005$				nA typ	$V_S = V_D = 1$ V or $3$ V, see Figure 24
ADG658	$\pm 0.2$			$\pm 5$	nA max	
ADG659	$\pm 0.1$			$\pm 2.5$	nA max	
<b>DIGITAL INPUTS</b>						
Input High Voltage, $V_{INH}$				2.0	V min	
Input Low Voltage, $V_{INL}$				0.5	V max	
Input Current						
$I_{INL}$ or $I_{INH}$	0.005				$\mu$ A typ	$V_{IN} = V_{INL}$ or $V_{INH}$
				$\pm 1$	$\mu$ A max	
$C_{IN}$ , Digital Input Capacitance	2				pF typ	
<b>DYNAMIC CHARACTERISTICS<sup>1</sup></b>						
$t_{TRANSITION}$	200				ns typ	$R_L = 300$ $\Omega$ , $C_L = 35$ pF
	370	440	490		ns max	$V_S = 1.5$ V; see Figure 25
$t_{ON}(\overline{EN})$	230				ns typ	$R_L = 300$ $\Omega$ , $C_L = 35$ pF
	370	440	490		ns max	$V_S = 1.5$ V; see Figure 27
$t_{OFF}(\overline{EN})$	50				ns typ	$R_L = 300$ $\Omega$ , $C_L = 35$ pF
	80	90	110		ns max	$V_S = 1.5$ V; see Figure 27
Break-Before-Make Time Delay, $t_{BBM}$	200				ns typ	$R_L = 300$ $\Omega$ , $C_L = 35$ pF
				10	ns min	$V_{S1} = V_{S2} = 1.5$ V; see Figure 26
Charge Injection	1				pC typ	$V_S = 1.5$ V, $R_S = 0$ $\Omega$ , $C_L = 1$ nF; see Figure 28
	2				pC max	
Off Isolation	-90				dB typ	$R_L = 50$ $\Omega$ , $C_L = 5$ pF, $f = 1$ MHz; see Figure 29
Channel-to-Channel Crosstalk (ADG659)	-90				dB typ	$R_L = 50$ $\Omega$ , $C_L = 5$ pF; $f = 1$ MHz; see Figure 31
-3 dB Bandwidth						
ADG658	160				MHz typ	$R_L = 50$ $\Omega$ , $C_L = 5$ pF; see Figure 30
ADG659	300				MHz typ	
$C_S$ (OFF)	5				pF typ	$f = 1$ MHz
$C_D$ (OFF)						
ADG658	29				pF typ	$f = 1$ MHz
ADG659	15				pF typ	$f = 1$ MHz

Parameter	B Version		Y Version	Unit	Test Conditions/Comments
	+25°C	-40°C to +85°C	-40°C to +125°C		
C <sub>D</sub> , C <sub>S</sub> (ON)					
ADG658	30			pF typ	f = 1 MHz
ADG659	16			pF typ	f = 1 MHz
POWER REQUIREMENTS					V <sub>DD</sub> = 3.6 V
I <sub>DD</sub>	0.01		1	μA typ μA max	Digital Inputs = 0 V or 3.6 V

<sup>1</sup> Guaranteed by design; not subject to production test.

## ABSOLUTE MAXIMUM RATINGS

$T_A = 25^\circ\text{C}$ , unless otherwise noted.

**Table 4.**

Parameter	Rating
$V_{DD}$ to $V_{SS}$	13 V
$V_{DD}$ to GND	-0.3 V to +13 V
$V_{SS}$ to GND	+0.3 V to -6.5 V
Analog Inputs <sup>1</sup>	$V_{SS} - 0.3\text{ V}$ to $V_{DD} + 0.3\text{ V}$
Digital Inputs <sup>1</sup>	GND - 0.3 V to $V_{DD} + 0.3\text{ V}$ or 10 mA, whichever occurs first
Peak Current, S or D (Pulsed at 1 ms, 10% duty cycle max)	40 mA
Continuous Current, S or D	20 mA
Operating Temperature Range	
Automotive (Y Version)	-40°C to +125°C
Industrial (B Version)	-40°C to +85°C
Storage Temperature Range	-65°C to +150°C
Junction Temperature	150°C
$\theta_{JA}$ Thermal Impedance	
16-Lead QSOP	104°C/W
16-Lead TSSOP	150.4°C/W
16-Lead LFCSP (4-Layer Board)	70°C/W
Lead Temperature, Soldering	
Vapor Phase (60 sec)	215°C
Infrared (15 sec)	220°C
ESD	5.5 kV

<sup>1</sup> Over voltages at  $A_x$ ,  $\overline{EN}$ , S, or D are clamped by internal diodes. Current must be limited to the maximum ratings.

Stresses above those listed under Absolute Maximum Ratings may cause permanent damage to the device. This is a stress rating only; functional operation of the device at these or any other conditions above those indicated in the operational section of this specification is not implied. Exposure to absolute maximum rating conditions for extended periods may affect device reliability.

### ESD CAUTION



**ESD (electrostatic discharge) sensitive device.** Charged devices and circuit boards can discharge without detection. Although this product features patented or proprietary protection circuitry, damage may occur on devices subjected to high energy ESD. Therefore, proper ESD precautions should be taken to avoid performance degradation or loss of functionality.

**Table 5. ADG658 Truth Table**

<b>A2</b>	<b>A1</b>	<b>A0</b>	<b>EN</b>	<b>Switch Condition</b>
X <sup>1</sup>	X <sup>1</sup>	X <sup>1</sup>	1	None
0	0	0	0	1
0	0	1	0	2
0	1	0	0	3
0	1	1	0	4
1	0	0	0	5
1	0	1	0	6
1	1	0	0	7
1	1	1	0	8

<sup>1</sup>X = Don't Care

**Table 6. ADG659 Truth Table**

<b>A1</b>	<b>A0</b>	<b>EN</b>	<b>On Switch Pair</b>
X <sup>1</sup>	X <sup>1</sup>	1	None
0	0	0	1
0	1	0	2
1	0	0	3
1	1	0	4

<sup>1</sup>X = Don't Care

## PIN CONFIGURATIONS AND FUNCTION DESCRIPTIONS

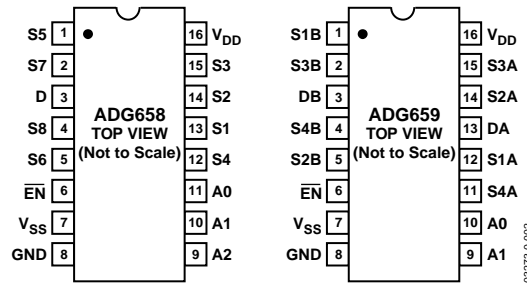
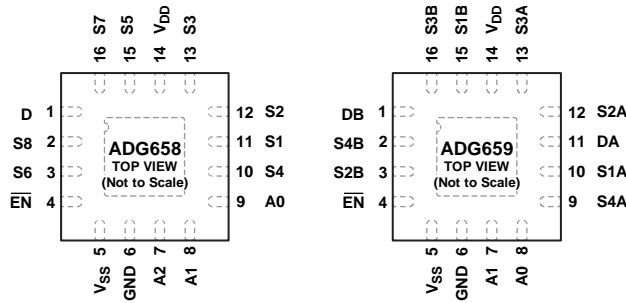

Figure 2. 16-Lead TSSOP/QSOP Pin Configuration



NOTES  
1. EXPOSED PAD. THE EXPOSED PAD MUST BE LEFT FLOATING.

Figure 3. 16-Lead, 4 mm × 4 mm LFCSP Pin Configuration

Table 7. Pin Function Descriptions

Parameter	Description
V <sub>DD</sub>	Most Positive Power Supply Potential.
V <sub>SS</sub>	Most Negative Power Supply Potential.
I <sub>DD</sub>	Positive Supply Current.
I <sub>SS</sub>	Negative Supply Current.
GND	Ground (0 V) Reference.
S	Source Terminal. Can be an input or output.
D	Drain Terminal. Can be an input or output.
A <sub>x</sub>	Logic Control Input.
EN	Active Low Digital Input. When high, device is disabled and all switches are OFF. When low, A <sub>x</sub> logic inputs determine ON switch.
EPAD (LFCSP Only)	Exposed Pad. The exposed pad must be left floating.

TYPICAL PERFORMANCE CHARACTERISTICS

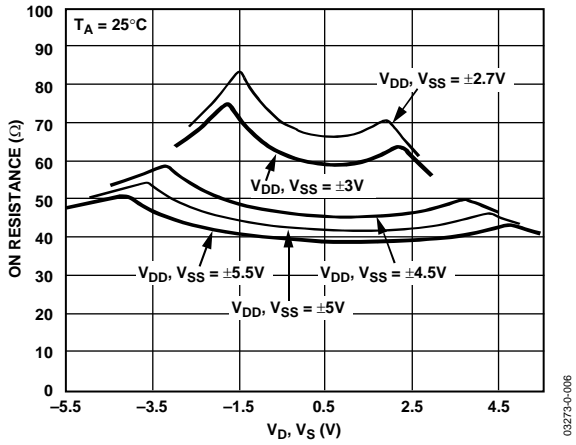

Figure 4. On Resistance vs.  $V_D$  ( $V_S$ ) for Dual Supply

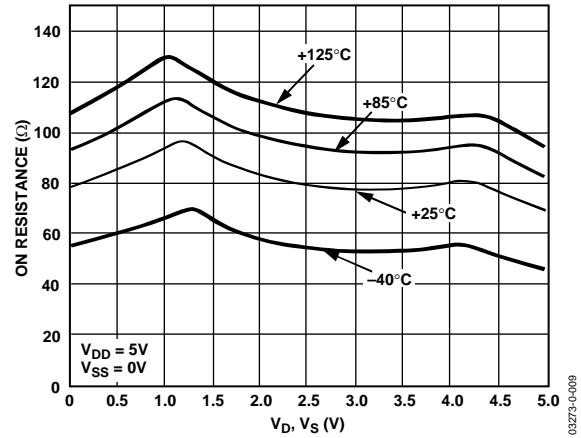

Figure 7. On Resistance vs.  $V_D$  ( $V_S$ ) for Different Temperatures (Single Supply)

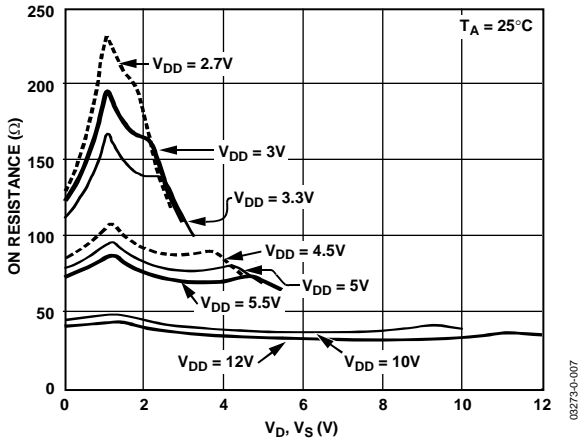

Figure 5. On Resistance vs.  $V_D$  ( $V_S$ ) for Single Supply

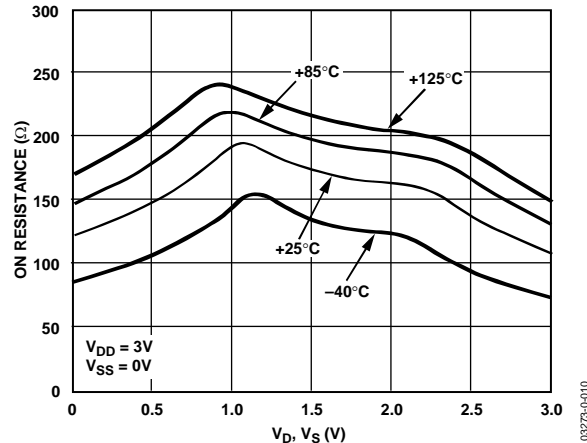

Figure 8. On Resistance vs.  $V_D$  ( $V_S$ ) for Different Temperatures (Single Supply)

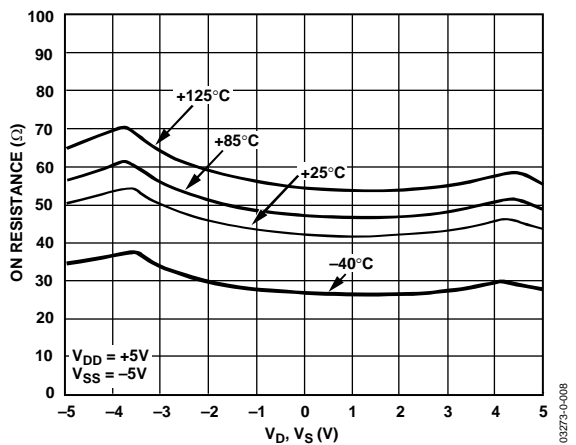

Figure 6. On Resistance vs.  $V_D$  ( $V_S$ ) for Different Temperatures (Dual Supply)

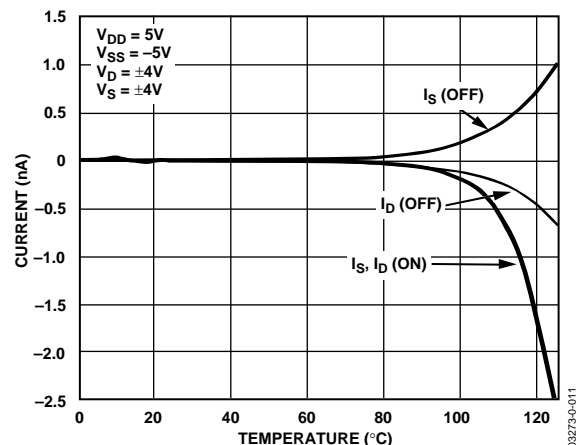

Figure 9. Leakage Current vs. Temperature (Dual Supply)

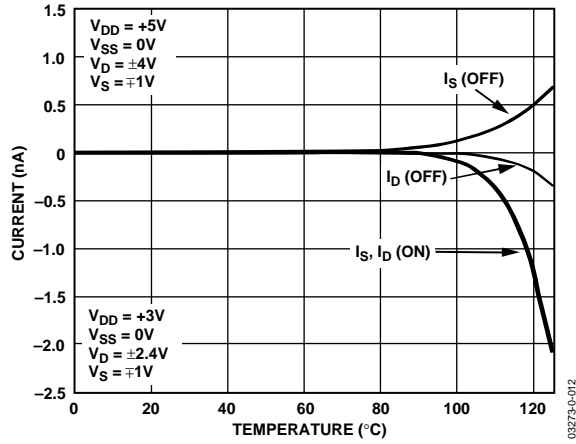

Figure 10. Leakage Current vs. Temperature (Single Supply)

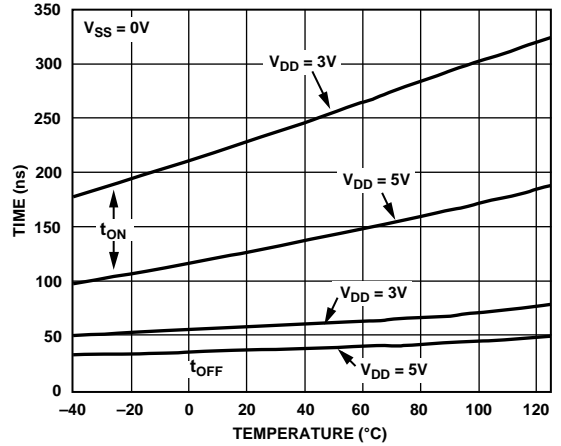

Figure 13.  $t_{ON}/t_{OFF}$  Times vs. Temperature (Single Supply)

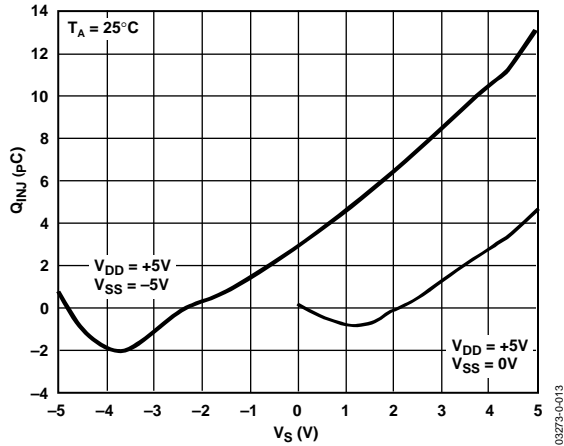

Figure 11. Charge Injection vs. Source Voltage

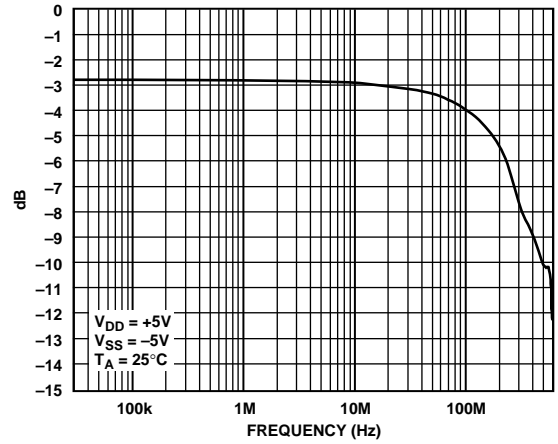

Figure 14. ON Response vs. Frequency (ADG658)

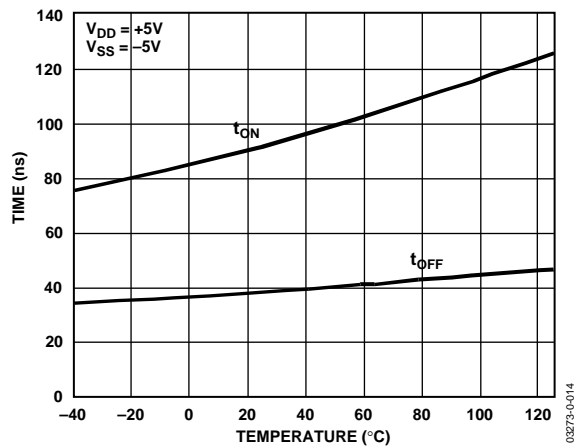

Figure 12.  $t_{ON}/t_{OFF}$  Times vs. Temperature (Dual Supply)

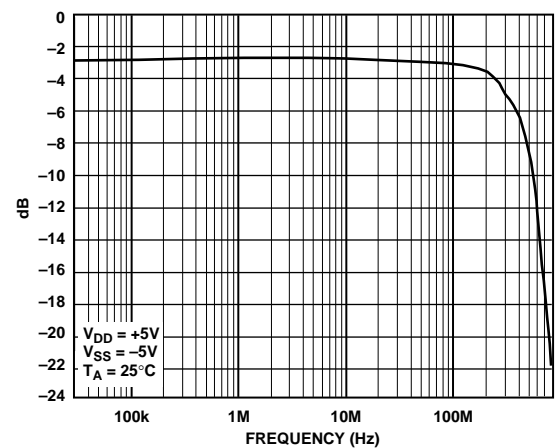

Figure 15. ON Response vs. Frequency (ADG659)

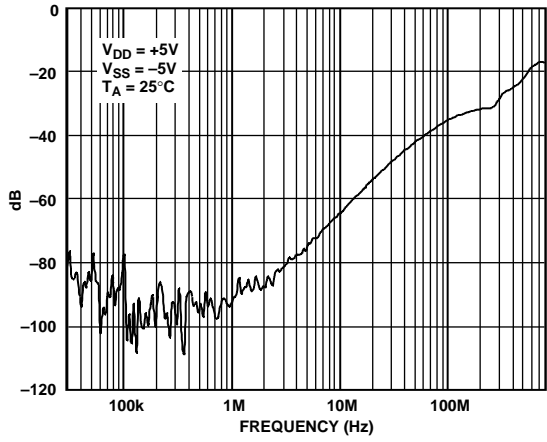

Figure 16. OFF Isolation vs. Frequency

03273-0-018

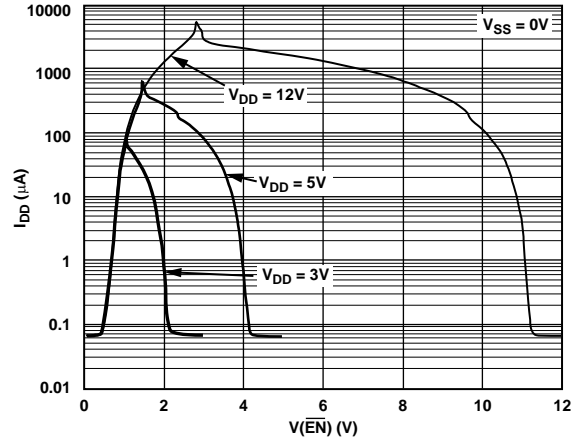

Figure 19.  $V_{DD}$  Current vs. Logic Level

03273-0-021

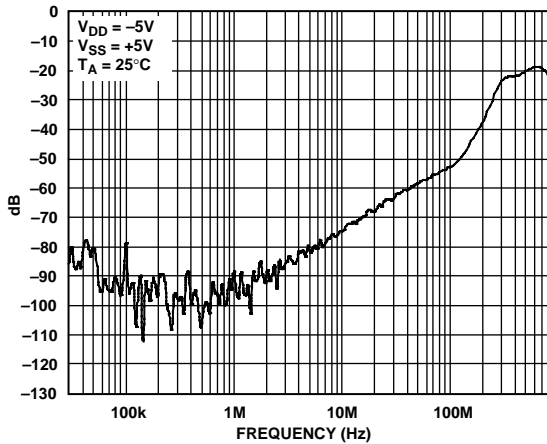

Figure 17. Crosstalk vs. Frequency

03273-0-019

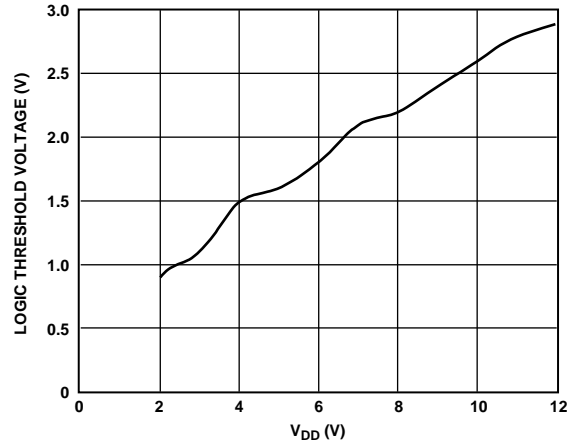

Figure 20. Logic Threshold Voltage vs. Supply Voltage

03273-0-022

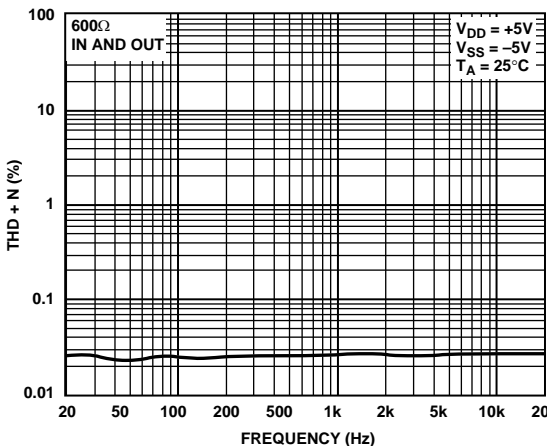

Figure 18. THD + Noise

03273-0-020

## TERMINOLOGY

**V<sub>D</sub> (V<sub>S</sub>)**

Analog Voltage on Terminals D, S.

**R<sub>ON</sub>**

Ohmic Resistance between D and S.

**ΔR<sub>ON</sub>**

On Resistance Match between Any Two Channels, i.e., R<sub>ONmax</sub> – R<sub>ONmin</sub>.

**R<sub>FLAT(ON)</sub>**

Flatness is defined as the difference between the maximum and minimum value of ON Resistance as measured over the specified analog signal range.

**I<sub>S</sub> (OFF)**

Source Leakage Current with the Switch OFF.

**I<sub>D</sub> (OFF)**

Drain Leakage Current with the Switch OFF.

**I<sub>D</sub>, I<sub>S</sub> (ON)**

Channel Leakage Current with the Switch ON.

**V<sub>INL</sub>**

Maximum Input Voltage for Logic 0.

**V<sub>INH</sub>**

Minimum Input Voltage for Logic 1.

**I<sub>INL</sub> (I<sub>INH</sub>)**

Input Current of the Digital Input.

**C<sub>S</sub> (OFF)**

OFF Switch Source Capacitance. Measured with reference to ground.

**C<sub>D</sub> (OFF)**

OFF Switch Drain Capacitance. Measured with reference to ground.

**C<sub>D</sub>, C<sub>S</sub> (ON)**

ON Switch Capacitance. Measured with reference to ground.

**C<sub>IN</sub>**

Digital Input Capacitance.

**t<sub>ON</sub>**

Delay between Applying the Digital Control Input and the Output Switching ON. See Figure 27.

**t<sub>OFF</sub>**

Delay between Applying the Digital Control Input and the Output Switching OFF.

**t<sub>BEM</sub>**

ON Time. Measured between 80% points of both switches when switching from one address state to another.

**Charge Injection**

Measure of the Glitch Impulse Transferred from the Digital Input to the Analog Output during Switching.

**Off Isolation**

Measure of Unwanted Signal Coupling through an OFF Switch.

**Crosstalk**

Measure of Unwanted Signal Coupled through from One Channel to Another as a Result of Parasitic Capacitance.

**Bandwidth**

The Frequency at which the Output is Attenuated by 3 dB.

**On Response**

The Frequency Response of the ON Switch.

**Insertion Loss**

The Loss Due to the ON Resistance of the Switch.

TEST CIRCUITS

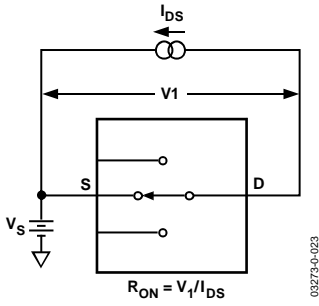

Figure 21. ON Resistance

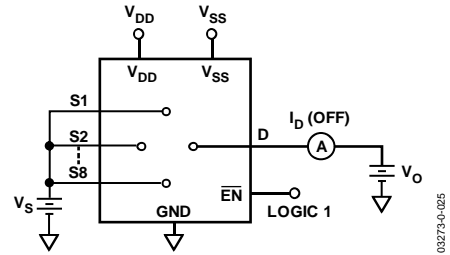

Figure 23. I<sub>D</sub> (OFF)

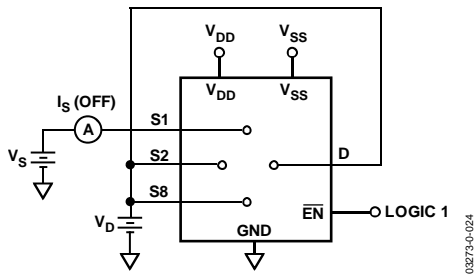

Figure 22. I<sub>S</sub> (OFF)

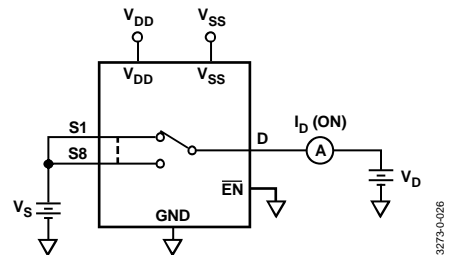
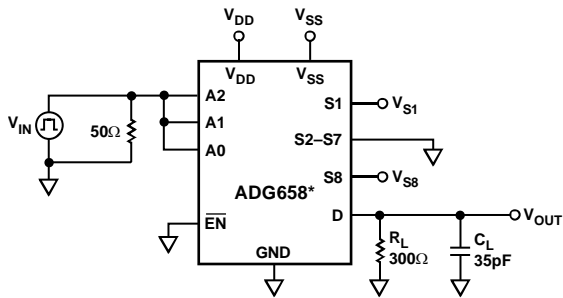

Figure 24. I<sub>D</sub> (ON)



\* SIMILAR CONNECTION FOR ADG659

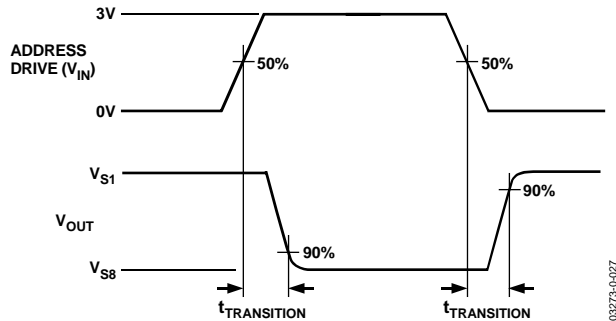
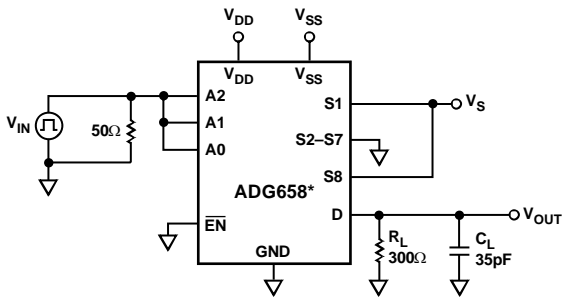

Figure 25. Switching Time of Multiplexer, t<sub>TRANSITION</sub>



\* SIMILAR CONNECTION FOR ADG659

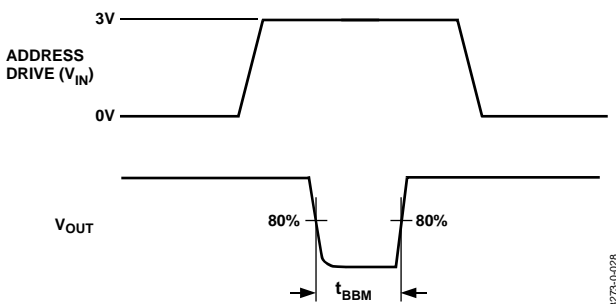

Figure 26. Break-Before-Make Delay, t<sub>BBM</sub>

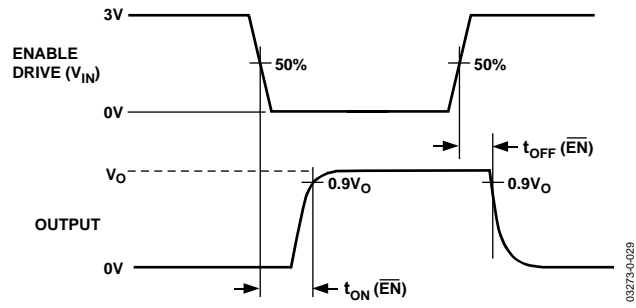
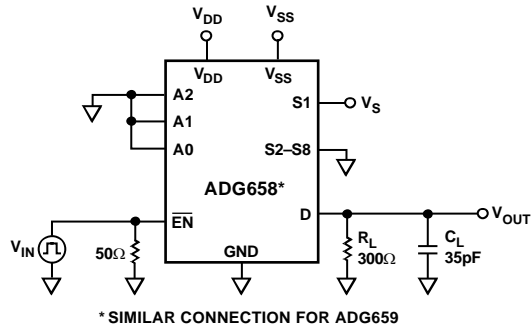

Figure 27. Enable Delay,  $t_{ON}(\overline{EN})$ ,  $t_{OFF}(\overline{EN})$

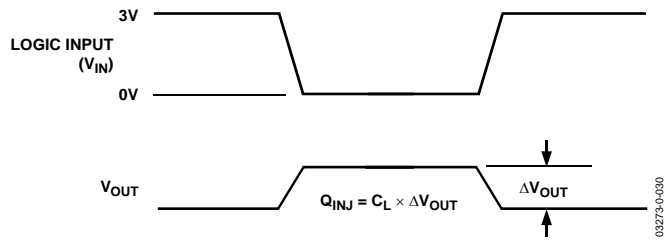
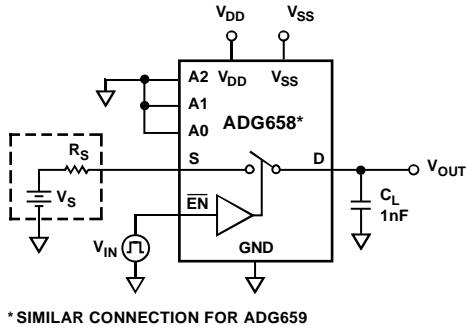

Figure 28. Charge Injection

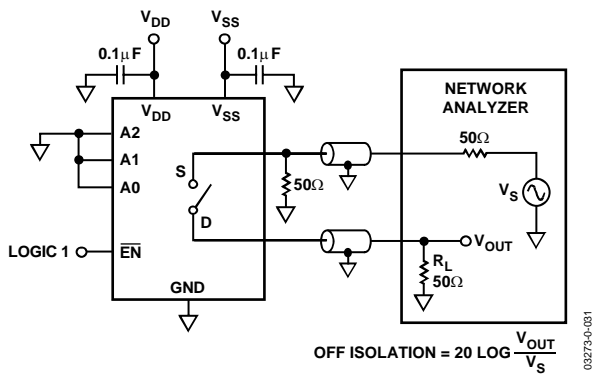

Figure 29. Off Isolation

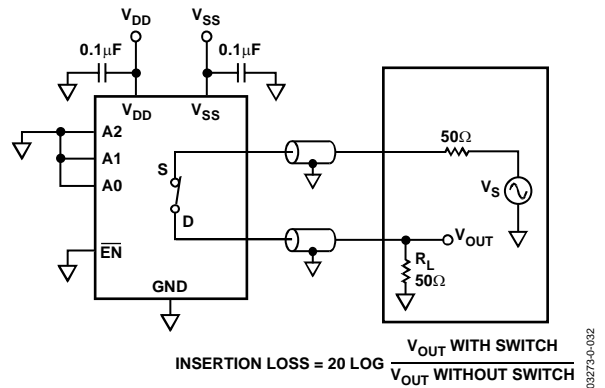
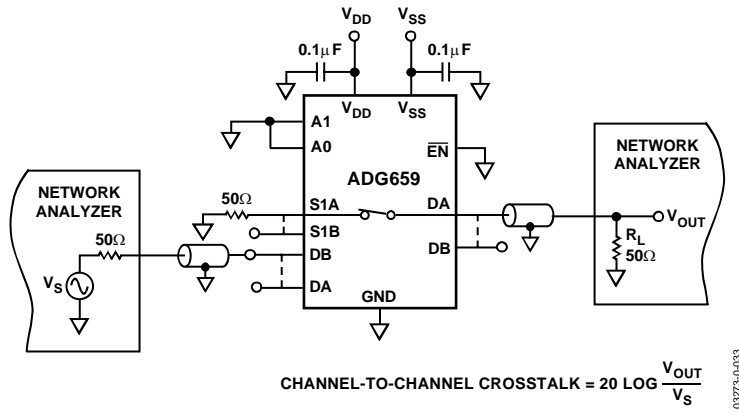

Figure 30. Bandwidth



03273-0-033

Figure 31. Channel-to-Channel Crosstalk

# OUTLINE DIMENSIONS

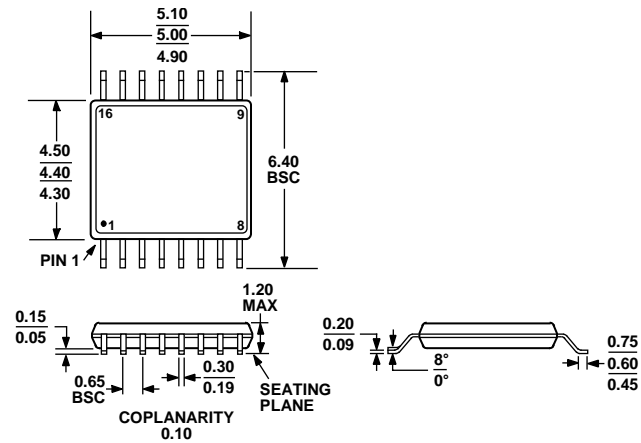

COMPLIANT TO JEDEC STANDARDS MO-153-AB

Figure 32. 16-Lead Thin Shrink Small Outline Package [TSSOP] (RU-16)

Dimensions shown in millimeters

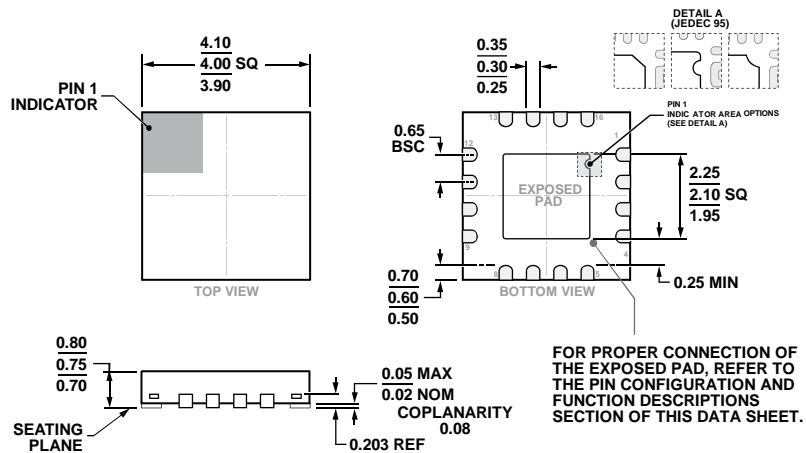

COMPLIANT TO JEDEC STANDARDS MO-220-WGGC.

Figure 33. 16-Lead Lead Frame Chip Scale Package [LFCSP] 4 mm x 4 mm Body and 0.75 mm Package Height (CP-16-23)

Dimensions shown in millimeters

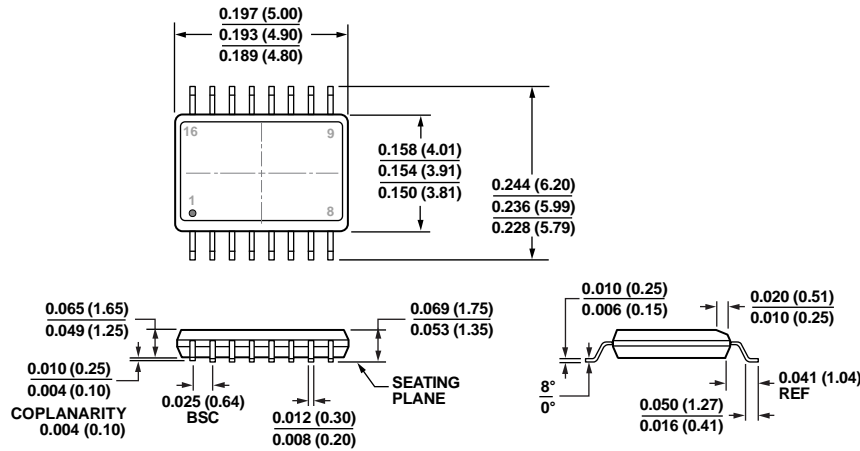

COMPLIANT TO JEDEC STANDARDS MO-137-AB  
 CONTROLLING DIMENSIONS ARE IN INCHES; MILLIMETER DIMENSIONS  
 (IN PARENTHESES) ARE ROUNDED-OFF INCH EQUIVALENTS FOR  
 REFERENCE ONLY AND ARE NOT APPROPRIATE FOR USE IN DESIGN.

Figure 34. 16-Lead Shrink Small Outline Package [QSOP]  
 (RQ-16)  
 Dimensions shown in inches and (millimeters)

09-12-2014-A

**ORDERING GUIDE**

Model <sup>1, 2</sup>	Temperature Range	Package Description	Package Option
ADG658YRU	-40°C to +125°C	16-Lead Thin Shrink Small Outline Package [TSSOP]	RU-16
ADG658YRU-REEL7	-40°C to +125°C	16-Lead Thin Shrink Small Outline Package [TSSOP]	RU-16
ADG658YRUZ	-40°C to +125°C	16-Lead Thin Shrink Small Outline Package [TSSOP]	RU-16
ADG658YRUZ-REEL7	-40°C to +125°C	16-Lead Thin Shrink Small Outline Package [TSSOP]	RU-16
ADG658YCPZ	-40°C to +85°C	16-Lead Lead Frame Chip Scale Package [LFCSP]	CP-16-23
ADG658YCPZ-REEL7	-40°C to +85°C	16-Lead Lead Frame Chip Scale Package [LFCSP]	CP-16-23
ADG658YRQ	-40°C to +125°C	16-Lead Shrink Small Outline Package [QSOP]	RQ-16
ADG658YRQZ	-40°C to +125°C	16-Lead Shrink Small Outline Package [QSOP]	RQ-16
ADG658YRQZ-REEL7	-40°C to +125°C	16-Lead Shrink Small Outline Package [QSOP]	RQ-16
ADW54003-0	-40°C to +125°C	16-Lead Thin Shrink Small Outline Package [TSSOP]	RU-16
ADW54003-0RL7	-40°C to +125°C	16-Lead Thin Shrink Small Outline Package [TSSOP]	RU-16
ADG659YRU	-40°C to +125°C	16-Lead Thin Shrink Small Outline Package [TSSOP]	RU-16
ADG659YRUZ	-40°C to +125°C	16-Lead Thin Shrink Small Outline Package [TSSOP]	RU-16
ADG659YRUZ-REEL7	-40°C to +125°C	16-Lead Thin Shrink Small Outline Package [TSSOP]	RU-16
ADG659YRUZ-REEL7	-40°C to +125°C	16-Lead Thin Shrink Small Outline Package [TSSOP]	RU-16
ADG659YCPZ	-40°C to +85°C	16-Lead Lead Frame Chip Scale Package [LFCSP]	CP-16-23
ADG659YCPZ-REEL7	-40°C to +85°C	16-Lead Lead Frame Chip Scale Package [LFCSP]	CP-16-23
ADG659YRQZ	-40°C to +125°C	16-Lead Shrink Small Outline Package [QSOP]	RQ-16

<sup>1</sup> Z = RoHS Compliant Part.  
<sup>2</sup> W = Qualified for Automotive Applications.

**AUTOMOTIVE PRODUCTS**

The ADW54003 models are available with controlled manufacturing to support the quality and reliability requirements of automotive applications. Note that these automotive models may have specifications that differ from the commercial models; therefore, designers should review the Specifications section of this data sheet carefully. Only the automotive grade products shown are available for use in automotive applications. Contact your local Analog Devices account representative for specific product ordering information and to obtain the specific Automotive Reliability reports for these models.

## Looking for pricing, stock, or lifecycle information?

Click below to explore more details on WIN SOURCE:

 [View ADG658YRQZ on WIN SOURCE](#)

 [Analog Devices Inc. Information](#)

## Optimize Your Supply Chain with WIN SOURCE Solutions

-  Global Sourcing Solution
-  Obsolete Management
-  Cost Control Management
-  Shortage Management
-  Alternative Solution
-  Excess Inventory Management