



**THE DATASHEET OF
ADG5404BRUZ-REEL7**



FEATURES

Latch-up proof
8 kV HBM ESD rating
Low on resistance (<10 Ω)
±9 V to ±22 V dual-supply operation
9 V to 40 V single-supply operation
48 V supply maximum ratings
Fully specified at ±15 V, ±20 V, +12 V, and +36 V
V_{SS} to V_{DD} analog signal range

APPLICATIONS

Relay replacement
Automatic test equipment
Data acquisition
Instrumentation
Avionics
Audio and video switching
Communication systems

GENERAL DESCRIPTION

The ADG5404 is a complementary metal-oxide semiconductor (CMOS) analog multiplexer, comprising four single channels.

The on-resistance profile is very flat over the full analog input range, ensuring excellent linearity and low distortion when switching audio signals.

The ADG5404 is designed on a trench process, which guards against latch-up. A dielectric trench separates the P and N channel transistors, thereby preventing latch-up even under severe overvoltage conditions.

The ADG5404 switches one of four inputs to a common output, D, as determined by the 3-bit binary address lines, A0, A1, and EN. Logic 0 on the EN pin disables the device. Each switch conducts equally well in both directions when on and has an input signal range that extends to the supplies. In the off condition, signal levels up to the supplies are blocked. All switches exhibit break-before-make switching action.

FUNCTIONAL BLOCK DIAGRAM

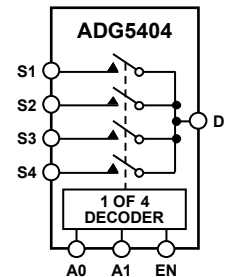

Figure 1.

PRODUCT HIGHLIGHTS

1. Trench Isolation Guards Against Latch-Up. A dielectric trench separates the P and N channel transistors, thereby preventing latch-up even under severe overvoltage conditions.
2. Low R_{ON}.
3. Dual-Supply Operation. For applications where the analog signal is bipolar, the ADG5404 can be operated from dual supplies of up to ±22 V.
4. Single-Supply Operation. For applications where the analog signal is unipolar, the ADG5404 can be operated from a single-rail power supply of up to 40 V.
5. 3 V logic-compatible digital inputs: V_{INH} = 2.0 V, V_{INL} = 0.8 V.
6. No V_I logic power supply required.

Rev. B

[Document Feedback](#)

Information furnished by Analog Devices is believed to be accurate and reliable. However, no responsibility is assumed by Analog Devices for its use, nor for any infringements of patents or other rights of third parties that may result from its use. Specifications subject to change without notice. No license is granted by implication or otherwise under any patent or patent rights of Analog Devices. Trademarks and registered trademarks are the property of their respective owners.

TABLE OF CONTENTS

Functional Block Diagram	1	ESD Caution.....	8
General Description	1	Pin Configurations and Function Descriptions	9
Revision History	2	Truth Table	9
Specifications.....	3	Typical Performance Characteristics	10
±15 V Dual Supply	3	Test Circuits.....	14
±20 V Dual Supply	4	Terminology	17
+12 V Single Supply	5	Trench Isolation.....	18
+36 V Single Supply	6	Applications Information	19
Continuous Current per Channel, S or D	7	Outline Dimensions	20
Absolute Maximum Ratings.....	8	Ordering Guide	20

REVISION HISTORY

11/2017—Rev. A to Rev. B

Changes to Table 1.....	3
Changes to Table 2.....	4
Changes to Table 3.....	5
Changes to Table 4.....	6
Changes to Figure 3.....	9
Updated Outline Dimensions	20
Change to Ordering Guide.....	20

7/2011—Rev. 0 to Rev. A

Changes to Product Highlights.....	1
Change to I_{SS} Parameter, Table 2.....	4
Updated Outline Dimensions	20

7/2010—Revision 0: Initial Version

SPECIFICATIONS

±15 V DUAL SUPPLY

$V_{DD} = 15\text{ V} \pm 10\%$, $V_{SS} = -15\text{ V} \pm 10\%$, GND = 0 V, unless otherwise noted.

Table 1.

Parameter	25°C	-40°C to +85°C	-40°C to +125°C	Unit	Test Conditions/Comments
ANALOG SWITCH					
Analog Signal Range			V_{DD} to V_{SS}	V	
On Resistance, R_{ON}	9.8			Ω typ	$V_S = \pm 10\text{ V}$, $I_S = -10\text{ mA}$; see Figure 23
	11	14	16	Ω max	$V_{DD} = +13.5\text{ V}$, $V_{SS} = -13.5\text{ V}$
On-Resistance Match Between Channels, ΔR_{ON}	0.35			Ω typ	$V_S = \pm 10\text{ V}$, $I_S = -10\text{ mA}$
	0.7	0.9	1.1	Ω max	
On-Resistance Flatness, $R_{FLAT(ON)}$	1.2			Ω typ	$V_S = \pm 10\text{ V}$, $I_S = -10\text{ mA}$
	1.6	2	2.2	Ω max	
LEAKAGE CURRENTS					
Source Off Leakage, I_S (Off)	± 0.05			nA typ	$V_{DD} = +16.5\text{ V}$, $V_{SS} = -16.5\text{ V}$
	± 0.25	± 0.75	± 6	nA max	$V_S = V_S = \pm 10\text{ V}$, $V_D = \mp 10\text{ V}$; see Figure 24
Drain Off Leakage, I_D (Off)	± 0.1			nA typ	$V_S = V_S = \pm 10\text{ V}$, $V_D = \mp 10\text{ V}$; see Figure 24
	± 0.4	± 2	± 16	nA max	
Channel On Leakage, I_D , I_S (On)	± 0.1			nA typ	$V_S = V_D = \pm 10\text{ V}$; see Figure 25
	± 0.4	± 2	± 16	nA max	
DIGITAL INPUTS					
Input High Voltage, V_{INH}			2.0	V min	
Input Low Voltage, V_{INL}			0.8	V max	
Input Current, I_{INL} or I_{INH}	0.002			μA typ	$V_{IN} = V_{GND}$ or V_{DD}
			± 0.1	μA max	
Digital Input Capacitance, C_{IN}	5			pF typ	
DYNAMIC CHARACTERISTICS¹					
Transition Time, $t_{TRANSITION}$	187			ns typ	$R_L = 300\ \Omega$, $C_L = 35\text{ pF}$
	242	285	330	ns max	$V_S = 10\text{ V}$; see Figure 30
t_{ON} (EN)	160			ns typ	$R_L = 300\ \Omega$, $C_L = 35\text{ pF}$
	204	247	278	ns max	$V_S = 10\text{ V}$; see Figure 32
t_{OFF} (EN)	125			ns typ	$R_L = 300\ \Omega$, $C_L = 35\text{ pF}$
	145	168	183	ns max	$V_S = 10\text{ V}$; see Figure 32
Break-Before-Make Time Delay, t_D	45			ns typ	$R_L = 300\ \Omega$, $C_L = 35\text{ pF}$
			12	ns min	$V_{S1} = V_{S2} = 10\text{ V}$; see Figure 31
Charge Injection, Q_{INJ}	220			pC typ	$V_S = 0\text{ V}$, $R_S = 0\ \Omega$, $C_L = 1\text{ nF}$; see Figure 33
Off Isolation	-78			dB typ	$R_L = 50\ \Omega$, $C_L = 5\text{ pF}$, $f = 100\text{ kHz}$; see Figure 26
Channel-to-Channel Crosstalk	-58			dB typ	$R_L = 50\ \Omega$, $C_L = 5\text{ pF}$, $f = 1\text{ MHz}$; see Figure 28
Total Harmonic Distortion + Noise	0.009			% typ	$R_L = 1\text{ k}\Omega$, 15 V p-p , $f = 20\text{ Hz}$ to 20 kHz ; see Figure 29
-3 dB Bandwidth	53			MHz typ	$R_L = 50\ \Omega$, $C_L = 5\text{ pF}$; see Figure 27
Insertion Loss	-0.7			dB typ	$R_L = 50\ \Omega$, $C_L = 5\text{ pF}$, $f = 1\text{ MHz}$; see Figure 27
C_S (Off)	19			pF typ	$V_S = 0\text{ V}$, $f = 1\text{ MHz}$
C_D (Off)	92			pF typ	$V_S = 0\text{ V}$, $f = 1\text{ MHz}$
C_D , C_S (On)	132			pF typ	$V_S = 0\text{ V}$, $f = 1\text{ MHz}$
POWER REQUIREMENTS					
I_{DD}	45			μA typ	$V_{DD} = +16.5\text{ V}$, $V_{SS} = -16.5\text{ V}$
	55		70	μA max	Digital inputs = 0 V or V_{DD}
I_{SS}	0.001			μA typ	Digital inputs = 0 V or V_{DD}
			1	μA max	
V_{DD}/V_{SS}			$\pm 9/\pm 22$	V min/max	GND = 0 V

¹ Guaranteed by design; not subject to production test.

±20 V DUAL SUPPLY

$V_{DD} = 20\text{ V} \pm 10\%$, $V_{SS} = -20\text{ V} \pm 10\%$, $GND = 0\text{ V}$, unless otherwise noted.

Table 2.

Parameter	25°C	-40°C to +85°C	-40°C to +125°C	Unit	Test Conditions/Comments
ANALOG SWITCH					
Analog Signal Range			V_{DD} to V_{SS}	V	
On Resistance, R_{ON}	9	13	15	Ω typ Ω max	$V_S = \pm 15\text{ V}$, $I_S = -10\text{ mA}$; see Figure 23 $V_{DD} = +18\text{ V}$, $V_{SS} = -18\text{ V}$
On-Resistance Match Between Channels, ΔR_{ON}	0.35			Ω typ	$V_S = \pm 15\text{ V}$, $I_S = -10\text{ mA}$
On-Resistance Flatness, $R_{FLAT(ON)}$	0.7	0.9	1.1	Ω max	$V_S = \pm 15\text{ V}$, $I_S = -10\text{ mA}$
	1.5			Ω typ	
	1.8	2.2	2.5	Ω max	
LEAKAGE CURRENTS					
Source Off Leakage, I_S (Off)	± 0.05			nA typ	$V_{DD} = +22\text{ V}$, $V_{SS} = -22\text{ V}$ $V_S = \pm 15\text{ V}$, $V_D = \mp 15\text{ V}$; see Figure 24
Drain Off Leakage, I_D (Off)	± 0.25	± 0.75	± 6	nA max	$V_S = \pm 15\text{ V}$, $V_D = \mp 15\text{ V}$; see Figure 24
	± 0.1			nA typ	
Channel On Leakage, I_D , I_S (On)	± 0.4	± 2	± 16	nA max	$V_S = V_D = \pm 15\text{ V}$; see Figure 25
	± 0.1			nA typ	
	± 0.4	± 2	± 16	nA max	
DIGITAL INPUTS					
Input High Voltage, V_{INH}			2.0	V min	$V_{IN} = V_{GND}$ or V_{DD}
Input Low Voltage, V_{INL}			0.8	V max	
Input Current, I_{INL} or I_{INH}	0.002			μA typ μA max	
Digital Input Capacitance, C_{IN}	5		± 0.1	pF typ	
DYNAMIC CHARACTERISTICS¹					
Transition Time, $t_{TRANSITION}$	175			ns typ	$R_L = 300\ \Omega$, $C_L = 35\text{ pF}$ $V_S = +10\text{ V}$; see Figure 30
	224	262	301	ns max	
t_{ON} (EN)	148			ns typ	$R_L = 300\ \Omega$, $C_L = 35\text{ pF}$ $V_S = 10\text{ V}$; see Figure 32
	185	222	250	ns max	
t_{OFF} (EN)	120			ns typ	$R_L = 300\ \Omega$, $C_L = 35\text{ pF}$ $V_S = 10\text{ V}$; see Figure 32
	142	159	173	ns max	
Break-Before-Make Time Delay, t_D	40		10	ns typ ns min	$R_L = 300\ \Omega$, $C_L = 35\text{ pF}$ $V_{S1} = V_{S2} = 10\text{ V}$; see Figure 31
Charge Injection, Q_{INJ}	290			pC typ	$V_S = 0\text{ V}$, $R_S = 0\ \Omega$, $C_L = 1\text{ nF}$; see Figure 33
Off Isolation	-78			dB typ	$R_L = 50\ \Omega$, $C_L = 5\text{ pF}$, $f = 100\text{ kHz}$; see Figure 26
Channel-to-Channel Crosstalk	-58			dB typ	$R_L = 50\ \Omega$, $C_L = 5\text{ pF}$, $f = 1\text{ MHz}$; see Figure 28
Total Harmonic Distortion + Noise	0.008			% typ	$R_L = 1\text{ k}\Omega$, 20 V p-p, $f = 20\text{ Hz}$ to 20 kHz; see Figure 29
-3 dB Bandwidth	54			MHz typ	$R_L = 50\ \Omega$, $C_L = 5\text{ pF}$; see Figure 27
Insertion Loss	-0.6			dB typ	$R_L = 50\ \Omega$, $C_L = 5\text{ pF}$, $f = 1\text{ MHz}$; see Figure 27
C_S (Off)	18			pF typ	$V_S = 0\text{ V}$, $f = 1\text{ MHz}$
C_D (Off)	88			pF typ	$V_S = 0\text{ V}$, $f = 1\text{ MHz}$
C_D , C_S (On)	129			pF typ	$V_S = 0\text{ V}$, $f = 1\text{ MHz}$
POWER REQUIREMENTS					
I_{DD}	50			μA typ	$V_{DD} = +22\text{ V}$, $V_{SS} = -22\text{ V}$ Digital inputs = 0 V or V_{DD}
	70		110	μA max	
I_{SS}	0.001			μA typ	Digital inputs = 0 V or V_{DD}
			1	μA max	
V_{DD}/V_{SS}			$\pm 9/\pm 22$	V min/max	$GND = 0\text{ V}$

¹ Guaranteed by design; not subject to production test.

+12 V SINGLE SUPPLY

$V_{DD} = 12\text{ V} \pm 10\%$, $V_{SS} = 0\text{ V}$, $GND = 0\text{ V}$, unless otherwise noted.

Table 3.

Parameter	25°C	-40°C to +85°C	-40°C to +125°C	Unit	Test Conditions/Comments
ANALOG SWITCH					
Analog Signal Range			0 V to V_{DD}	V	
On Resistance, R_{ON}	19			Ω typ	$V_S = 0\text{ V to }10\text{ V}$, $I_S = -10\text{ mA}$; see Figure 23
	22	27	31	Ω max	$V_{DD} = 10.8\text{ V}$, $V_{SS} = 0\text{ V}$
On-Resistance Match Between Channels, ΔR_{ON}	0.4			Ω typ	$V_S = 0\text{ V to }10\text{ V}$, $I_S = -10\text{ mA}$
	0.8	1	1.2	Ω max	
On-Resistance Flatness, $R_{FLAT(ON)}$	4.4			Ω typ	$V_S = 0\text{ V to }10\text{ V}$, $I_S = -10\text{ mA}$
	5.5	6.5	7.5	Ω max	
LEAKAGE CURRENTS					
Source Off Leakage, I_S (Off)	± 0.02			nA typ	$V_{DD} = 13.2\text{ V}$, $V_{SS} = 0\text{ V}$
	± 0.25	± 0.75	± 6	nA max	$V_S = 1\text{ V}/10\text{ V}$, $V_D = 10\text{ V}/1\text{ V}$; see Figure 24
Drain Off Leakage, I_D (Off)	± 0.05			nA typ	$V_S = 1\text{ V}/10\text{ V}$, $V_D = 10\text{ V}/1\text{ V}$; see Figure 24
	± 0.4	± 2	± 16	nA max	
Channel On Leakage, I_D , I_S (On)	± 0.05			nA typ	$V_S = V_D = 1\text{ V}/10\text{ V}$; see Figure 25
	± 0.4	± 2	± 16	nA max	
DIGITAL INPUTS					
Input High Voltage, V_{INH}			2.0	V min	
Input Low Voltage, V_{INL}			0.8	V max	
Input Current, I_{INL} or I_{INH}	0.002			μA typ	$V_{IN} = V_{GND}$ or V_{DD}
			± 0.1	μA max	
Digital Input Capacitance, C_{IN}	5			pF typ	
DYNAMIC CHARACTERISTICS¹					
Transition Time, $t_{TRANSITION}$	266			ns typ	$R_L = 300\ \Omega$, $C_L = 35\text{ pF}$
	358	446	515	ns max	$V_S = +8\text{ V}$; see Figure 30
t_{ON} (EN)	260			ns typ	$R_L = 300\ \Omega$, $C_L = 35\text{ pF}$
	339	423	485	ns max	$V_S = 8\text{ V}$; see Figure 32
t_{OFF} (EN)	135			ns typ	$R_L = 300\ \Omega$, $C_L = 35\text{ pF}$
	162	189	210	ns max	$V_S = 8\text{ V}$; see Figure 32
Break-Before-Make Time Delay, t_D	125			ns typ	$R_L = 300\ \Omega$, $C_L = 35\text{ pF}$
			45	ns min	$V_{S1} = V_{S2} = 8\text{ V}$; see Figure 31
Charge Injection, Q_{INJ}	92			pC typ	$V_S = 6\text{ V}$, $R_S = 0\ \Omega$, $C_L = 1\text{ nF}$; see Figure 33
Off Isolation	-78			dB typ	$R_L = 50\ \Omega$, $C_L = 5\text{ pF}$, $f = 1\text{ MHz}$; see Figure 26
Channel-to-Channel Crosstalk	-58			dB typ	$R_L = 50\ \Omega$, $C_L = 5\text{ pF}$, $f = 1\text{ MHz}$; see Figure 28
Total Harmonic Distortion + Noise	0.075			% typ	$R_L = 1\text{ k}\ \Omega$, 6 V p-p, $f = 20\text{ Hz to }20\text{ kHz}$; see Figure 29
-3 dB Bandwidth	43			MHz typ	$R_L = 50\ \Omega$, $C_L = 5\text{ pF}$; see Figure 27
Insertion Loss	-1.36			dB typ	$R_L = 50\ \Omega$, $C_L = 5\text{ pF}$, $f = 1\text{ MHz}$; see Figure 27
C_S (Off)	22			pF typ	$V_S = 6\text{ V}$, $f = 1\text{ MHz}$
C_D (Off)	105			pF typ	$V_S = 6\text{ V}$, $f = 1\text{ MHz}$
C_D , C_S (On)	140			pF typ	$V_S = 6\text{ V}$, $f = 1\text{ MHz}$
POWER REQUIREMENTS					
I_{DD}	40			μA typ	$V_{DD} = 13.2\text{ V}$
	50		65	μA max	Digital inputs = 0 V or V_{DD}
V_{DD}			9/40	V min/max	$GND = 0\text{ V}$, $V_{SS} = 0\text{ V}$

¹ Guaranteed by design; not subject to production test.

+36 V SINGLE SUPPLY

$V_{DD} = 36\text{ V} \pm 10\%$, $V_{SS} = 0\text{ V}$, $GND = 0\text{ V}$, unless otherwise noted.

Table 4.

Parameter	25°C	−40°C to +85°C	−40°C to +125°C	Unit	Test Conditions/Comments
ANALOG SWITCH					
Analog Signal Range			0 V to V_{DD}	V	
On Resistance, R_{ON}	10.6 12	15	17	Ω typ Ω max	$V_S = 0\text{ V}$ to 30 V, $I_S = -10\text{ mA}$; see Figure 23 $V_{DD} = 32.4\text{ V}$, $V_{SS} = 0\text{ V}$
On-Resistance Match Between Channels, ΔR_{ON}	0.35			Ω typ	$V_S = 0\text{ V}$ to 30 V, $I_S = -10\text{ mA}$
On-Resistance Flatness, $R_{FLAT(ON)}$	0.7	0.9	1.1	Ω max	$V_S = 0\text{ V}$ to 30 V, $I_S = -10\text{ mA}$
	2.7			Ω typ	
	3.2	3.8	4.5	Ω max	
LEAKAGE CURRENTS					
Source Off Leakage, I_S (Off)	± 0.05 ± 0.25	± 0.75	± 6	nA typ nA max	$V_{DD} = 39.6\text{ V}$, $V_{SS} = 0\text{ V}$ $V_S = 1\text{ V}/30\text{ V}$, $V_D = 30\text{ V}/1\text{ V}$; see Figure 24
Drain Off Leakage, I_D (Off)	± 0.1			nA typ	$V_S = 1\text{ V}/30\text{ V}$, $V_D = 30\text{ V}/1\text{ V}$; see Figure 24
Channel On Leakage, I_D , I_S (On)	± 0.4	± 2	± 16	nA max	
	± 0.1 ± 0.4	± 2	± 16	nA typ nA max	$V_S = V_D = 1\text{ V}/30\text{ V}$; see Figure 25
DIGITAL INPUTS					
Input High Voltage, V_{INH}			2.0	V min	$V_{IN} = V_{GND}$ or V_{DD}
Input Low Voltage, V_{INL}			0.8	V max	
Input Current, I_{INL} or I_{INH}	0.002			μA typ	
			± 0.1	μA max	
Digital Input Capacitance, C_{IN}	5			pF typ	
DYNAMIC CHARACTERISTICS¹					
Transition Time, $t_{TRANSITION}$	196			ns typ	$R_L = 300\ \Omega$, $C_L = 35\text{ pF}$ $V_S = 18\text{ V}$; see Figure 30
	256	276	314	ns max	
t_{ON} (EN)	170			ns typ	$R_L = 300\ \Omega$, $C_L = 35\text{ pF}$ $V_S = 18\text{ V}$; see Figure 32
	214	247	273	ns max	
t_{OFF} (EN)	130			ns typ	$R_L = 300\ \Omega$, $C_L = 35\text{ pF}$ $V_S = 18\text{ V}$; see Figure 32
	172	167	176	ns max	
Break-Before-Make Time Delay, t_D	52			ns typ	$R_L = 300\ \Omega$, $C_L = 35\text{ pF}$ $V_{S1} = V_{S2} = 18\text{ V}$; see Figure 31
			13	ns min	
Charge Injection, Q_{INJ}	280			pC typ	$V_S = 18\text{ V}$, $R_S = 0\ \Omega$, $C_L = 1\text{ nF}$; see Figure 33
Off Isolation	−78			dB typ	$R_L = 50\ \Omega$, $C_L = 5\text{ pF}$, $f = 1\text{ MHz}$; see Figure 26
Channel-to-Channel Crosstalk	−58			dB typ	$R_L = 50\ \Omega$, $C_L = 5\text{ pF}$, $f = 1\text{ MHz}$; see Figure 28
Total Harmonic Distortion + Noise	0.03			% typ	$R_L = 1\text{ k}\ \Omega$, 18 V p-p, $f = 20\text{ Hz}$ to 20 kHz; see Figure 29
−3 dB Bandwidth	47			MHz typ	$R_L = 50\ \Omega$, $C_L = 5\text{ pF}$; see Figure 27
Insertion Loss	−0.85			dB typ	$R_L = 50\ \Omega$, $C_L = 5\text{ pF}$, $f = 1\text{ MHz}$; see Figure 27
C_S (Off)	18			pF typ	$V_S = 18\text{ V}$, $f = 1\text{ MHz}$
C_D (Off)	89			pF typ	$V_S = 18\text{ V}$, $f = 1\text{ MHz}$
C_D , C_S (On)	128			pF typ	$V_S = 18\text{ V}$, $f = 1\text{ MHz}$
POWER REQUIREMENTS					
I_{DD}	80			μA typ	$V_{DD} = 39.6\text{ V}$ Digital inputs = 0 V or V_{DD}
	100		130	μA max	
V_{DD}			9/40	V min/max	$GND = 0\text{ V}$, $V_{SS} = 0\text{ V}$

¹ Guaranteed by design; not subject to production test.

CONTINUOUS CURRENT PER CHANNEL, S OR D

Table 5.

Parameter	25°C	85°C	125°C	Unit
CONTINUOUS CURRENT, S OR D				
$V_{DD} = +15\text{ V}, V_{SS} = -15\text{ V}$				
TSSOP ($\theta_{JA} = 112.6^\circ\text{C/W}$)	165	96	49	mA max
LFCSP ($\theta_{JA} = 30.4^\circ\text{C/W}$)	290	141	57	mA max
$V_{DD} = +20\text{ V}, V_{SS} = -20\text{ V}$				
TSSOP ($\theta_{JA} = 112.6^\circ\text{C/W}$)	176	101	51	mA max
LFCSP ($\theta_{JA} = 30.4^\circ\text{C/W}$)	282	146	58	mA max
$V_{DD} = 12\text{ V}, V_{SS} = 0\text{ V}$				
TSSOP ($\theta_{JA} = 112.6^\circ\text{C/W}$)	114	72	42	mA max
LFCSP ($\theta_{JA} = 30.4^\circ\text{C/W}$)	203	112	53	mA max
$V_{DD} = 36\text{ V}, V_{SS} = 0\text{ V}$				
TSSOP ($\theta_{JA} = 112.6^\circ\text{C/W}$)	149	89	48	mA max
LFCSP ($\theta_{JA} = 30.4^\circ\text{C/W}$)	263	133	56	mA max

ABSOLUTE MAXIMUM RATINGS

$T_A = 25^\circ\text{C}$, unless otherwise noted.

Table 6.

Parameter	Rating
V_{DD} to V_{SS}	48 V
V_{DD} to GND	-0.3 V to +48 V
V_{SS} to GND	+0.3 V to -48 V
Analog Inputs ¹	$V_{SS} - 0.3\text{ V}$ to $V_{DD} + 0.3\text{ V}$ or 30 mA, whichever occurs first
Digital Inputs ¹	$V_{SS} - 0.3\text{ V}$ to $V_{DD} + 0.3\text{ V}$ or 30 mA, whichever occurs first
Peak Current, Sx or D Pins	515 mA (pulsed at 1 ms, 10% duty cycle maximum)
Continuous Current, S or D ²	Data + 15%
Operating Temperature Range	-40°C to +125°C
Storage Temperature Range	-65°C to +150°C
Junction Temperature	150°C
Thermal Impedance, θ_{JA}	
16-Lead TSSOP, θ_{JA} Thermal Impedance (4-Layer Board)	112.6°C/W
16-Lead LFCSP, θ_{JA} Thermal Impedance (4-Layer Board)	30.4°C/W
Reflow Soldering Peak Temperature, Pb Free	260(+0/-5)°C

¹ Overvoltages at the Sx and D pins are clamped by internal diodes. Limit current to the maximum ratings given.

² See Table 5.

Stresses at or above those listed under Absolute Maximum Ratings may cause permanent damage to the product. This is a stress rating only; functional operation of the product at these or any other conditions above those indicated in the operational section of this specification is not implied. Operation beyond the maximum operating conditions for extended periods may affect product reliability.

Only one absolute maximum rating can be applied at any one time.

ESD CAUTION



ESD (electrostatic discharge) sensitive device. Charged devices and circuit boards can discharge without detection. Although this product features patented or proprietary protection circuitry, damage may occur on devices subjected to high energy ESD. Therefore, proper ESD precautions should be taken to avoid performance degradation or loss of functionality.

PIN CONFIGURATIONS AND FUNCTION DESCRIPTIONS

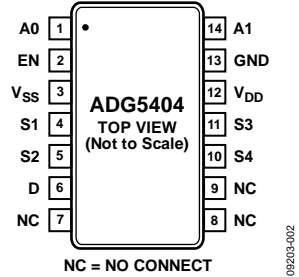
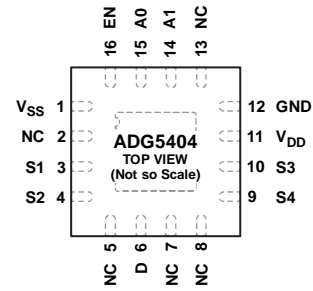

Figure 2. TSSOP Pin Configuration



- NOTES
 1. NC = NO CONNECT.
 2. EXPOSED PAD TIED TO SUBSTRATE, V_{SS}.

Figure 3. LFCSP Pin Configuration

Table 7. Pin Function Descriptions

Pin No.		Mnemonic	Description
TSSOP	LFCSP		
1	15	A0	Logic Control Input.
2	16	EN	Active High Digital Input. When this pin is low, the device is disabled and all switches are off. When this pin is high, the Ax logic inputs determine the on switches.
3	1	V _{SS}	Most Negative Power Supply Potential.
4	3	S1	Source Terminal. Can be an input or an output.
5	4	S2	Source Terminal. Can be an input or an output.
6	6	D	Drain Terminal. Can be an input or an output.
7 to 9	2, 5, 7, 8, 13	NC	No Connection.
10	9	S4	Source Terminal. Can be an input or an output.
11	10	S3	Source Terminal. Can be an input or an output.
12	11	V _{DD}	Most Positive Power Supply Potential.
13	12	GND	Ground (0 V) Reference.
14	14	A1	Logic Control Input.
	EP	Exposed Pad	The exposed pad is connected internally. For increased reliability of the solder joints and maximum thermal capability, it is recommended that the pad be soldered to the substrate, V _{SS} .

TRUTH TABLE

Table 8.

EN	A1	A0	S1	S2	S3	S4
0	X ¹	X ¹	Off	Off	Off	Off
1	0	0	On	Off	Off	Off
1	0	1	Off	On	Off	Off
1	1	0	Off	Off	On	Off
1	1	1	Off	Off	Off	On

¹X = don't care.

TYPICAL PERFORMANCE CHARACTERISTICS

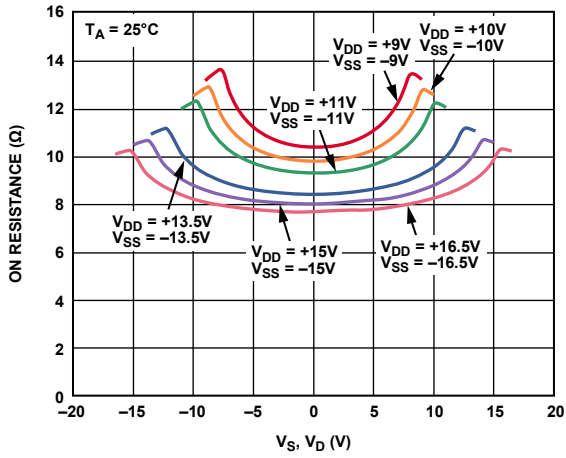

Figure 4. R_{ON} as a Function of V_D (V_S), Dual Supply

09203-029

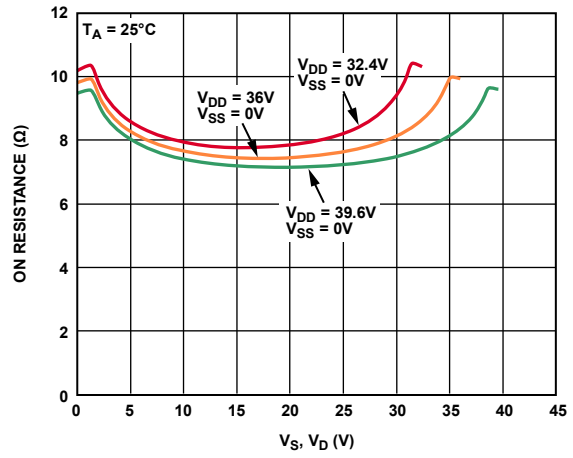

Figure 7. R_{ON} as a Function of V_D (V_S), Single Supply

09203-028

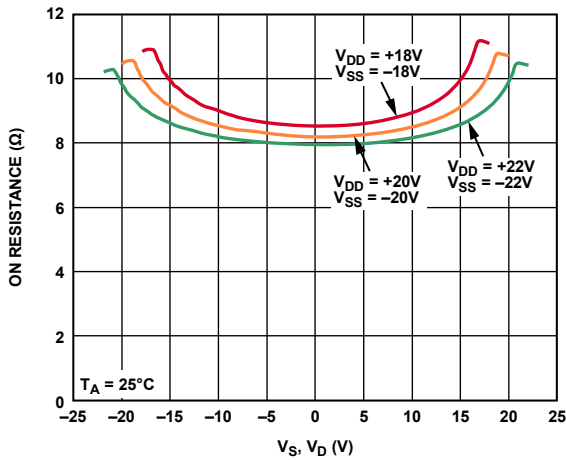

Figure 5. R_{ON} as a Function of V_D (V_S), Dual Supply

09203-030

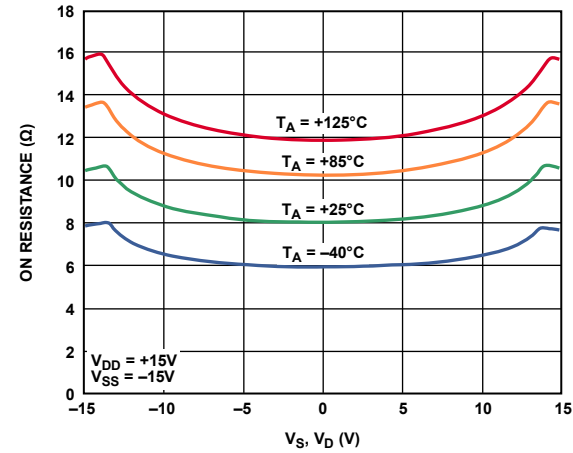

Figure 8. R_{ON} as a Function of V_D (V_S) for Different Temperatures, ± 15 V Dual Supply

09203-023

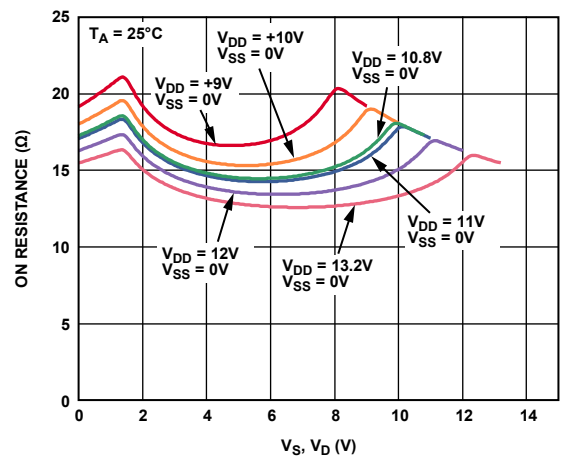

Figure 6. R_{ON} as a Function of V_D (V_S), Single Supply

09203-027

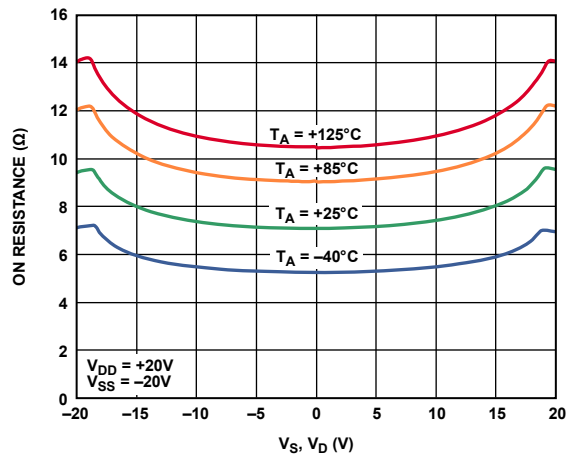

Figure 9. R_{ON} as a Function of V_D (V_S) for Different Temperatures, ± 20 V Dual Supply

09203-024

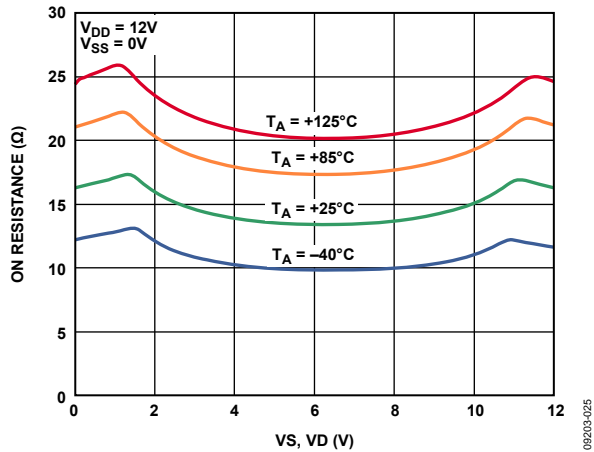

Figure 10. R_{ON} as a Function of V_D (V_S) for Different Temperatures, 12 V Single Supply

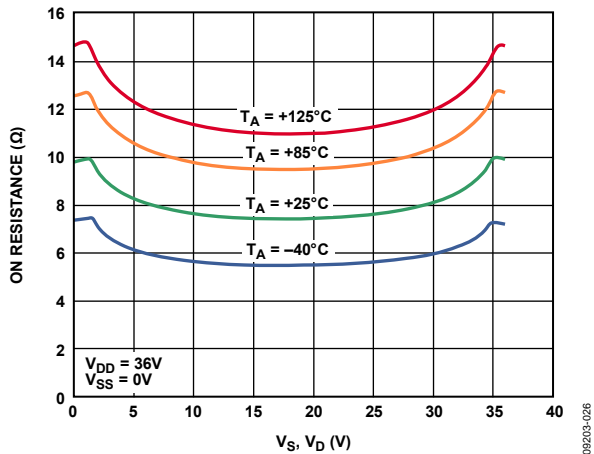

Figure 11. R_{ON} as a Function of V_D (V_S) for Different Temperatures, 36 V Single Supply

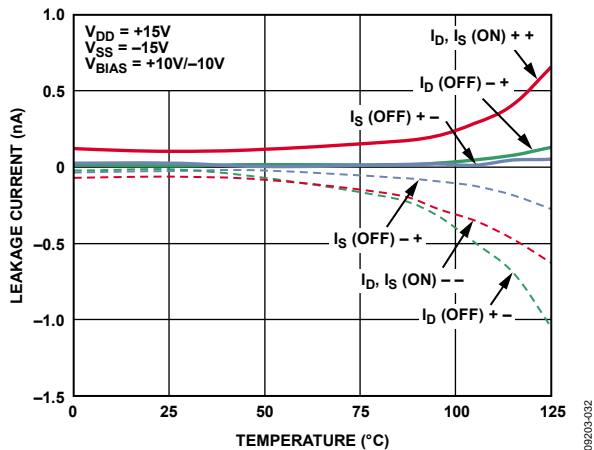

Figure 12. Leakage Currents vs. Temperature, ± 15 V Dual Supply

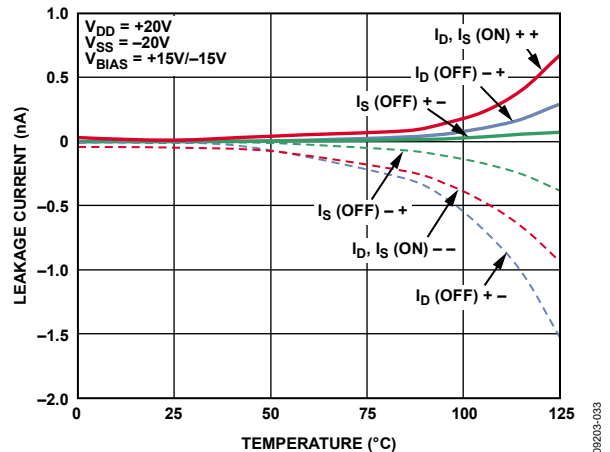

Figure 13. Leakage Currents vs. Temperature, ± 20 V Dual Supply

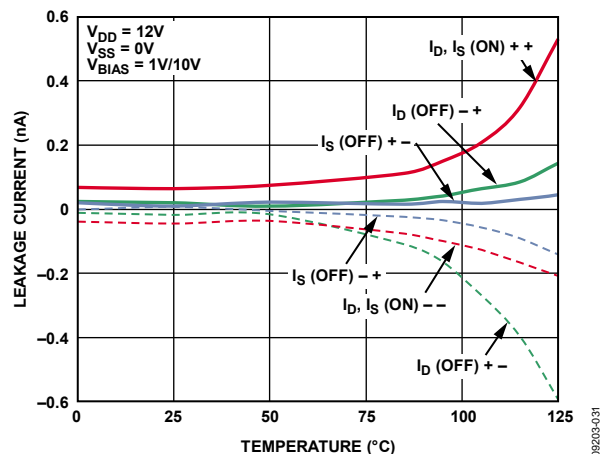

Figure 14. Leakage Currents vs. Temperature, 12 V Single Supply

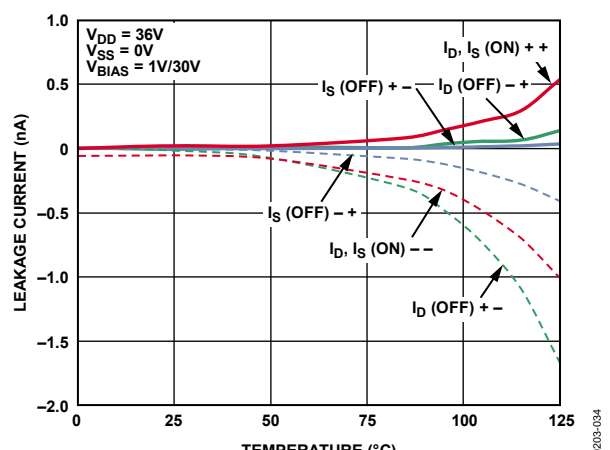

Figure 15. Leakage Currents vs. Temperature, 36 V Single Supply

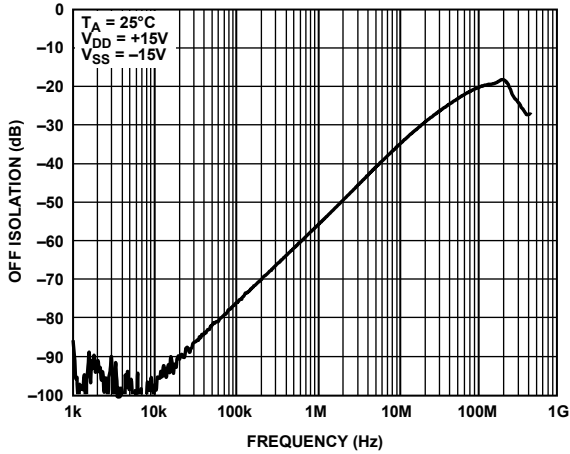

Figure 16. Off Isolation vs. Frequency, $\pm 15\text{ V}$ Dual Supply

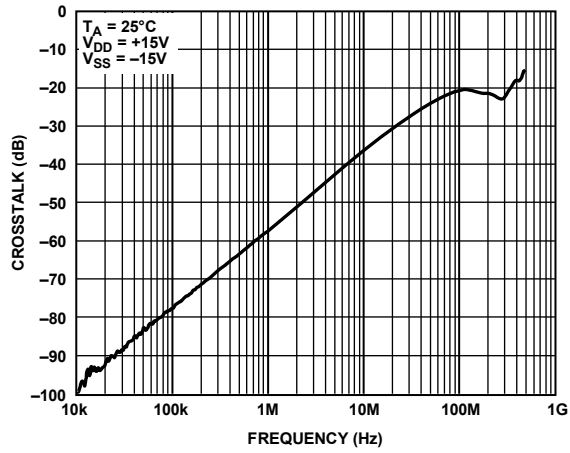

Figure 17. Crosstalk vs. Frequency, $\pm 15\text{ V}$ Dual Supply

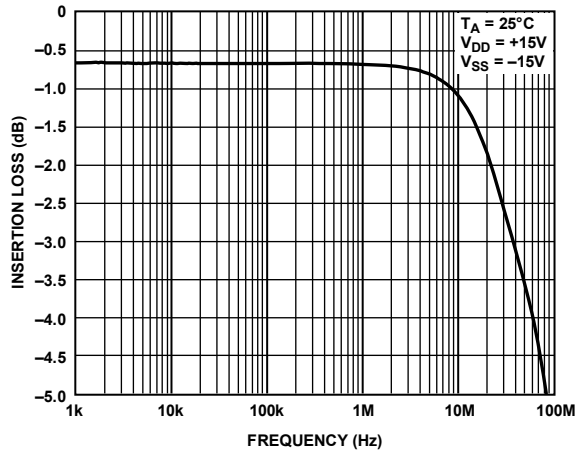

Figure 18. On Response vs. Frequency, $\pm 15\text{ V}$ Dual Supply

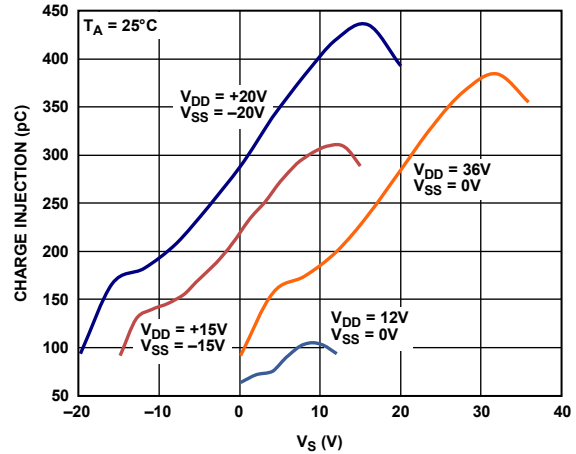

Figure 19. Charge Injection vs. Source Voltage

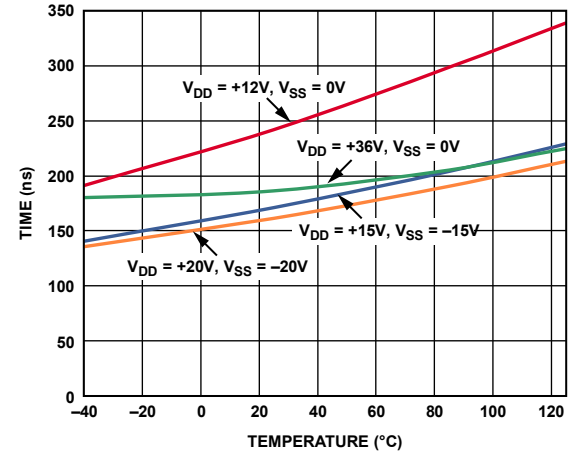

Figure 20. Transition Time vs. Temperature

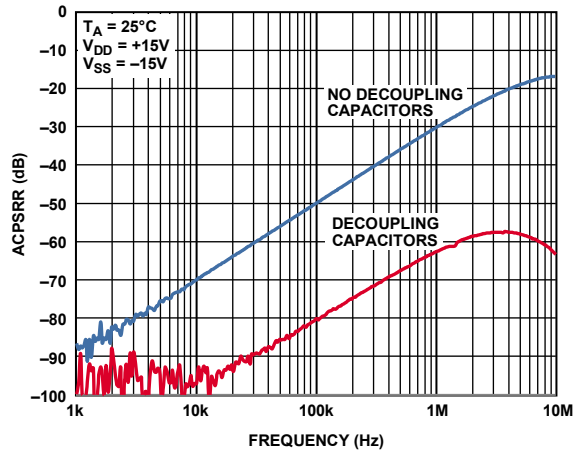

Figure 21. ACPSRR vs. Frequency, $\pm 15\text{ V}$ Dual Supply

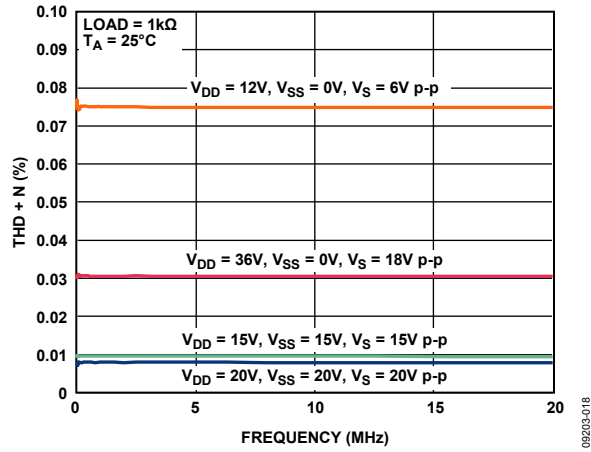

Figure 22. THD + N vs. Frequency, ±15 V Dual Supply

TEST CIRCUITS

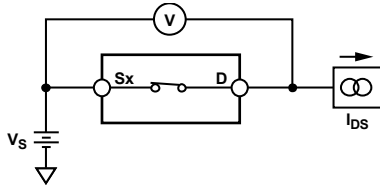
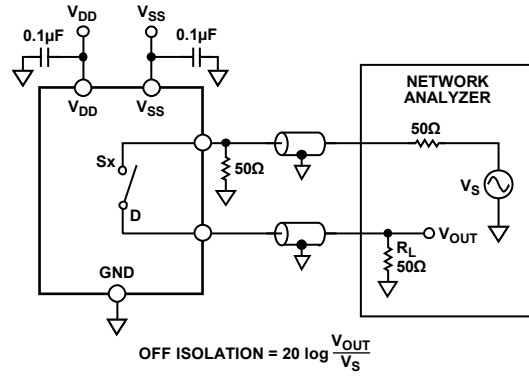

Figure 23. On Resistance

09203-005



$$\text{OFF ISOLATION} = 20 \log \frac{V_{\text{OUT}}}{V_s}$$

Figure 26. Off Isolation

09203-008

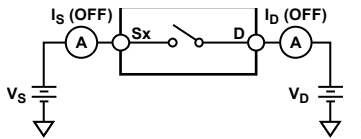
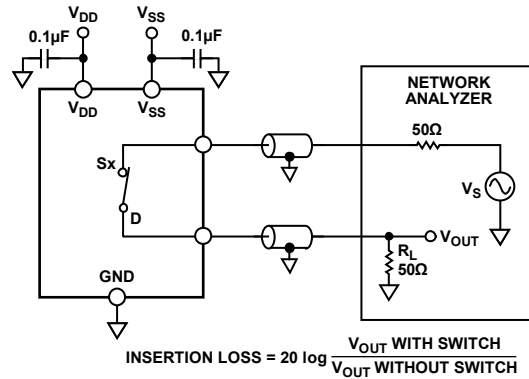

Figure 24. Off Leakage

09203-006



$$\text{INSERTION LOSS} = 20 \log \frac{V_{\text{OUT WITH SWITCH}}}{V_{\text{OUT WITHOUT SWITCH}}}$$

Figure 27. Bandwidth

09203-009

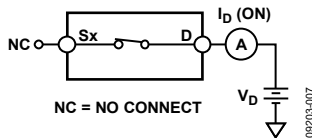

NC = NO CONNECT

Figure 25. On Leakage

09203-007

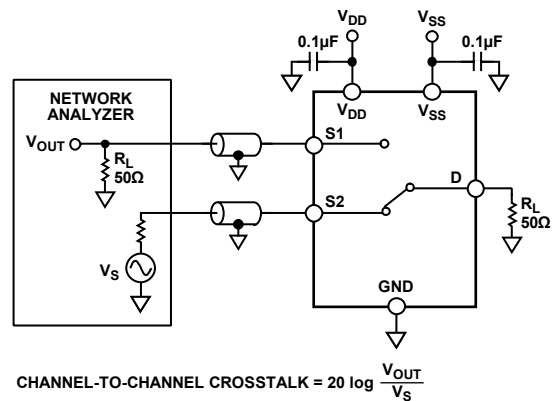

$$\text{CHANNEL-TO-CHANNEL CROSSTALK} = 20 \log \frac{V_{\text{OUT}}}{V_s}$$

Figure 28. Channel-to-Channel Crosstalk

09203-010

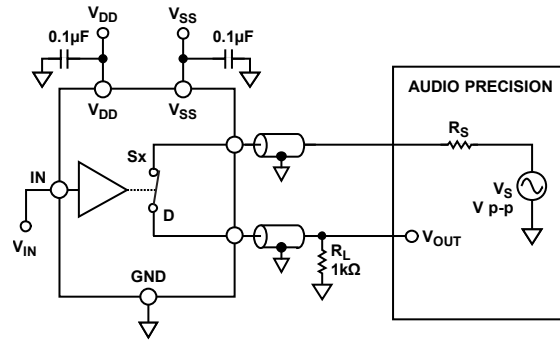

Figure 29. THD + Noise

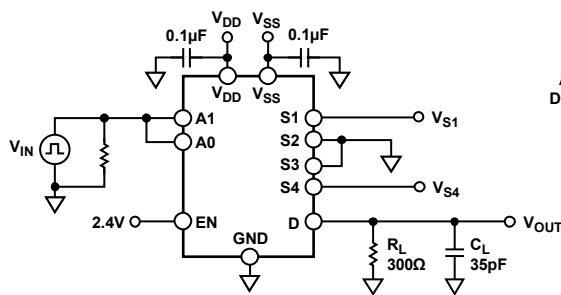

Figure 30. Address to Output Switching Times

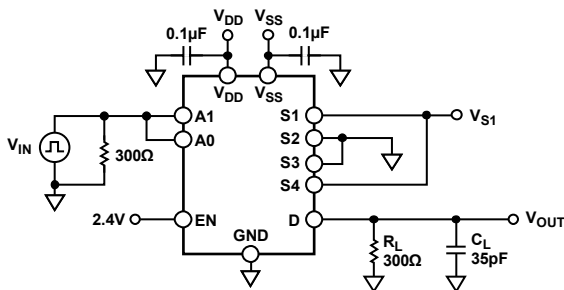
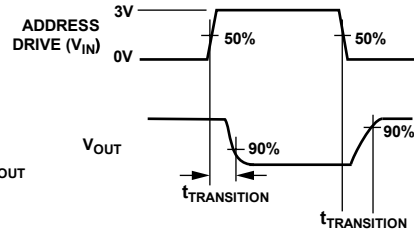
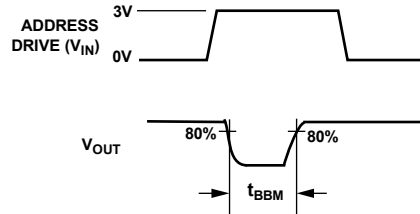

Figure 31. Break-Before-Make Time Delay



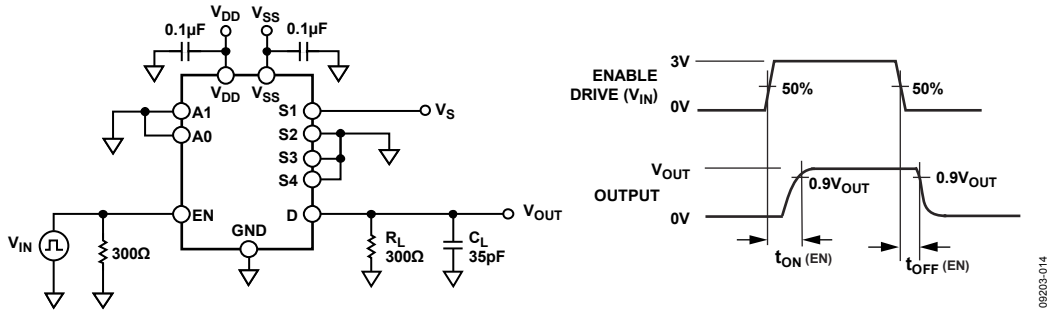

Figure 32. Enable-to-Output Switching Delay

092203-014

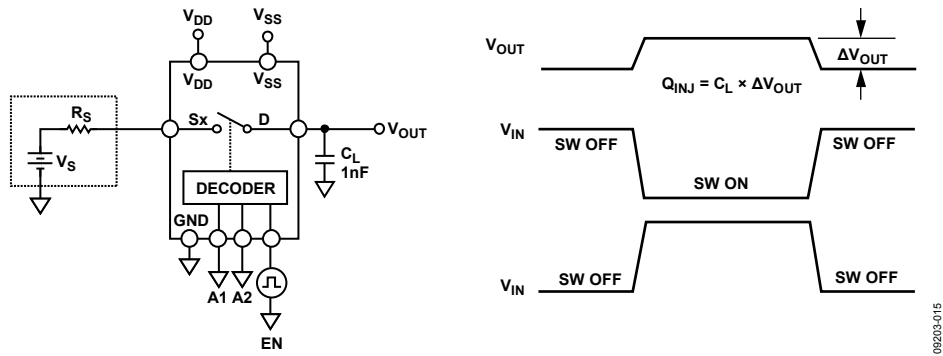

Figure 33. Charge Injection

092203-015

TERMINOLOGY

I_{DD}

The positive supply current.

I_{SS}

The negative supply current.

V_D (V_S)

The analog voltage on Terminal D and Terminal S.

R_{ON}

The ohmic resistance between Terminal D and Terminal S.

R_{FLAT(ON)}

Flatness that is defined as the difference between the maximum and minimum value of on resistance measured over the specified analog signal range.

I_S (Off)

The source leakage current with the switch off.

I_D (Off)

The drain leakage current with the switch off.

I_D, I_S (On)

The channel leakage current with the switch on.

V_{INL}

The maximum input voltage for Logic 0.

V_{INH}

The minimum input voltage for Logic 1.

I_{INL} (I_{INH})

The input current of the digital input.

C_S (Off)

The off switch source capacitance, which is measured with reference to ground.

C_D (Off)

The off switch drain capacitance, which is measured with reference to ground.

C_D, C_S (On)

The on switch capacitance, which is measured with reference to ground.

C_{IN}

The digital input capacitance.

t_{TRANSITION}

The delay time between the 50% and 90% points of the digital input and switch-on condition when switching from one address state to another.

t_{ON} (EN)

The delay between applying the digital control input and the output switching on. See Figure 32.

t_{OFF} (EN)

The delay between applying the digital control input and the output switching off.

Charge Injection

A measure of the glitch impulse transferred from the digital input to the analog output during switching.

Off Isolation

A measure of unwanted signal coupling through an off switch.

Crosstalk

A measure of unwanted signal that is coupled through from one channel to another as a result of parasitic capacitance.

Bandwidth

The frequency at which the output is attenuated by 3 dB.

On Response

The frequency response of the on switch.

Insertion Loss

The loss due to the on resistance of the switch.

THD + N

The ratio of the harmonic amplitude plus noise of the signal to the fundamental.

ACPSRR (AC Power Supply Rejection Ratio)

The ratio of the amplitude of signal on the output to the amplitude of the modulation. This is a measure of the part's ability to avoid coupling noise and spurious signals that appear on the supply voltage pin to the output of the switch. The dc voltage on the device is modulated by a sine wave of 0.62 V p-p.

TRENCH ISOLATION

In the ADG5404, an insulating oxide layer (trench) is placed between the NMOS and the PMOS transistors of each CMOS switch. Parasitic junctions, which occur between the transistors in junction-isolated switches, are eliminated, and the result is a completely latch-up proof switch.

In junction isolation, the N and P wells of the PMOS and NMOS transistors form a diode that is reverse-biased under normal operation. However, during overvoltage conditions, this diode can become forward-biased. A silicon-controlled rectifier (SCR) type circuit is formed by the two transistors, causing a significant amplification of the current that, in turn, leads to latch-up. With trench isolation, this diode is removed, and the result is a latch-up proof switch.

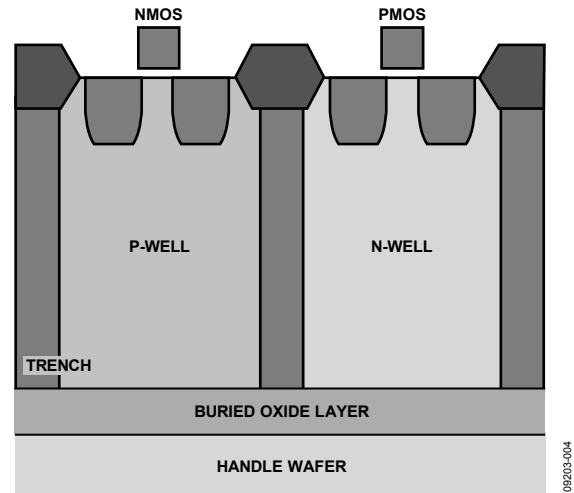

Figure 34. Trench Isolation

APPLICATIONS INFORMATION

The ADG54xx family of switches and multiplexers provide a robust solution for instrumentation, industrial, automotive, aerospace, and other harsh environments that are prone to latch-up, which is an undesirable high current state that can lead to device failure and persists until the power supply is turned off. The ADG5404 high voltage multiplexer allows

single-supply operation from 9 V to 40 V and dual-supply operation from ± 9 V to ± 22 V. The ADG5404, as well as three other ADG54xx family members, [ADG5412/ADG5413](#) and [ADG5436](#), achieve an 8 kV human body model ESD rating that provides a robust solution and eliminates the need for separate protection circuitry designs in some applications.

OUTLINE DIMENSIONS

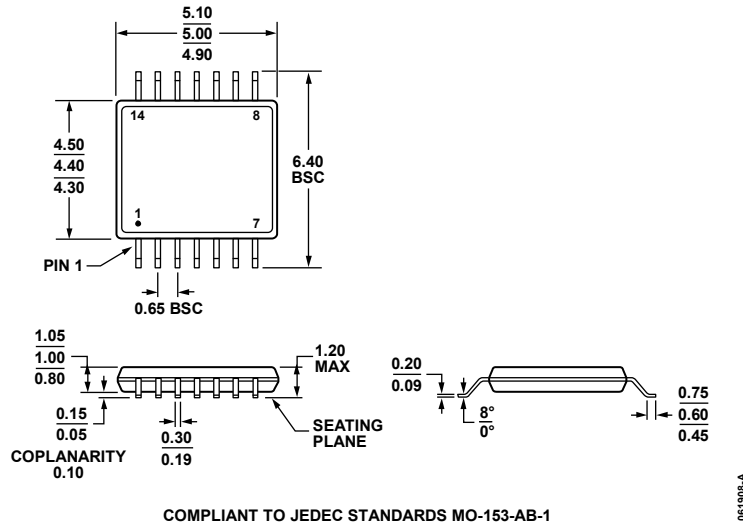

COMPLIANT TO JEDEC STANDARDS MO-153-AB-1
 Figure 35. 14-Lead Thin Shrink Small Outline Package [TSSOP] (RU-14)
 Dimensions shown in millimeters

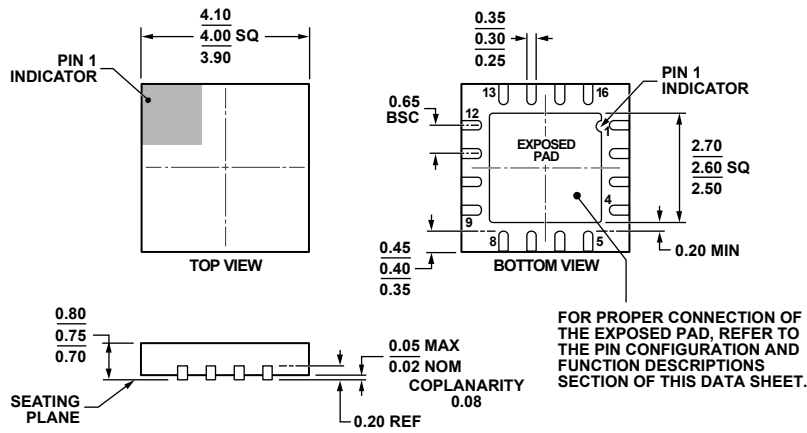

COMPLIANT TO JEDEC STANDARDS MO-220-WGGC.
 Figure 36. 16-Lead Lead Frame Chip Scale Package [LFCSP] 4 mm x 4 mm Body and 0.75 mm Package Height (CP-16-17)
 Dimensions shown in millimeters

ORDERING GUIDE

Model ¹	Temperature Range	Package Description	Package Option
ADG5404BRUZ	-40°C to +125°C	14-Lead Thin Shrink Small Outline Package [TSSOP]	RU-14
ADG5404BRUZ-REEL7	-40°C to +125°C	14-Lead Thin Shrink Small Outline Package [TSSOP]	RU-14
ADG5404BCPZ-REEL7	-40°C to +125°C	16-Lead Lead Frame Chip Scale Package [LFCSP]	CP-16-17

¹ Z = RoHS Compliant Part.

Looking for pricing, stock, or lifecycle information?

Click below to explore more details on WIN SOURCE:

 [View ADG5404BRUZ-REEL7 on WIN SOURCE](#)

 [Analog Devices Inc. Information](#)

Optimize Your Supply Chain with WIN SOURCE Solutions

-  Global Sourcing Solution
-  Obsolete Management
-  Cost Control Management
-  Shortage Management
-  Alternative Solution
-  Excess Inventory Management