



**THE DATASHEET OF
ULN2803ADWRG4**



ULN2803A Darlington Transistor Arrays

1 Features

- 500-mA-Rated Collector Current (Single Output)
- High-Voltage Outputs: 50 V
- Output Clamp Diodes
- Inputs Compatible With Various Types of Logic

2 Applications

- Relay Drivers
- Hammer Drivers
- Lamp Drivers
- Display Drivers (LED and Gas Discharge)
- Line Drivers
- Logic Buffers
- Stepper Motors
- IP Camera
- HVAC Valve and LED Dot Matrix

3 Description

The ULN2803A device is a 50 V, 500 mA Darlington transistor array. The device consists of eight NPN Darlington pairs that feature high-voltage outputs with common-cathode clamp diodes for switching inductive loads. The collector-current rating of each Darlington pair is 500 mA. The Darlington pairs may be connected in parallel for higher current capability.

Applications include relay drivers, hammer drivers, lamp drivers, display drivers (LED and gas discharge), line drivers, and logic buffers. The ULN2803A device has a 2.7-kΩ series base resistor for each Darlington pair for operation directly with TTL or 5-V CMOS devices.

Device Information⁽¹⁾

PART NUMBER	PACKAGE	BODY SIZE (NOM)
ULN2803ADW	SOIC (18)	11.55 mm x 7.50 mm

(1) For all available packages, see the orderable addendum at the end of the data sheet.

Logic Diagram

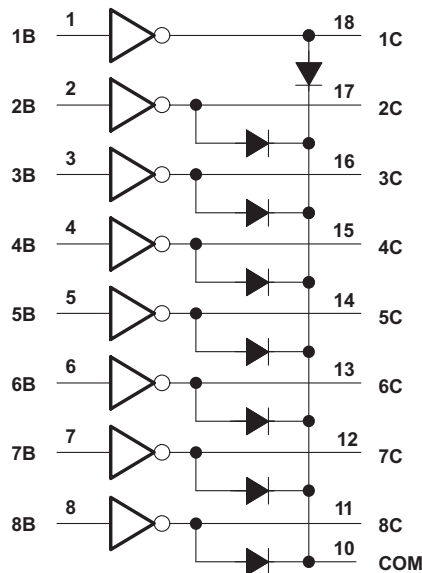

Table of Contents

1 Features 1 2 Applications 1 3 Description 1 4 Revision History 2 5 Pin Configuration and Functions 3 6 Specifications 4 6.1 Absolute Maximum Ratings 4 6.2 ESD Ratings 4 6.3 Recommended Operating Conditions 4 6.4 Thermal Information 4 6.5 Electrical Characteristics 5 6.6 Switching Characteristics 5 6.7 Typical Characteristics 5 7 Parameter Measurement Information 6 8 Detailed Description 9 8.1 Overview 9 8.2 Functional Block Diagram 9	8.3 Feature Description 9 8.4 Device Functional Modes 9 9 Application and Implementation 10 9.1 Application Information 10 9.2 Typical Application 10 10 Power Supply Recommendations 12 11 Layout 12 11.1 Layout Guidelines 12 11.2 Layout Example 12 12 Device and Documentation Support 13 12.1 Receiving Notification of Documentation Updates 13 12.2 Community Resources 13 12.3 Trademarks 13 12.4 Electrostatic Discharge Caution 13 12.5 Glossary 13 13 Mechanical, Packaging, and Orderable Information 13
---	--

4 Revision History

NOTE: Page numbers for previous revisions may differ from page numbers in the current version.

Changes from Revision G (January 2015) to Revision H	Page
• Deleted obsolete orderable ULN2803AN and removed all references to N package	1
• Added Storage temperature, T_{stg} in <i>Absolute Maximum Ratings</i>	4
• Deleted V_I from <i>Recommended Operating Conditions</i>	4
• Added Ambient temperature, T_A in <i>Recommended Operating Conditions</i>	4
• Changed coil supply voltage specifications in <i>Design Parameters</i>	11
• Added <i>Receiving Notification of Documentation Updates</i> section and <i>Community Resources</i> section	13

Changes from Revision F (January 2014) to Revision G	Page
• Added <i>Applications</i> , <i>Device Information</i> table, <i>Pin Functions</i> table, <i>ESD Ratings</i> table, <i>Thermal Information</i> table, <i>Typical Characteristics</i> , <i>Feature Description</i> section, <i>Device Functional Modes</i> , <i>Application and Implementation</i> section, <i>Power Supply Recommendations</i> section, <i>Layout</i> section, <i>Device and Documentation Support</i> section, and <i>Mechanical, Packaging, and Orderable Information</i> section.	1

Changes from Revision E (July 2006) to Revision F	Page
• Updated document to new TI data sheet format - no specification changes.	1
• Deleted <i>Ordering Information</i> table.	1

5 Pin Configuration and Functions

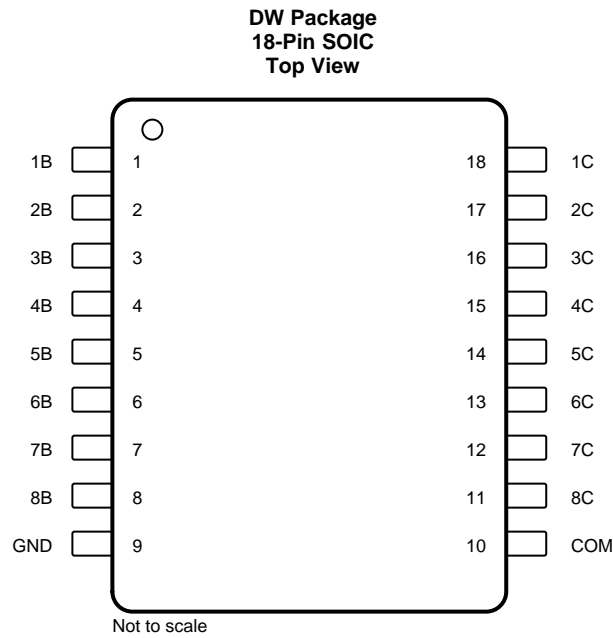

Pin Functions

PIN		TYPE	DESCRIPTION
NAME	NO.		
1B	1	I	Channel 1 through 8 Darlington base input
2B	2		
3B	3		
4B	4		
5B	5		
6B	6		
7B	7		
8B	8		
1C	18	O	Channel 1 through 8 Darlington collector output
2C	17		
3C	16		
4C	15		
5C	14		
6C	13		
7C	12		
8C	11		
GND	9	—	Common emitter shared by all channels (typically tied to ground)
COM	10	I/O	Common cathode node for flyback diodes (required for inductive loads)

6 Specifications

6.1 Absolute Maximum Ratings

 at 25°C free-air temperature (unless otherwise noted)⁽¹⁾

		MIN	MAX	UNIT
V _{CE}	Collector-emitter voltage		50	V
V _I	Input voltage ⁽²⁾		30	V
	Peak collector current		500	mA
I(clamp)	Output clamp current		500	mA
	Total substrate-terminal current		–2.5	A
T _J	Junction temperature	–65	150	°C
T _{stg}	Storage temperature	–65	150	°C

- (1) Stresses beyond those listed under *Absolute Maximum Ratings* may cause permanent damage to the device. These are stress ratings only, which do not imply functional operation of the device at these or any other conditions beyond those indicated under *Recommended Operating Conditions*. Exposure to absolute-maximum-rated conditions for extended periods may affect device reliability.
- (2) All voltage values, unless otherwise noted, are with respect to the emitter/substrate terminal GND.

6.2 ESD Ratings

		VALUE	UNIT
V _(ESD)	Electrostatic discharge	Human body model (HBM), per ANSI/ESDA/JEDEC JS-001 ⁽¹⁾	±2000
		Charged device model (CDM), per JEDEC specification JESD22-C101 ⁽²⁾	±500

- (1) JEDEC document JEP155 states that 500-V HBM allows safe manufacturing with a standard ESD control process.
- (2) JEDEC document JEP157 states that 250-V CDM allows safe manufacturing with a standard ESD control process.

6.3 Recommended Operating Conditions

over operating free-air temperature range (unless otherwise noted)

		MIN	MAX	UNIT
V _{CE}	Collector-emitter voltage	0	50	V
T _A	Ambient temperature	–40	85	°C

6.4 Thermal Information

THERMAL METRIC ⁽¹⁾		ULN2803A	UNIT
		DW (SOIC)	
		18 PINS	
R _{θJA}	Junction-to-ambient thermal resistance	66.4	°C/W
R _{θJC(top)}	Junction-to-case (top) thermal resistance	29.5	°C/W
R _{θJB}	Junction-to-board thermal resistance	33.0	°C/W
ψ _{JT}	Junction-to-top characterization parameter	6.0	°C/W
ψ _{JB}	Junction-to-board characterization parameter	32.5	°C/W
R _{θJC(bot)}	Junction-to-case (bottom) thermal resistance	N/A	°C/W

- (1) For more information about traditional and new thermal metrics, see the [Semiconductor and IC Package Thermal Metrics](#) application report.

6.5 Electrical Characteristics

at $T_A = 25^\circ\text{C}$ free-air temperature (unless otherwise noted)

PARAMETER	TEST CONDITIONS	ULN2803A			UNIT
		MIN	TYP	MAX	
I_{CEX} Collector cutoff current	$V_{CE} = 50\text{ V}$, see Figure 3 $I_I = 0$			50	μA
$I_{I(off)}$ Off-state input current	$V_{CE} = 50\text{ V}$, $T_A = 70^\circ\text{C}$ $I_C = 500\ \mu\text{A}$, see Figure 4	50	65		μA
$I_{I(on)}$ Input current	$V_I = 3.85\text{ V}$, see Figure 5		0.93	1.35	mA
$V_{I(on)}$ On-state input voltage	$V_{CE} = 2\text{ V}$, see Figure 6	$I_C = 200\text{ mA}$		2.4	V
		$I_C = 250\text{ mA}$		2.7	
		$I_C = 300\text{ mA}$		3	
$V_{CE(sat)}$ Collector-emitter saturation voltage	$I_I = 250\ \mu\text{A}$, see Figure 7 $I_C = 100\text{ mA}$		0.9	1.1	V
	$I_I = 350\ \mu\text{A}$, see Figure 7 $I_C = 200\text{ mA}$		1	1.3	
	$I_I = 500\ \mu\text{A}$, see Figure 7 $I_C = 350\text{ mA}$		1.3	1.6	
I_R Clamp diode reverse current	$V_R = 50\text{ V}$, see Figure 8			50	μA
V_F Clamp diode forward voltage	$I_F = 350\text{ mA}$ see Figure 9		1.7	2	V
C_i Input capacitance	$V_I = 0$, $f = 1\text{ MHz}$		15	25	pF

6.6 Switching Characteristics

$T_A = 25^\circ\text{C}$

PARAMETER	TEST CONDITIONS	MIN	TYP	MAX	UNIT
t_{PLH} Propagation delay time, low- to high-level output	$V_S = 50\text{ V}$, $C_L = 15\text{ pF}$, $R_L = 163\ \Omega$, See Figure 10		130		ns
t_{PHL} Propagation delay time, high- to low-level output			20		
V_{OH} High-level output voltage after switching	$V_S = 50\text{ V}$, $I_O = 300\text{ mA}$, see Figure 11	$V_S - 20$			mV

6.7 Typical Characteristics

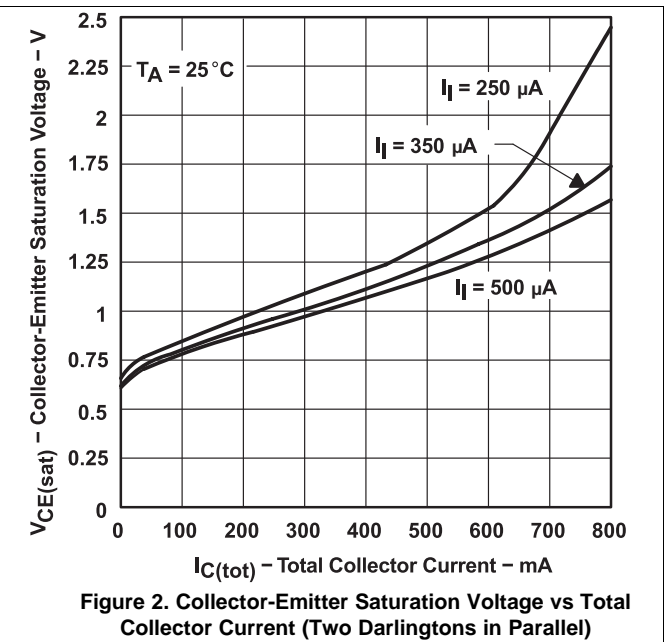
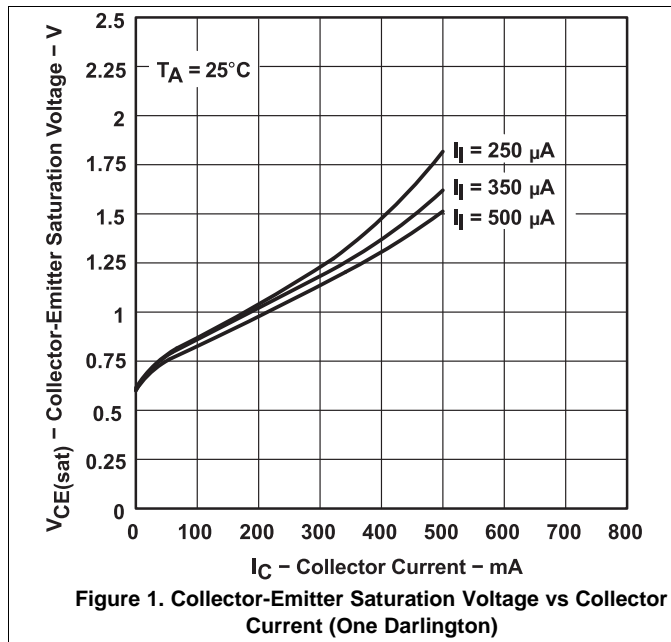

7 Parameter Measurement Information

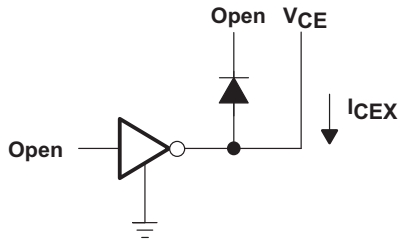

Figure 3. I_{CEX} Test Circuit

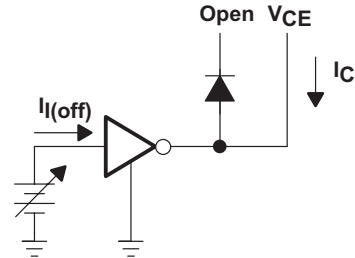

Figure 4. $I_{I(off)}$ Test Circuit

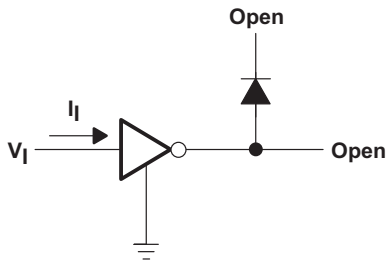

Figure 5. $I_{I(on)}$ Test Circuit

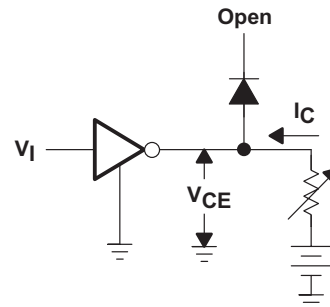

Figure 6. $V_{I(on)}$ Test Circuit

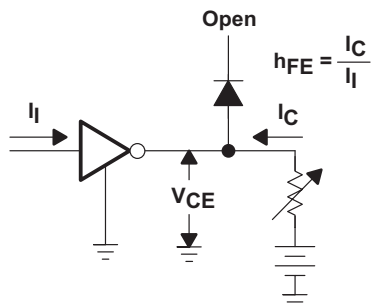

Figure 7. h_{FE} , $V_{CE(sat)}$ Test Circuit

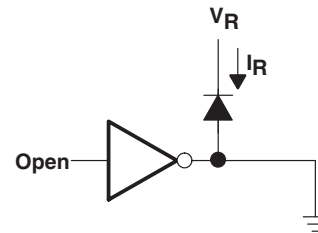

Figure 8. I_R Test Circuit

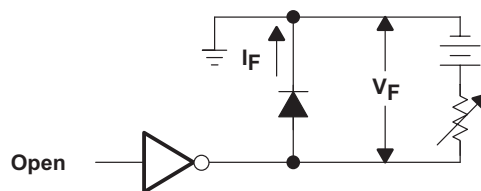
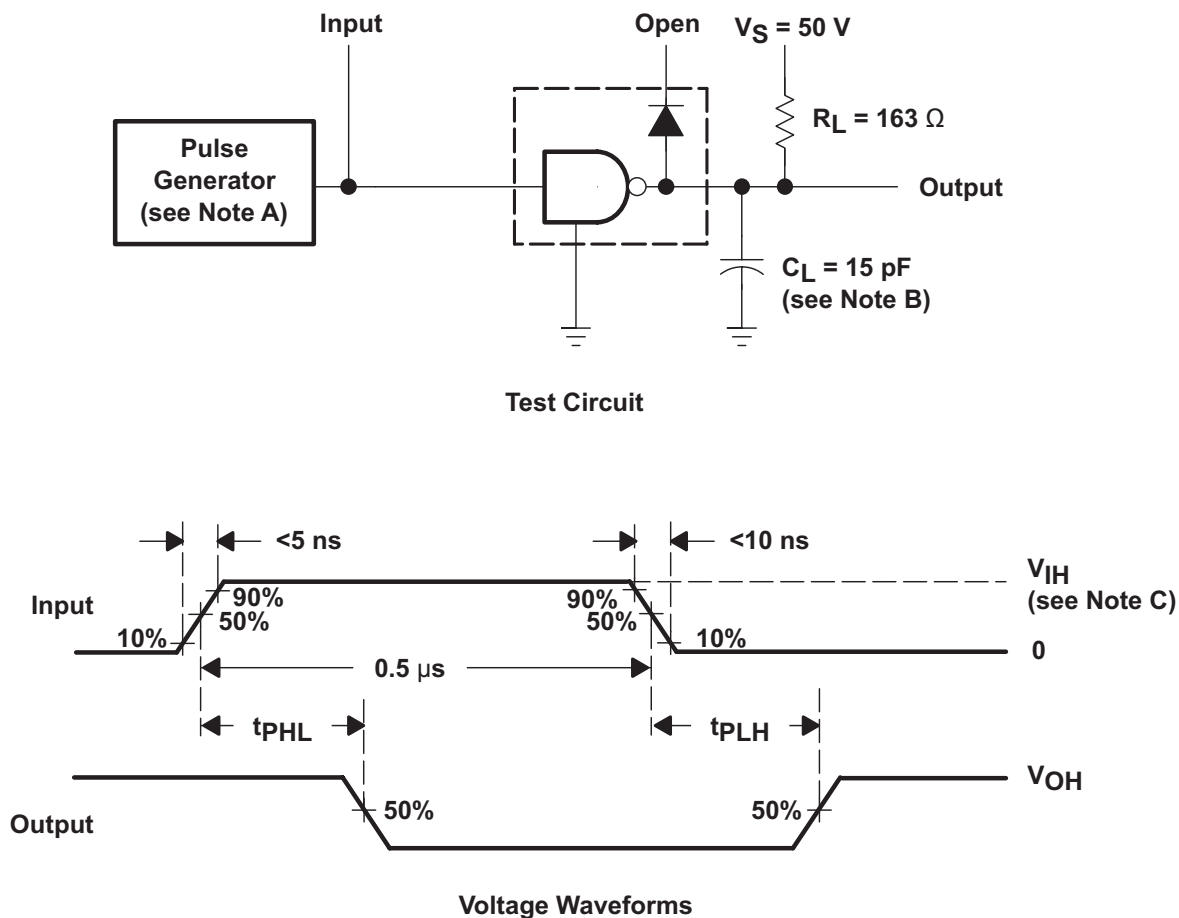

Figure 9. V_F Test Circuit

Parameter Measurement Information (continued)



- A. The pulse generator has the following characteristics: PRR = 12.5 kHz, $Z_O = 50 \Omega$.
- B. C_L includes probe and jig capacitance.
- C. $V_{IH} = 3 \text{ V}$

Figure 10. Propagation Delay Times

Parameter Measurement Information (continued)

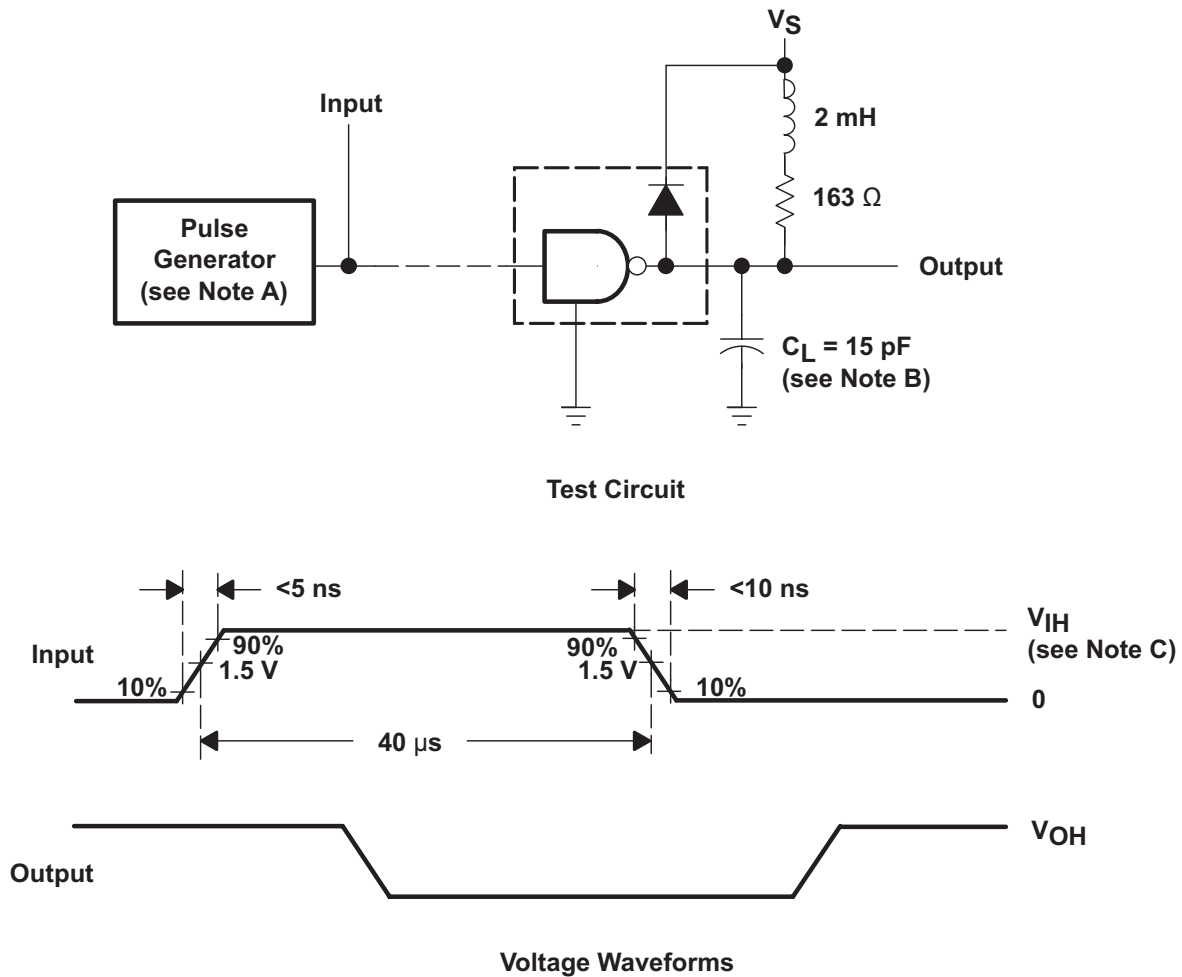

- A. The pulse generator has the following characteristics: PRR = 12.5 kHz, $Z_O = 50 \Omega$.
- B. C_L includes probe and jig capacitance.
- C. $V_{IH} = 3$ V

Figure 11. Latch-Up Test

8 Detailed Description

8.1 Overview

This standard device has proven ubiquity and versatility across a wide range of applications. This is due to its integration of 8 Darlington transistors that are capable of sinking up to 500 mA and wide GPIO range capability.

The ULN2803A is comprised of eight high voltage, high current NPN Darlington transistor pairs. All units feature a common emitter and open collector outputs. To maximize their effectiveness, these units contain suppression diodes for inductive loads. The ULN2803A has a series base resistor to each Darlington pair, thus allowing operation directly with TTL or CMOS operating at supply voltages of 5 V or 3.3 V. The ULN2803A offers solutions to a great many interface needs, including solenoids, relays, lamps, small motors, and LEDs. Applications requiring sink currents beyond the capability of a single output may be accommodated by paralleling the outputs.

8.2 Functional Block Diagram

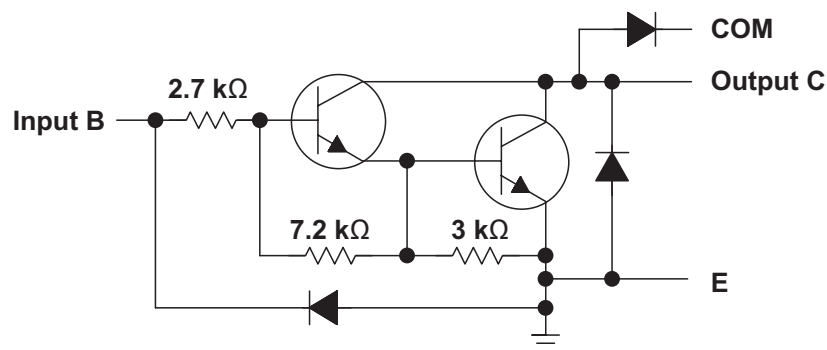

8.3 Feature Description

Each channel of ULN2803A consists of Darlington connected NPN transistors. This connection creates the effect of a single transistor with a very-high current gain. The very high β allows for high output current drive with a very-low input current, essentially equating to operation with low GPIO voltages.

The GPIO voltage is converted to base current through the 2.7-k Ω resistor connected between the input and base of the predriver Darlington NPN.

The diodes connected between the output and COM pin are used to suppress the kick-back voltage from an inductive load that is excited when the NPN drivers are turned off (stop sinking) and the stored energy in the coils causes a reverse current to flow into the coil supply through the kick-back diode.

In normal operation, the diodes on base and collector pins to emitter will be reverse biased. If these diodes are forward biased, internal parasitic NPN transistors will draw (a nearly equal) current from other (nearby) device pins.

8.4 Device Functional Modes

8.4.1 Inductive Load Drive

When the COM pin is tied to the coil supply voltage, ULN2803A is able to drive inductive loads and suppress the kick-back voltage through the internal free wheeling diodes.

8.4.2 Resistive Load Drive

When driving resistive loads, COM can be left unconnected or connected to the load voltage supply. If multiple supplies are used, connect to the highest voltage supply.

9 Application and Implementation

NOTE

Information in the following applications sections is not part of the TI component specification, and TI does not warrant its accuracy or completeness. TI's customers are responsible for determining suitability of components for their purposes. Customers should validate and test their design implementation to confirm system functionality.

9.1 Application Information

ULN2803A will typically be used to drive a high voltage and/or current peripheral from an MCU or logic device that cannot tolerate these conditions. The following design is a common application of ULN2803A, driving inductive loads. This includes motors, solenoids, and relays. Each load type can be modeled by what is seen in [Figure 12](#).

9.2 Typical Application

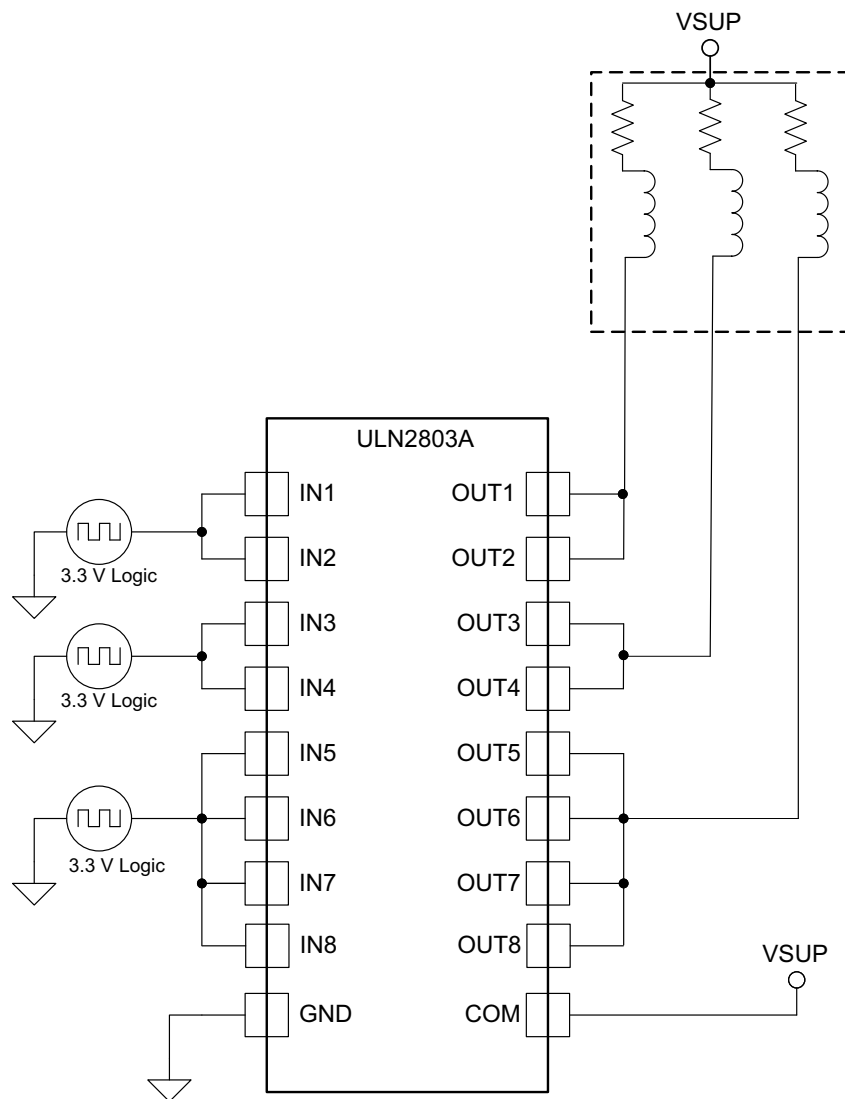

Copyright © 2017, Texas Instruments Incorporated

Figure 12. ULN2803A as Inductive Load Driver

Typical Application (continued)

9.2.1 Design Requirements

For this design example, use the parameters listed in [Table 1](#) as the input parameters.

Table 1. Design Parameters

DESIGN PARAMETER	EXAMPLE VALUE
GPIO voltage	3.3 or 5 V
Coil supply voltage	12 to 50 V
Number of channels	8
Output current (R_{COIL})	20 to 300 mA per channel
Duty cycle	100%

9.2.2 Detailed Design Procedure

When using ULN2803A in a coil driving application, determine the following:

- Input voltage range
- Temperature range
- Output and drive current
- Power dissipation

9.2.2.1 Drive Current

The coil current is determined by the coil voltage (V_{SUP}), coil resistance, and output low voltage (V_{OL} or $V_{CE(SAT)}$).

$$I_{COIL} = (V_{SUP} - V_{CE(SAT)}) / R_{COIL} \quad (1)$$

9.2.2.2 Output Low Voltage

The output low voltage (V_{OL}) is the same thing as $V_{CE(SAT)}$ and can be determined by [Figure 1](#), [Figure 2](#), or [Electrical Characteristics](#).

9.2.2.3 Power Dissipation and Temperature

The number of coils driven is dependent on the coil current and on-chip power dissipation. To determine the number of coils possible, use [Equation 2](#) to calculate ULN2803A on-chip power dissipation P_D .

$$P_D = \sum_{i=1}^N V_{OLi} \times I_{Li}$$

where

- N is the number of channels active together.
- V_{OLi} is the OUT_i pin voltage for the load current I_{Li} . This is the same as $V_{CE(SAT)}$ (2)

To ensure the reliability of ULN2803A and the system, the on-chip power dissipation must be lower than or equal to the maximum allowable power dissipation (P_D) dictated by [Equation 3](#).

$$PD_{(MAX)} = \frac{(T_{J(MAX)} - T_A)}{\theta_{JA}}$$

where

- $T_{J(MAX)}$ is the target maximum junction temperature.
- T_A is the operating ambient temperature.
- θ_{JA} is the package junction to ambient thermal resistance. (3)

TI recommends to limit ULN2803A IC's die junction temperature to <125°C. The IC junction temperature is directly proportional to the on-chip power dissipation.

9.2.3 Application Curves

The following curves were generated with ULN2803A driving an OMRON G5NB relay – $V_{in} = 5.0\text{ V}$; $V_{sup} = 12\text{ V}$ and $R_{COIL} = 2.8\text{ k}\Omega$

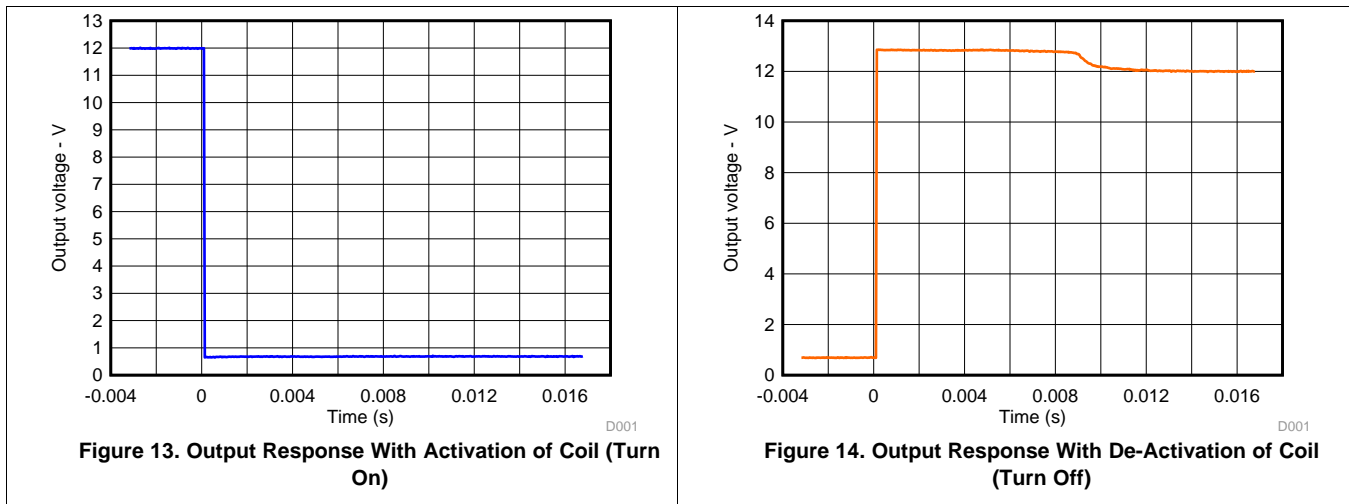

10 Power Supply Recommendations

This part does not need a power supply; however, the COM pin is typically tied to the system power supply. When this is the case, make sure that the output voltage does not heavily exceed the COM pin voltage. This will heavily forward bias the flyback diodes and cause a large current to flow into COM, potentially damaging the on-chip metal or overheating the part.

11 Layout

11.1 Layout Guidelines

Thin traces can be used on the input due to the low current logic that is typically used to drive ULN2803A. Take care to separate the input channels as much as possible, as to eliminate crosstalk. TI recommends thick traces for the output, in order to drive high currents as desired. Wire thickness can be determined by the trace material's current density and desired drive current.

Because all of the channels currents return to a common emitter, it is best to size that trace width to be very wide. Some applications require up to 2.5 A.

11.2 Layout Example

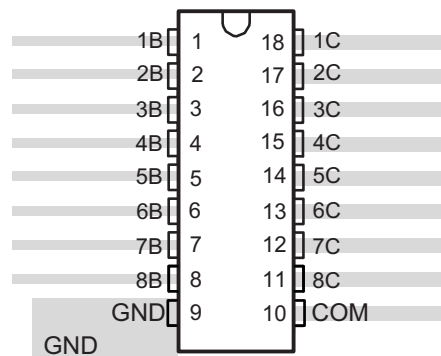

Figure 15. Package Layout

12 Device and Documentation Support

12.1 Receiving Notification of Documentation Updates

To receive notification of documentation updates, navigate to the device product folder on ti.com. In the upper right corner, click on *Alert me* to register and receive a weekly digest of any product information that has changed. For change details, review the revision history included in any revised document.

12.2 Community Resources

The following links connect to TI community resources. Linked contents are provided "AS IS" by the respective contributors. They do not constitute TI specifications and do not necessarily reflect TI's views; see TI's [Terms of Use](#).

TI E2E™ Online Community *TI's Engineer-to-Engineer (E2E) Community*. Created to foster collaboration among engineers. At e2e.ti.com, you can ask questions, share knowledge, explore ideas and help solve problems with fellow engineers.

Design Support *TI's Design Support* Quickly find helpful E2E forums along with design support tools and contact information for technical support.

12.3 Trademarks

E2E is a trademark of Texas Instruments.
All other trademarks are the property of their respective owners.

12.4 Electrostatic Discharge Caution



This integrated circuit can be damaged by ESD. Texas Instruments recommends that all integrated circuits be handled with appropriate precautions. Failure to observe proper handling and installation procedures can cause damage.

ESD damage can range from subtle performance degradation to complete device failure. Precision integrated circuits may be more susceptible to damage because very small parametric changes could cause the device not to meet its published specifications.

12.5 Glossary

[SLYZ022](#) — *TI Glossary*.

This glossary lists and explains terms, acronyms, and definitions.

13 Mechanical, Packaging, and Orderable Information

The following pages include mechanical, packaging, and orderable information. This information is the most current data available for the designated devices. This data is subject to change without notice and revision of this document. For browser-based versions of this data sheet, refer to the left-hand navigation.

PACKAGING INFORMATION

Orderable Device	Status (1)	Package Type	Package Drawing	Pins	Package Qty	Eco Plan (2)	Lead/Ball Finish (6)	MSL Peak Temp (3)	Op Temp (°C)	Device Marking (4/5)	Samples
ULN2803ADW	ACTIVE	SOIC	DW	18	40	Green (RoHS & no Sb/Br)	CU NIPDAU	Level-2-260C-1 YEAR	-40 to 85	ULN2803A	Samples
ULN2803ADWG4	ACTIVE	SOIC	DW	18	40	Green (RoHS & no Sb/Br)	CU NIPDAU	Level-2-260C-1 YEAR	-40 to 85	ULN2803A	Samples
ULN2803ADWR	ACTIVE	SOIC	DW	18	2000	Green (RoHS & no Sb/Br)	CU NIPDAU	Level-2-260C-1 YEAR	-40 to 85	ULN2803A	Samples
ULN2803ADWRG4	ACTIVE	SOIC	DW	18	2000	Green (RoHS & no Sb/Br)	CU NIPDAU	Level-2-260C-1 YEAR	-40 to 85	ULN2803A	Samples

(1) The marketing status values are defined as follows:

ACTIVE: Product device recommended for new designs.

LIFEBUY: TI has announced that the device will be discontinued, and a lifetime-buy period is in effect.

NRND: Not recommended for new designs. Device is in production to support existing customers, but TI does not recommend using this part in a new design.

PREVIEW: Device has been announced but is not in production. Samples may or may not be available.

OBSELETE: TI has discontinued the production of the device.

(2) Eco Plan - The planned eco-friendly classification: Pb-Free (RoHS), Pb-Free (RoHS Exempt), or Green (RoHS & no Sb/Br) - please check <http://www.ti.com/productcontent> for the latest availability information and additional product content details.

TBD: The Pb-Free/Green conversion plan has not been defined.

Pb-Free (RoHS): TI's terms "Lead-Free" or "Pb-Free" mean semiconductor products that are compatible with the current RoHS requirements for all 6 substances, including the requirement that lead not exceed 0.1% by weight in homogeneous materials. Where designed to be soldered at high temperatures, TI Pb-Free products are suitable for use in specified lead-free processes.

Pb-Free (RoHS Exempt): This component has a RoHS exemption for either 1) lead-based flip-chip solder bumps used between the die and package, or 2) lead-based die adhesive used between the die and leadframe. The component is otherwise considered Pb-Free (RoHS compatible) as defined above.

Green (RoHS & no Sb/Br): TI defines "Green" to mean Pb-Free (RoHS compatible), and free of Bromine (Br) and Antimony (Sb) based flame retardants (Br or Sb do not exceed 0.1% by weight in homogeneous material)

(3) MSL, Peak Temp. - The Moisture Sensitivity Level rating according to the JEDEC industry standard classifications, and peak solder temperature.

(4) There may be additional marking, which relates to the logo, the lot trace code information, or the environmental category on the device.

(5) Multiple Device Markings will be inside parentheses. Only one Device Marking contained in parentheses and separated by a "~" will appear on a device. If a line is indented then it is a continuation of the previous line and the two combined represent the entire Device Marking for that device.

(6) Lead/Ball Finish - Orderable Devices may have multiple material finish options. Finish options are separated by a vertical ruled line. Lead/Ball Finish values may wrap to two lines if the finish value exceeds the maximum column width.

Important Information and Disclaimer: The information provided on this page represents TI's knowledge and belief as of the date that it is provided. TI bases its knowledge and belief on information provided by third parties, and makes no representation or warranty as to the accuracy of such information. Efforts are underway to better integrate information from third parties. TI has taken and continues to take reasonable steps to provide representative and accurate information but may not have conducted destructive testing or chemical analysis on incoming materials and chemicals. TI and TI suppliers consider certain information to be proprietary, and thus CAS numbers and other limited information may not be available for release.

In no event shall TI's liability arising out of such information exceed the total purchase price of the TI part(s) at issue in this document sold by TI to Customer on an annual basis.

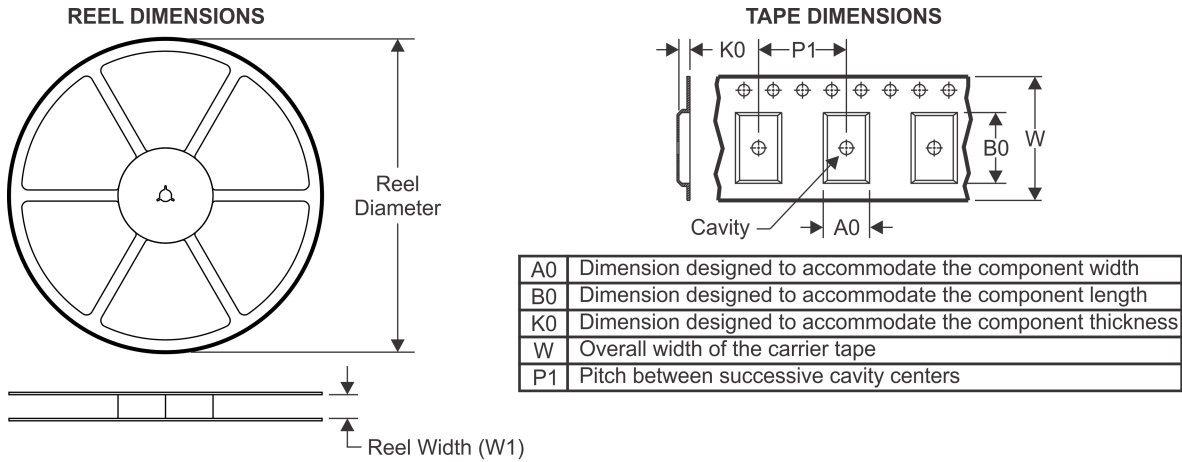
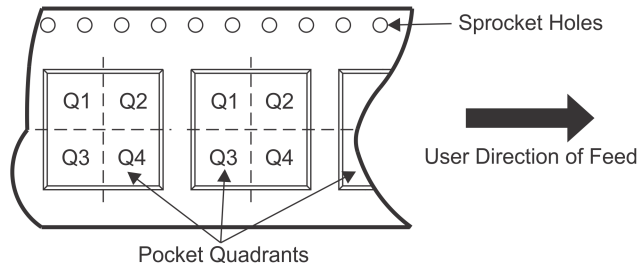
TAPE AND REEL INFORMATION

QUADRANT ASSIGNMENTS FOR PIN 1 ORIENTATION IN TAPE

*All dimensions are nominal

Device	Package Type	Package Drawing	Pins	SPQ	Reel Diameter (mm)	Reel Width W1 (mm)	A0 (mm)	B0 (mm)	K0 (mm)	P1 (mm)	W (mm)	Pin1 Quadrant
ULN2803ADWR	SOIC	DW	18	2000	330.0	24.4	10.9	12.0	2.7	12.0	24.0	Q1

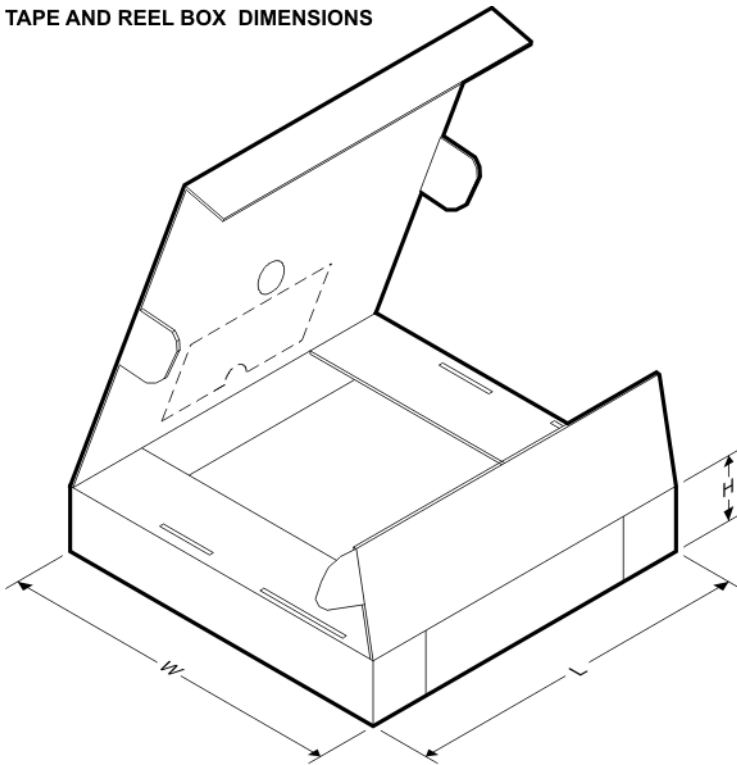
TAPE AND REEL BOX DIMENSIONS



*All dimensions are nominal

Device	Package Type	Package Drawing	Pins	SPQ	Length (mm)	Width (mm)	Height (mm)
ULN2803ADWR	SOIC	DW	18	2000	370.0	355.0	55.0

N (R-PDIP-T**)

PLASTIC DUAL-IN-LINE PACKAGE

16 PINS SHOWN



- NOTES:
- A. All linear dimensions are in inches (millimeters).
 - B. This drawing is subject to change without notice.
 - Falls within JEDEC MS-001, except 18 and 20 pin minimum body length (Dim A).
 - The 20 pin end lead shoulder width is a vendor option, either half or full width.

DW (R-PDSO-G18)

PLASTIC SMALL OUTLINE

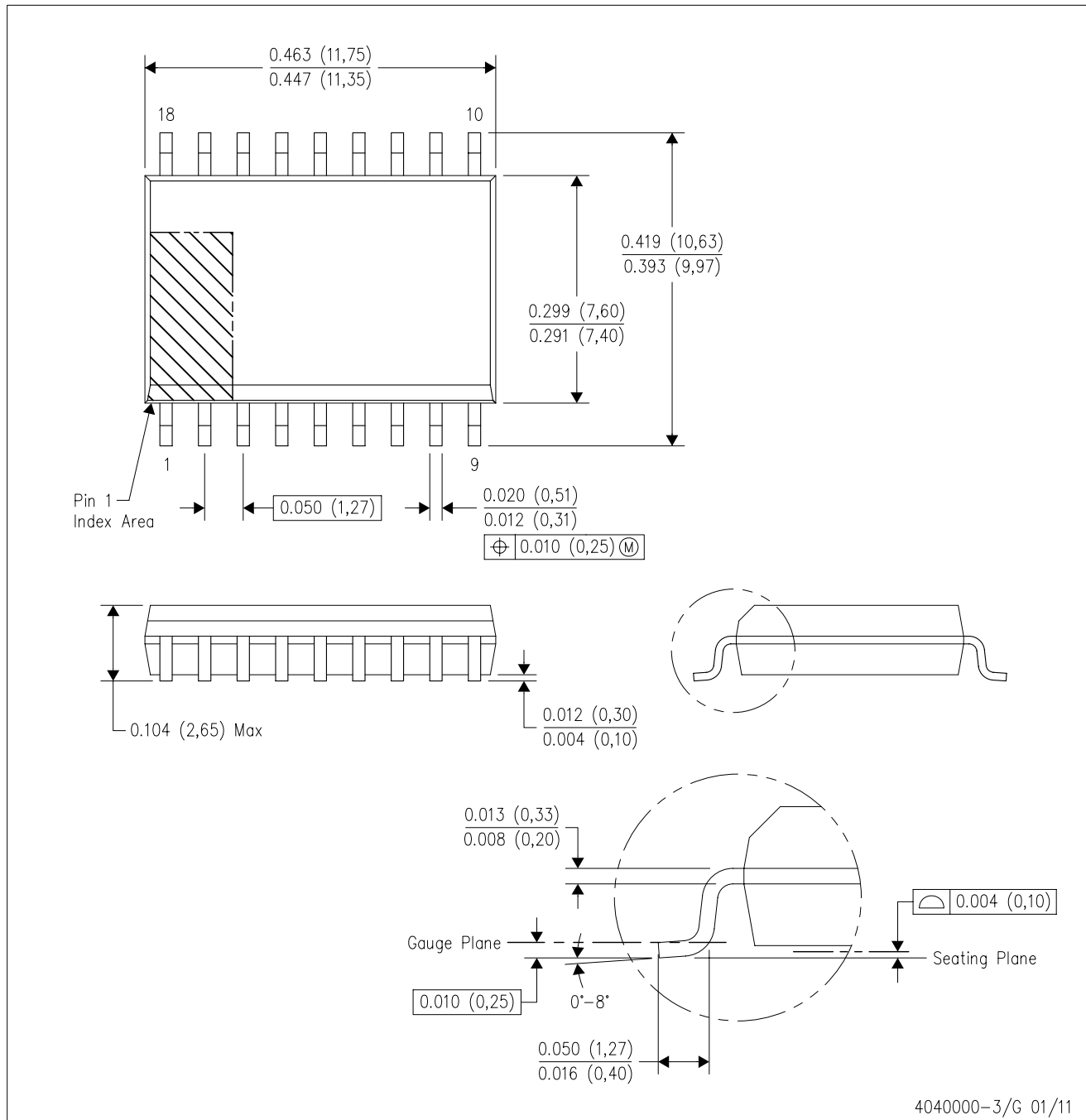

- NOTES:
- A. All linear dimensions are in inches (millimeters). Dimensioning and tolerancing per ASME Y14.5M-1994.
 - B. This drawing is subject to change without notice.
 - C. Body dimensions do not include mold flash or protrusion not to exceed 0.006 (0,15).
 - D. Falls within JEDEC MS-013 variation AB.

DW (R-PDSO-G18)

PLASTIC SMALL OUTLINE

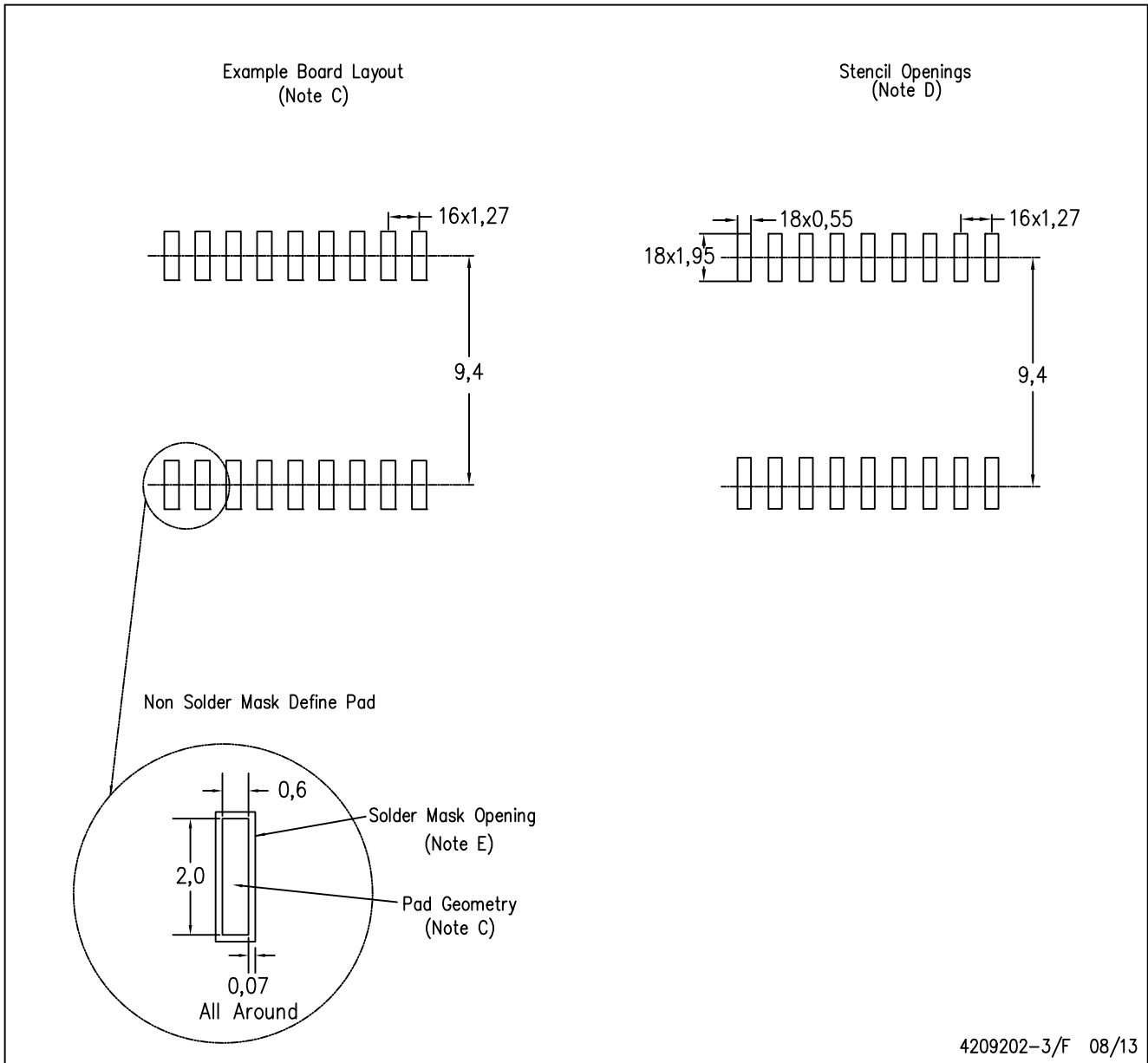

4209202-3/F 08/13

- NOTES:
- A. All linear dimensions are in millimeters.
 - B. This drawing is subject to change without notice.
 - C. Refer to IPC7351 for alternate board design.
 - D. Laser cutting apertures with trapezoidal walls and also rounding corners will offer better paste release. Customers should contact their board assembly site for stencil design recommendations. Refer to IPC-7525
 - E. Customers should contact their board fabrication site for solder mask tolerances between and around signal pads.

IMPORTANT NOTICE AND DISCLAIMER

TI PROVIDES TECHNICAL AND RELIABILITY DATA (INCLUDING DATASHEETS), DESIGN RESOURCES (INCLUDING REFERENCE DESIGNS), APPLICATION OR OTHER DESIGN ADVICE, WEB TOOLS, SAFETY INFORMATION, AND OTHER RESOURCES "AS IS" AND WITH ALL FAULTS, AND DISCLAIMS ALL WARRANTIES, EXPRESS AND IMPLIED, INCLUDING WITHOUT LIMITATION ANY IMPLIED WARRANTIES OF MERCHANTABILITY, FITNESS FOR A PARTICULAR PURPOSE OR NON-INFRINGEMENT OF THIRD PARTY INTELLECTUAL PROPERTY RIGHTS.

These resources are intended for skilled developers designing with TI products. You are solely responsible for (1) selecting the appropriate TI products for your application, (2) designing, validating and testing your application, and (3) ensuring your application meets applicable standards, and any other safety, security, or other requirements. These resources are subject to change without notice. TI grants you permission to use these resources only for development of an application that uses the TI products described in the resource. Other reproduction and display of these resources is prohibited. No license is granted to any other TI intellectual property right or to any third party intellectual property right. TI disclaims responsibility for, and you will fully indemnify TI and its representatives against, any claims, damages, costs, losses, and liabilities arising out of your use of these resources.

TI's products are provided subject to TI's Terms of Sale (www.ti.com/legal/termsofsale.html) or other applicable terms available either on ti.com or provided in conjunction with such TI products. TI's provision of these resources does not expand or otherwise alter TI's applicable warranties or warranty disclaimers for TI products.

Mailing Address: Texas Instruments, Post Office Box 655303, Dallas, Texas 75265
Copyright © 2019, Texas Instruments Incorporated

Looking for pricing, stock, or lifecycle information?

Click below to explore more details on WIN SOURCE:

 [View ULN2803ADWRG4 on WIN SOURCE](#)

 [Texas Instruments](#) Information

Optimize Your Supply Chain with WIN SOURCE Solutions

-  Global Sourcing Solution
-  Obsolete Management
-  Cost Control Management
-  Shortage Management
-  Alternative Solution
-  Excess Inventory Management