



**THE DATASHEET OF  
ADG3300BRUZ**



### FEATURES

**Bidirectional level translation**  
**Operates from 1.15 V to 5.5 V**  
**Low quiescent current <math><1 \mu\text{A}</math>**  
**No direction pin**

### APPLICATIONS

**Low voltage ASIC level translation**  
**Smart card readers**  
**Cell phones and cell phone cradles**  
**Portable communications devices**  
**Telecommunications equipment**  
**Network switches and routers**  
**Storage systems (SAN/NAS)**  
**Computing/server applications**  
**GPS**  
**Portable POS systems**  
**Low cost serial interfaces**

### GENERAL DESCRIPTION

The ADG3300 is a bidirectional logic level translator that contains eight bidirectional channels. It can be used in multivoltage digital system applications such as data transfer between a low voltage DSP/controller and a higher voltage device. The internal architecture allows the device to perform bidirectional logic level translation without an additional signal to set the direction of the translation.

The voltage applied to  $V_{CCA}$  sets the logic levels on the A side of the device, while  $V_{CCY}$  sets the levels on the Y side. For proper operation,  $V_{CCA}$  must always be less than  $V_{CCY}$ . The  $V_{CCA}$ -compatible logic signals applied to the A side of the device appear as  $V_{CCY}$ -compatible levels on the Y side. Similarly,  $V_{CCY}$ -compatible logic levels applied to the Y side of the device appear as  $V_{CCA}$ -compatible logic levels on the A side.

The enable pin provides three-state operation of the Y side pins. When the enable pin (EN) is pulled low, the A1 to A8 pins are

### FUNCTIONAL BLOCK DIAGRAM

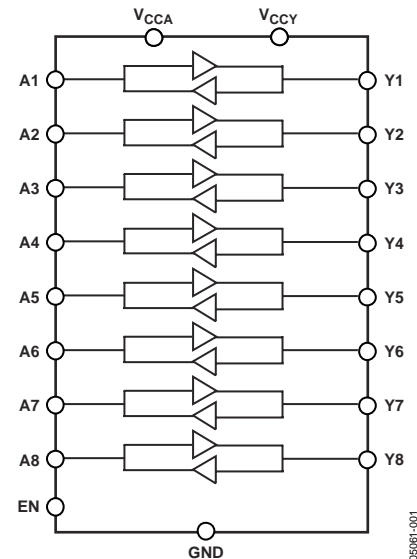

Figure 1.

internally pulled down by 6 k $\Omega$  resistors, while the Y terminals are in the high impedance state. The EN pin is referred to  $V_{CCA}$  supply voltage and driven high for normal operation.

The ADG3300 is available in a compact 20-lead TSSOP package, and it is guaranteed to operate over the 1.15 V to 5.5 V supply voltage range and extended  $-40^{\circ}\text{C}$  to  $+85^{\circ}\text{C}$  temperature range.

### PRODUCT HIGHLIGHTS

1. Bidirectional level translation.
2. Fully guaranteed over the 1.15 V to 5.5 V supply range.
3. No direction pin.
4. 20-lead TSSOP package.

### Rev. 0

Information furnished by Analog Devices is believed to be accurate and reliable. However, no responsibility is assumed by Analog Devices for its use, nor for any infringements of patents or other rights of third parties that may result from its use. Specifications subject to change without notice. No license is granted by implication or otherwise under any patent or patent rights of Analog Devices. Trademarks and registered trademarks are the property of their respective owners.

# TABLE OF CONTENTS

Specifications.....	3	Input Driving Requirements.....	15
Absolute Maximum Ratings.....	6	Output Load Requirements .....	15
ESD Caution.....	6	Enable Operation .....	15
Pin Configuration and Function Descriptions.....	7	Power Supplies.....	15
Typical Performance Characteristics .....	8	Data Rate .....	16
Test Circuits.....	12	Applications.....	17
Terminology .....	14	Layout Guidelines.....	17
Theory of Operation .....	15	Outline Dimensions .....	18
Level Translator Architecture.....	15	Ordering Guide .....	18

## REVISION HISTORY

4/05—Revision 0: Initial Version

## SPECIFICATIONS<sup>1</sup>

$V_{CCY} = 1.65\text{ V to }5.5\text{ V}$ ,  $V_{CCA} = 1.15\text{ V to }V_{CCY}$ ,  $GND = 0\text{ V}$ . All specifications  $T_{MIN}$  to  $T_{MAX}$ , unless otherwise noted.

**Table 1.**

Parameter	Symbol	Conditions	Min	Typ <sup>2</sup>	Max	Unit
<b>LOGIC INPUTS/OUTPUTS</b>						
<b>A Side</b>						
Input High Voltage <sup>3</sup>	$V_{IHA}$	$V_{CCA} = 1.15\text{ V}$	$V_{CCA} - 0.3$			V
	$V_{IHA}$	$V_{CCA} = 1.2\text{ V to }5.5\text{ V}$	$V_{CCA} - 0.4$			V
Input Low Voltage <sup>3</sup>	$V_{ILA}$				0.4	V
Output High Voltage	$V_{OHA}$	$V_Y = V_{CCY}$ , $I_{OH} = 20\text{ }\mu\text{A}$ , Figure 27	$V_{CCA} - 0.4$			V
Output Low Voltage	$V_{OLA}$	$V_Y = 0\text{ V}$ , $I_{OL} = 20\text{ }\mu\text{A}$ , Figure 27			0.4	V
Three-State Pull-Down Resistance	$R_{A,HIZ}$	$EN = 0$	4.2	6	8.4	k $\Omega$
<b>Y Side</b>						
Input Low Voltage <sup>3</sup>	$V_{IHY}$		$V_{CCY} - 0.4$			V
Input High Voltage <sup>3</sup>	$V_{ILY}$				0.4	V
Output High Voltage	$V_{OHY}$	$V_A = V_{CCA}$ , $I_{OH} = 20\text{ }\mu\text{A}$ , Figure 28	$V_{CCY} - 0.4$			V
Output Low Voltage	$V_{OLY}$	$V_A = 0\text{ V}$ , $I_{OL} = 20\text{ }\mu\text{A}$ , Figure 28			0.4	V
Capacitance <sup>3</sup>	$C_Y$	$f = 1\text{ MHz}$ , $EN = 0$ , Figure 31		6		pF
Leakage Current	$I_{LY,HIZ}$	$V_Y = 0\text{ V}/V_{CCY}$ , $EN = 0$ , Figure 29			$\pm 1$	$\mu\text{A}$
<b>Enable (EN)</b>						
Input High Voltage <sup>3</sup>	$V_{IHEN}$	$V_{CCA} = 1.15\text{ V}$	$V_{CCA} - 0.3$			V
	$V_{IHEN}$	$V_{CCA} = 1.2\text{ V to }5.5\text{ V}$	$V_{CCA} - 0.4$			V
Input Low Voltage <sup>3</sup>	$V_{ILEN}$				0.4	V
Leakage Current	$I_{LEN}$	$V_{EN} = 0\text{ V}/V_{CCA}$ , $V_A = 0\text{ V}$ , Figure 30			$\pm 1$	$\mu\text{A}$
Capacitance <sup>3</sup>	$C_{EN}$			3		pF
Enable Time <sup>3</sup>	$t_{EN}$	$R_S = R_T = 50\text{ }\Omega$ , $V_A = 0\text{ V}/V_{CCA}$ (A Y), Figure 32		1	1.8	$\mu\text{s}$
<b>SWITCHING CHARACTERISTICS<sup>3</sup></b>						
$3.3\text{ V} \pm 0.3\text{ V} \leq V_{CCA} \leq V_{CCY}$ , $V_{CCY} = 5\text{ V} \pm 0.5\text{ V}$						
<b>A Y Level Translation</b>						
Propagation Delay	$t_{P,A-Y}$	$R_S = R_T = 50\text{ }\Omega$ , $C_L = 50\text{ pF}$ , Figure 33		6	10	ns
Rise Time	$t_{R,A-Y}$			2	3.5	ns
Fall Time	$t_{F,A-Y}$			2	3.5	ns
Maximum Data Rate	$D_{MAX,A-Y}$		50			Mbps
Channel-to-Channel Skew	$t_{SKEW,A-Y}$			2	4	ns
Part-to-Part Skew	$t_{PPSKEW,A-Y}$				3	ns
<b>Y A Level Translation</b>						
Propagation Delay	$t_{P,Y-A}$	$R_S = R_T = 50\text{ }\Omega$ , $C_L = 15\text{ pF}$ , Figure 34		4	7	ns
Rise Time	$t_{R,Y-A}$			1	3	ns
Fall Time	$t_{F,Y-A}$			3	7	ns
Maximum Data Rate	$D_{MAX,Y-A}$		50			Mbps
Channel-to-Channel Skew	$t_{SKEW,Y-A}$			2	3.5	ns
Part-to-Part Skew	$t_{PPSKEW,Y-A}$				2	ns
$1.8\text{ V} \pm 0.15\text{ V} \leq V_{CCA} \leq V_{CCY}$ , $V_{CCY} = 3.3\text{ V} \pm 0.3\text{ V}$						
<b>A Y Translation</b>						
Propagation Delay	$t_{P,A-Y}$	$R_S = R_T = 50\text{ }\Omega$ , $C_L = 50\text{ pF}$ , Figure 33		8	11	ns
Rise Time	$t_{R,A-Y}$			2	5	ns
Fall Time	$t_{F,A-Y}$			2	5	ns
Maximum Data Rate	$D_{MAX,A-Y}$		50			Mbps
Channel-to-Channel Skew	$t_{SKEW,A-Y}$			2	4	ns
Part-to-Part Skew	$t_{PPSKEW,A-Y}$				4	ns

# ADG3300

Parameter	Symbol	Conditions	Min	Typ <sup>2</sup>	Max	Unit
Y A Translation		$R_S = R_T = 50 \Omega, C_L = 15 \text{ pF}$ , Figure 34				
Propagation Delay	$t_{P, Y-A}$			5	8	ns
Rise Time	$t_{R, Y-A}$			2	3.5	ns
Fall Time	$t_{F, Y-A}$			2	3.5	ns
Maximum Data Rate	$D_{MAX, Y-A}$		50			Mbps
Channel-to-Channel Skew	$t_{SKEW, Y-A}$			2	3	ns
Part-to-Part Skew	$t_{PPSKEW, Y-A}$				3	ns
1.15 V to 1.3 V $\leq V_{CCA} \leq V_{CCY}, V_{CCY} = 3.3 \text{ V} \pm 0.3 \text{ V}$						
A Y Translation		$R_S = R_T = 50 \Omega, C_L = 50 \text{ pF}$ , Figure 33				
Propagation Delay	$t_{P, A-Y}$			9	18	ns
Rise Time	$t_{R, A-Y}$			3	5	ns
Fall Time	$t_{F, A-Y}$			2	5	ns
Maximum Data Rate	$D_{MAX, A-Y}$		40			Mbps
Channel-to-Channel Skew	$t_{SKEW, A-Y}$			2	5	ns
Part-to-Part Skew	$t_{PPSKEW, A-Y}$				10	ns
Y A Translation		$R_S = R_T = 50 \Omega, C_L = 15 \text{ pF}$ , Figure 34				
Propagation Delay	$t_{P, Y-A}$			5	9	ns
Rise Time	$t_{R, Y-A}$			2	4	ns
Fall Time	$t_{F, Y-A}$			2	4	ns
Maximum Data Rate	$D_{MAX, Y-A}$		40			Mbps
Channel-to-Channel Skew	$t_{SKEW, Y-A}$			2	4	ns
Part-to-Part Skew	$t_{PPSKEW, Y-A}$				4	ns
1.15 V to 1.3 V $\leq V_{CCA} \leq V_{CCY}, V_{CCY} = 1.8 \text{ V} \pm 0.3 \text{ V}$						
A Y Translation		$R_S = R_T = 50 \Omega, C_L = 50 \text{ pF}$ , Figure 33				
Propagation Delay	$t_{P, A-Y}$			12	25	ns
Rise Time	$t_{R, A-Y}$			7	12	ns
Fall Time	$t_{F, A-Y}$			3	5	ns
Maximum Data Rate	$D_{MAX, A-Y}$		25			Mbps
Channel-to-Channel Skew	$t_{SKEW, A-Y}$			2	5	ns
Part-to-Part Skew	$t_{PPSKEW, A-Y}$				15	ns
Y A Translation		$R_S = R_T = 50 \Omega, C_L = 15 \text{ pF}$ , Figure 34				
Propagation Delay	$t_{P, Y-A}$			14	35	ns
Rise Time	$t_{R, Y-A}$			5	16	ns
Fall Time	$t_{F, Y-A}$			2.5	6.5	ns
Maximum Data Rate	$D_{MAX, Y-A}$		25			Mbps
Channel-to-Channel Skew	$t_{SKEW, Y-A}$			3	6.5	ns
Part-to-Part Skew	$t_{PPSKEW, Y-A}$				23.5	ns
2.5 V $\pm 0.2 \text{ V} \leq V_{CCA} \leq V_{CCY}, V_{CCY} = 3.3 \text{ V} \pm 0.3 \text{ V}$						
A Y Translation		$R_S = R_T = 50 \Omega, C_L = 50 \text{ pF}$ , Figure 33				
Propagation Delay	$t_{P, A-Y}$			7	10	ns
Rise Time	$t_{R, A-Y}$			2.5	4	ns
Fall Time	$t_{F, A-Y}$			2	5	ns
Maximum Data Rate	$D_{MAX, A-Y}$		60			Mbps
Channel-to-Channel Skew	$t_{SKEW, A-Y}$			1.5	2	ns
Part-to-Part Skew	$t_{PPSKEW, A-Y}$				4	ns
Y A Translation		$R_S = R_T = 50 \Omega, C_L = 15 \text{ pF}$ , Figure 34				
Propagation Delay	$t_{P, Y-A}$			5	8	ns
Rise Time	$t_{R, Y-A}$			1	4	ns
Fall Time	$t_{F, Y-A}$			3	5	ns
Maximum Data Rate	$D_{MAX, Y-A}$		60			Mbps
Channel-to-Channel Skew	$t_{SKEW, Y-A}$			2	3	ns
Part-to-Part Skew	$t_{PPSKEW, Y-A}$				3	ns

Parameter	Symbol	Conditions	Min	Typ <sup>2</sup>	Max	Unit
POWER REQUIREMENTS						
Power Supply Voltages	$V_{CCA}$	$V_{CCA} \leq V_{CCY}$	1.15		5.5	V
	$V_{CCY}$		1.65		5.5	V
Quiescent Power Supply Current	$I_{CCA}$	$V_A = 0 \text{ V}/V_{CCA}, V_Y = 0 \text{ V}/V_{CCY},$ $V_{CCA} = V_{CCY} = 5.5 \text{ V}, EN = 1$		0.17	5	$\mu\text{A}$
	$I_{CCY}$	$V_A = 0 \text{ V}/V_{CCA}, V_Y = 0 \text{ V}/V_{CCY},$ $V_{CCA} = V_{CCY} = 5.5 \text{ V}, EN = 1$		0.27	5	$\mu\text{A}$
Three-State Mode Power Supply Current	$I_{HIZA}$	$V_{CCA} = V_{CCY} = 5.5 \text{ V}, EN = 0$		0.1	5	$\mu\text{A}$
	$I_{HIZY}$	$V_{CCA} = V_{CCY} = 5.5 \text{ V}, EN = 0$		0.1	5	$\mu\text{A}$

<sup>1</sup> Temperature range is as follows: B version:  $-40^\circ\text{C}$  to  $+85^\circ\text{C}$ .

<sup>2</sup> All typical values are at  $T_A = 25^\circ\text{C}$ , unless otherwise noted.

<sup>3</sup> Guaranteed by design; not subject to production test.

## ABSOLUTE MAXIMUM RATINGS

T<sub>A</sub> = 25°C, unless otherwise noted.

Table 2.

Parameter	Rating
V <sub>CCA</sub> to GND	−0.3 V to +7 V
V <sub>CCY</sub> to GND	V <sub>CCA</sub> to +7 V
Digital Inputs (A)	−0.3 V to (V <sub>CCA</sub> + 0.3 V)
Digital Inputs (Y)	−0.3 V to (V <sub>CCY</sub> + 0.3 V)
EN to GND	−0.3 V to +7 V
Operating Temperature Range	
Industrial (B Version)	−40°C to +85°C
Storage Temperature Range	−65°C to +150°C
Junction Temperature	150°C
θ <sub>JA</sub> Thermal Impedance (4-Layer Board)	
20-Lead TSSOP	78°C/W
Lead Temperature, Soldering (10 sec)	300°C
IR Reflow, Peak Temperature (<20 sec)	260°C

Stresses above those listed under Absolute Maximum Ratings may cause permanent damage to the device. This is a stress rating only; functional operation of the device at these or any other conditions above those listed in the operational sections of this specification is not implied. Exposure to absolute maximum rating conditions for extended periods may affect device reliability. Only one absolute maximum rating may be applied at any one time.

## ESD CAUTION

ESD (electrostatic discharge) sensitive device. Electrostatic charges as high as 4000 V readily accumulate on the human body and test equipment and can discharge without detection. Although this product features proprietary ESD protection circuitry, permanent damage may occur on devices subjected to high energy electrostatic discharges. Therefore, proper ESD precautions are recommended to avoid performance degradation or loss of functionality.



## PIN CONFIGURATION AND FUNCTION DESCRIPTIONS

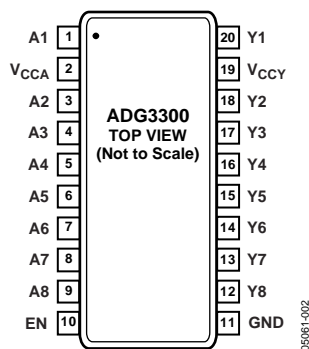

Figure 2. Pin Configuration

Table 3. Pin Function Descriptions

Pin. No.	Mnemonic	Description
1	A1	Input/Output A1. Referenced to $V_{CCA}$ .
2	$V_{CCA}$	Power Supply Voltage Input for the A1 to A8 I/O pins ( $1.15\text{ V} \leq V_{CCA} < V_{CCY}$ ).
3	A2	Input/Output A2. Referenced to $V_{CCA}$ .
4	A3	Input/Output A3. Referenced to $V_{CCA}$ .
5	A4	Input/Output A4. Referenced to $V_{CCA}$ .
6	A5	Input/Output A5. Referenced to $V_{CCA}$ .
7	A6	Input/Output A6. Referenced to $V_{CCA}$ .
8	A7	Input/Output A7. Referenced to $V_{CCA}$ .
9	A8	Input/Output A8. Referenced to $V_{CCA}$ .
10	EN	Active High Enable Input.
11	GND	Ground.
12	Y8	Input/Output Y8. Referenced to $V_{CCY}$ .
13	Y7	Input/Output Y7. Referenced to $V_{CCY}$ .
14	Y6	Input/Output Y6. Referenced to $V_{CCY}$ .
15	Y5	Input/Output Y5. Referenced to $V_{CCY}$ .
16	Y4	Input/Output Y4. Referenced to $V_{CCY}$ .
17	Y3	Input/Output Y3. Referenced to $V_{CCY}$ .
18	Y2	Input/Output Y2. Referenced to $V_{CCY}$ .
19	$V_{CCY}$	Power Supply Voltage Input for the Y1 to Y8 I/O pins ( $1.65\text{ V} \leq V_{CCY} \leq 5.5\text{ V}$ ).
20	Y1	Input/Output Y1. Referenced to $V_{CCY}$ .

## TYPICAL PERFORMANCE CHARACTERISTICS

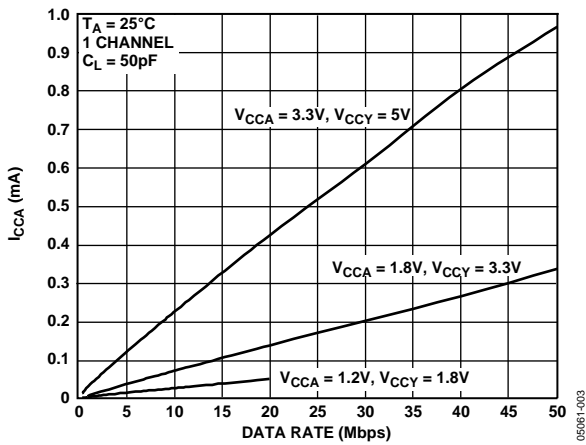

Figure 3.  $I_{CCA}$  vs. Data Rate (A Y Level Translation)

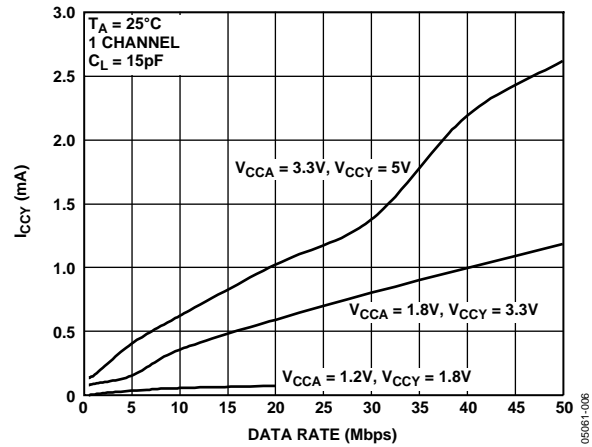

Figure 6.  $I_{CCY}$  vs. Data Rate (Y A Level Translation)

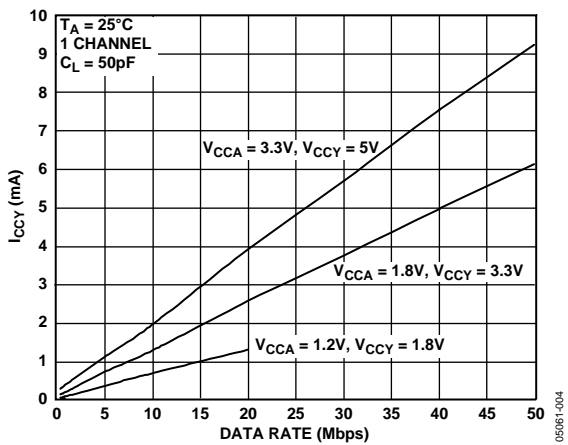

Figure 4.  $I_{CCY}$  vs. Data Rate (A Y Level Translation)

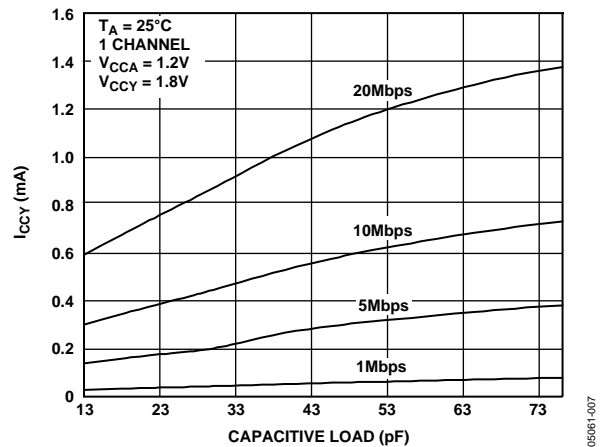

Figure 7.  $I_{CCY}$  vs. Capacitive Load at Pin Y for A Y (1.2 V 1.8 V) Level Translation

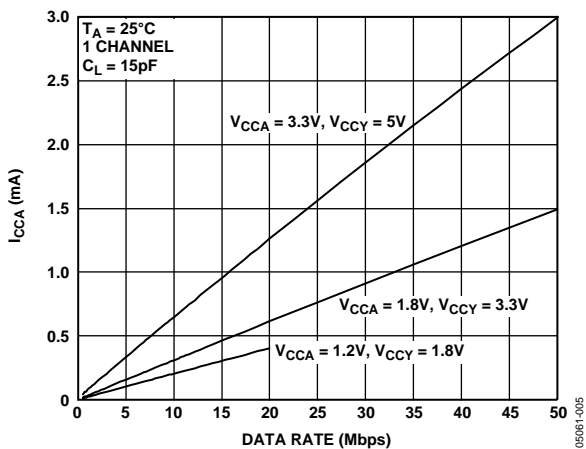

Figure 5.  $I_{CCA}$  vs. Data Rate (Y A Level Translation)

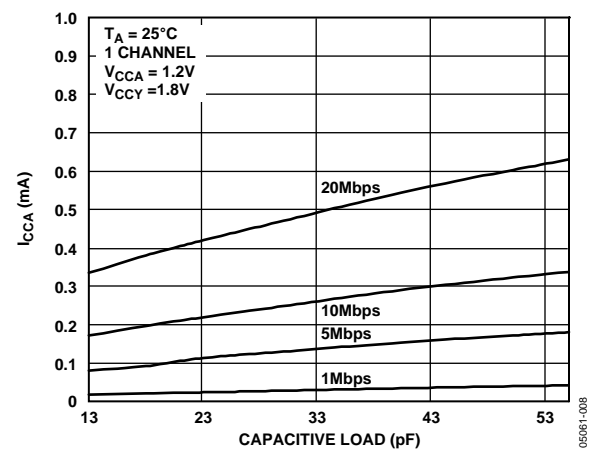

Figure 8.  $I_{CCA}$  vs. Capacitive Load at Pin A for Y A (1.8 V 1.2 V) Level Translation

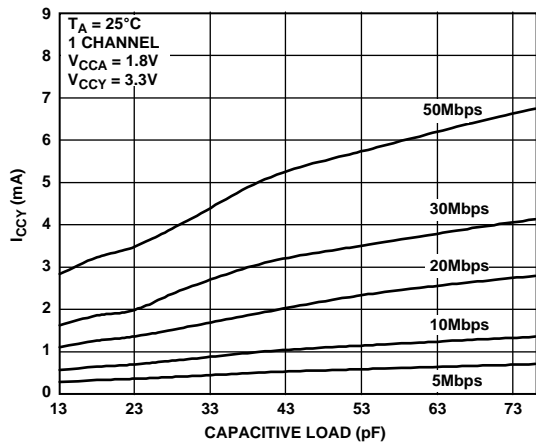

Figure 9.  $I_{CCY}$  vs. Capacitive Load at Pin Y for A Y (1.8 V 3.3 V) Level Translation

05061-009

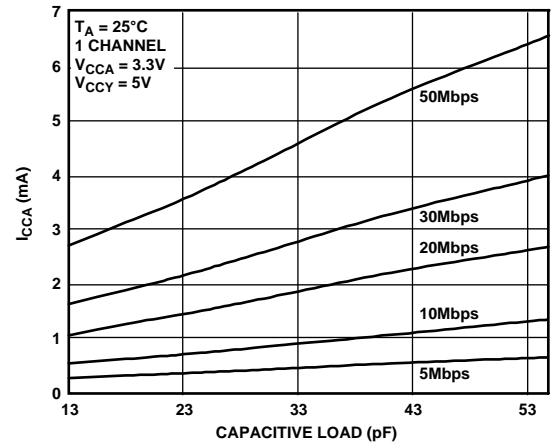

Figure 12.  $I_{CCA}$  vs. Capacitive Load at Pin A for Y A (5 V 3.3 V) Level Translation

05061-012

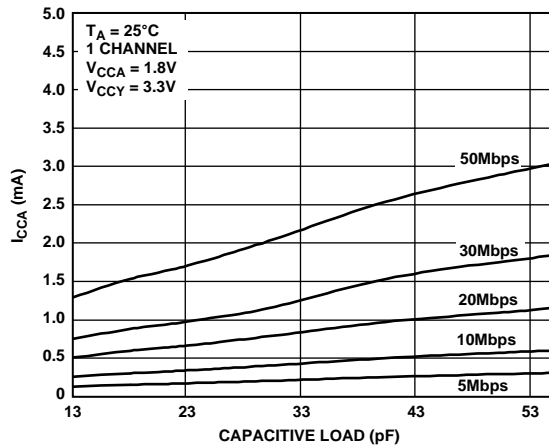

Figure 10.  $I_{CCA}$  vs. Capacitive Load at Pin A for Y A (3.3 V 1.8 V) Level Translation

05061-010

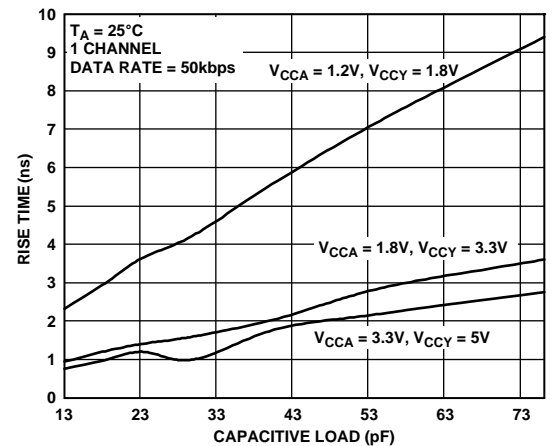

Figure 13. Rise Time vs. Capacitive Load at Pin Y (A Y Level Translation)

05061-013

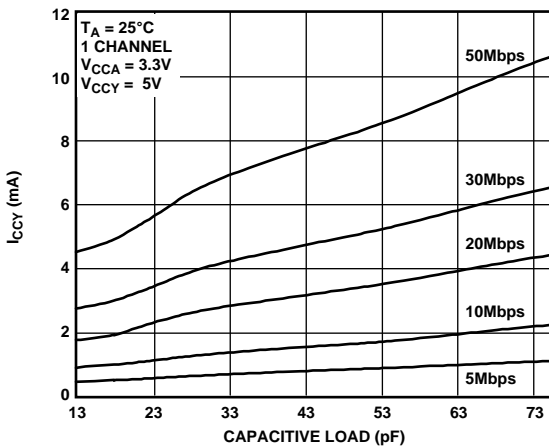

Figure 11.  $I_{CCY}$  vs. Capacitive Load at Pin Y for A Y (3.3 V 5 V) Level Translation

05061-011

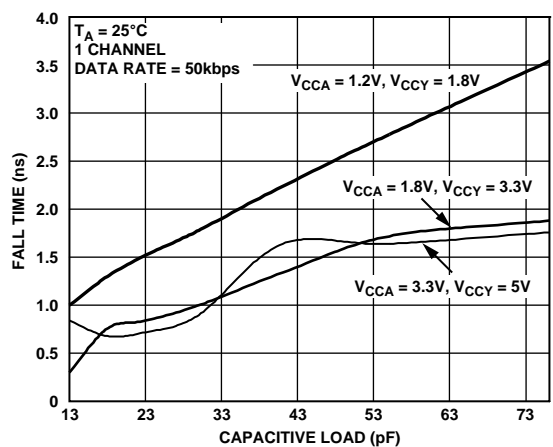

Figure 14. Fall Time vs. Capacitive Load at Pin Y (A Y Level Translation)

05061-014

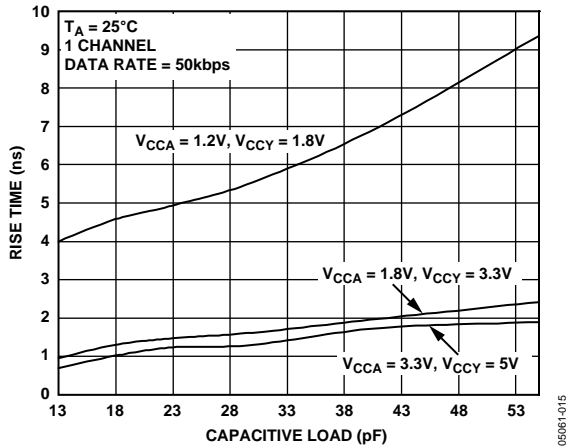

Figure 15. Rise Time vs. Capacitive Load at Pin A (Y A Level Translation)

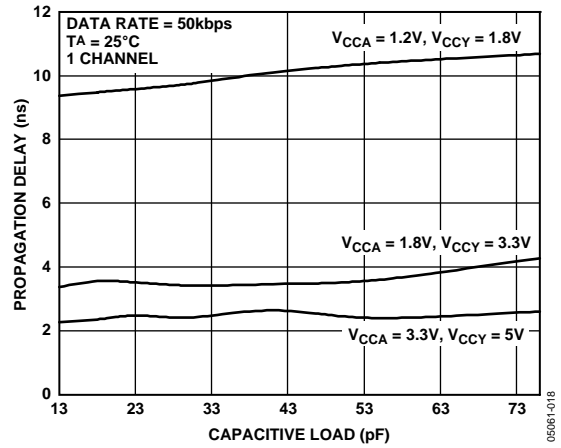

Figure 18. Propagation Delay ( $t_{PHL}$ ) vs. Capacitive Load at Pin Y (A Y Level Translation)

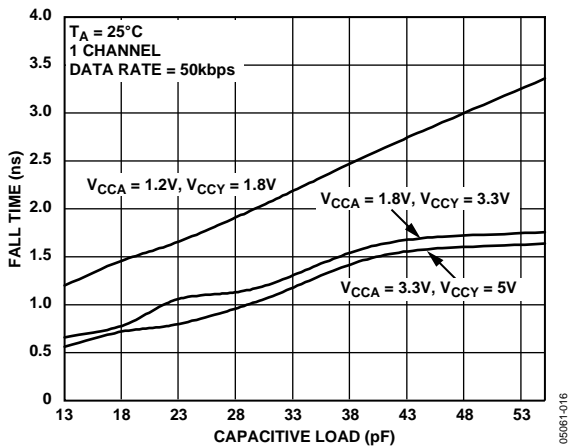

Figure 16. Fall Time vs. Capacitive Load at Pin A (Y A Level Translation)

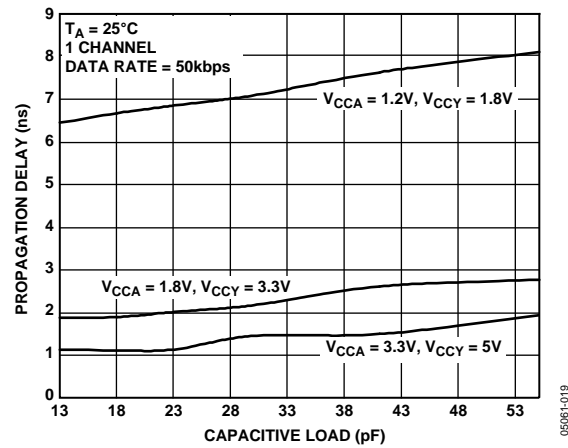

Figure 19. Propagation Delay ( $t_{PLH}$ ) vs. Capacitive Load at Pin A (Y A Level Translation)

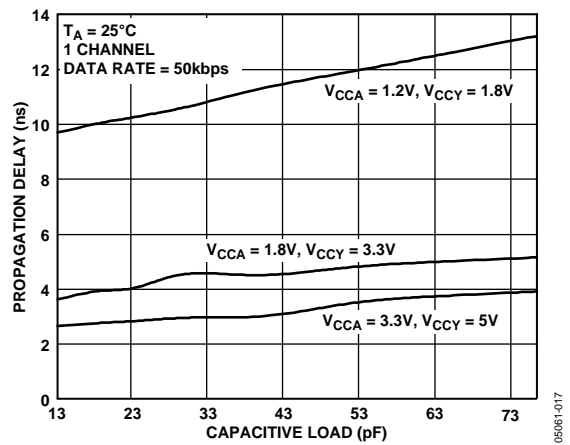

Figure 17. Propagation Delay ( $t_{PLH}$ ) vs. Capacitive Load at Pin Y (A Y Level Translation)

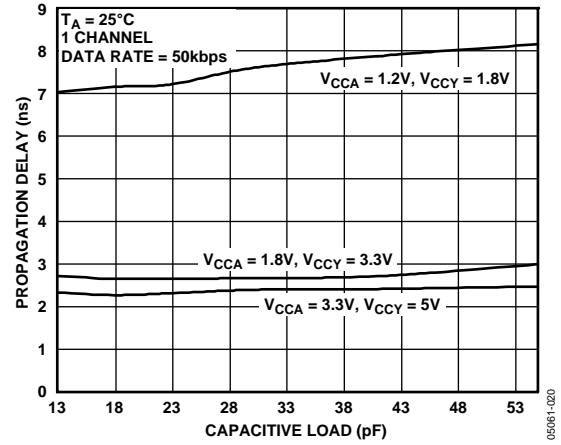

Figure 20. Propagation Delay ( $t_{PHL}$ ) vs. Capacitive Load at Pin A (Y A Level Translation)

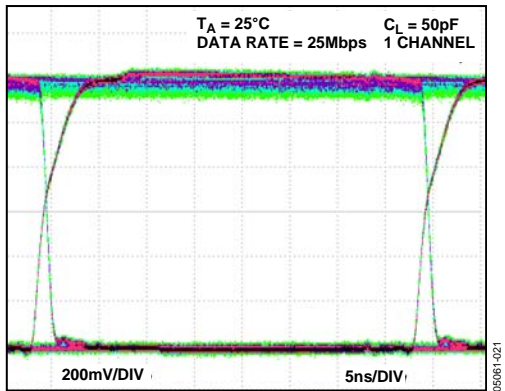

Figure 21. Eye Diagram at Y Output (1.2 V to 1.8 V Level Translation, 25 Mbps)

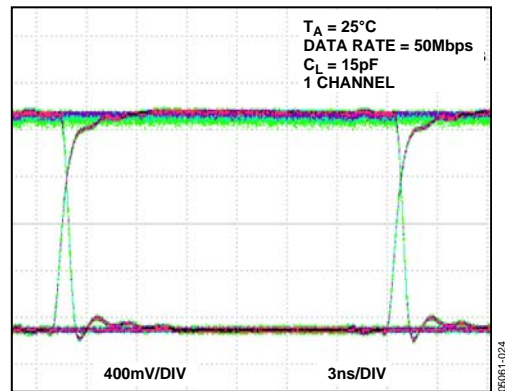

Figure 24. Eye Diagram at A Output (3.3 V to 1.8 V Level Translation, 50 Mbps)

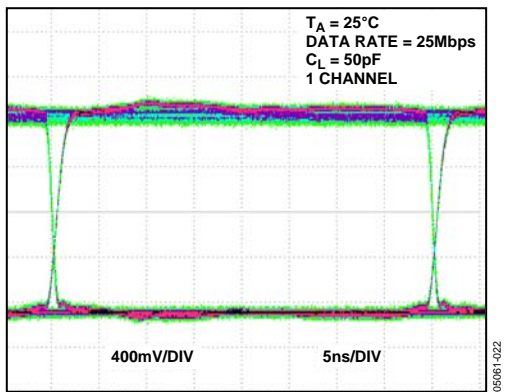

Figure 22. Eye Diagram at A Output (1.8 V to 1.2 V Level Translation, 25 Mbps)

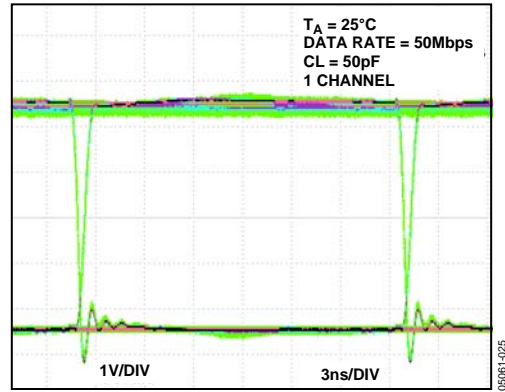

Figure 25. Eye Diagram at Y Output (3.3 V to 5 V Level Translation, 50 Mbps)

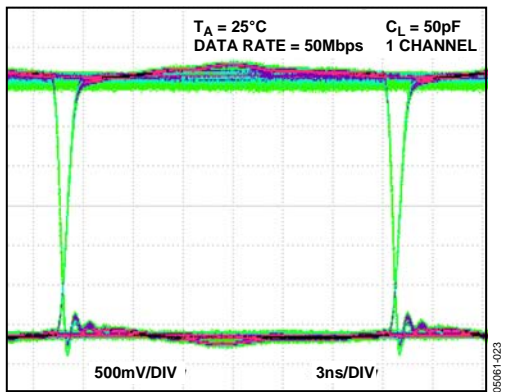

Figure 23. Eye Diagram at Y Output (1.8 V to 3.3 V Level Translation, 50 Mbps)

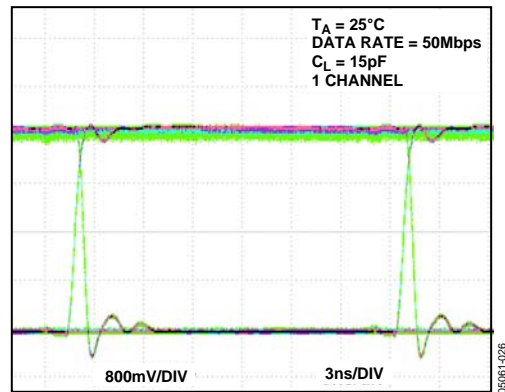

Figure 26. Eye Diagram at A Output (5 V to 3.3 V Level Translation, 50 Mbps)

# ADG3300

## TEST CIRCUITS

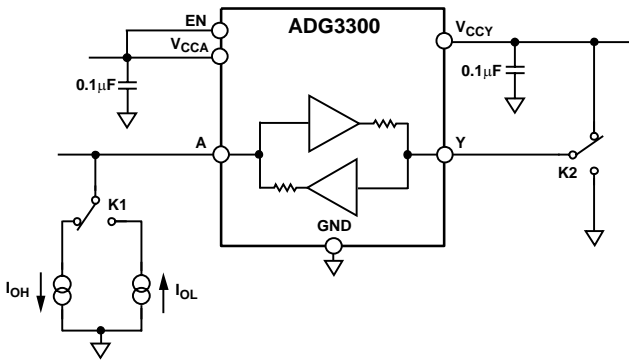

Figure 27.  $V_{OH}/V_{OL}$  Voltages at Pin A

05061-027

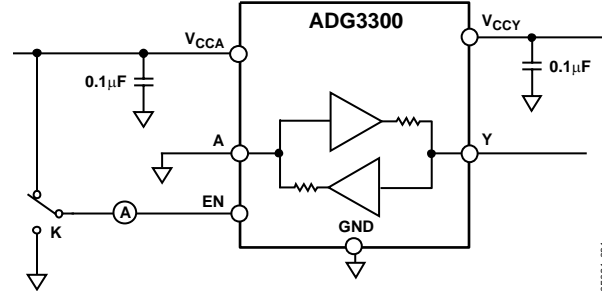

Figure 30. EN Pin Leakage Current

05061-031

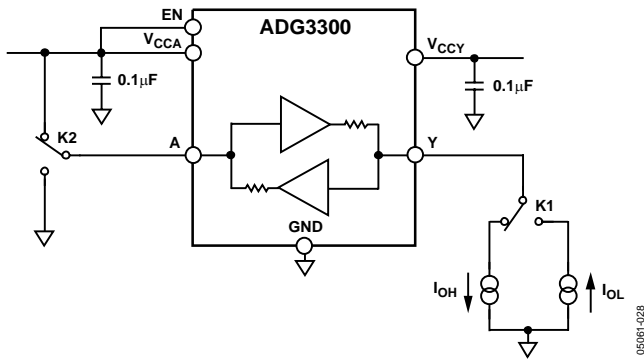

Figure 28.  $V_{OH}/V_{OL}$  Voltages at Pin Y

05061-028

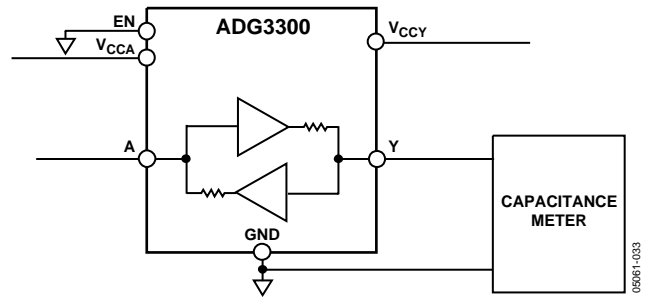

Figure 31. Capacitance at Pin Y

05061-033

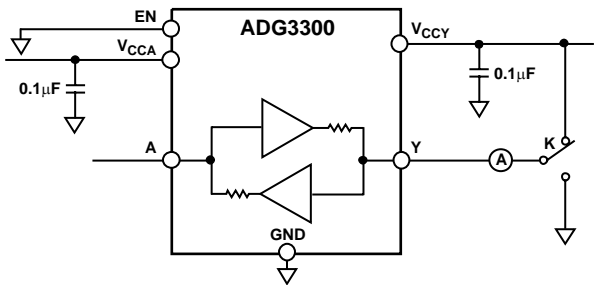
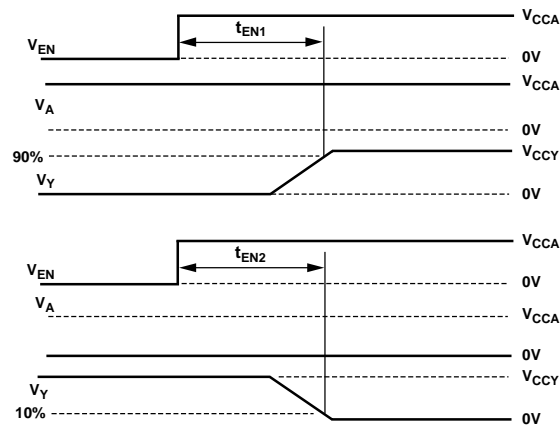
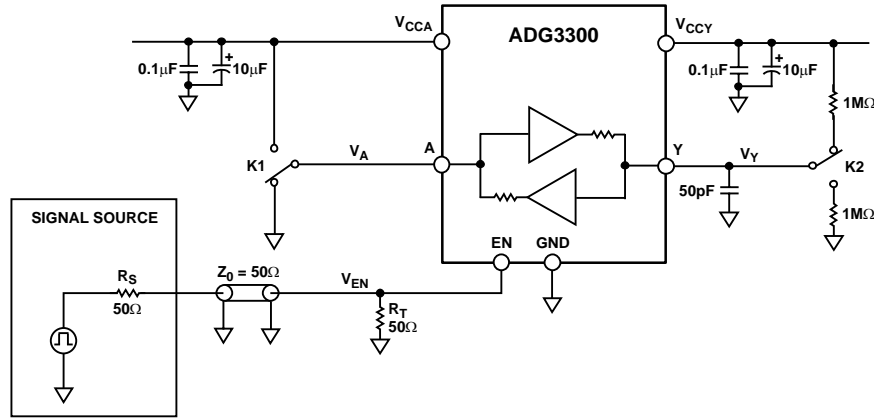

Figure 29. Three-State Leakage Current at Pin Y

05061-030



NOTES  
1. t<sub>EN</sub> IS WHICHEVER IS LARGER BETWEEN t<sub>EN1</sub> AND t<sub>EN2</sub>.

05061-034

Figure 32. Enable Time

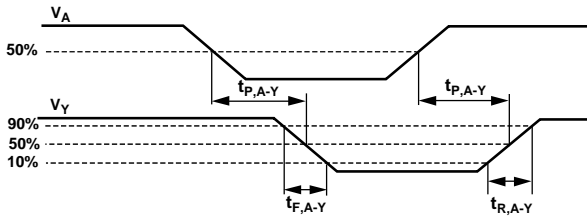
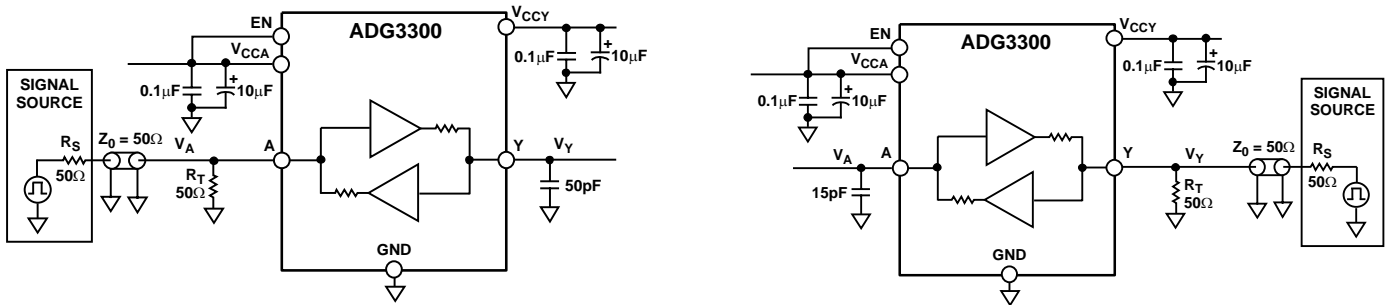

05061-035

Figure 33. Switching Characteristics (A Y Level Translation)

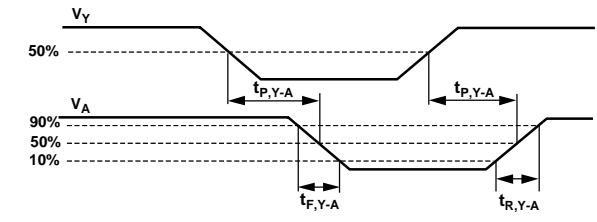

05061-036

Figure 34. Switching Characteristics (Y A Level Translation)

## TERMINOLOGY

Table 4.

Symbol	Description
$V_{IHA}$	Logic input high voltage at Pins A1 to A8.
$V_{ILA}$	Logic input low voltage at Pins A1 to A8.
$V_{OHA}$	Logic output high voltage at Pins A1 to A8.
$V_{OLA}$	Logic output low voltage at Pins A1 to A8.
$R_{A,HIZ}$	Pull-down resistance measured at Pins A1 to A8 when EN = 0.
$V_{IHY}$	Logic input high voltage at Pins Y1 to Y8.
$V_{ILY}$	Logic input low voltage at Pins Y1 to Y8.
$V_{OHY}$	Logic output high voltage at Pins Y1 to Y8.
$V_{OLY}$	Logic output low voltage at Pins Y1 to Y8.
$C_Y$	Capacitance measured at Pins Y1 to Y8 (EN = 0).
$I_{LY, HIZ}$	Leakage current at Pins Y1 to Y8 when EN = 0 (high impedance state at Pins Y1 to Y8).
$V_{IHEN}$	Logic input high voltage at the EN pin.
$V_{ILEN}$	Logic input low voltage at the EN pin.
$C_{EN}$	Capacitance measured at EN pin.
$I_{LEN}$	Enable (EN) pin leakage current.
$t_{EN}$	Three-state enable time for Pins Y1 to Y8.
$t_{P, A-Y}$	Propagation delay when translating logic levels in the A Y direction.
$t_{R, A-Y}$	Rise time when translating logic levels in the A Y direction.
$t_{F, A-Y}$	Fall time when translating logic levels in the A Y direction.
$D_{MAX, A-Y}$	Guaranteed data rate when translating logic levels in the A Y direction under the driving and loading conditions specified in Table 1.
$t_{SKEW, A-Y}$	Difference between propagation delays on any two channels when translating logic levels in the A Y direction.
$t_{PPSKEW, A-Y}$	Difference in propagation delay between any one channel and the same channel on a different part (under the same driving/loading conditions) when translating logic levels in the A Y direction.
$t_{P, Y-A}$	Propagation delay when translating logic levels in the Y A direction.
$t_{R, Y-A}$	Rise time when translating logic levels in the Y A direction.
$t_{F, Y-A}$	Fall time when translating logic levels in the Y A direction.
$D_{MAX, Y-A}$	Guaranteed data rate when translating logic levels in the Y A direction under the driving and loading conditions specified in Table 1.
$t_{SKEW, Y-A}$	Difference between propagation delays on any two channels when translating logic levels in the Y A direction.
$t_{PPSKEW, Y-A}$	Difference in propagation delay between any one channel and the same channel on a different part (under the same driving/loading conditions) when translating in the Y A direction.
$V_{CCA}$	$V_{CCA}$ supply voltage.
$V_{CCY}$	$V_{CCY}$ supply voltage.
$I_{CCA}$	$V_{CCA}$ supply current.
$I_{CCY}$	$V_{CCY}$ supply current.
$I_{HIZA}$	$V_{CCA}$ supply current during three-state mode (EN = 0).
$I_{HiZY}$	$V_{CCY}$ supply current during three-state mode (EN = 0).

## THEORY OF OPERATION

The ADG3300 level translator allows the level shifting necessary for data transfer in a system where multiple supply voltages are used. The device requires two supplies,  $V_{CCA}$  and  $V_{CCY}$  ( $V_{CCA} \leq V_{CCY}$ ). These supplies set the logic levels on each side of the device. When driving the A pins, the device translates the  $V_{CCA}$ -compatible logic levels to  $V_{CCY}$ -compatible logic levels available at the Y pins. Similarly, since the device is capable of bidirectional translation, when driving the Y pins, the  $V_{CCY}$ -compatible logic levels are translated to  $V_{CCA}$ -compatible logic levels available at the A pins. When  $EN = 0$ , the A1 to A8 are internally pulled down with  $6\text{ k}\Omega$  resistors while Y1 to Y8 pins are three-stated. When EN is driven high, the ADG3300 goes into normal operation mode and performs level translation.

### LEVEL TRANSLATOR ARCHITECTURE

The ADG3300 consists of eight bidirectional channels. Each channel can translate logic levels in either the A Y or the Y A direction. It uses a one-shot accelerator architecture, which ensures excellent switching characteristics. Figure 35 shows a simplified block diagram of a bidirectional channel.

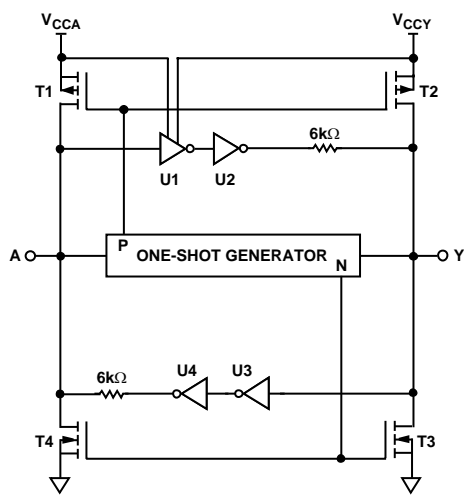

Figure 35. Simplified Block Diagram of an ADG3300 Channel

The logic level translation in the A Y direction is performed using a level translator (U1) and an inverter (U2), and the translation in the Y A direction is performed using the inverters U3 and U4. The one-shot generator detects a rising or falling edge present on either the A side or the Y side of the channel. It sends a short pulse that turns on the PMOS transistors (T1–T2) for a rising edge, or the NMOS transistors (T3–T4) for a falling edge. This charges/discharges the capacitive load faster, which results in fast rise and fall times.

The inputs of the unused channels (A or Y) should be tied to their corresponding  $V_{CC}$  rail ( $V_{CCA}$  or  $V_{CCY}$ ) or to GND.

### INPUT DRIVING REQUIREMENTS

To ensure correct operation of the ADG3300, the circuit that drives the input of an ADG3300 channels should have an output impedance of less than or equal to  $150\ \Omega$  and a minimum current driving capability of 36 mA.

### OUTPUT LOAD REQUIREMENTS

The ADG3300 level translator is designed to drive CMOS-compatible loads. If current driving capability is required, it is recommended to use buffers between the ADG3300 outputs and the load.

### ENABLE OPERATION

The ADG3300 provides three-state operation at the Y I/O pins by using the enable (EN) pin as shown in Table 5.

Table 5. Truth Table

EN	Y I/O Pins	A I/O Pins
0	Hi-Z <sup>1</sup>	$6\text{ k}\Omega$ pull-down to GND
1	Normal operation <sup>2</sup>	Normal operation <sup>2</sup>

<sup>1</sup> High impedance state.

<sup>2</sup> In normal operation, the ADG3300 performs level translation.

When  $EN = 0$ , the ADG3300 enters into three-state mode. In this mode the current consumption from both the  $V_{CCA}$  and  $V_{CCY}$  supplies is reduced, allowing the user to save power, which is critical, especially for battery-operated systems. The EN input pin can be driven with either  $V_{CCA}$ - or  $V_{CCY}$ -compatible logic levels.

### POWER SUPPLIES

For proper operation of the ADG3300, the voltage applied to the  $V_{CCA}$  must always be less than or equal to the voltage applied to  $V_{CCY}$ . To meet this condition, the recommended power-up sequence is  $V_{CCY}$  first and then  $V_{CCA}$ . The ADG3300 operates properly only after both supply voltages reach their nominal values. It is not recommended to use the part in a system where  $V_{CCA}$  might be greater than  $V_{CCY}$  during power-up due to a significant increase in the current taken from the  $V_{CCA}$  supply. For optimum performance, the  $V_{CCA}$  and  $V_{CCY}$  pins should be decoupled to GND as close as possible to the device.

# ADG3300

## DATA RATE

The maximum data rate at which the device is guaranteed to operate is a function of the  $V_{CCA}$  and  $V_{CCY}$  supply voltage combination and the load capacitance. It is given by the maximum frequency of a square wave that can be applied to the device, which meets the  $V_{OH}$  and  $V_{OL}$  levels at the output and does not exceed the maximum junction temperature (see Table 2). Table 6 shows the guaranteed data rates at which the ADG3300 can operate in both directions (A Y and Y A level translation) for various  $V_{CCA}$  and  $V_{CCY}$  supply combinations.

**Table 6. Guaranteed Data Rate (Mbps)<sup>1</sup>**

$V_{CCA}$	$V_{CCY}$			
	<b>1.8 V</b> <b>(1.65 V to 1.95 V)</b>	<b>2.5 V</b> <b>(2.3 V to 2.7 V)</b>	<b>3.3 V</b> <b>(3.0 V to 3.6 V)</b>	<b>5 V</b> <b>(4.5 V to 5.5 V)</b>
1.2 V (1.15 V to 1.3 V)	25	30	40	40
1.8 V (1.65 V to 1.95 V)	-	45	50	50
2.5 V (2.3 V to 2.7 V)	-	-	60	50
3.3 V (3.0 V to 3.6 V)	-	-	-	50
5 V (4.5 V to 5.5 V)	-	-	-	-

<sup>1</sup> The load capacitance used is 50 pF when translating in the A Y direction and 15 pF when translating in the Y A direction.

## APPLICATIONS

The ADG3300 is designed for digital circuits that operate at different supply voltages; therefore, logic level translation is required. The lower voltage logic signals are connected to the A pins, and the higher voltage logic signals are connected to the Y pins. The ADG3300 can provide level translation in both directions from A to Y and Y to A on all eight channels, eliminating the need for a level translator IC for each direction. The internal architecture allows the ADG3300 to perform bidirectional level translation without an additional signal to set the direction of the translation. It also allows simultaneous data flow in both directions on the same part, for example, four channels translate in the A to Y direction while the other four translate in the Y to A direction. This simplifies the design by eliminating the timing requirements for the direction signal and reduces the number of ICs used for level translation.

Figure 36 shows an application where a 1.8 V microprocessor can read or write data to or from a 3.3 V peripheral device using an 8-bit bus.

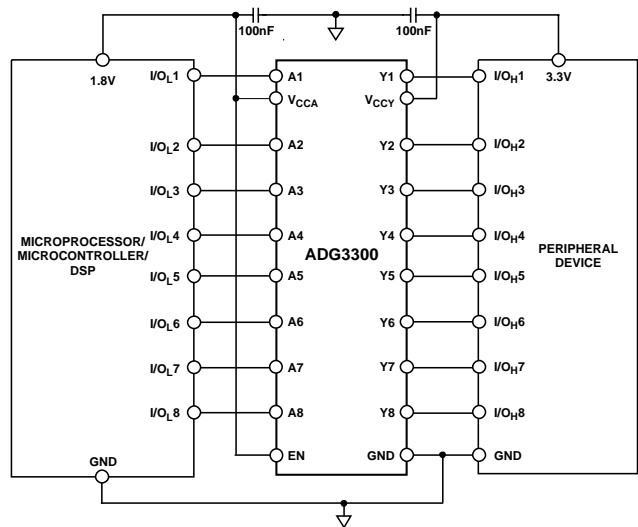

Figure 36. 1.8 V to 3.3 V 8-Bit Level Translation Circuit

When the application requires level translation between a microprocessor and multiple peripheral devices, the ADG3300 Y I/O pins (Y1 to Y8) can be three-stated by setting EN = 0. This feature allows the ADG3300 to share the data buses with

other devices without causing contention issues. Figure 37 shows an application where a 3.3 V microprocessor is connected to 1.8 V peripheral devices using the three-state feature.

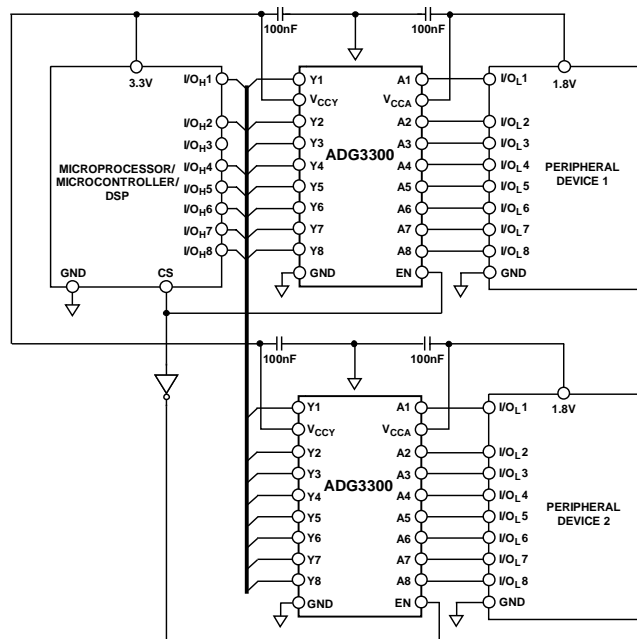

Figure 37. 1.8 V to 3.3 V Level Translation Circuit Using the Three-State Feature

## LAYOUT GUIDELINES

As with any high speed digital IC, the printed circuit board layout is important in the overall circuit performance. Care should be taken to ensure proper power supply bypass and return paths for the high speed signals. Each  $V_{CC}$  pin ( $V_{CCA}$  and  $V_{CCY}$ ) should be bypassed using low effective series resistance (ESR) and effective series inductance (ESI) capacitors placed as close as possible to the  $V_{CCA}$  and  $V_{CCY}$  pins. The parasitic inductance of the high speed signal track might cause significant overshoot. This effect can be reduced by keeping the length of the tracks as short as possible. A solid copper plane for the return path (GND) is also recommended.

## OUTLINE DIMENSIONS

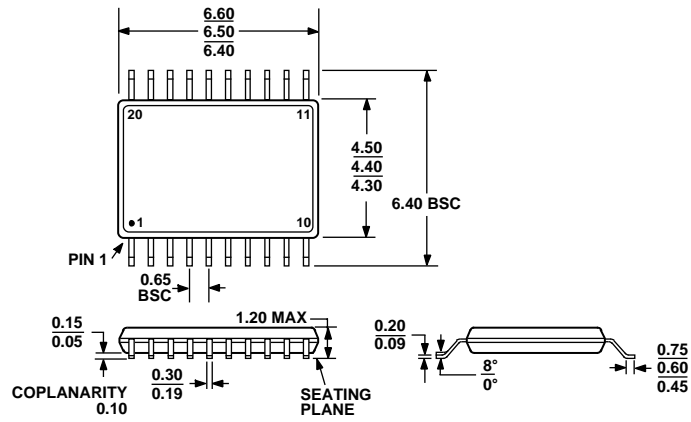

Figure 38. 20-Lead Thin Shrink Small Outline Package [TSSOP]  
(RU-20)  
Dimensions shown in millimeters

## ORDERING GUIDE

Model	Temperature Range	Package Description	Package Option
ADG3300BRUZ <sup>1</sup>	-40°C to +85°C	TSSOP	RU-20
ADG3300BRUZ-REEL <sup>1</sup>	-40°C to +85°C	TSSOP	RU-20
ADG3300BRUZ-REEL7 <sup>1</sup>	-40°C to +85°C	TSSOP	RU-20

<sup>1</sup> Z = Pb-free part.

**NOTES**

**ADG3300**

**NOTES**

## Looking for pricing, stock, or lifecycle information?

Click below to explore more details on WIN SOURCE:

 [View ADG3300BRUZ on WIN SOURCE](#)

 [Analog Devices Inc. Information](#)

## Optimize Your Supply Chain with WIN SOURCE Solutions

-  Global Sourcing Solution
-  Obsolete Management
-  Cost Control Management
-  Shortage Management
-  Alternative Solution
-  Excess Inventory Management