



**THE DATASHEET OF
ADG1636BRUZ**



FEATURES

- 1 Ω typical on resistance
- 0.2 Ω on resistance flatness
- ± 3.3 V to ± 8 V dual supply operation
- 3.3 V to 16 V single supply operation
- No V_L supply required
- 3 V logic-compatible inputs
- Rail-to-rail operation
- Continuous current per channel
 - LFCSP: 385 mA
 - TSSOP: 238 mA
- 16-lead TSSOP and 16-lead, 4 mm \times 4 mm LFCSP

APPLICATIONS

- Communication systems
- Medical systems
- Audio signal routing
- Video signal routing
- Automatic test equipment
- Data acquisition systems
- Battery-powered systems
- Sample-and-hold systems
- Relay replacements

GENERAL DESCRIPTION

The **ADG1636** is a monolithic CMOS device containing two independently selectable single-pole/double-throw (SPDT) switches. An EN input is used to enable or disable the device. When disabled, all channels are switched off. Each switch conducts equally well in both directions when on and has an input signal range that extends to the supplies. In the off condition, signal levels up to the supplies are blocked. Both switches exhibit break-before-make switching action for use in multiplexer applications.

The ultralow on resistance of these switches make them ideal solutions for data acquisition and gain switching applications where low on resistance and distortion is critical. The on resistance profile is very flat over the full analog input range, ensuring excellent linearity and low distortion when switching audio signals.

FUNCTIONAL BLOCK DIAGRAMS

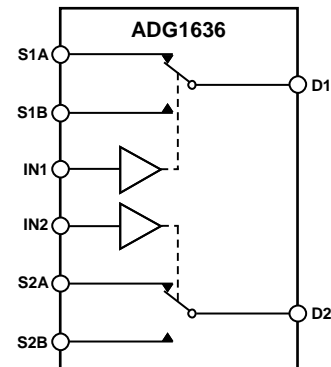

- NOTES
1. SWITCHES SHOWN FOR A LOGIC 1 INPUT.

Figure 1. 16-Lead TSSOP

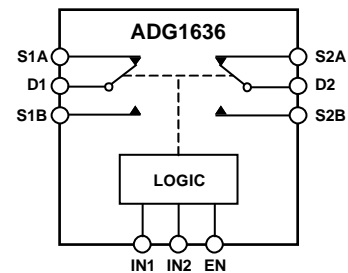

- NOTES
1. SWITCHES SHOWN FOR A 1 INPUT LOGIC.

Figure 2. 16-Lead LFCSP

The CMOS construction ensures ultralow power dissipation, making the devices ideally suited for portable and battery-powered instruments.

PRODUCT HIGHLIGHTS

1. 1.6 Ω maximum on resistance over temperature.
2. Minimum distortion: THD + N = 0.007%.
3. 3 V logic-compatible digital inputs: $V_{INH} = 2.0$ V, $V_{INL} = 0.8$ V.
4. No V_L logic power supply required.
5. Ultralow power dissipation: <16 nW.
6. 16-lead TSSOP and 16-lead 4 mm \times 4 mm LFCSP.

Rev. B

[Document Feedback](#)

Information furnished by Analog Devices is believed to be accurate and reliable. However, no responsibility is assumed by Analog Devices for its use, nor for any infringements of patents or other rights of third parties that may result from its use. Specifications subject to change without notice. No license is granted by implication or otherwise under any patent or patent rights of Analog Devices. Trademarks and registered trademarks are the property of their respective owners.

TABLE OF CONTENTS

Features	1	3.3 V Single Supply.....	6
Applications.....	1	Continuous Current per Channel, S or D.....	7
General Description	1	Absolute Maximum Ratings	8
Functional Block Diagrams.....	1	ESD Caution.....	8
Product Highlights	1	Pin Configurations and Function Descriptions	9
Revision History	2	Typical Performance Characteristics	10
Specifications.....	3	Test Circuits.....	13
±5 V Dual Supply	3	Terminology	15
12 V Single Supply.....	4	Outline Dimensions	16
5 V Single Supply.....	5	Ordering Guide	16

REVISION HISTORY

3/16—Rev. A to Rev. B

Changed CP-16-13 to CP-16-26	Throughout
Changes to Figure 3, Figure 4, and Table 7	9
Updated Outline Dimensions	16
Changes to Ordering Guide	16

9/09—Rev. 0 to Rev. A

Changes to Table 4.....	6
-------------------------	---

1/09—Revision 0: Initial Version

SPECIFICATIONS

±5 V DUAL SUPPLY

$V_{DD} = +5\text{ V} \pm 10\%$, $V_{SS} = -5\text{ V} \pm 10\%$, GND = 0 V, unless otherwise noted.

Table 1.

Parameter	25°C	-40°C to +85°C	-40°C to +125°C	Unit	Test Conditions/Comments
ANALOG SWITCH					
Analog Signal Range			V_{DD} to V_{SS}	V	
On Resistance (R_{ON})	1			Ω typ	$V_S = \pm 4.5\text{ V}$, $I_S = -10\text{ mA}$; see Figure 23
	1.2	1.4	1.6	Ω max	$V_{DD} = \pm 4.5\text{ V}$, $V_{SS} = \pm 4.5\text{ V}$
On Resistance Match Between Channels (ΔR_{ON})	0.04			Ω typ	$V_S = \pm 4.5\text{ V}$, $I_S = -10\text{ mA}$
	0.08	0.09	0.1	Ω max	
On Resistance Flatness ($R_{FLAT(ON)}$)	0.2			Ω typ	$V_S = \pm 4.5\text{ V}$, $I_S = -10\text{ mA}$
	0.25	0.29	0.34	Ω max	
LEAKAGE CURRENTS					
Source Off Leakage, I_S (Off)	± 0.1			nA typ	$V_{DD} = +5.5\text{ V}$, $V_{SS} = -5.5\text{ V}$
	± 0.25	± 1	± 4	nA max	$V_S = \pm 4.5\text{ V}$, $V_D = \mp 4.5\text{ V}$; see Figure 24
Drain Off Leakage, I_D (Off)	± 0.1			nA typ	$V_S = \pm 4.5\text{ V}$, $V_D = \mp 4.5\text{ V}$; see Figure 24
	± 0.25	± 2	± 10	nA max	
Channel On Leakage, I_D , I_S (On)	± 0.3			nA typ	$V_S = V_D = \pm 4.5\text{ V}$; see Figure 25
	± 0.6	± 2	± 12	nA max	
DIGITAL INPUTS					
Input High Voltage, V_{INH}			2.0	V min	
Input Low Voltage, V_{INL}			0.8	V max	
Input Current, I_{INL} or I_{INH}	0.005			μA typ	$V_{IN} = V_{GND}$ or V_{DD}
			± 0.1	μA max	
Digital Input Capacitance, C_{IN}	5			pF typ	
DYNAMIC CHARACTERISTICS¹					
Transition Time, $t_{TRANSITION}$	130			ns typ	$R_L = 300\ \Omega$, $C_L = 35\text{ pF}$
	209	245	273	ns max	$V_S = 2.5\text{ V}$; see Figure 30
t_{ON} (EN)	119			ns typ	$R_L = 300\ \Omega$, $C_L = 35\text{ pF}$
	148	166	176	ns max	$V_S = 2.5\text{ V}$; see Figure 30
t_{OFF} (EN)	182			ns typ	$R_L = 300\ \Omega$, $C_L = 35\text{ pF}$
	228	259	281	ns max	$V_S = 2.5\text{ V}$; see Figure 30
Break-Before-Make Time Delay, t_D	30			ns typ	$R_L = 300\ \Omega$, $C_L = 35\text{ pF}$
			17	ns min	$V_{S1} = V_{S2} = 2.5\text{ V}$; see Figure 31
Charge Injection	130			pC typ	$V_S = 0\text{ V}$, $R_S = 0\ \Omega$, $C_L = 1\text{ nF}$; see Figure 32
Off Isolation	70			dB typ	$R_L = 50\ \Omega$, $C_L = 5\text{ pF}$, $f = 1\text{ MHz}$; see Figure 26
Channel-to-Channel Crosstalk	90			dB typ	$R_L = 50\ \Omega$, $C_L = 5\text{ pF}$, $f = 1\text{ MHz}$; see Figure 28
Total Harmonic Distortion + Noise (THD + N)	0.007			% typ	$R_L = 110\ \Omega$, 5 V p-p , $f = 20\text{ Hz to } 20\text{ kHz}$; see Figure 29
-3 dB Bandwidth	25			MHz typ	$R_L = 50\ \Omega$, $C_L = 5\text{ pF}$; see Figure 27
C_S (Off)	68			pF typ	$V_S = 0\text{ V}$, $f = 1\text{ MHz}$
C_D (Off)	127			pF typ	$V_S = 0\text{ V}$, $f = 1\text{ MHz}$
C_D , C_S (On)	220			pF typ	$V_S = 0\text{ V}$, $f = 1\text{ MHz}$
POWER REQUIREMENTS					
I_{DD}	0.001			μA typ	$V_{DD} = +5.5\text{ V}$, $V_{SS} = -5.5\text{ V}$
			1.0	μA max	Digital inputs = 0 V or V_{DD}
V_{DD}/V_{SS}			$\pm 3.3/\pm 8$	V min/max	

¹ Guaranteed by design, not subject to production test.

12 V SINGLE SUPPLY

$V_{DD} = 12\text{ V} \pm 10\%$, $V_{SS} = 0\text{ V}$, $GND = 0\text{ V}$, unless otherwise noted.

Table 2.

Parameter	25°C	-40°C to +85°C	-40°C to +125°C	Unit	Test Conditions/Comments
ANALOG SWITCH					
Analog Signal Range			0 V to V_{DD}	V	
On Resistance (R_{ON})	0.95			Ω typ	$V_S = 0\text{ V to }10\text{ V}$, $I_S = -10\text{ mA}$; see Figure 23
	1.1	1.25	1.45	Ω max	$V_{DD} = 10.8\text{ V}$, $V_{SS} = 0\text{ V}$
On Resistance Match Between Channels (ΔR_{ON})	0.03			Ω typ	$V_S = 10\text{ V}$, $I_S = -10\text{ mA}$
	0.06	0.07	0.08	Ω max	
On Resistance Flatness ($R_{FLAT(ON)}$)	0.2			Ω typ	$V_S = 0\text{ V to }10\text{ V}$, $I_S = -10\text{ mA}$
	0.23	0.27	0.32	Ω max	
LEAKAGE CURRENTS					
Source Off Leakage, I_S (Off)	± 0.1			nA typ	$V_{DD} = 13.2\text{ V}$, $V_{SS} = 0\text{ V}$ $V_S = 1\text{ V}/10\text{ V}$, $V_S = 10\text{ V}/1\text{ V}$; see Figure 24
	± 0.25	± 1	± 4	nA max	
Drain Off Leakage, I_D (Off)	± 0.1			nA typ	$V_S = 1\text{ V}/10\text{ V}$, $V_S = 10\text{ V}/1\text{ V}$; see Figure 24
	± 0.25	± 2	± 10	nA max	
Channel On Leakage, I_D , I_S (On)	± 0.3			nA typ	$V_S = V_D = 1\text{ V or }10\text{ V}$; see Figure 25
	± 0.6	± 2	± 12	nA max	
DIGITAL INPUTS					
Input High Voltage, V_{INH}			2.0	V min	
Input Low Voltage, V_{INL}			0.8	V max	
Input Current, I_{INL} or I_{INH}	0.001			μA typ	$V_{IN} = V_{GND}$ or V_{DD}
			± 0.1	μA max	
Digital Input Capacitance, C_{IN}	5			pF typ	
DYNAMIC CHARACTERISTICS¹					
Transition Time, $t_{TRANSITION}$	100			ns typ	$R_L = 300\ \Omega$, $C_L = 35\text{ pF}$
	153	183	206	ns max	$V_S = 8\text{ V}$; see Figure 30
t_{ON} (EN)	80			ns typ	$R_L = 300\ \Omega$, $C_L = 35\text{ pF}$
	95	103	110	ns max	$V_S = 8\text{ V}$; see Figure 30
t_{OFF} (EN)	133			ns typ	$R_L = 300\ \Omega$, $C_L = 35\text{ pF}$
	161	187	210	ns max	$V_S = 8\text{ V}$; see Figure 30
Break-Before-Make Time Delay, t_D	25			ns typ	$R_L = 300\ \Omega$, $C_L = 35\text{ pF}$
			17	ns min	$V_{S1} = V_{S2} = 8\text{ V}$; see Figure 31
Charge Injection	150			pC typ	$V_S = 6\text{ V}$, $R_S = 0\ \Omega$, $C_L = 1\text{ nF}$; see Figure 32
Off Isolation	70			dB typ	$R_L = 50\ \Omega$, $C_L = 5\text{ pF}$, $f = 1\text{ MHz}$; see Figure 26
Channel-to-Channel Crosstalk	90			dB typ	$R_L = 50\ \Omega$, $C_L = 5\text{ pF}$, $f = 1\text{ MHz}$; see Figure 28
Total Harmonic Distortion + Noise (THD + N)	0.013			% typ	$R_L = 110\ \Omega$, 5 V p-p , $f = 20\text{ Hz to }20\text{ kHz}$; see Figure 29
-3 dB Bandwidth	27			MHz typ	$R_L = 50\ \Omega$, $C_L = 5\text{ pF}$; see Figure 27
C_S (Off)	65			pF typ	$V_S = 6\text{ V}$, $f = 1\text{ MHz}$
C_D (Off)	120			pF typ	$V_S = 6\text{ V}$, $f = 1\text{ MHz}$
C_D , C_S (On)	216			pF typ	$V_S = 6\text{ V}$, $f = 1\text{ MHz}$
POWER REQUIREMENTS					
I_{DD}	0.001			μA typ	$V_{DD} = 12\text{ V}$ Digital inputs = 0 V or V_{DD}
			1	μA max	
I_{DD}	230			μA typ	Digital inputs = 5 V
			360	μA max	
V_{DD}			3.3/16	V min/max	

¹ Guaranteed by design, not subject to production test.

5 V SINGLE SUPPLY

$V_{DD} = 5\text{ V} \pm 10\%$, $V_{SS} = 0\text{ V}$, $GND = 0\text{ V}$, unless otherwise noted.

Table 3.

Parameter	25°C	-40°C to +85°C	-40°C to 125°C	Unit	Test Conditions/Comments
ANALOG SWITCH					
Analog Signal Range			0 V to V_{DD}	V	
On Resistance (R_{ON})	1.7			Ω typ	$V_S = 0\text{ V to }4.5\text{ V}$, $I_S = -10\text{ mA}$; see Figure 23
	2.15	2.4	2.7	Ω max	$V_{DD} = 4.5\text{ V}$, $V_{SS} = 0\text{ V}$
On Resistance Match Between Channels (ΔR_{ON})	0.05			Ω typ	$V_S = 0\text{ V to }4.5\text{ V}$, $I_S = -10\text{ mA}$
	0.09	0.12	0.15	Ω max	
On Resistance Flatness ($R_{FLAT(ON)}$)	0.4			Ω typ	$V_S = 0\text{ V to }4.5\text{ V}$, $I_S = -10\text{ mA}$
	0.53	0.55	0.6	Ω max	
LEAKAGE CURRENTS					
Source Off Leakage, I_S (Off)	± 0.05			nA typ	$V_{DD} = 5.5\text{ V}$, $V_{SS} = 0\text{ V}$
	± 0.25	± 1	± 4	nA max	$V_S = 1\text{ V}/4.5\text{ V}$, $V_D = 4.5\text{ V}/1\text{ V}$; see Figure 24
Drain Off Leakage, I_D (Off)	± 0.05			nA typ	$V_S = 1\text{ V}/4.5\text{ V}$, $V_D = 4.5\text{ V}/1\text{ V}$; see Figure 24
	± 0.25	± 2	± 10	nA max	
Channel On Leakage, I_D , I_S (On)	± 0.1			nA typ	$V_S = V_D = 1\text{ V or }4.5\text{ V}$; see Figure 25
	± 0.6	± 2	± 12	nA max	
DIGITAL INPUTS					
Input High Voltage, V_{INH}			2.0	V min	
Input Low Voltage, V_{INL}			0.8	V max	
Input Current, I_{INL} or I_{INH}	0.001			μA typ	$V_{IN} = V_{GND}$ or V_{DD}
			± 0.1	μA max	
Digital Input Capacitance, C_{IN}	5			pF typ	
DYNAMIC CHARACTERISTICS¹					
Transition Time, $t_{TRANSITION}$	160			ns typ	$R_L = 300\ \Omega$, $C_L = 35\text{ pF}$
	271	319	355	ns max	$V_S = 2.5\text{ V}$; see Figure 30
t_{ON} (EN)	132			ns typ	$R_L = 300\ \Omega$, $C_L = 35\text{ pF}$
	172	185	201	ns max	$V_S = 2.5\text{ V}$; see Figure 30
t_{OFF} (EN)	210			ns typ	$R_L = 300\ \Omega$, $C_L = 35\text{ pF}$
	268	313	345	ns max	$V_S = 2.5\text{ V}$; see Figure 30
Break-Before-Make Time Delay, t_D	30			ns typ	$R_L = 300\ \Omega$, $C_L = 35\text{ pF}$
			17	ns min	$V_{S1} = V_{S2} = 2.5\text{ V}$; see Figure 31
Charge Injection	70			pC typ	$V_S = 2.5\text{ V}$, $R_S = 0\ \Omega$, $C_L = 1\text{ nF}$; see Figure 32
Off Isolation	70			dB typ	$R_L = 50\ \Omega$, $C_L = 5\text{ pF}$, $f = 100\text{ kHz}$; see Figure 26
Channel-to-Channel Crosstalk	90			dB typ	$R_L = 50\ \Omega$, $C_L = 5\text{ pF}$, $f = 100\text{ kHz}$; see Figure 28
Total Harmonic Distortion + Noise (THD + N)	0.09			% typ	$R_L = 110\ \Omega$, $f = 20\text{ Hz to }20\text{ kHz}$, $V_S = 3.5\text{ V p-p}$; see Figure 29
-3 dB Bandwidth	26			MHz typ	$R_L = 50\ \Omega$, $C_L = 5\text{ pF}$; see Figure 27
C_S (Off)	76			pF typ	$V_S = 2.5\text{ V}$, $f = 1\text{ MHz}$
C_D (Off)	145			pF typ	$V_S = 2.5\text{ V}$, $f = 1\text{ MHz}$
C_D , C_S (On)	237			pF typ	$V_S = 2.5\text{ V}$, $f = 1\text{ MHz}$
POWER REQUIREMENTS					
I_{DD}	0.001			μA typ	$V_{DD} = 5.5\text{ V}$
		1.0	1.0	μA max	Digital inputs = 0 V or V_{DD}
V_{DD}			3.3/16	V min/max	

¹ Guaranteed by design, not subject to production test.

3.3 V SINGLE SUPPLY

$V_{DD} = 3.3\text{ V}$, $V_{SS} = 0\text{ V}$, $GND = 0\text{ V}$, unless otherwise noted.

Table 4.

Parameter	25°C	-40°C to +85°C	-40°C to +125°C	Unit	Test Conditions/Comments
ANALOG SWITCH					
Analog Signal Range			0 V to V_{DD}	V	
On Resistance (R_{ON})	3.2	3.4	3.6	Ω typ	$V_S = 0\text{ V to }V_{DD}$, $I_S = -10\text{ mA}$; see Figure 23 $V_{DD} = 3.3\text{ V}$, $V_{SS} = 0\text{ V}$
On Resistance Match Between Channels (ΔR_{ON})	0.06	0.07	0.08	Ω typ	$V_S = 0\text{ V to }V_{DD}$, $I_S = -10\text{ mA}$
On Resistance Flatness ($R_{FLAT(ON)}$)	1.2	1.3	1.4	Ω typ	$V_S = 0\text{ V to }V_{DD}$, $I_S = -10\text{ mA}$
LEAKAGE CURRENTS					
Source Off Leakage, I_S (Off)	± 0.02			nA typ	$V_{DD} = 3.6\text{ V}$, $V_{SS} = 0\text{ V}$ $V_S = 0.6\text{ V}/3\text{ V}$, $V_D = 3\text{ V}/0.6\text{ V}$; see Figure 24
	± 0.25	± 1	± 4	nA max	
Drain Off Leakage, I_D (Off)	± 0.02			nA typ	$V_S = 0.6\text{ V}/3\text{ V}$, $V_D = 3\text{ V}/0.6\text{ V}$; see Figure 24
	± 0.25	± 2	± 10	nA max	
Channel On Leakage, I_D , I_S (On)	± 0.05			nA typ	$V_S = V_D = 0.6\text{ V or }3\text{ V}$; see Figure 25
	± 0.6	± 2	± 12	nA max	
DIGITAL INPUTS					
Input High Voltage, V_{INH}			2.0	V min	
Input Low Voltage, V_{INL}			0.8	V max	
Input Current, I_{INL} or I_{INH}	0.001			μA typ	$V_{IN} = V_{GND}$ or V_{DD}
			± 0.1	μA max	
Digital Input Capacitance, C_{IN}	5			pF typ	
DYNAMIC CHARACTERISTICS¹					
Transition Time, $t_{TRANSITION}$	275			ns typ	$R_L = 300\ \Omega$, $C_L = 35\text{ pF}$
	449	506	550	ns max	$V_S = 1.5\text{ V}$; see Figure 30
t_{ON} (EN)	225			ns typ	$R_L = 300\ \Omega$, $C_L = 35\text{ pF}$
	306	327	338	ns max	$V_S = 1.5\text{ V}$; see Figure 30
t_{OFF} (EN)	340			ns typ	$R_L = 300\ \Omega$, $C_L = 35\text{ pF}$
	454	512	553	ns max	$V_S = 1.5\text{ V}$; see Figure 30
Break-Before-Make Time Delay, t_D	50			ns typ	$R_L = 300\ \Omega$, $C_L = 35\text{ pF}$
			28	ns min	$V_{S1} = V_{S2} = 1.5\text{ V}$; see Figure 31
Charge Injection	50			pC typ	$V_S = 1.5\text{ V}$, $R_S = 0\ \Omega$, $C_L = 1\text{ nF}$; see Figure 32
Off Isolation	70			dB typ	$R_L = 50\ \Omega$, $C_L = 5\text{ pF}$, $f = 100\text{ kHz}$; see Figure 26
Channel-to-Channel Crosstalk	90			dB typ	$R_L = 50\ \Omega$, $C_L = 5\text{ pF}$, $f = 100\text{ kHz}$; see Figure 28
Total Harmonic Distortion + Noise (THD + N)	0.19			% typ	$R_L = 33\ \Omega$, $f = 20\text{ Hz to }20\text{ kHz}$, $V_S = 2\text{ V p-p}$; see Figure 29
-3 dB Bandwidth	26			MHz typ	$R_L = 50\ \Omega$, $C_L = 5\text{ pF}$; see Figure 27
C_S (Off)	80			pF typ	$V_S = 1.5\text{ V}$, $f = 1\text{ MHz}$
C_D (Off)	153			pF typ	$V_S = 1.5\text{ V}$, $f = 1\text{ MHz}$
C_D , C_S (On)	243			pF typ	$V_S = 1.5\text{ V}$, $f = 1\text{ MHz}$
POWER REQUIREMENTS					
I_{DD}	0.001			μA typ	$V_{DD} = 3.6\text{ V}$ Digital inputs = 0 V or V_{DD}
		1.0	1.0	μA max	
V_{DD}			3.3/16	V min/max	

¹ Guaranteed by design, not subject to production test.

CONTINUOUS CURRENT PER CHANNEL, S OR D

Table 5.

Parameter	25°C	85°C	125°C	Unit
CONTINUOUS CURRENT, S OR D				
$V_{DD} = +5\text{ V}, V_{SS} = -5\text{ V}$				
TSSOP ($\theta_{JA} = 150.4^\circ\text{C/W}$)	238	151	88	mA maximum
LFCSP ($\theta_{JA} = 48.7^\circ\text{C/W}$)	385	220	105	mA maximum
$V_{DD} = 12\text{ V}, V_{SS} = 0\text{ V}$				
TSSOP ($\theta_{JA} = 150.4^\circ\text{C/W}$)	280	175	98	mA maximum
LFCSP ($\theta_{JA} = 48.7^\circ\text{C/W}$)	469	259	119	mA maximum
$V_{DD} = 5\text{ V}, V_{SS} = 0\text{ V}$				
TSSOP ($\theta_{JA} = 150.4^\circ\text{C/W}$)	189	126	77	mA maximum
LFCSP ($\theta_{JA} = 48.7^\circ\text{C/W}$)	301	182	98	mA maximum
$V_{DD} = 3.3\text{ V}, V_{SS} = 0\text{ V}$				
TSSOP ($\theta_{JA} = 150.4^\circ\text{C/W}$)	189	130	84	mA maximum
LFCSP ($\theta_{JA} = 48.7^\circ\text{C/W}$)	305	189	105	mA maximum

ABSOLUTE MAXIMUM RATINGS

$T_A = 25^\circ\text{C}$, unless otherwise noted.

Table 6.

Parameter	Rating
V_{DD} to V_{SS}	18 V
V_{DD} to GND	-0.3 V to +18 V
V_{SS} to GND	+0.3 V to -18 V
Analog Inputs ¹	$V_{SS} - 0.3\text{ V}$ to $V_{DD} + 0.3\text{ V}$ or 30 mA, whichever occurs first
Digital Inputs ¹	GND - 0.3 V to $V_{DD} + 0.3\text{ V}$ or 30 mA, whichever occurs first
Peak Current, S or D	850 mA (pulsed at 1 ms, 10% duty cycle maximum)
Continuous Current, S or D ²	Data + 15%
Operating Temperature Range	
Industrial (Y Version)	-40°C to +125°C
Storage Temperature Range	-65°C to +150°C
Junction Temperature	150°C
θ_{JA} Thermal Impedance	
16-Lead TSSOP (2-Layer Board)	150.4°C/W
16-Lead LFCSP (4-Layer Board)	48.7°C/W
Reflow Soldering Peak Temperature, Pb free	260°C

¹ Overvoltages at IN, S, or D are clamped by internal diodes. Current should be limited to the maximum ratings given.

² See Table 5.

Stresses at or above those listed under Absolute Maximum Ratings may cause permanent damage to the product. This is a stress rating only; functional operation of the product at these or any other conditions above those indicated in the operational section of this specification is not implied. Operation beyond the maximum operating conditions for extended periods may affect product reliability.

ESD CAUTION



ESD (electrostatic discharge) sensitive device.

Charged devices and circuit boards can discharge without detection. Although this product features patented or proprietary protection circuitry, damage may occur on devices subjected to high energy ESD. Therefore, proper ESD precautions should be taken to avoid performance degradation or loss of functionality.

PIN CONFIGURATIONS AND FUNCTION DESCRIPTIONS

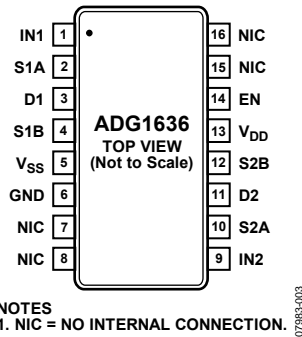

Figure 3. 16-Lead TSSOP Pin Configuration

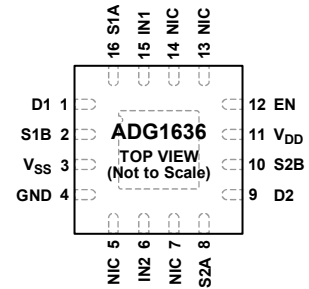

Figure 4. 16-Lead LFCSP Pin Configuration

Table 7. Pin Function Descriptions

Pin No.		Mnemonic	Description
TSSOP	LFCSP		
1	15	IN1	Logic Control Input.
2	16	S1A	Source Terminal. This pin can be an input or output.
3	1	D1	Drain Terminal. This pin can be an input or output.
4	2	S1B	Source Terminal. This pin can be an input or output.
5	3	V _{SS}	Most Negative Power Supply Potential.
6	4	GND	Ground (0 V) Reference.
7, 8, 15, 16	5, 7, 13, 14	NIC	No Internal Connection.
9	6	IN2	Logic Control Input.
10	8	S2A	Source Terminal. This pin can be an input or output.
11	9	D2	Drain Terminal. This pin can be an input or output.
12	10	S2B	Source Terminal. This pin can be an input or output.
13	11	V _{DD}	Most Positive Power Supply Potential.
14	12	EN	Active High Digital Input. When this pin is low, the device is disabled and all switches are off. When this pin is high, the Ax logic inputs determine the on switches.
N/A ¹	0	EPAD	Exposed Pad. Tie the exposed pad to the substrate, V _{SS} .

¹ N/A means not applicable.

Table 8. ADG1636 TSSOP Truth Table

EN	IN _x	S _x A	S _x B
0	X	Off	Off
1	0	Off	On
1	1	On	Off

Table 9. ADG1636 LFCSP Truth Table

EN	IN _x	S _x A	S _x B
0	X	Off	Off
1	0	Off	On
1	1	On	Off

TYPICAL PERFORMANCE CHARACTERISTICS

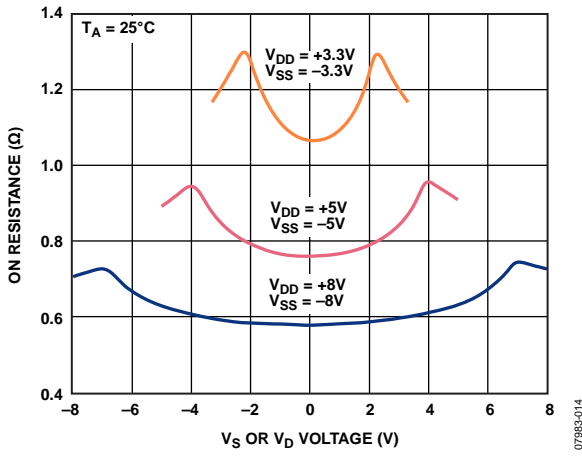

Figure 5. On Resistance as a Function of V_D (V_S) for Dual Supply

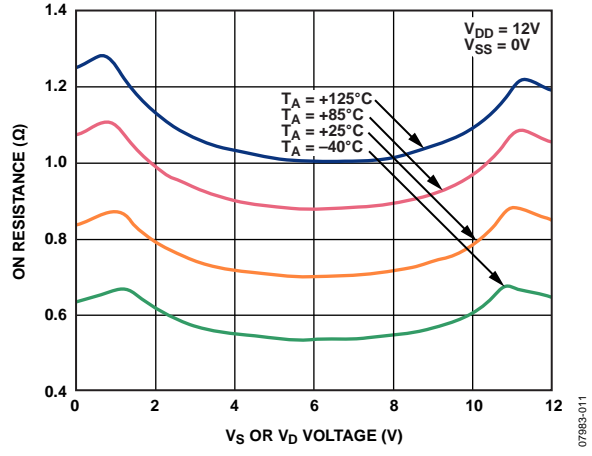

Figure 8. On Resistance as a Function of V_D (V_S) for Different Temperatures, 12 V Single Supply

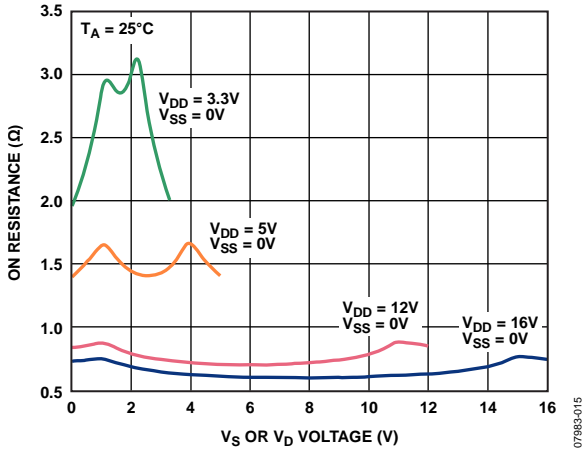

Figure 6. On Resistance as a Function of V_D (V_S) for Single Supply

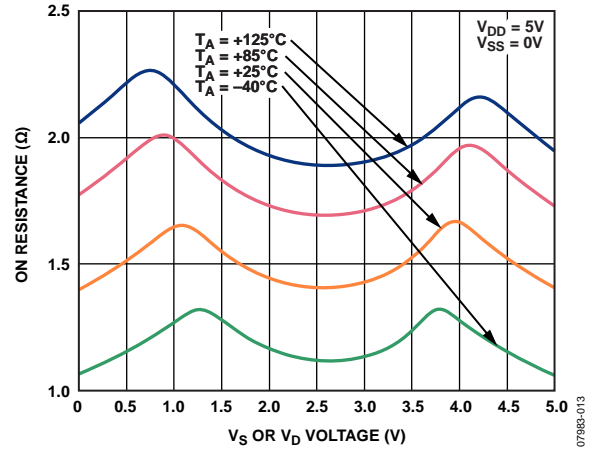

Figure 9. On Resistance as a Function of V_D (V_S) for Different Temperatures, 5 V Single Supply

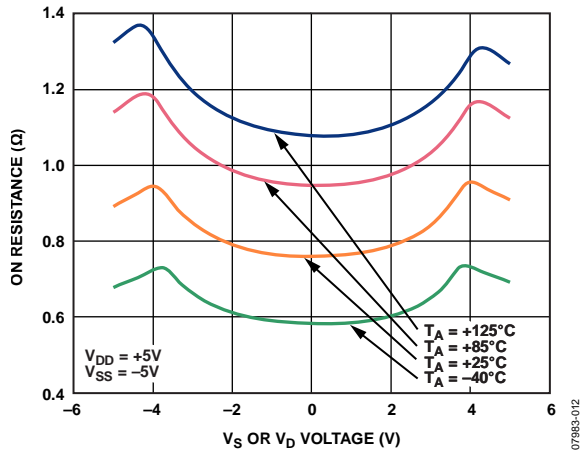

Figure 7. On Resistance as a Function of V_D (V_S) for Different Temperatures, ± 5 V Dual Supply

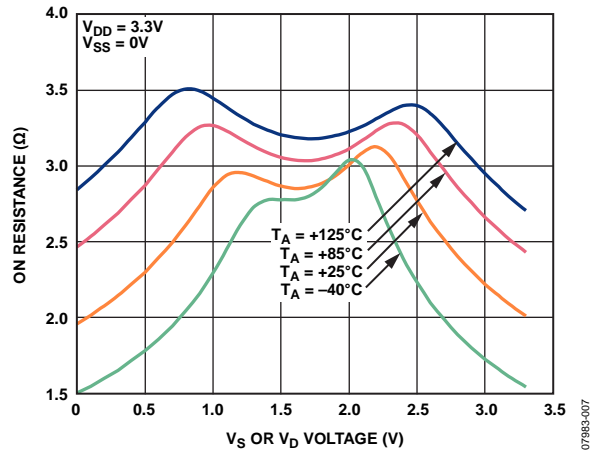

Figure 10. On Resistance as a Function of V_D (V_S) for Different Temperatures, 3.3 V Single Supply

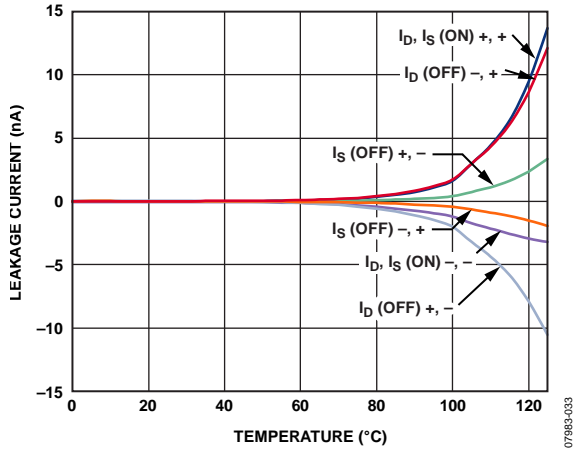

Figure 11. Leakage Currents as a Function of Temperature, ±5 V Dual Supply

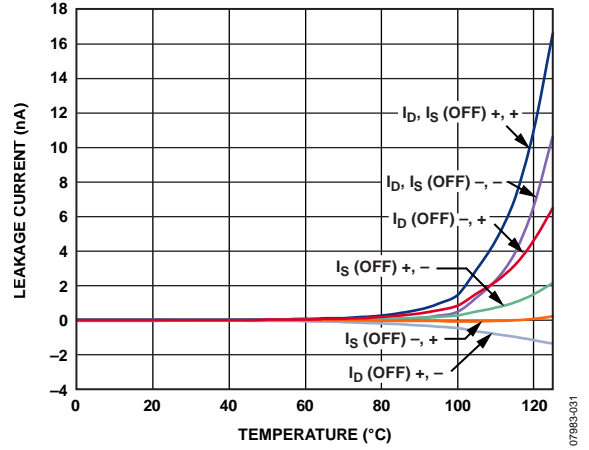

Figure 14. Leakage Currents as a Function of Temperature, 3.3 V Single Supply

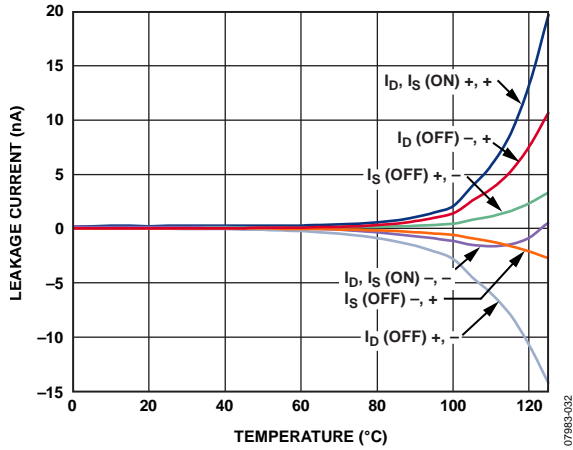

Figure 12. Leakage Currents as a Function of Temperature, 12 V Single Supply

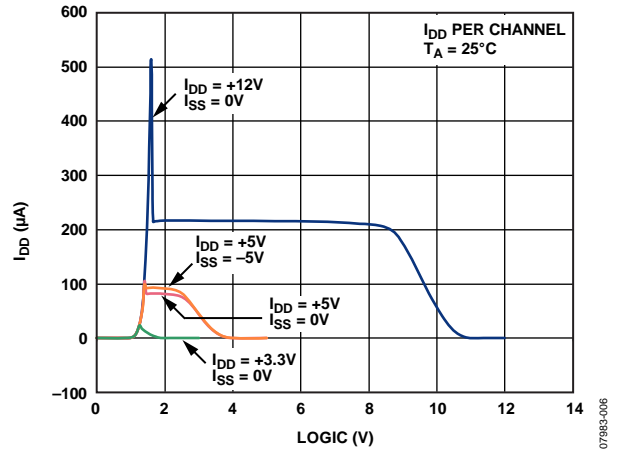

Figure 15. I_{DD} vs. Logic Level

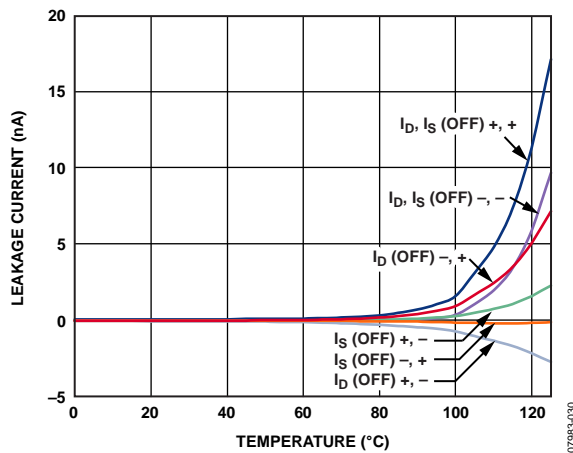

Figure 13. Leakage Currents as a Function of Temperature, 5 V Single Supply

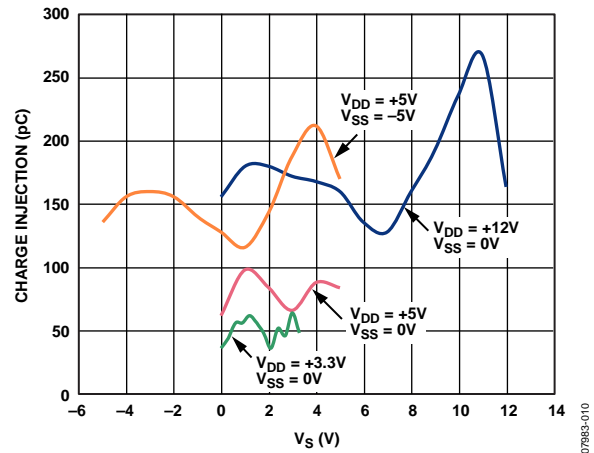

Figure 16. Charge Injection vs. Source Voltage

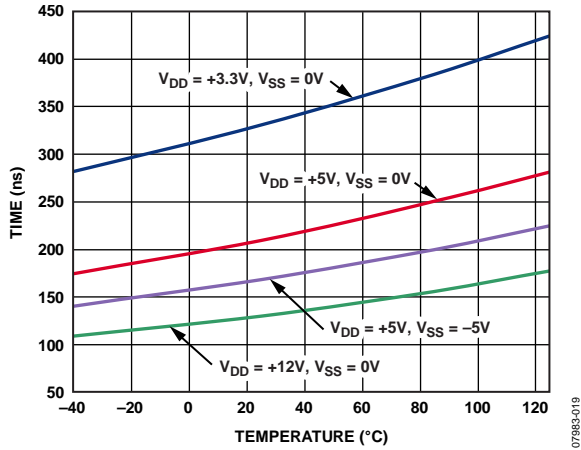

Figure 17. t_{ON}/t_{OFF} Times vs. Temperature

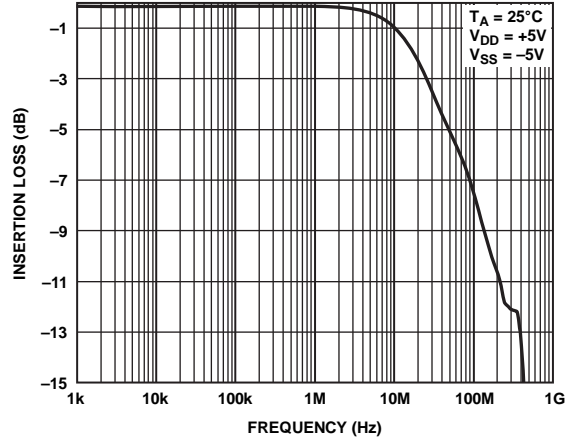

Figure 20. On Response vs. Frequency

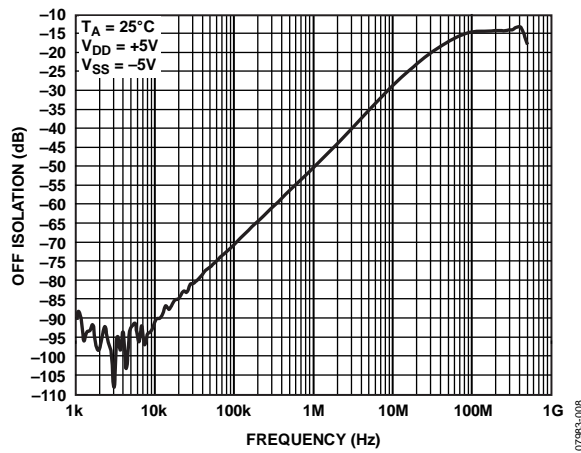

Figure 18. Off Isolation vs. Frequency

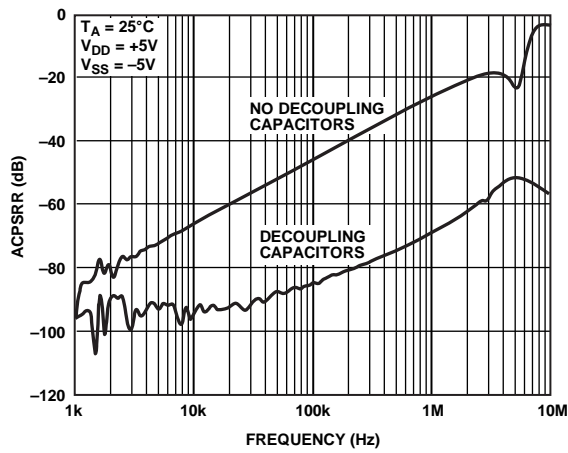

Figure 21. ACPSRR vs. Frequency

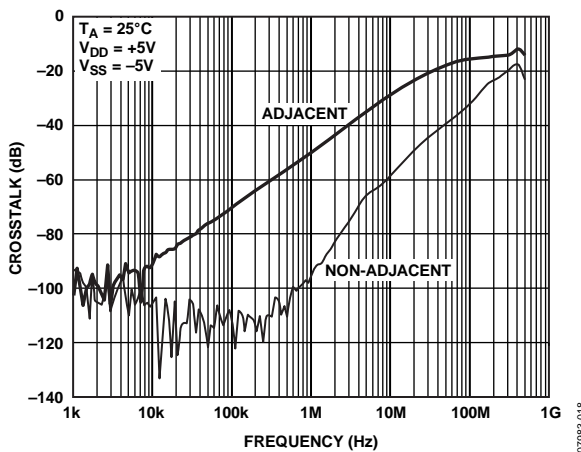

Figure 19. Crosstalk vs. Frequency

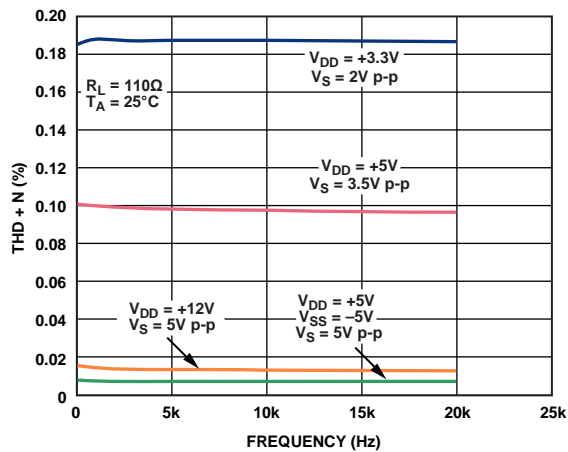

Figure 22. THD + N vs. Frequency

TEST CIRCUITS

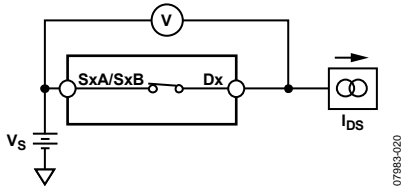

Figure 23. On Resistance

07985-020



Figure 24. Off Leakage

07983-021

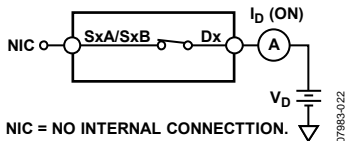

NIC = NO INTERNAL CONNECTION.
Figure 25. On Leakage

07983-022

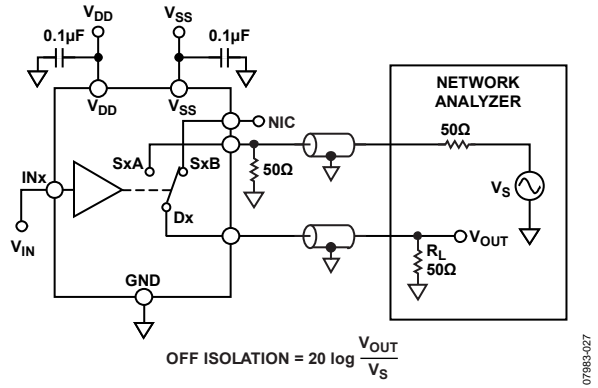

OFF ISOLATION = $20 \log \frac{V_{OUT}}{V_s}$
Figure 26. Off Isolation

07983-027

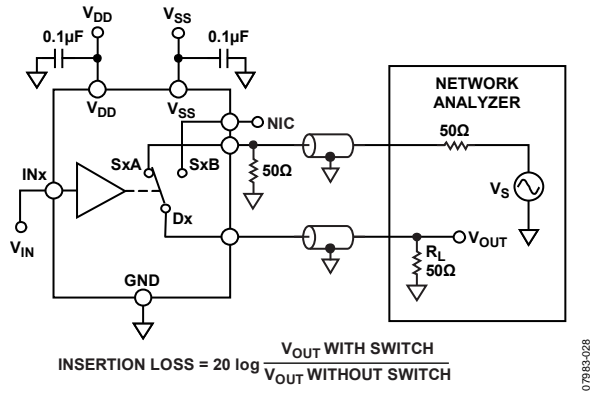

INSERTION LOSS = $20 \log \frac{V_{OUT \text{ WITH SWITCH}}}{V_{OUT \text{ WITHOUT SWITCH}}}$
Figure 27. Bandwidth

07983-028

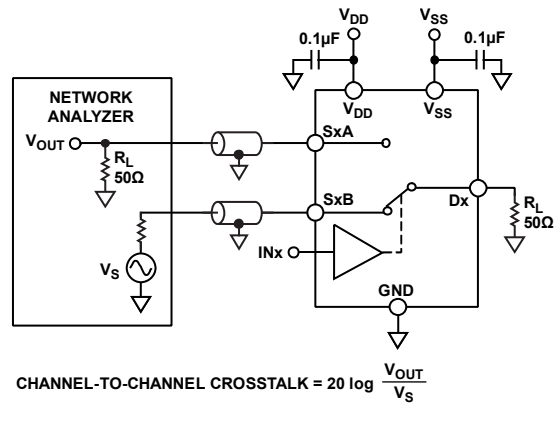

CHANNEL-TO-CHANNEL CROSSTALK = $20 \log \frac{V_{OUT}}{V_s}$
Figure 28. Channel-to-Channel Crosstalk

07985-029

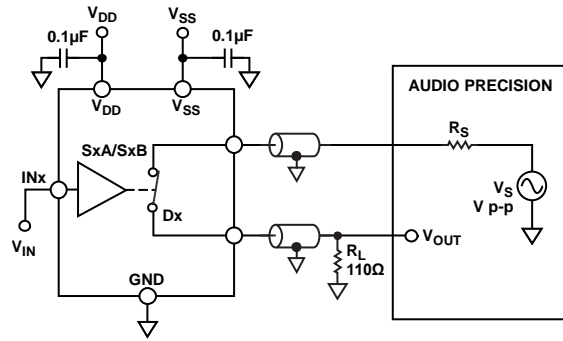

Figure 29. THD + Noise

07983-034

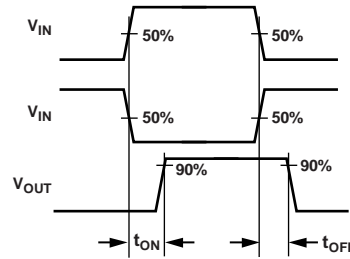
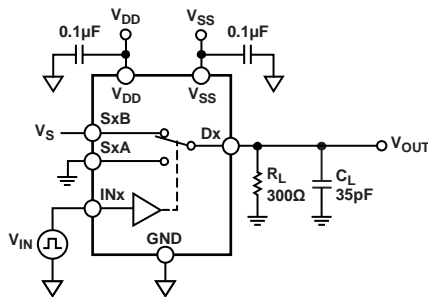

Figure 30. Switching Times

07983-023

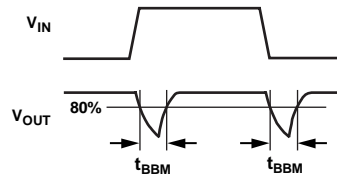
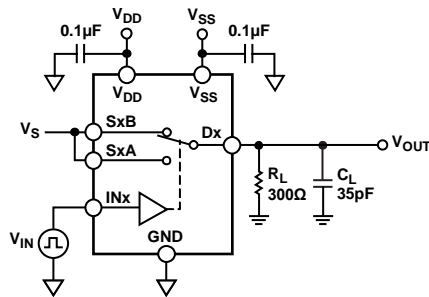

Figure 31. Break-Before-Make Time Delay

07983-024

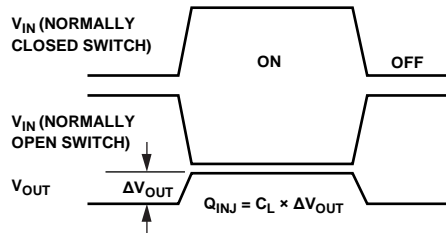
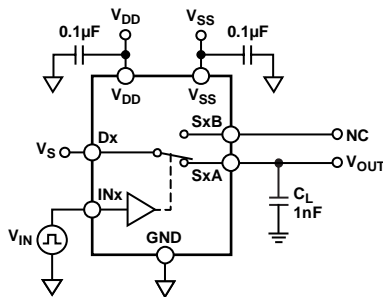

Figure 32. Charge Injection

07983-026

TERMINOLOGY

I_{DD}

The positive supply current.

I_{SS}

The negative supply current.

V_D (V_S)

The analog voltage on Terminal D and Terminal S.

R_{ON}

The ohmic resistance between Terminal D and Terminal S.

R_{FLAT(ON)}

Flatness that is defined as the difference between the maximum and minimum value of on resistance measured over the specified analog signal range.

I_S (Off)

The source leakage current with the switch off.

I_D (Off)

The drain leakage current with the switch off.

I_D, I_S (On)

The channel leakage current with the switch on.

V_{INL}

The maximum input voltage for Logic 0.

V_{INH}

The minimum input voltage for Logic 1.

I_{INL} (I_{INH})

The input current of the digital input.

C_S (Off)

The off switch source capacitance, which is measured with reference to ground.

C_D (Off)

The off switch drain capacitance, which is measured with reference to ground.

C_D, C_S (On)

The on switch capacitance, which is measured with reference to ground.

C_{IN}

The digital input capacitance.

t_{TRANSITION}

The delay time between the 50% and 90% points of the digital input and switch on condition when switching from one address state to another.

t_{ON} (EN)

The delay between applying the digital control input and the output switching on. See Figure 30.

t_{OFF} (EN)

The delay between applying the digital control input and the output switching off. See Figure 30.

Charge Injection

A measure of the glitch impulse transferred from the digital input to the analog output during switching.

Off Isolation

A measure of unwanted signal coupling through an off switch.

Crosstalk

A measure of unwanted signal that is coupled through from one channel to another as a result of parasitic capacitance.

Bandwidth

The frequency at which the output is attenuated by 3 dB.

On Response

The frequency response of the on switch.

Insertion Loss

The loss due to the on resistance of the switch.

Total Harmonic Distortion + Noise (THD + N)

The ratio of the harmonic amplitude plus noise of the signal to the fundamental.

AC Power Supply Rejection Ratio (ACPSRR)

The ratio of the amplitude of signal on the output to the amplitude of the modulation. This is a measure of the ability of the device to avoid coupling noise and spurious signals that appear on the supply voltage pin to the output of the switch. The dc voltage on the device is modulated by a sine wave of 0.62 V p-p.

OUTLINE DIMENSIONS

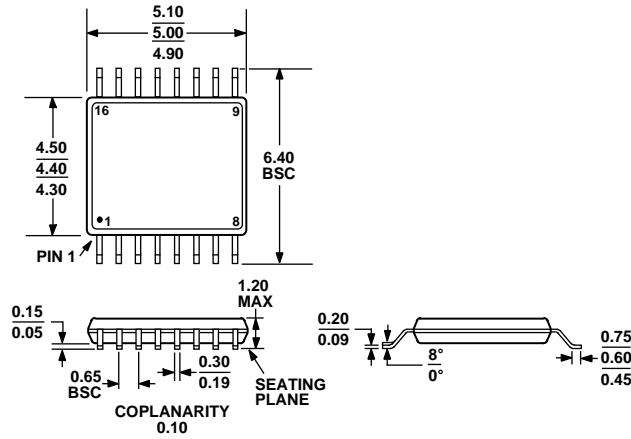

COMPLIANT TO JEDEC STANDARDS MO-153-AB

Figure 33. 16-Lead Thin Shrink Small Outline Package [TSSOP] (RU-16)

Dimensions shown in millimeters

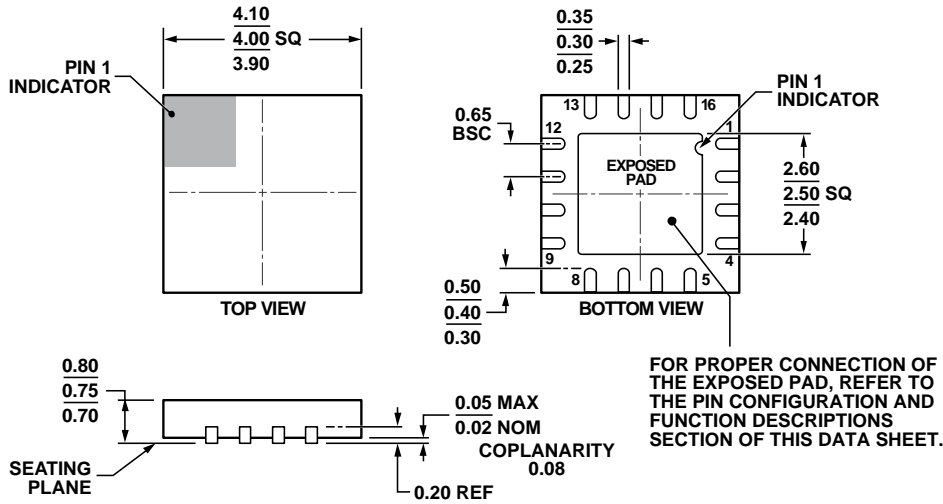

FOR PROPER CONNECTION OF THE EXPOSED PAD, REFER TO THE PIN CONFIGURATION AND FUNCTION DESCRIPTIONS SECTION OF THIS DATA SHEET.

COMPLIANT TO JEDEC STANDARDS MO-220-WGGC.

Figure 34. 16-Lead Lead Frame Chip Scale Package [LFCSOP] 4 mm x 4 mm Body and 0.75 mm Package Height (CP-16-26)

Dimensions shown in millimeters

ORDERING GUIDE

Model ¹	Temperature Range	Package Description	Package Option
ADG1636BRUZ	-40°C to +125°C	16-Lead Thin Shrink Small Outline Package [TSSOP]	RU-16
ADG1636BRUZ-REEL	-40°C to +125°C	16-Lead Thin Shrink Small Outline Package [TSSOP]	RU-16
ADG1636BRUZ-REEL7	-40°C to +125°C	16-Lead Thin Shrink Small Outline Package [TSSOP]	RU-16
ADG1636BCPZ-REEL	-40°C to +125°C	16-Lead Lead Frame Chip Scale Package [LFCSOP]	CP-16-26
ADG1636BCPZ-REEL7	-40°C to +125°C	16-Lead Lead Frame Chip Scale Package [LFCSOP]	CP-16-26

¹ Z = RoHS Compliant Part.

Looking for pricing, stock, or lifecycle information?

Click below to explore more details on WIN SOURCE:

 [View ADG1636BRUZ on WIN SOURCE](#)

 [Analog Devices Inc. Information](#)

Optimize Your Supply Chain with WIN SOURCE Solutions

-  Global Sourcing Solution
-  Obsolete Management
-  Cost Control Management
-  Shortage Management
-  Alternative Solution
-  Excess Inventory Management