



THE DATASHEET OF SS19L



SM72441 Programmable Maximum Power Point Tracking Controller for Photovoltaic Solar Panels

Check for Samples: [SM72441](#)

FEATURES

- Renewable Energy Grade
- Programmable Maximum Power Point Tracking
- Photovoltaic Solar Panel Voltage and Current Diagnostic
- Single Inductor Four Switch Buck-boost Converter Control
- VOUT Overvoltage Protection
- Over-Current Protection

PACKAGE

- TSSOP-28

Block Diagram

DESCRIPTION

The SM72441 is a programmable MPPT controller capable of controlling four PWM gate drive signals for a 4-switch buck-boost converter. Along with SM72295 (Photovoltaic Full Bridge Driver) it creates a solution for an MPPT configured DC-DC converter with efficiencies up to 98.5%. Integrated into the chip is an 8-channel, 12 bit A/D converter used to sense input and output voltage and current, as well as board configuration. Externally programmable values include maximum output voltage and current as well as different settings on slew rate, and soft-start.

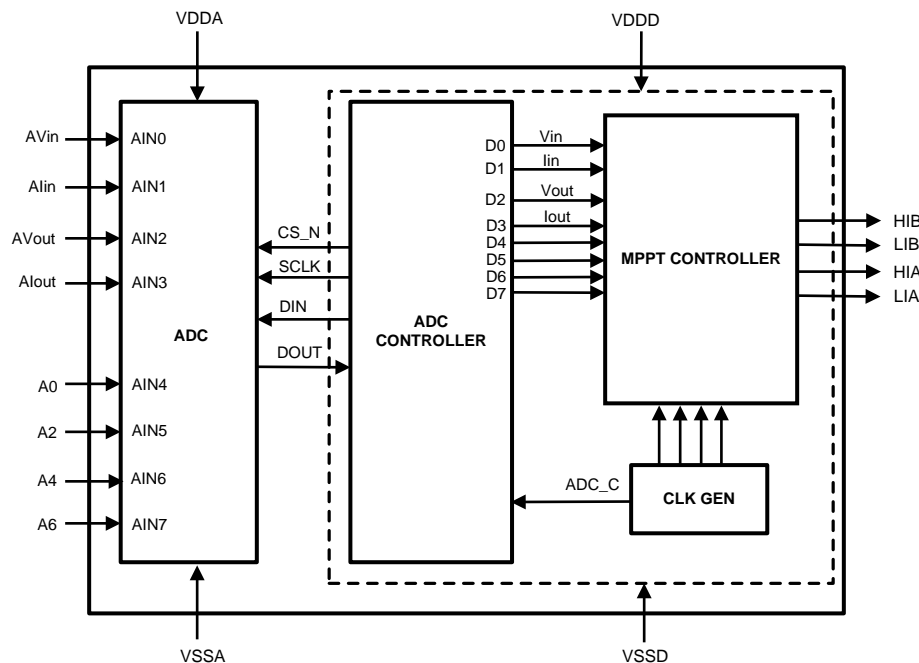

Figure 1. Block Diagram



Please be aware that an important notice concerning availability, standard warranty, and use in critical applications of Texas Instruments semiconductor products and disclaimers thereto appears at the end of this data sheet.

All trademarks are the property of their respective owners.

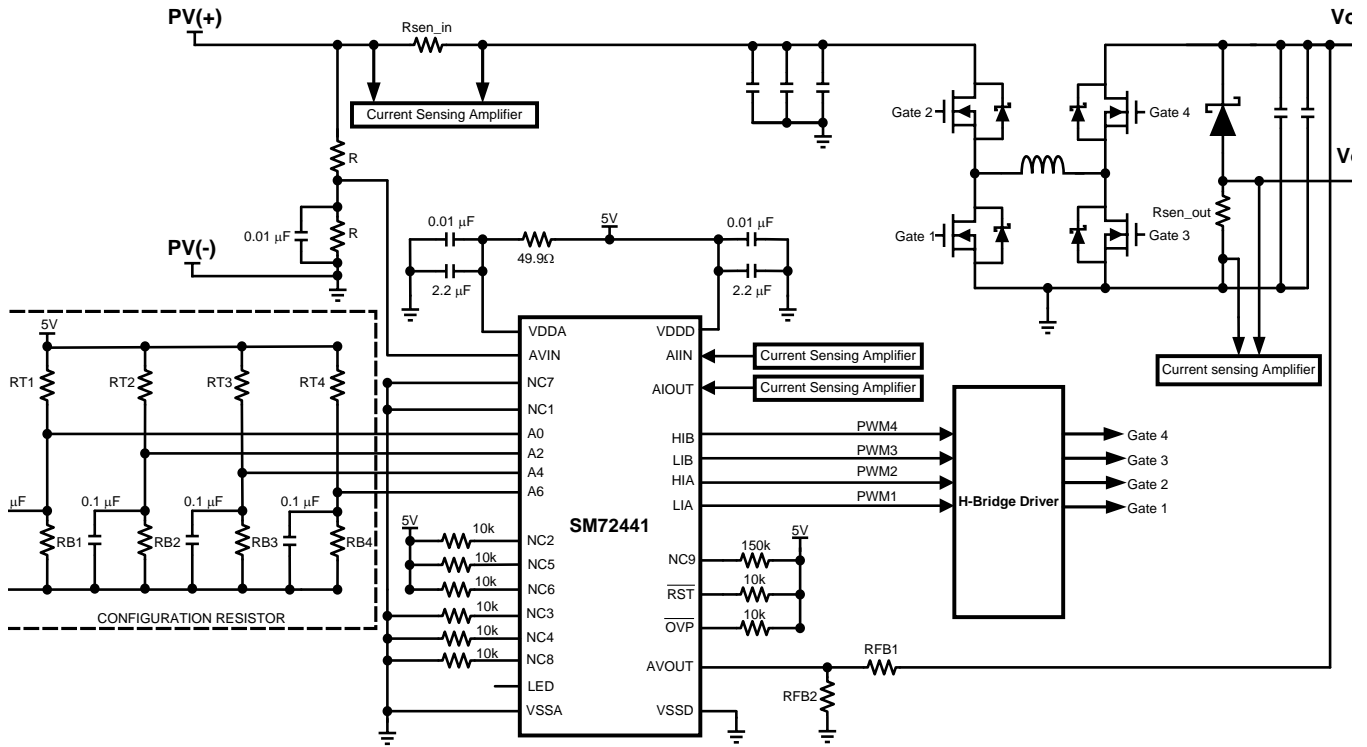

Figure 2. Typical Application Circuit

Connection Diagram

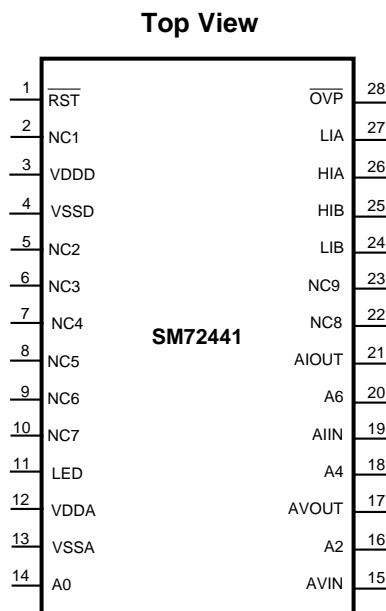

Figure 3. TSSOP-28 Package
See Package Drawing PW0028A

Pin Descriptions

Pin	Name	Description
1	$\overline{\text{RST}}$	Active low signal. External reset input signal to the digital circuit.
2	NC1	No Connect. This pin should be grounded.
3	VDDD	Digital supply voltage. This pin should be connected to a 5V supply, and bypassed to VSSD with a 0.1uF monolithic ceramic capacitor.
4	VSSD	Digital ground. The ground return for the digital supply and signals.
5	NC2	No Connect. This pin should be pulled up to the 5V supply using 10k resistor.
6	NC3	No Connect. This pin should be grounded using a 10k resistor.
7	NC4	No Connect. This pin should be grounded using a 10k resistor.
8	NC5	No Connect. This pin should be pulled up to 5V supply using 10k resistor.
9	NC6	No Connect. This pin should be pulled up to 5V supply using 10k resistor.
10	NC7	No Connect. This pin should be grounded.
11	LED	LED pin outputs a pulse during normal operation.
12	VDDA	Analog supply voltage. This voltage is also used as the reference voltage. This pin should be connected to a 5V supply, and bypassed to VSSA with a 1uF and 0.1uF monolithic ceramic capacitor.
13	VSSA	Analog ground. The ground return for the analog supply and signals.
14	A0	A/D Input Channel 0. Connect a resistor divider to 5V supply to set the maximum output voltage. Please refer to application section for more information on setting the resistor value.
15	AVIN	A/D Input to sense input voltage.
16	A2	A/D Input Channel 2. Connect a resistor divider to 5V supply to set MPPT update rate. Please refer to application section for more information on setting the resistor value.
17	AVOUT	A/D Input to sense the output voltage.
18	A4	A/D Input Channel 4. Connect a resistor divider to 5V supply to set the maximum output current. Please refer to application section for more information on setting the resistor value.
19	AIIN	A/D Input to sense input current.
20	A6	A/D Input Channel 6. Connect a resistor divider to 5V supply to set the maximum output voltage slew rate. Please refer to application section for more information on setting the resistor value.
21	AIOUT	A/D Input to sense the output current.

Pin Descriptions (continued)

Pin	Name	Description
22	NC8	No Connect. This pin should be grounded using a 10k resistor.
23	NC9	No Connect. This pin should be connected with 150k pull-up resistor to 5V supply.
24	LIB	Low side boost PWM output.
25	HIB	High side boost PWM output.
26	HIA	High side buck PWM output.
27	LIA	Low side buck PWM output.
28	$\overline{\text{OVP}}$	Overvoltage Protection Pin. Active Low. SM72441 will reset once voltage on this pin drops below its threshold voltage.



These devices have limited built-in ESD protection. The leads should be shorted together or the device placed in conductive foam during storage or handling to prevent electrostatic damage to the MOS gates.

Absolute Maximum Ratings⁽¹⁾⁽²⁾

Analog Supply Voltage V_A (VDDA -VSSA)		-0.3 to 6.0V
Analog Supply Voltage V_D (VDDD -VSSD)		-0.3 to $V_A + 0.3V$, max 6.0V
Voltage on Any Pin to GND		-0.3 to $V_A + 0.3V$
Input Current at Any Pin (Note 3)		± 10 mA
Package Input Current (Note 3)		± 20 mA
Storage Temperature Range		-65°C to +150°C
ESD Rating ⁽³⁾	Human Body Model	2 kV

- (1) Absolute Maximum Ratings indicate limits beyond which damage to the component may occur. Operating Ratings are conditions under which operation of the device is ensured. Operating Ratings indicate conditions for which the device is intended to be functional, but does not ensure specific performance limits. For specified performance limits and associated test conditions, see the Electrical Characteristics tables.
- (2) If Military/Aerospace specified devices are required, please contact the Texas Instruments Sales Office/ Distributors for availability and specifications.
- (3) The human body model is a 100 pF capacitor discharged through a 1.5 k Ω resistor into each pin.

Recommended Operating Conditions

Operating Temperature	-40°C to 105°C
V_A Supply Voltage	+4.75V to +5.25V
V_D Supply Voltage	+4.75V to V_A
Digital Input Voltage	0 to V_A
Analog Input Voltage	0 to V_A
Junction Temperature	-40°C to 125°C

Electrical Characteristics

Specifications in standard typeface are for $T_J = 25^\circ\text{C}$, and those in boldface type apply over the full operating junction temperature range.⁽¹⁾

Symbol	Parameter	Conditions	Min	Typ	Max	Units
ANALOG INPUT CHARACTERISTICS						
A_{Vin} , A_{Lin} A_{Vout} , A_{Lout}	Input Range		-	0 to V_A	-	V
I_{DCL}	DC Leakage Current		-	-	± 1	μA
C_{INA}	Input Capacitance ⁽²⁾	Track Mode	-	33	-	pF
		Hold Mode	-	3	-	pF
V_{ERR}	DC Voltage Measurement Accuracy			0.1		%
DIGITAL INPUT CHARACTERISTICS						
V_{IL}	Input Low Voltage		-	-	0.8	V
V_{IH}	Input High Voltage		2.8	-	-	V
C_{IND}	Digital Input Capacitance ⁽²⁾		-	2	4	pF
I_{IN}	Input Current		-	± 0.01	± 1	μA
DIGITAL OUTPUT CHARACTERISTICS						
V_{OH}	Output High Voltage	$I_{SOURCE} = 200 \mu\text{A}$ $V_A = V_D = 5\text{V}$	$V_D - 0.5$	-	-	V
V_{OL}	Output Low Voltage	$I_{SINK} = 200 \mu\text{A}$ to 1.0 mA $V_A = V_D = 5\text{V}$	-	-	0.4	V
I_{OZH} , I_{OZL}	Hi-Impedance Output Leakage Current	$V_A = V_D = 5\text{V}$			± 1	μA
C_{OUT}	Hi-Impedance Output Capacitance ⁽²⁾			2	4	pF
POWER SUPPLY CHARACTERISTICS ($C_L = 10 \text{ pF}$)						
V_A , V_D	Analog and Digital Supply Voltages	$V_A \geq V_D$	4.75	5	5.25	V
$I_A + I_D$	Total Supply Current	$V_A = V_D = 4.75\text{V}$ to 5.25V	7	10	15	mA
P_C	Power Consumption	$V_A = V_D = 4.75\text{V}$ to 5.25V		50	78	mW
PWM OUTPUT CHARACTERISTICS						
f_{PWM}	PWM switching frequency			210		kHz
t_{DEAD}	Dead time			38		ns

(1) Min and Max limits are 100% production tested at 25°C . Limits over the operating temperature range are specified through correlation using Statistical Quality Control (SQC) methods. Limits are used to calculate Texas Instrument's Average Outgoing Quality Level (AOQL).

(2) Not tested. Specified by design.

OPERATION DESCRIPTION

OVERVIEW

The SM72441 is a programmable MPPT controller capable of outputting four PWM gate drive signals for a 4-switch buck-boost converter. Refer to the Typical Application Circuit diagram (Figure 2).

The SM72441 uses an advanced digital controller to generate its PWM signals. A maximum power point tracking (MPPT) algorithm monitors the input current and voltage and controls the PWM duty cycle to maximize energy harvested from the photovoltaic module. MPPT performance is very fast. Convergence to the maximum power point of the module typically occurs within 0.01s. This enables the controller to maintain optimum performance under fast-changing irradiance conditions.

Transitions between buck, boost, and buck-boost modes are smoothed, and advanced digital PWM dithering techniques are employed to increase effective PWM resolution. Output voltage and current limiting functionality are integrated into the digital control logic. The controller is capable of handling both shorted and no-load conditions and will recover smoothly from both.

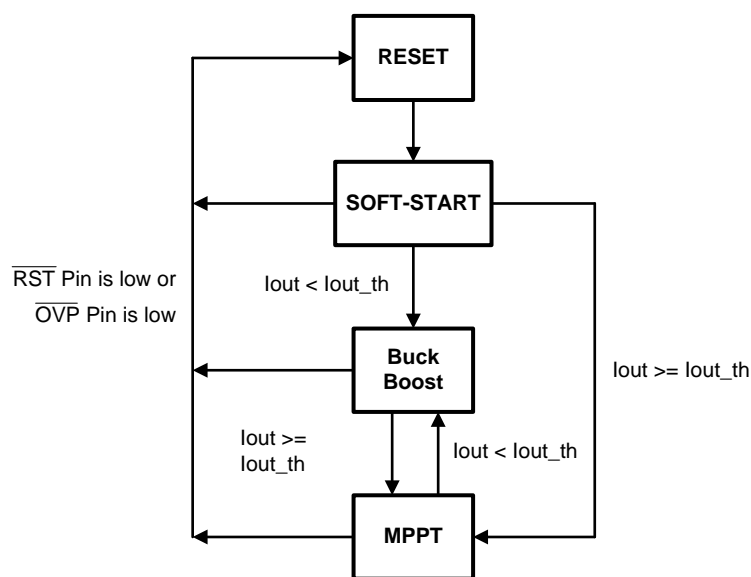

Figure 4. High Level State Diagram for Startup

STARTUP

SM72441 has a soft start feature that will ramp its output voltage for a fixed time of 250ms. MPPT mode will be entered during soft start if the load current exceeded the minimum current threshold. Otherwise, buck-boost operation is entered after soft-start is finished where the ratio between input and output voltage is 1:1. Refer to Figure 4 for a high level state diagram of startup. The current threshold to transition between MPPT to standby (buck-boost) mode and vice versa can be set by feeding the output of current sensing amplifier (Figure 2) to the AIIN and AIOU pin. For an appropriate voltage level, refer to the **AIIN AND AIOU PIN** section of this datasheet.

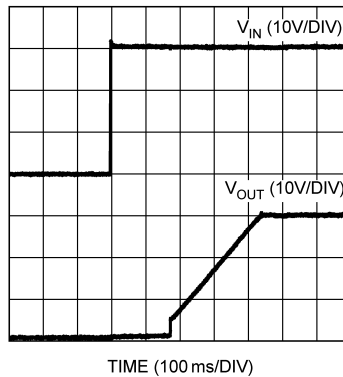

Figure 5. Start-Up Waveforms of Controlled Output

MAXIMUM OUTPUT VOLTAGE

Maximum output voltage on the SM72441 is set by resistor divider ratio on pin A0. (Please refer to [Figure 2](#) Typical Application Circuit).

$$V_{OUT_MAX} = 5 \times \frac{RB1}{RT1 + RB1} \times \frac{(RFB1 + RFB2)}{RFB2} \quad (1)$$

Where RT1 and RB1 are the resistor divider on the ADC pin A0 and RFB1 and RFB2 are the output voltage feedback resistors. A typical value for RFB2 is about 2 kΩ.

CURRENT LIMIT SETTING

Maximum output current can be set by changing the resistor divider on A4 (pin 18). (Refer to [Figure 2](#)). Overcurrent at the output is detected when the voltage on AIOUT (pin 21) equals to the voltage on A4 (pin 18). The voltage on A4 can be set by a resistor divider connected to 5V whereas a current sense amplifier output can be used to set the voltage on AIOUT.

AIIIN AND AIOUT PIN

These two pins are used to set current threshold from standby (buck-boost mode) to MPPT mode and from MPPT mode into standby mode.

In order to transition from standby to MPPT mode, the following conditions have to be satisfied:

- 1) AIIIN and AIOUT voltage > 0.488V
- 2) Iout < Iout_max

On the other hand, in order to transition from MPPT to standby mode, the following condition have to be satisfied:

- 1) AIIIN and AIOUT voltage < 0.293V
- 2) Iout < Iout_max

Current limit is triggered when AIOUT (pin 21) voltage is equal to A4 (pin 18).

AVIN PIN

AVIN pin is an A/D input to sense the input voltage of SM72441. A resistor divider can be used to scale the max voltage to about 4V, which is 80% of the full scale of the A/D input.

CONFIGURABLE SETTINGS

The voltage on A0 sets the max output voltage; whereas the voltage on A2 enables MPPT update rate and limits the max boost ratio when output current is below the standby threshold. Output current limit is set by the voltage on A4 and output voltage slew rate limit is set on A6. In order to set a slew rate limit of 125V/sec, the ratio of the two resistors in A6 should be 9:1.

The low current condition is detected if the voltage on AIIN is less than 0.488V (rising) and 0.293 (falling) + ΔI or if the voltage on AIOU is less than 0.488 V (rising) and 0.293 (falling) + ΔI . If low current is detected, the converter operates in standby mode and limit the maximum duty cycle to either a 1 (buck-boost), 1.15 (boost) or 1.25 (boost) conversion ratio (programmable). In this case no MPPT will be performed.

The actual value of current will depend on the gain of the current sensing amplifier circuitry that feeds the AIIN and AIOU pins.

For more complete information on the various settings based on the voltage level of A2, please refer to [Table 1](#) below. Vfs denotes the full scale voltage of the ADC which is equal to VDDA where VDDA is a reference voltage to analog ground.

A typical value for top configuration resistors (RT1 to RT4) should be 20 k Ω .

Table 1. List of Configurable Modes on ADC Channel 2

ADC Channel 2	MPPT Update Time	Slew Rate Detection	Low Current Detection	Initial Boost Ratio	Delta I
$0 < V_{ADC2} < V_{fs}/16$	1.2 ms	Disabled	Disabled	N/A	N/A
$1V_{fs}/16 < V_{ADC2} < 2V_{fs}/16$	38 ms	Disabled	Disabled	N/A	N/A
$2V_{fs}/16 < V_{ADC2} < 3V_{fs}/16$	77 ms	Disabled	Disabled	N/A	N/A
$3V_{fs}/16 < V_{ADC2} < 4V_{fs}/16$	38 ms	Enabled	Disabled	N/A	N/A
$4V_{fs}/16 < V_{ADC2} < 5V_{fs}/16$	38 ms	Enabled	Enabled	1.15	60 (0.3 A)
$5V_{fs}/16 < V_{ADC2} < 6V_{fs}/16$	38 ms	Enabled	Enabled	1.15	90 (0.45 A)
$6V_{fs}/16 < V_{ADC2} < 7V_{fs}/16$	38 ms	Enabled	Enabled	1.15	120(0.6 A)
$7V_{fs}/16 < V_{ADC2} < 8V_{fs}/16$	38 ms	Enabled	Enabled	1.25	60
$8V_{fs}/16 < V_{ADC2} < 9V_{fs}/16$	38 ms	Enabled	Enabled	1.25	90
$9V_{fs}/16 < V_{ADC2} < 10V_{fs}/16$	38 ms	Enabled	Enabled	1.25	120
$10V_{fs}/16 < V_{ADC2} < 11V_{fs}/16$	77 ms	Enabled	Enabled	1.15	60
$11V_{fs}/16 < V_{ADC2} < 12V_{fs}/16$	77 ms	Enabled	Enabled	1.15	90
$12V_{fs}/16 < V_{ADC2} < 13V_{fs}/16$	77 ms	Enabled	Enabled	1.15	120
$13V_{fs}/16 < V_{ADC2} < 14V_{fs}/16$	77 ms	Enabled	Enabled	1.25	60
$14V_{fs}/16 < V_{ADC2} < 15V_{fs}/16$	77 ms	Enabled	Enabled	1.25	90
$15V_{fs}/16 < V_{ADC2} < 16V_{fs}/16$	77 ms	Enabled	Enabled	1.25	120

RESET PIN

When the reset pin is pulled low, the chip will cease its normal operation and turn-off all of its PWM outputs. Below is an oscilloscope capture of a forced reset condition.

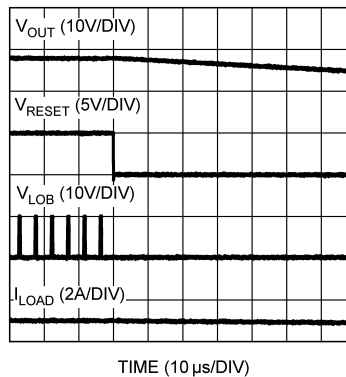

Figure 6. Reset Operational Behavior

As seen in Figure 6, the initial value for output voltage and load current are 28V and 1A respectively. After the reset pin is grounded, both the output voltage and load current decreases immediately. MOSFET switching on the buck-boost converter also stops immediately. V_{LOB} indicates the low side boost output from the SM72295.

ANALOG INPUT

An equivalent circuit for one of the ADC input channels is shown in Figure 7. Diode D1 and D2 provide ESD protection for the analog inputs. The operating range for the analog inputs is 0V to V_A . Going beyond this range will cause the ESD diodes to conduct and result in erratic operation.

The capacitor C1 in Figure 7 has a typical value of 3 pF and is mainly the package pin capacitance. Resistor R1 is the on resistance of the multiplexer and track / hold switch; it is typically 500Ω. Capacitor C2 is the ADC sampling capacitor; it is typically 30 pF. The ADC will deliver best performance when driven by a low-impedance source (less than 100Ω). This is especially important when sampling dynamic signals. Also important when sampling dynamic signals is a band-pass or low-pass filter which reduces harmonic and noise in the input. These filters are often referred to as anti-aliasing filters.

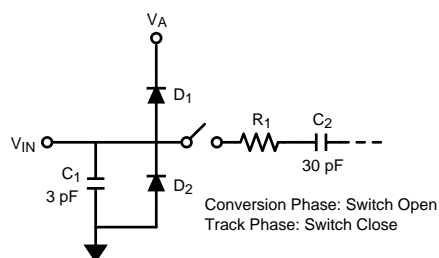

Figure 7. Equivalent Input Circuit

DIGITAL INPUTS AND OUTPUTS

The digital input signals have an operating range of 0V to V_A , where $V_A = V_{DDA} - V_{SSA}$. They are not prone to latch-up and may be asserted before the digital supply V_D , where $V_D = V_{DDD} - V_{SSD}$, without any risk. The digital output signals operating range is controlled by V_D . The output high voltage is $V_D - 0.5V$ (min) while the output low voltage is 0.4V (max).

REVISION HISTORY

Changes from Revision F (April 2013) to Revision G	Page
• Changed layout of National Data Sheet to TI format	9

PACKAGING INFORMATION

Orderable Device	Status (1)	Package Type	Package Drawing	Pins	Package Qty	Eco Plan (2)	Lead finish/ Ball material (6)	MSL Peak Temp (3)	Op Temp (°C)	Device Marking (4/5)	Samples
SM72441MT/NOPB	ACTIVE	TSSOP	PW	28	48	RoHS & Green	SN	Level-3-260C-168 HR	-40 to 105	S72441	Samples
SM72441MTE/NOPB	ACTIVE	TSSOP	PW	28	250	RoHS & Green	SN	Level-3-260C-168 HR	-40 to 105	S72441	Samples
SM72441MTX/NOPB	ACTIVE	TSSOP	PW	28	2500	RoHS & Green	SN	Level-3-260C-168 HR	-40 to 105	S72441	Samples

(1) The marketing status values are defined as follows:

ACTIVE: Product device recommended for new designs.

LIFEBUY: TI has announced that the device will be discontinued, and a lifetime-buy period is in effect.

NRND: Not recommended for new designs. Device is in production to support existing customers, but TI does not recommend using this part in a new design.

PREVIEW: Device has been announced but is not in production. Samples may or may not be available.

OBSOLETE: TI has discontinued the production of the device.

(2) **RoHS:** TI defines "RoHS" to mean semiconductor products that are compliant with the current EU RoHS requirements for all 10 RoHS substances, including the requirement that RoHS substance do not exceed 0.1% by weight in homogeneous materials. Where designed to be soldered at high temperatures, "RoHS" products are suitable for use in specified lead-free processes. TI may reference these types of products as "Pb-Free".

RoHS Exempt: TI defines "RoHS Exempt" to mean products that contain lead but are compliant with EU RoHS pursuant to a specific EU RoHS exemption.

Green: TI defines "Green" to mean the content of Chlorine (Cl) and Bromine (Br) based flame retardants meet JS709B low halogen requirements of <=1000ppm threshold. Antimony trioxide based flame retardants must also meet the <=1000ppm threshold requirement.

(3) MSL, Peak Temp. - The Moisture Sensitivity Level rating according to the JEDEC industry standard classifications, and peak solder temperature.

(4) There may be additional marking, which relates to the logo, the lot trace code information, or the environmental category on the device.

(5) Multiple Device Markings will be inside parentheses. Only one Device Marking contained in parentheses and separated by a "~" will appear on a device. If a line is indented then it is a continuation of the previous line and the two combined represent the entire Device Marking for that device.

(6) Lead finish/Ball material - Orderable Devices may have multiple material finish options. Finish options are separated by a vertical ruled line. Lead finish/Ball material values may wrap to two lines if the finish value exceeds the maximum column width.

Important Information and Disclaimer:The information provided on this page represents TI's knowledge and belief as of the date that it is provided. TI bases its knowledge and belief on information provided by third parties, and makes no representation or warranty as to the accuracy of such information. Efforts are underway to better integrate information from third parties. TI has taken and continues to take reasonable steps to provide representative and accurate information but may not have conducted destructive testing or chemical analysis on incoming materials and chemicals. TI and TI suppliers consider certain information to be proprietary, and thus CAS numbers and other limited information may not be available for release.

In no event shall TI's liability arising out of such information exceed the total purchase price of the TI part(s) at issue in this document sold by TI to Customer on an annual basis.

TAPE AND REEL INFORMATION

QUADRANT ASSIGNMENTS FOR PIN 1 ORIENTATION IN TAPE

*All dimensions are nominal

Device	Package Type	Package Drawing	Pins	SPQ	Reel Diameter (mm)	Reel Width W1 (mm)	A0 (mm)	B0 (mm)	K0 (mm)	P1 (mm)	W (mm)	Pin1 Quadrant
SM72441MTE/NOPB	TSSOP	PW	28	250	178.0	16.4	6.8	10.2	1.6	8.0	16.0	Q1
SM72441MTX/NOPB	TSSOP	PW	28	2500	330.0	16.4	6.8	10.2	1.6	8.0	16.0	Q1

TAPE AND REEL BOX DIMENSIONS

*All dimensions are nominal

Device	Package Type	Package Drawing	Pins	SPQ	Length (mm)	Width (mm)	Height (mm)
SM72441MTE/NOPB	TSSOP	PW	28	250	208.0	191.0	35.0
SM72441MTX/NOPB	TSSOP	PW	28	2500	356.0	356.0	36.0

TUBE



*All dimensions are nominal

Device	Package Name	Package Type	Pins	SPQ	L (mm)	W (mm)	T (μm)	B (mm)
SM72441MT/NOPB	PW	TSSOP	28	48	495	8	2514.6	4.06

MECHANICAL DATA

PW (R-PDSO-G28)

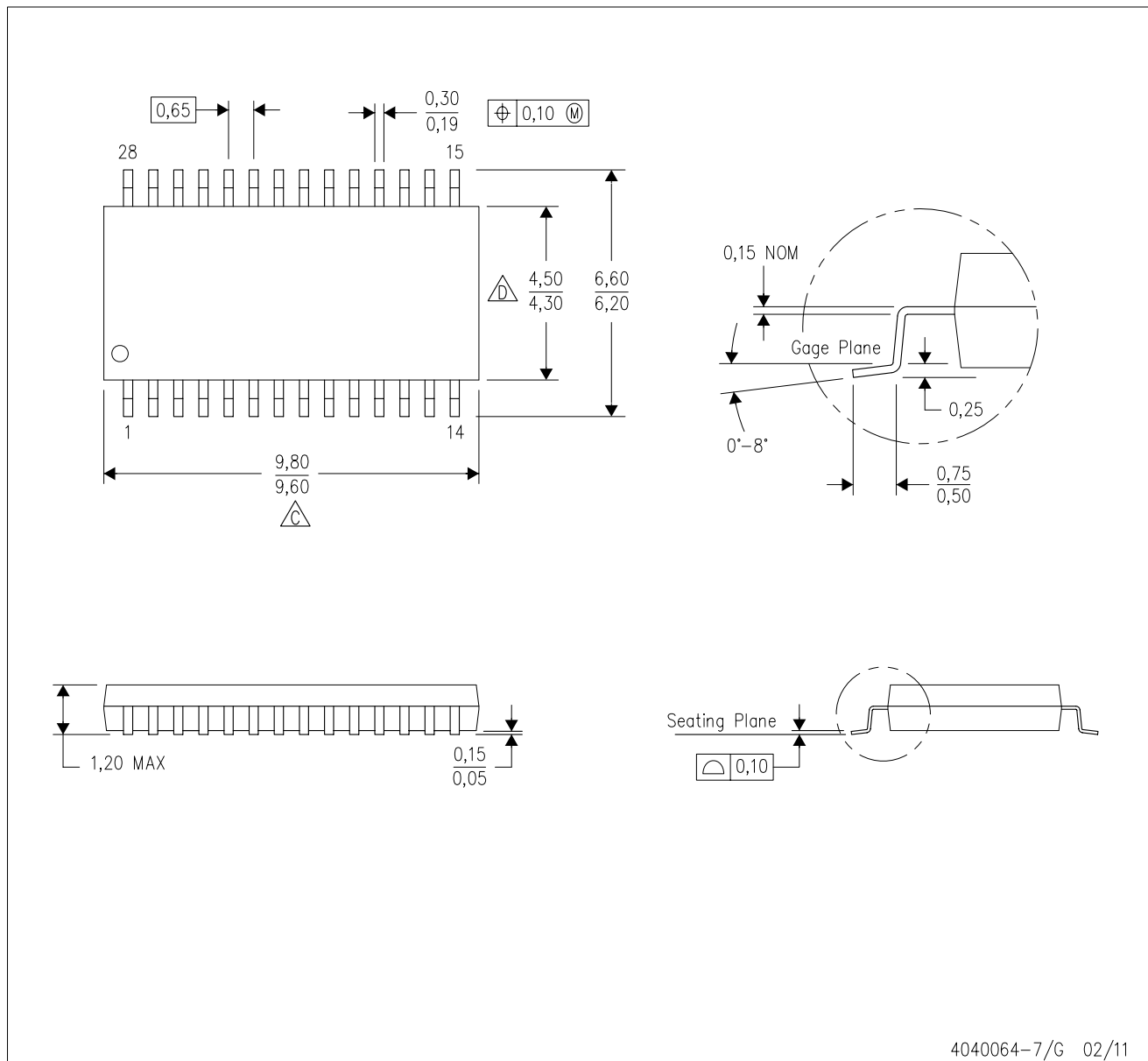
PLASTIC SMALL OUTLINE



4040064-7/G 02/11

- NOTES:
- A. All linear dimensions are in millimeters. Dimensioning and tolerancing per ASME Y14.5M-1994.
 - B. This drawing is subject to change without notice.
 - C. Body length does not include mold flash, protrusions, or gate burrs. Mold flash, protrusions, or gate burrs shall not exceed 0,15 each side.
 - D. Body width does not include interlead flash. Interlead flash shall not exceed 0,25 each side.
 - E. Falls within JEDEC MO-153

IMPORTANT NOTICE AND DISCLAIMER

TI PROVIDES TECHNICAL AND RELIABILITY DATA (INCLUDING DATA SHEETS), DESIGN RESOURCES (INCLUDING REFERENCE DESIGNS), APPLICATION OR OTHER DESIGN ADVICE, WEB TOOLS, SAFETY INFORMATION, AND OTHER RESOURCES "AS IS" AND WITH ALL FAULTS, AND DISCLAIMS ALL WARRANTIES, EXPRESS AND IMPLIED, INCLUDING WITHOUT LIMITATION ANY IMPLIED WARRANTIES OF MERCHANTABILITY, FITNESS FOR A PARTICULAR PURPOSE OR NON-INFRINGEMENT OF THIRD PARTY INTELLECTUAL PROPERTY RIGHTS.

These resources are intended for skilled developers designing with TI products. You are solely responsible for (1) selecting the appropriate TI products for your application, (2) designing, validating and testing your application, and (3) ensuring your application meets applicable standards, and any other safety, security, regulatory or other requirements.

These resources are subject to change without notice. TI grants you permission to use these resources only for development of an application that uses the TI products described in the resource. Other reproduction and display of these resources is prohibited. No license is granted to any other TI intellectual property right or to any third party intellectual property right. TI disclaims responsibility for, and you will fully indemnify TI and its representatives against, any claims, damages, costs, losses, and liabilities arising out of your use of these resources.



TI's products are provided subject to [TI's Terms of Sale](#) or other applicable terms available either on [ti.com](https://www.ti.com) or provided in conjunction with such TI products. TI's provision of these resources does not expand or otherwise alter TI's applicable warranties or warranty disclaimers for TI products.

TI objects to and rejects any additional or different terms you may have proposed.

Mailing Address: Texas Instruments, Post Office Box 655303, Dallas, Texas 75265
Copyright © 2024, Texas Instruments Incorporated

Looking for pricing, stock, or lifecycle information?

Click below to explore more details on WIN SOURCE:

-  [View SS19L on WIN SOURCE](#)
-  [Taiwan Semiconductor Information](#)

Optimize Your Supply Chain with WIN SOURCE Solutions

-  Global Sourcing Solution
-  Obsolete Management
-  Cost Control Management
-  Shortage Management
-  Alternative Solution
-  Excess Inventory Management