



THE DATASHEET OF HS2G



Features

- Glass passivated junction chip
- For surface mount applications
- Low forward voltage drop
- Low profile package
- Built-in stain relief, ideal for automated placement
- Fast switching for high efficiency
- Plastic package has Underwriters Laboratory Flammability Classification 94V-0
- Weight: 0.003 ounce,0.093 gram

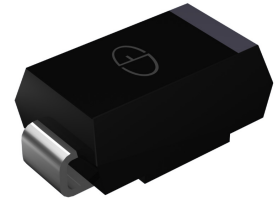

Package: DO-214AA (SMB)



Applications

For use of general purpose rectifications in lighting, cellular phones, portable devices, power supplies and other consumer applications.

Maximum Ratings (T_A = 25°C unless otherwise noted)

Parameter	Symbol	HS2A	HS2B	HS2D	HS2F	HS2G	HS2J	HS2K	HS2M	Unit
Maximum Repetitive Peak Reverse Voltage	V _{RRM}	50	100	200	300	400	600	800	1000	V
Maximum RMS Voltage	V _{RMS}	35	70	140	210	280	420	560	700	V
Maximum DC Blocking Voltage	V _{DC}	50	100	200	300	400	600	800	1000	V
Maximum Average Output Rectified Current	I _{F(AV)}	1.5								A
Peak Forward Surge Current (8.3 ms single half sine-wave superimposed on rated load)	I _{FSM}	50								A
Rating for Fusing (t<8.3ms)	I ² t	10								A ² sec
Operating Junction and Storage Temperature Range	T _J , T _{STG}	-55 to +150								°C

Electrical Characteristics (T_A = 25°C unless otherwise noted)

Parameter	Test Conditions	Symbol	HS2A	HS2B	HS2D	HS2F	HS2G	HS2J	HS2K	HS2M	Unit
Maximum Instantaneous Forward Voltage	I _F =1.5A	V _F	1.0				1.3	1.7			V
Maximum DC Reverse Current at Rated DC Blocking Voltage	T _A =25°C T _A =125°C	I _R	5.0				100				μA
Maximum Reverse Recovery Time	I _F =0.5A, I _R =1.0A, I _{RR} =0.25A	t _{rr}	50				75				ns
Typical Junction Capacitance	4.0 V, 1 MHz	C _J	50				30				pF

Thermal Characteristics

Parameter	Symbol	HS2A	HS2B	HS2D	HS2F	HS2G	HS2J	HS2K	HS2M	Unit
Typical thermal resistance ⁽¹⁾	R _{θJA}	54								°C/W
	R _{θJC}	16								
	R _{θJI}	7								

Notes:1. The thermal resistance from junction to ambient,case or mount,mounted on P.C.B with 8×8mm copper pads,2 OZ,FR4 PCB

Ratings and Characteristics Curves ($T_A = 25^\circ\text{C}$ unless otherwise noted)

FIG.1- REVERSE RECOVERY TIME CHARACTERISTIC AND TEST CIRCUIT DIAGRAM

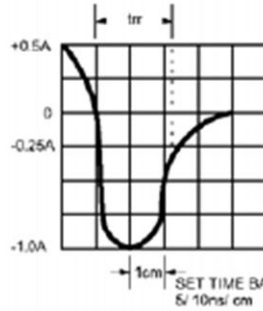
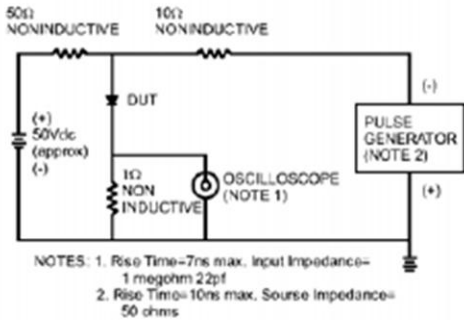

FIG.2- MAXIMUM FORWARD CURRENT DERATING CURVE

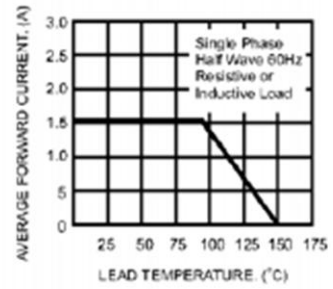

FIG.3- TYPICAL REVERSE CHARACTERISTICS

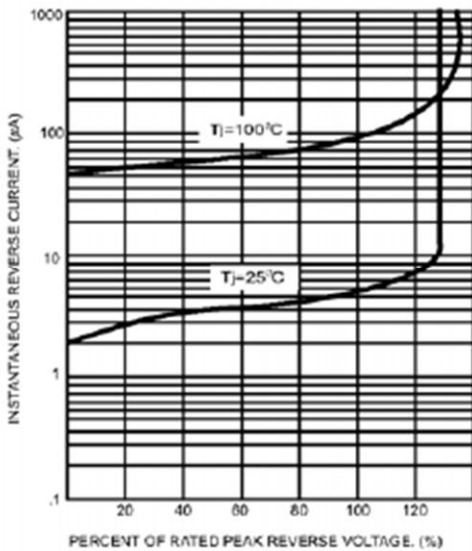

FIG.4- TYPICAL INSTANTANEOUS FORWARD CHARACTERISTICS

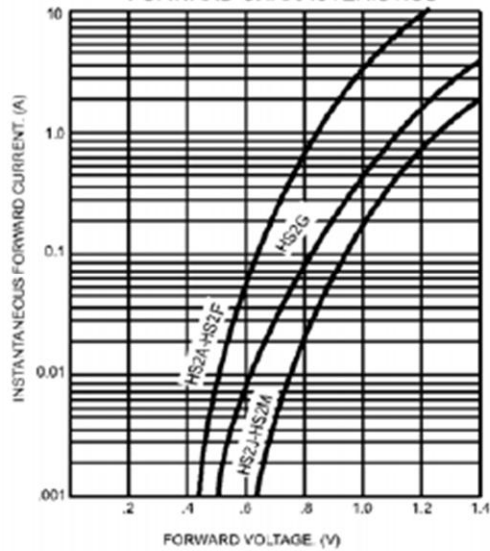

FIG.5- MAXIMUM NON-REPETITIVE FORWARD SURGE CURRENT

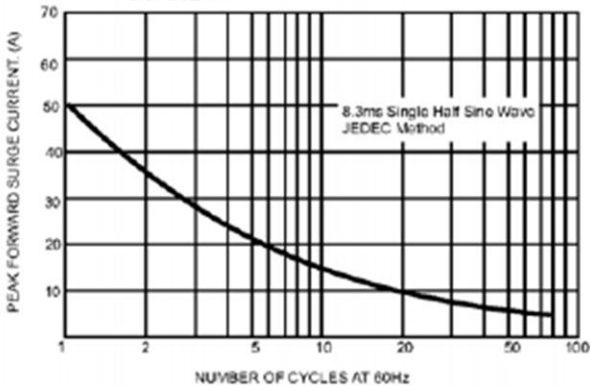
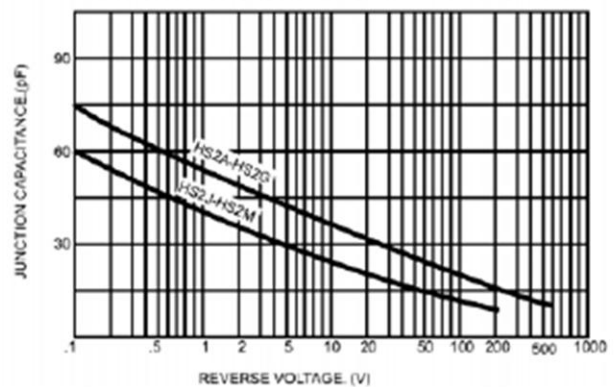

FIG.6- TYPICAL JUNCTION CAPACITANCE



Package Outline Dimensions

in inches (millimeters)

SMB (DO-214AA)

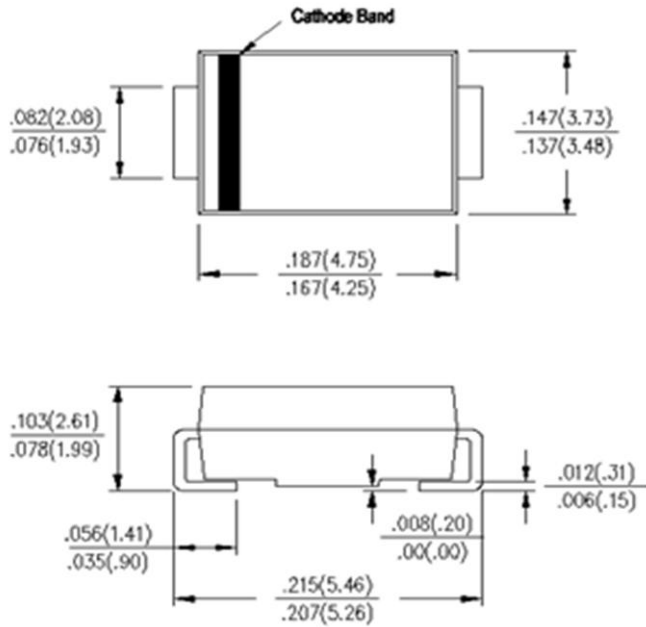

Mounting Pad Layout

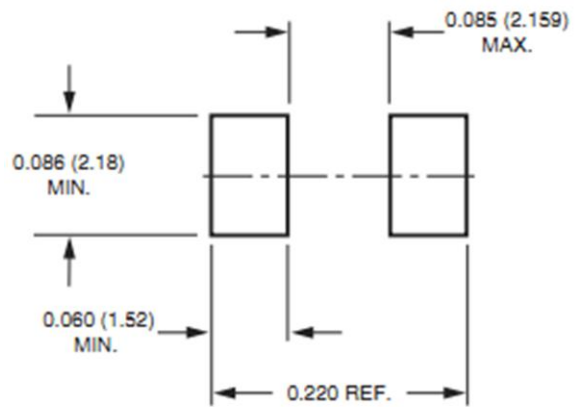

Packing Information

3000 pcs/Reel, 18 Reels/Box; 12mm Tape, 13" Reel

Tape & Reel Specification

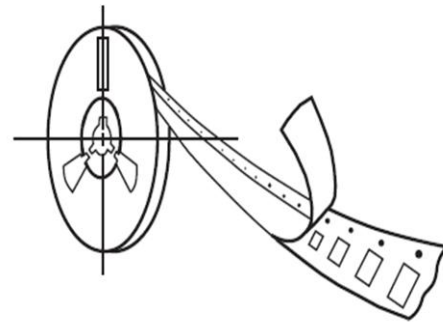
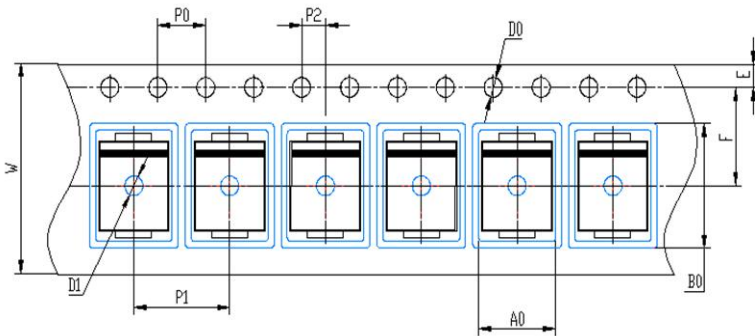

Symbol	SMB(mm)
W	12±0.2
E	1.75±0.1
F	5.5±0.05
D0	1.5±0.1
D1	1.50 +0.1/-0
P0	4.0±0.1
P1	8.0±0.1
P2	2.0±0.05
A0	3.95±0.1
B0	5.74±0.1

Soldering Parameters

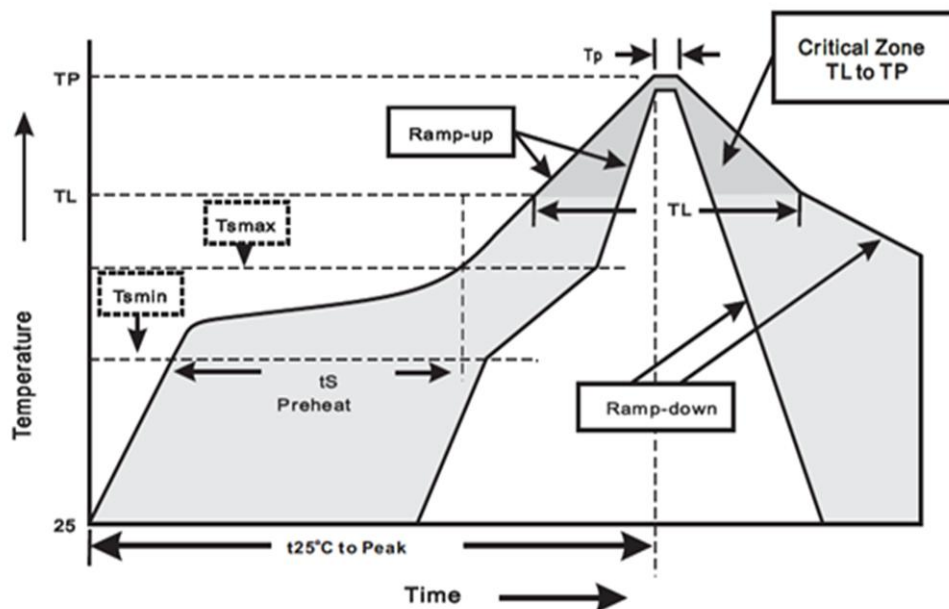

Reflow Condition		Lead-free assembly
Pre Heat	- Temperature Min (Ts(min))	150°C
	- Temperature Max (Ts(max))	200°C
	- Time (min to max) (ts)	60 – 180 secs
Average ramp up rate (Liquidus Temp (TL) to peak)		3°C/second max
TS(max) to TL - Ramp-up Rate		3°C/second max
Reflow	- Temperature (TL) (Liquidus)	217°C
	- Time (min to max) (ts)	60 – 150 seconds
Peak Temperature (TP)		260+0/-5 °C
Time within 5°C of actual peak Temperature (tp)		20 – 40 seconds
Ramp-down Rate		6°C/second max
Time 25°C to peak Temperature (TP)		8 minutes Max.
Do not exceed		280°C

Looking for pricing, stock, or lifecycle information?

Click below to explore more details on WIN SOURCE:

- ⊖ [View HS2G on WIN SOURCE](#)
- ⊖ [GOOD-ARK Electronics Information](#)

Optimize Your Supply Chain with WIN SOURCE Solutions

- ✓ Global Sourcing Solution
- ✓ Obsolete Management
- ✓ Cost Control Management
- ✓ Shortage Management
- ✓ Alternative Solution
- ✓ Excess Inventory Management