



**THE DATASHEET OF
ADCLK846BCPZ-REEL7**



FEATURES

- Selectable LVDS/CMOS outputs
- Up to 6 LVDS (1.2 GHz) or 12 CMOS (250 MHz) outputs
- <16 mW per channel (100 MHz operation)
- 54 fs integrated jitter (12 kHz to 20 MHz)
- 100 fs additive broadband jitter
- 2.0 ns propagation delay (LVDS)
- 135 ps output rise/fall (LVDS)
- 65 ps output-to-output skew (LVDS)
- Sleep mode
- Pin-programmable control
- 1.8 V power supply

APPLICATIONS

- Low jitter clock distribution
- Clock and data signal restoration
- Level translation
- Wireless communications
- Wired communications
- Medical and industrial imaging
- ATE and high performance instrumentation

GENERAL DESCRIPTION

The **ADCLK846** is a 1.2 GHz/250 MHz, LVDS/CMOS, fanout buffer optimized for low jitter and low power operation. Possible configurations range from 6 LVDS to 12 CMOS outputs, including combinations of LVDS and CMOS outputs. Two control lines are used to determine whether fixed blocks of outputs are LVDS or CMOS outputs.

FUNCTIONAL BLOCK DIAGRAM

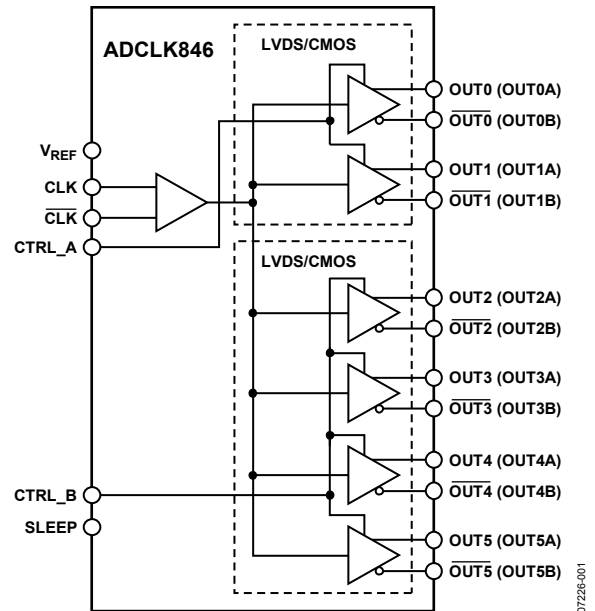

Figure 1.

The clock input accepts various types of single-ended and differential logic levels including LVPECL, LVDS, HSTL, CML, and CMOS.

Table 8 provides interface options for each type of connection. The SLEEP pin enables a sleep mode to power down the device.

This device is available in a 24-pin LFCSP package. It is specified for operation over the standard industrial temperature range of -40°C to $+85^{\circ}\text{C}$.

TABLE OF CONTENTS

Features	1	Typical Performance Characteristics	8
Applications	1	Functional Description	11
Functional Block Diagram	1	Clock Inputs	11
General Description	1	AC-Coupled Applications	11
Revision History	2	Clock Outputs	12
Specifications	3	Control and Function Pins	12
Electrical Characteristics	3	Power Supply	12
Timing Characteristics	4	Applications Information	13
Clock Characteristics	5	Using the ADCLK846 Outputs for ADC Clock	
Logic and Power Characteristics	5	Applications	13
Absolute Maximum Ratings	6	LVDS Clock Distribution	13
Determining Junction Temperature	6	CMOS Clock Distribution	13
ESD Caution	6	Input Termination Options	14
Thermal Performance	6	Outline Dimensions	15
Pin Configuration and Function Descriptions	7	Ordering Guide	15

REVISION HISTORY

9/2017—Rev. B to Rev. C

Changes to Figure 2	7
Updated Outline Dimensions	15
Changes to Ordering Guide	15

5/2010—Rev. A to Rev. B

Changes to Integrated Random Jitter Conditions	4
--	---

6/2009—Rev. 0 to Rev. A

No Content Updates	Throughout
--------------------------	------------

4/2009—Revision 0: Initial Version

SPECIFICATIONS

ELECTRICAL CHARACTERISTICS

Typical values are given for $V_S = 1.8\text{ V}$ and $T_A = 25^\circ\text{C}$, unless otherwise noted. Minimum and maximum values are given over the full $V_S = 1.8\text{ V} \pm 5\%$ and $T_A = -40^\circ\text{C}$ to $+85^\circ\text{C}$ variations, unless otherwise noted. Input slew rate $> 1\text{ V/ns}$, unless otherwise noted.

Table 1.

Parameter	Symbol	Min	Typ	Max	Unit	Conditions
CLOCK INPUTS						
Input Frequency		0		1200	MHz	Differential input
Input Sensitivity, Differential			150		mV p-p	Jitter performance is improved with higher slew rates (greater voltage swing)
Input Level				1.8	V p-p	Larger voltage swings can turn on the protection diodes and can degrade jitter performance
Input Common-Mode Voltage	V_{CM}	$V_S/2 - 0.1$		$V_S/2 + 0.05$	V	Inputs are self-biased; enables ac coupling
Input Common-Mode Range	V_{CMR}	0.4		$V_S - 0.4$	V	Inputs are dc-coupled with 200 mV p-p signal applied
Input Voltage Offset			30		mV	
Input Sensitivity, Single-Ended			150		mV p-p	CLK ac-coupled; $\overline{\text{CLK}}$ ac-bypassed to ground
Input Resistance (Differential)			7		k Ω	
Input Capacitance	C_{IN}		2		pF	
Input Bias Current (Each Pin)		-350		+350	μA	Full input swing
LVDS CLOCK OUTPUTS						
Output Frequency				1200	MHz	Termination = 100 Ω ; differential (OUT_x , $\overline{\text{OUT}}_x$)
Differential Output Voltage	V_{OD}	247	344	454	mV	See Figure 9 for a swing vs. frequency plot
	ΔV_{OD}			50	mV	
Offset Voltage	V_{OS}	1.125	1.25	1.375	V	
	ΔV_{OS}			50	mV	
Short-Circuit Current	I_{SA}, I_{SB}		3	6	mA	Each pin (output shorted to GND)
CMOS CLOCK OUTPUTS						
Output Frequency				250	MHz	Single-ended; termination = open OUT_x and $\overline{\text{OUT}}_x$ in phase With 10 pF load each output; see Figure 16 for swing vs. frequency
Output Voltage High	V_{OH}	$V_S - 0.1$			V	At 1 mA load
		$V_S - 0.35$			V	At 10 mA load
Output Voltage Low	V_{OL}			0.1	V	At 1 mA load
				0.35	V	At 10 mA load
Reference Voltage	V_{REF}				V	
Output Voltage		$V_S/2 - 0.1$	$V_S/2$	$V_S/2 + 0.1$	V	$\pm 500\ \mu\text{A}$
Output Resistance			60		Ω	
Output Current				500	μA	

TIMING CHARACTERISTICS

Table 2.

Parameter	Symbol	Min	Typ	Max	Unit	Conditions
LVDS OUTPUTS						
Output Rise/Fall Time	t_R, t_F		135	235	ps	Termination = 100 Ω differential; 3.5 mA 20% to 80% measured differentially
Propagation Delay, CLK-to-LVDS Output	t_{PD}	1.5	2.0	2.7	ns	$V_{ICM} = V_{REF}, V_{ID} = 0.5 V$
Temperature Coefficient			2.0		ps/ $^{\circ}C$	
Output Skew ¹						
All LVDS Outputs on the Same Part				65	ps	
All LVDS Outputs Across Multiple Parts				390	ps	
Additive Time Jitter						
Integrated Random Jitter			54		fs rms	BW = 12 kHz to 20 MHz, CLK = 1000 MHz
			74		fs rms	BW = 50 kHz to 80 MHz, CLK = 1000 MHz
			86		fs rms	BW = 10 Hz to 100 MHz, CLK = 1000 MHz
Broadband Random Jitter ²			150		fs rms	Input slew rate = 1 V/ns
Crosstalk-Induced Jitter			260		fs rms	Calculated from spur energy with an interferer 10 MHz offset from carrier
CMOS OUTPUTS						
Output Rise/Fall Time	t_R, t_F		525	950	ps	Termination = open 20% to 80%; CMOS load = 10 pF
Propagation Delay, CLK-to-CMOS Output	t_{PD}	2.5	3.2	4.2	ns	10 pF load
Temperature Coefficient			2.2		ps/ $^{\circ}C$	
Output Skew ²						
All CMOS Outputs on the Same Part				175	ps	
All CMOS Outputs Across Multiple Parts				640	ps	
Additive Time Jitter						
Integrated Random Jitter			56		fs rms	BW = 12 kHz to 20 MHz, CLK = 200 MHz
Broadband Random Jitter ³			100		fs rms	Input slew = 2 V/ns; see Figure 11
Crosstalk-Induced Jitter			260		fs rms	Calculated from spur energy with an interferer 10 MHz offset from carrier
LVDS-TO-CMOS OUTPUT SKEW²						
LVDS Output(s) and CMOS Output(s) on the Same Part		0.8		1.6	ns	CMOS load = 10 pF and LVDS load = 100 Ω

¹ This is the difference between any two similar delay paths while operating at the same voltage and temperature.² Measured at rising edge of clock signal.³ Calculated from SNR of ADC method.

CLOCK CHARACTERISTICS**Table 3. Clock Output Phase Noise**

Parameter	Min	Typ	Max	Unit	Conditions
CLK-TO-LVDS ABSOLUTE PHASE NOISE 1000 MHz		-90		dBc/Hz	Input slew rate > 1 V/ns At 10 Hz offset
		-108		dBc/Hz	At 100 Hz offset
		-117		dBc/Hz	At 1 kHz offset
		-126		dBc/Hz	At 10 kHz offset
		-134		dBc/Hz	At 100 kHz offset
		-141		dBc/Hz	At 1 MHz offset
		-146		dBc/Hz	At 10 MHz offset
CLK-TO-CMOS ABSOLUTE PHASE NOISE 200 MHz		-100		dBc/Hz	Input slew rate > 1 V/ns At 10 Hz offset
		-117		dBc/Hz	At 100 Hz offset
		-128		dBc/Hz	At 1 kHz offset
		-138		dBc/Hz	At 10 kHz offset
		-147		dBc/Hz	At 100 kHz offset
		-153		dBc/Hz	At 1 MHz offset
		-156		dBc/Hz	At 10 MHz offset

LOGIC AND POWER CHARACTERISTICS**Table 4. Control Pin Characteristics**

Parameter	Symbol	Min	Typ	Max	Unit	Conditions
CONTROL PINS (CTRL_A, CTRL_B, SLEEP) ¹						
Logic 1 Voltage	V _{IH}	V _S - 0.4			V	
Logic 0 Voltage	V _{IL}			0.4	V	
Logic 1 Current	I _{IH}	5	8	20	μA	
Logic 0 Current	I _{IL}	-5		+5	μA	
Capacitance			2		pF	
POWER						
Supply Voltage Requirement	V _S	1.71	1.8	1.89	V	V _S = 1.8 V ± 5%
LVDS Outputs, Full Operation						
LVDS at 100 MHz			55	70	mA	All outputs enabled as LVDS and loaded, R _L = 100 Ω
LVDS at 1200 MHz			110	130	mA	All outputs enabled as LVDS and loaded, R _L = 100 Ω
CMOS Outputs, Full Operation						
CMOS at 100 MHz			75	95	mA	All outputs enabled as CMOS and loaded, CMOS load = 10 pF
CMOS at 250 MHz			155	190	mA	All outputs enabled as CMOS and loaded, CMOS load = 10 pF
Sleep				3	mA	SLEEP pin pulled high; does not include power dissipated in external resistors
Power Supply Rejection ²						
LVDS	PSR _{TPD}		0.9		ps/mV	
CMOS	PSR _{TPD}		1.2		ps/mV	

¹ These pins each have a 200 kΩ internal pull-down resistor.² Change in T_{PD} per change in V_S.

ABSOLUTE MAXIMUM RATINGS

Table 5.

Parameter	Rating
Supply Voltage V_S to GND	2 V
Inputs CLK and $\overline{\text{CLK}}$	-0.3 V to +2 V
CMOS Inputs	-0.3 V to +2 V
Outputs Maximum Voltage	-0.3 V to +2 V
Voltage Reference Voltage (V_{REF})	-0.3 V to +2 V
Operating Temperature Range Ambient	-40°C to +85°C
Junction	150°C
Storage Temperature Range	-65°C to +150°C

Stresses at or above those listed under Absolute Maximum Ratings may cause permanent damage to the product. This is a stress rating only; functional operation of the product at these or any other conditions above those indicated in the operational section of this specification is not implied. Operation beyond the maximum operating conditions for extended periods may affect product reliability.

DETERMINING JUNCTION TEMPERATURE

To determine the junction temperature on the application PCB, use the following formula:

$$T_J = T_{\text{CASE}} + (\Psi_{\text{JT}} \times PD)$$

where:

T_J is the junction temperature (°C).

T_{CASE} is the case temperature (°C) measured by the customer at top center of the package.

Ψ_{JT} is indicated in Table 6.

PD is the power dissipation.

Values of θ_{JA} are provided for package comparison and PCB design considerations. θ_{JA} can be used for a first-order approximation of T_J by the equation

$$T_J = T_A + (\theta_{\text{JA}} \times PD)$$

where T_A is the ambient temperature (°C).

Values of θ_{JB} are provided for package comparison and PCB design considerations.

ESD CAUTION



ESD (electrostatic discharge) sensitive device.

Charged devices and circuit boards can discharge without detection. Although this product features patented or proprietary protection circuitry, damage may occur on devices subjected to high energy ESD. Therefore, proper ESD precautions should be taken to avoid performance degradation or loss of functionality.

THERMAL PERFORMANCE

Table 6.

Parameter	Symbol	Description	Value ¹	Unit
Junction-to-Ambient Thermal Resistance Still Air 0.0 m/sec Airflow	θ_{JA}	Per JEDEC JESD51-2	57.0	°C/W
Moving Air 1.0 m/sec Airflow	θ_{JMA}	Per JEDEC JESD51-6	49.8	°C/W
2.5 m/sec Airflow			44.7	°C/W
Junction-to-Board Thermal Resistance Moving Air 1.0 m/sec Airflow	θ_{JB}	Per JEDEC JESD51-8	35.2	°C/W
Junction-to-Case Thermal Resistance Moving Air Die-to-Heat Sink	θ_{JC}	Per MIL-STD 883, Method 1012.1	2.0	°C/W
Junction-to-Top-of-Package Characterization Parameter Still Air 0 m/sec Airflow	Ψ_{JT}	Per JEDEC JESD51-2	1.0	°C/W

¹ Results are from simulations. The PCB is a JEDEC multilayer type. Thermal performance for actual applications requires careful inspection of the conditions in the application to determine if they are similar to those assumed in these calculations.

PIN CONFIGURATION AND FUNCTION DESCRIPTIONS

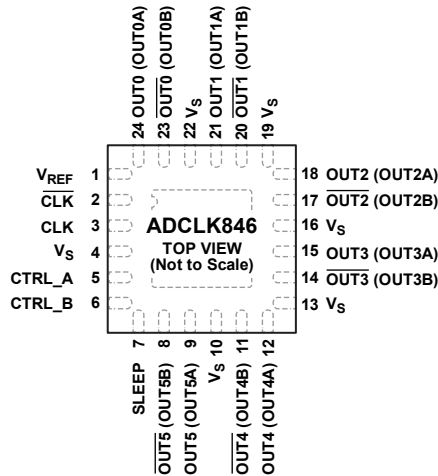

NOTES:
1. EXPOSED PADDLE MUST BE CONNECTED TO GND.

0726-002

Figure 2. Pin Configuration

Table 7. Pin Function Descriptions

Pin No.	Mnemonic	Description
1	V _{REF}	Reference Voltage.
2	$\overline{\text{CLK}}$	Clock Input (Negative).
3	CLK	Clock Input (Positive).
4, 10, 13, 16, 19, 22	V _S	Supply Voltage.
5	CTRL_A	CMOS Input Control for Output 1 to Output 0. (0: LVDS, 1: CMOS.)
6	CTRL_B	CMOS Input Control for Output 5 to Output 2. (0: LVDS, 1: CMOS.)
7	SLEEP	CMOS Input for Sleep Mode. (0: normal operation, 1: sleep.)
8	$\overline{\text{OUT5}}$ (OUT5B)	Complementary Side of Differential LVDS Output 5, or CMOS Output 5 on Channel B.
9	OUT5 (OUT5A)	True Side of Differential LVDS Output 5, or CMOS Output 5 on Channel A.
11	$\overline{\text{OUT4}}$ (OUT4B)	Complementary Side of Differential LVDS Output 4, or CMOS Output 4 on Channel B.
12	OUT4 (OUT4A)	True Side of Differential LVDS Output 4, or CMOS Output 4 on Channel A.
14	$\overline{\text{OUT3}}$ (OUT3B)	Complementary Side of Differential LVDS Output 3, or CMOS Output 3 on Channel B.
15	OUT3 (OUT3A)	True Side of Differential LVDS Output 3, or CMOS Output 3 on Channel A.
17	$\overline{\text{OUT2}}$ (OUT2B)	Complementary Side of Differential LVDS Output 2, or CMOS Output 2 on Channel B.
18	OUT2 (OUT2A)	True Side of Differential LVDS Output 2, or CMOS Output 2 on Channel A.
20	$\overline{\text{OUT1}}$ (OUT1B)	Complementary Side of Differential LVDS Output 1, or CMOS Output 1 on Channel B.
21	OUT1 (OUT1A)	True Side of Differential LVDS Output 1, or CMOS Output 1 on Channel A.
23	$\overline{\text{OUT0}}$ (OUT0B)	Complementary Side of Differential LVDS Output 0, or CMOS Output 0 on Channel B.
24	OUT0 (OUT0A)	True Side of Differential LVDS Output 0, or CMOS Output 0 on Channel A.
(25)	EPAD	Exposed Paddle. The exposed paddle must be connected to ground.

TYPICAL PERFORMANCE CHARACTERISTICS

$V_S = 1.8\text{ V}$, $T_A = 25^\circ\text{C}$, unless otherwise noted.

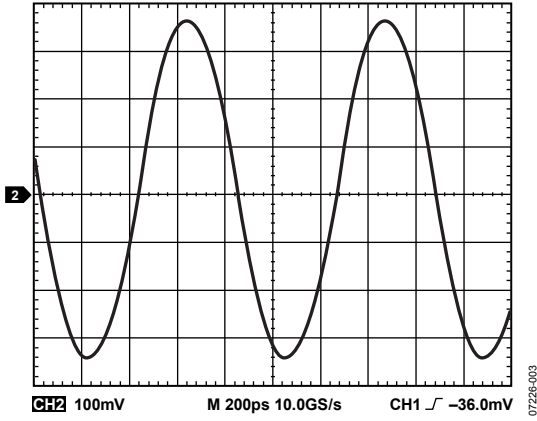

Figure 3. LVDS Output Waveform at 1200 MHz

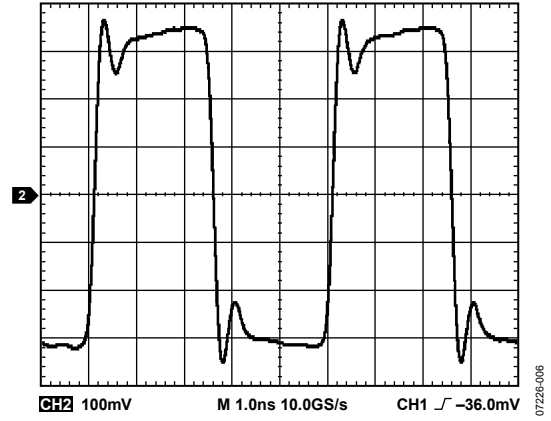

Figure 6. LVDS Output Waveform at 200 MHz

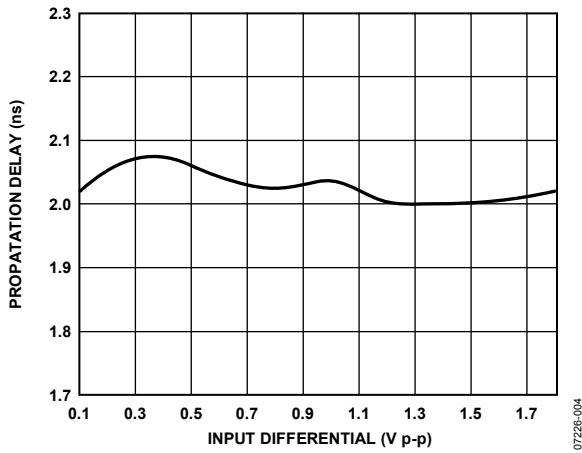

Figure 4. LVDS Propagation Delay vs. V_{ID}

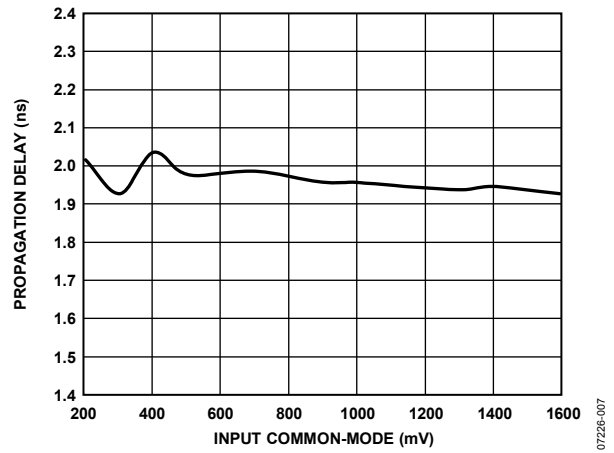

Figure 7. LVDS Propagation Delay vs. V_{CM}

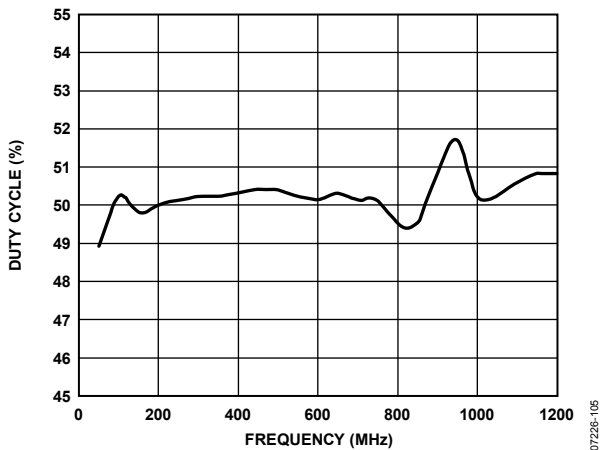

Figure 5. LVDS Output Duty Cycle vs. Frequency

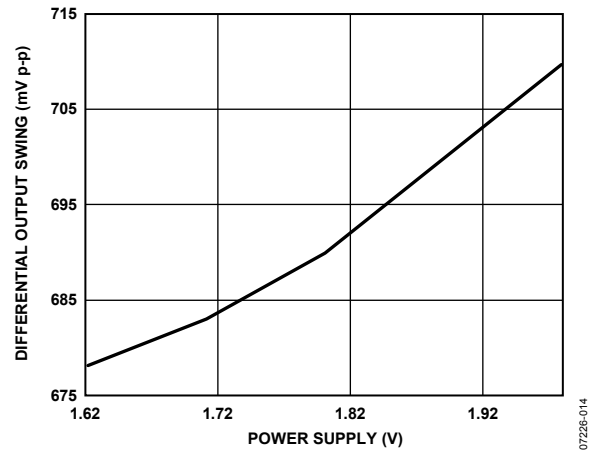

Figure 8. LVDS Output Swing vs. Power Supply Voltage

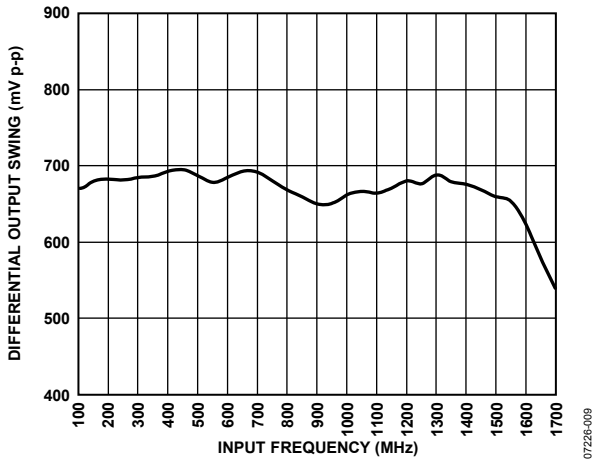

Figure 9. LVDS Differential Output Swing vs. Input Frequency

07226-009

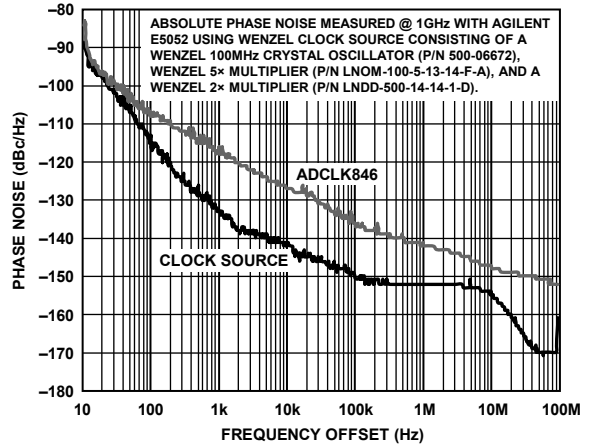

Figure 12. Absolute Phase Noise LVDS at 1000 MHz

07226-112

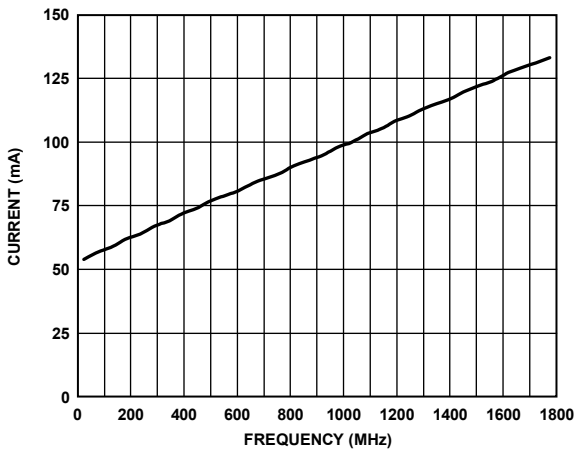

Figure 10. LVDS Current vs. Frequency, All Banks Set to LVDS

07226-110

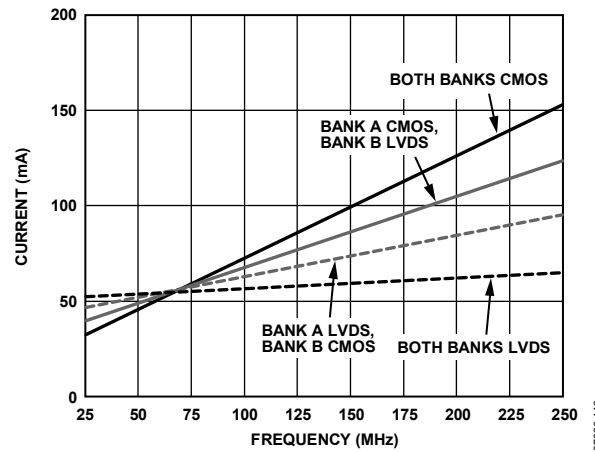

Figure 13. LVDS/CMOS Current vs. Frequency with Various Logic Combinations

07226-113

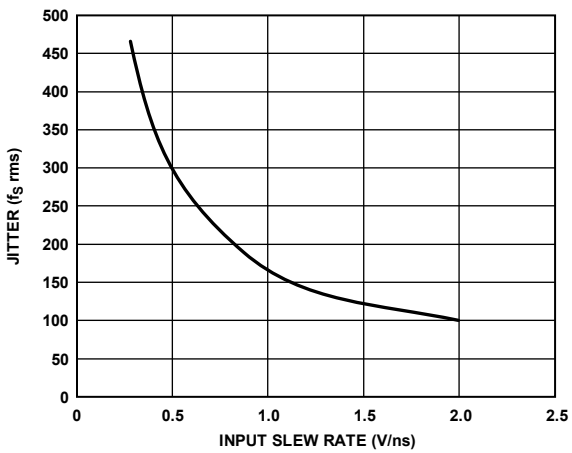

Figure 11. Additive Broadband Jitter vs. Input Slew Rate

07226-011

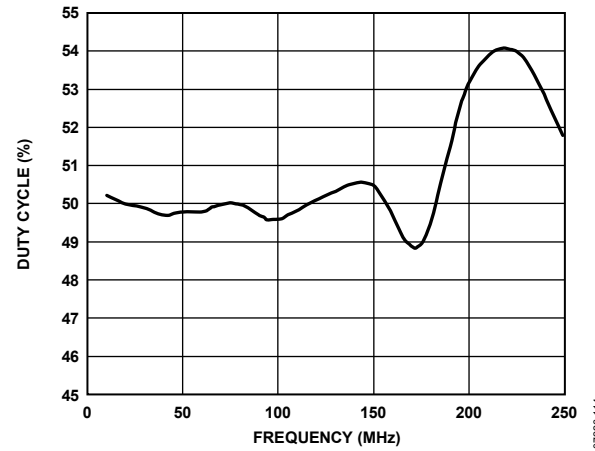

Figure 14. CMOS Output Duty Cycle vs. Frequency, 10 pF Load

07226-114

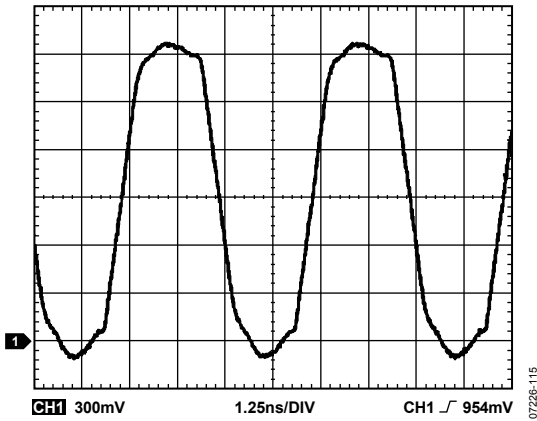

Figure 15. CMOS Output Waveform at 200 MHz, 10 pF Load

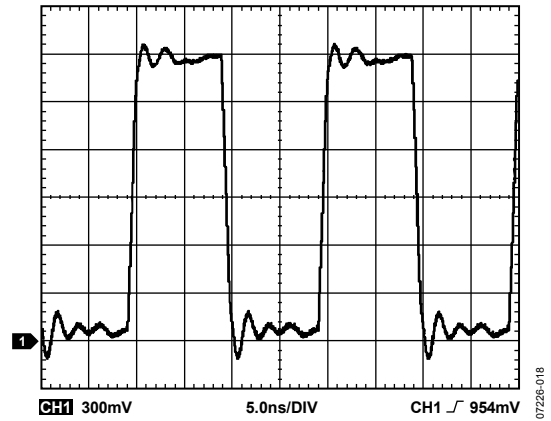

Figure 18. CMOS Output Waveform at 50 MHz, 10 pF Load

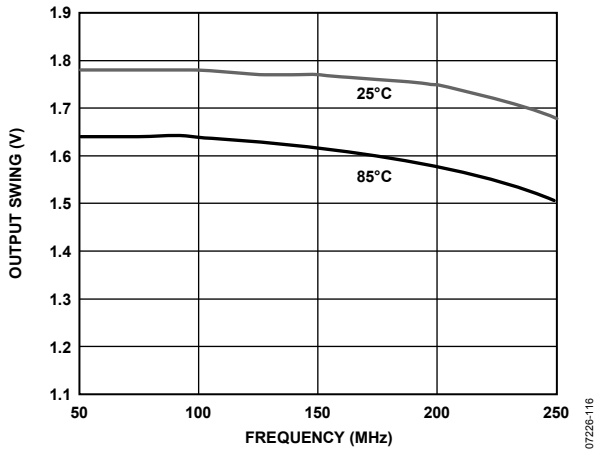

Figure 16. CMOS Output Swing vs. Frequency and Temperature, 10 pF Load

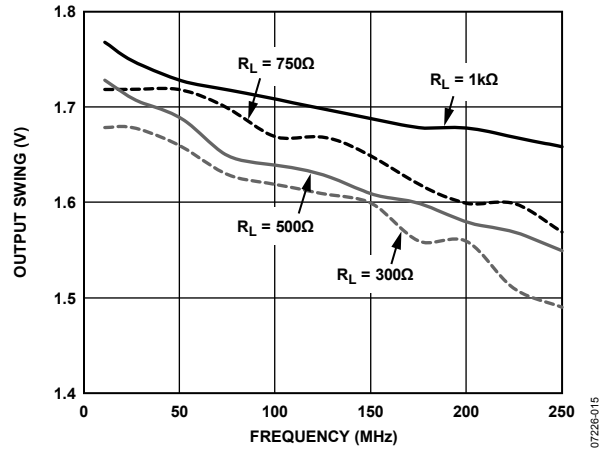

Figure 19. CMOS Output Swing vs. Frequency and Resistive Load

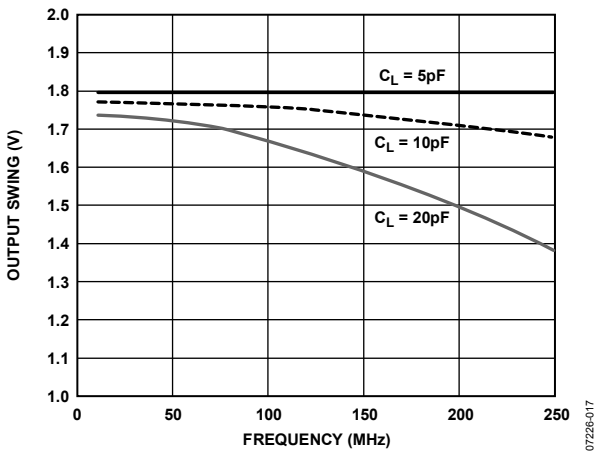

Figure 17. CMOS Output Swing vs. Frequency and Capacitive Load

FUNCTIONAL DESCRIPTION

The ADCLK846 clock input is distributed to all output channels. Each channel bank is pin programmable for either LVDS or CMOS levels. This allows the selection of multiple logic configurations ranging from 6 LVDS to 12 CMOS outputs, along with other combinations using both types of logic.

CLOCK INPUTS

The differential inputs of the ADCLK846 are internally self-biased. The clock inputs have a resistor divider, which sets the common-mode level for the inputs. The complementary inputs are biased about 30 mV lower than the true input to avoid oscillations if the input signal ceases. See Figure 20 for the equivalent input circuit.

The inputs can be ac-coupled or dc-coupled. Table 8 displays a guide for input logic compatibility. If a single-ended input is desired, this can be accommodated by ac or dc coupling to one side of the differential input. Bypass the other input to ground by a capacitor.

Note that jitter performance degrades with low input slew rate, as shown in Figure 11. See Figure 28 through Figure 32 for different termination schemes.

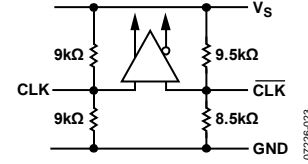

Figure 20. ADCLK846 Input Stage

AC-COUPLED APPLICATIONS

When ac coupling is desired, the ADCLK846 offers two options. The first option requires no external components (excluding the dc blocking capacitor); it allows the user to couple the reference signal onto the clock input pins (see Figure 31).

The second option allows the use of the V_{REF} pin to set the dc bias level for the ADCLK846. The V_{REF} pin can be connected to CLK and \overline{CLK} through resistors. This method allows lower impedance termination of signals at the ADCLK846 (see Figure 32).

The internal bias resistors are still in parallel with the external biasing. However, the relatively high impedance of the internal resistors allows the external termination to V_{REF} to dominate. This is also useful if it is not desirable to offset the inputs slightly as previously mentioned using only the internal biasing.

Table 8. Input Logic Compatibility

Supply (V)	Logic	Common Mode (V)	Output Swing (V)	AC-Coupled	DC-Coupled
3.3	CML	2.9	0.8	Yes	Not allowed
2.5	CML	2.1	0.8	Yes	Not allowed
1.8	CML	1.4	0.8	Yes	Yes
3.3	CMOS	1.65	3.3	Not allowed	Not allowed
2.5	CMOS	1.25	2.5	Not allowed	Not allowed
1.8	CMOS	0.9	1.8	Yes	Yes
1.5	HSTL	0.75	0.75	Yes	Yes
	LVDS	1.25	0.4	Yes	Yes
3.3	LVPECL	2.0	0.8	Yes	Not allowed
2.5	LVPECL	1.2	0.8	Yes	Yes
1.8	LVPECL	0.5	0.8	Yes	Yes

CLOCK OUTPUTS

Each driver consists of a differential LVDS output or two single-ended CMOS outputs (always in phase). When the LVDS driver is enabled, the corresponding CMOS driver is in tristate. When the CMOS driver is enabled, the corresponding LVDS driver is powered down and tristated. Figure 21 and Figure 22 display the equivalent output stage.

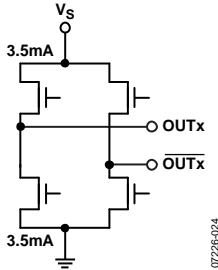

Figure 21. LVDS Output Simplified Equivalent Circuit

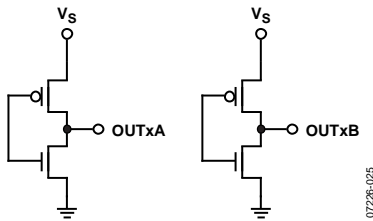

Figure 22. CMOS Equivalent Output Circuit

CONTROL AND FUNCTION PINS

Logic Select for CTRL_A

CTRL_A selects either CMOS (high) or LVDS (low) logic for Output 1 and Output 0. This pin has an internal 200 kΩ pull-down resistor.

Logic Select for CTRL_B

CTRL_B selects either CMOS (high) or LVDS (low) logic for Output 5, Output 4, Output 3, and Output 2. This pin has an internal 200 kΩ pull-down resistor.

Sleep Mode

SLEEP powers down the chip except for the band gap. The input is active high, which puts the outputs into a high-Z state. This pin has a 200 kΩ pull-down resistor. The control pins are operational during sleep mode.

POWER SUPPLY

The ADCLK846 requires a 1.8 V ± 5% power supply for V_s. Best practice recommends bypassing the power supply on the PCB with adequate capacitance (>10 μF) and bypassing all power pins with adequate capacitance (0.1 μF) as close to the part as possible. The layout of the ADCLK846 evaluation board (ADCLK846/PCBZ) provides a good layout example.

Exposed Metal Paddle

The exposed metal paddle on the ADCLK846 package is an electrical connection, as well as a thermal enhancement. For the device to function properly, the paddle must be properly attached to ground (GND). The ADCLK846 dissipates heat through its exposed paddle. The PCB acts as a heat sink for the ADCLK846. The PCB attachment must provide a good thermal path to a larger heat dissipation area, such as the ground plane on the PCB. This requires a grid of vias from the top layer down to the ground plane. See Figure 23 for an example.

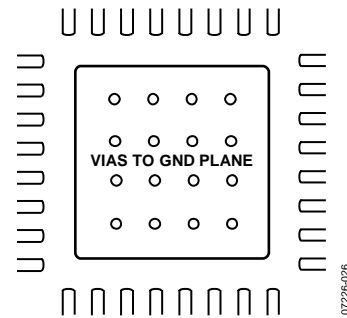

Figure 23. PCB Land Example for Attaching Exposed Paddle

APPLICATIONS INFORMATION

USING THE ADCLK846 OUTPUTS FOR ADC CLOCK APPLICATIONS

Any high speed analog-to-digital converter (ADC) is extremely sensitive to the quality of the sampling clock provided by the user. An ADC can be thought of as a sampling mixer, and any noise, distortion, or timing jitter on the clock is combined with the desired signal at the ADC output. Clock integrity requirements scale with the analog input frequency and resolution, with higher analog input frequency applications at ≥ 14 -bit resolution being the most stringent. The theoretical SNR of an ADC is limited by the ADC resolution and the jitter on the sampling clock. Considering an ideal ADC of infinite resolution where the step size and quantization error can be ignored, the available SNR can be expressed approximately by

$$SNR = 20 \log \left[\frac{1}{2\pi f_A T_J} \right]$$

where:

f_A is the highest analog frequency being digitized.

T_J is the rms jitter on the sampling clock.

Figure 24 shows the required sampling clock jitter as a function of the analog frequency and effective number of bits (ENOB). See AN-756 Application Note and AN-501 Application Note for more information.

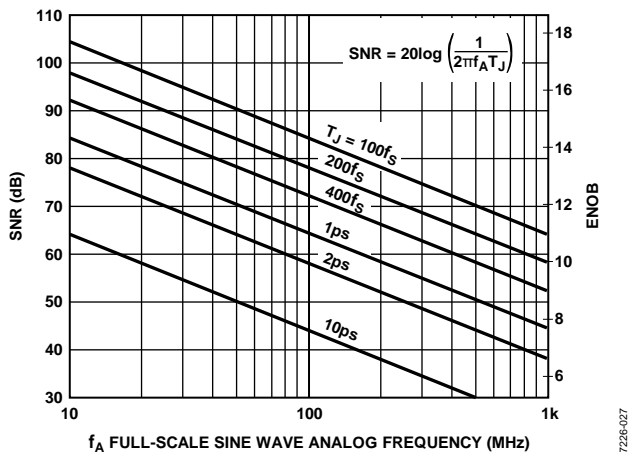

Figure 24. SNR and ENOB vs. Analog Input Frequency

Many high performance ADCs feature differential clock inputs to simplify the task of providing the required low jitter clock on a noisy PCB. Distributing a single-ended clock on a noisy PCB can result in coupled noise on the sample clock. Differential distribution has inherent common-mode rejection that can provide superior clock performance in a noisy environment. The ADCLK846 features LVDS outputs that provide differential clock outputs, which enable clock solutions that maximize converter SNR performance. Consider the input requirements of the ADC (differential or single-ended, logic level, termination) when selecting the best clocking/converter solution.

LVDS CLOCK DISTRIBUTION

The ADCLK846 provides clock outputs that are selectable as either CMOS or LVDS level outputs. LVDS is a differential output option that uses a current-mode output stage. The nominal current is 3.5 mA, which yields 350 mV output swing across a 100 Ω resistor. The LVDS output meets or exceeds all ANSI/TIA/EIA-644 specifications. A recommended termination circuit for the LVDS outputs is shown in Figure 25.

If ac coupling is necessary, place decoupling capacitors either before or after the 100 Ω termination resistor.

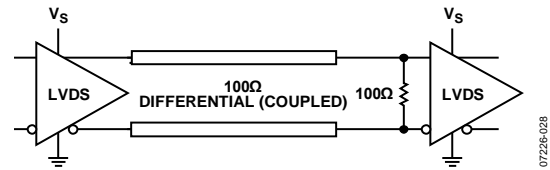

Figure 25. LVDS Output Termination

See the AN-586 Application Note at www.analog.com for more information on LVDS.

CMOS CLOCK DISTRIBUTION

The output drivers of the ADCLK846 can also be configured as CMOS drivers. When selected as a CMOS driver, each output becomes a pair of CMOS outputs. These outputs are 1.8 V CMOS compatible.

When single-ended CMOS clocking is used, some of the following guidelines outlined in this section apply.

Design point-to-point connections such that each driver has only one receiver, if possible. Connecting outputs in this manner allows for simple termination schemes and minimizes ringing due to possible mismatched impedances on the output trace. Series termination at the source is generally required to provide transmission line matching and/or to reduce current transients at the driver.

The value of the resistor is dependent on the board design and timing requirements (typically 10 Ω to 100 Ω is used). CMOS outputs are also limited in terms of the capacitive load or trace length that they can drive. Typically, trace lengths less than 3 inches are recommended to preserve signal rise/fall times and signal integrity.

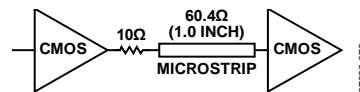

Figure 26. Series Termination of CMOS Output

Termination at the far end of the PCB trace is a second option. The CMOS outputs of the ADCLK846 do not supply enough current to provide a full voltage swing with a low impedance resistive, far-end termination, as shown in Figure 27. Match the far-end termination network to the PCB trace impedance and provide the desired switching point. The reduced signal swing may still meet receiver input requirements in some applications. This can be useful when driving long trace lengths on less critical nets.

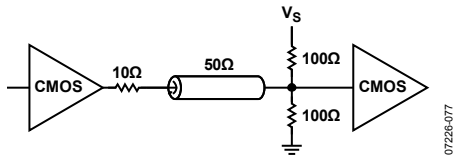

Figure 27. CMOS Output with Far-End Termination

Because of the limitations of single-ended CMOS clocking, consider using differential outputs when driving high speed signals over long traces. The ADCLK846 offers LVDS outputs that are better suited for driving long traces where the inherent noise immunity of differential signaling provides superior performance for clocking converters.

INPUT TERMINATION OPTIONS

For single-ended operation, always bypass unused input to GND as shown in Figure 31.

Figure 32 illustrates the use of the V_{REF} to provide low impedance termination into $V_s/2$. In addition, Figure 32 shows a way to negate the 30 mV input offset with external resistor values. For example, use 1.8 V CMOS with long traces to provide far-end termination.

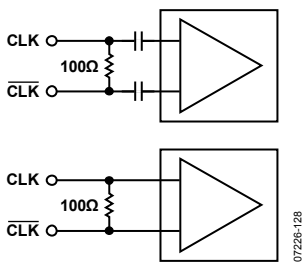

Figure 28. Typical AC-Coupled or DC-Coupled LVDS or HSTL Configurations (see Table 8)

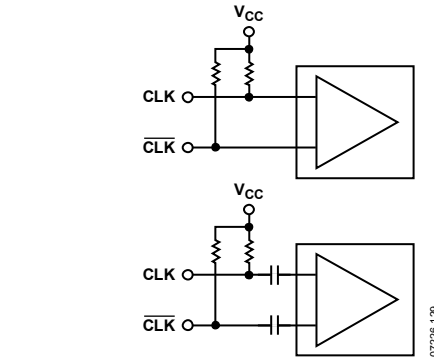

Figure 29. Typical AC-Coupled or DC-Coupled CML Configurations (see Table 8 for CML Coupling Limitations)

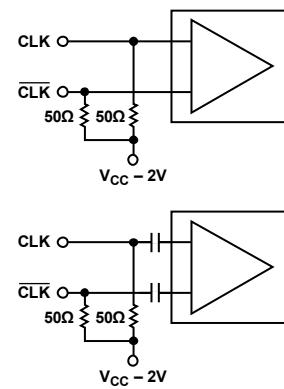

Figure 30. Typical AC-Coupled or DC-Coupled LVPECL Configurations (see Table 8 for LVPECL DC Coupling Limitations)

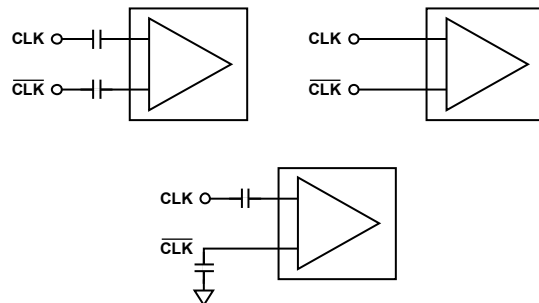

Figure 31. Typical 1.8 V CMOS Configurations for Short Trace Lengths (see Table 8 for CMOS compatibility)

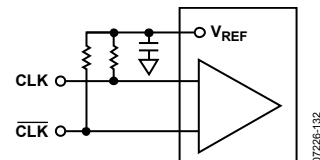
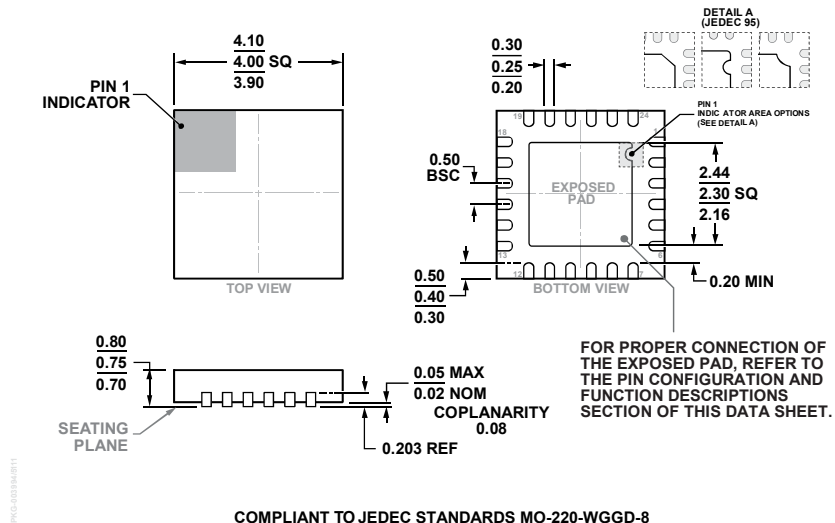

Figure 32. Use of the V_{REF} to Provide Low Impedance Termination into $V_s/2$

OUTLINE DIMENSIONS



COMPLIANT TO JEDEC STANDARDS MO-220-WGGD-8
 Figure 33. 24-Lead Lead Frame Chip Scale Package [LFCSP]
 4 mm × 4 mm Body and 0.75 mm Package Height
 CP-24-14
 Dimensions shown in millimeters

ORDERING GUIDE

Model ¹	Temperature Range	Package Description	Package Option
ADCLK846BCPZ	-40°C to +85°C	24-Lead LFCSP	CP-24-14
ADCLK846BCPZ-REEL7	-40°C to +85°C	24-Lead LFCSP	CP-24-14
ADCLK846/PCBZ		Evaluation Board	

¹ Z = RoHS Compliant Part.

Looking for pricing, stock, or lifecycle information?

Click below to explore more details on WIN SOURCE:

- ⊖ View [ADCLK846BCPZ-REEL7](#) on WIN SOURCE
- ⊖ [Analog Devices Inc.](#) Information

Optimize Your Supply Chain with WIN SOURCE Solutions

- ✓ Global Sourcing Solution
- ✓ Obsolete Management
- ✓ Cost Control Management
- ✓ Shortage Management
- ✓ Alternative Solution
- ✓ Excess Inventory Management