



**THE DATASHEET OF  
EL7513IWTZ-T7**



## EL7513

White LED Step-Up Regulator

**NOT RECOMMENDED FOR NEW DESIGNS  
RECOMMENDED REPLACEMENT PART  
ISL97634**

FN7112  
Rev 5.00  
December 22, 2008

The EL7513 is a constant current boost regulator specially designed for driving white LEDs. It can drive 4 LEDs in series or up to 12 LEDs in parallel/series configuration and achieves efficiency up to 91%.

The brightness of the LEDs is adjusted through a voltage level on the CNTL pin. When the level falls below 0.1V, the chip goes into shut-down mode and consumes less than 1µA of supply current for  $V_{IN}$  less than 5.5V.

The EL7513 is available in the 8 Ld TSOT and 8 Ld MSOP packages. The TSOT package is just 1mm high, compared to 1.45mm for the standard SOT23 package.

### Features

- 2.6V to 13.2V input voltage
- 18V maximum output voltage
- Drives up to 12 LEDs
- 1MHz switching frequency
- Up to 91% efficiency
- 1µA maximum shut-down current
- Dimming control
- 8 Ld TSOT and 8 Ld MSOP packages
- Pb-free available (RoHS compliant)

### Applications

- PDAs
- Cellular phones
- Digital cameras
- White LED backlighting

### Ordering Information

PART NUMBER	PART MARKING	TEMP. RANGE (°C)	PACKAGE	PKG. DWG. #
EL7513IWT-T7*	9	-40 to +85	8 Ld TSOT Tape and Reel	MDP0049
EL7513IWT-T7A*	9	-40 to +85	8 Ld TSOT Tape and Reel	MDP0049
EL7513IWTZ-T7* (See Note)	BAAA	-40 to +85	8 Ld TSOT Tape and Reel (Pb-Free)	MDP0049
EL7513IWTZ-T7A* (See Note)	BAAA	-40 to +85	8 Ld TSOT Tape and Reel (Pb-Free)	MDP0049
EL7513IY	d	-40 to +85	8 Ld MSOP	MDP0043
EL7513IY-T7*	d	-40 to +85	8 Ld MSOP Tape and Reel	MDP0043
EL7513IY-T13*	d	-40 to +85	8 Ld MSOP Tape and Reel	MDP0043
EL7513IYZ (See Note)	BAABA	-40 to +85	8 Ld MSOP (Pb-Free)	MDP0043
EL7513IYZ-T7* (See Note)	BAABA	-40 to +85	8 Ld MSOP Tape and Reel (Pb-Free)	MDP0043
EL7513IYZ-T13* (See Note)	BAABA	-40 to +85	8 Ld MSOP Tape and Reel (Pb-Free)	MDP0043

\*Please refer to TB347 for details on reel specifications.

NOTE: These Intersil Pb-free plastic packaged products employ special Pb-free material sets, molding compounds/die attach materials, and 100% matte tin plate plus anneal (e3 termination finish, which is RoHS compliant and compatible with both SnPb and Pb-free soldering operations). Intersil Pb-free products are MSL classified at Pb-free peak reflow temperatures that meet or exceed the Pb-free requirements of IPC/JEDEC J STD-020.

**Pinouts**

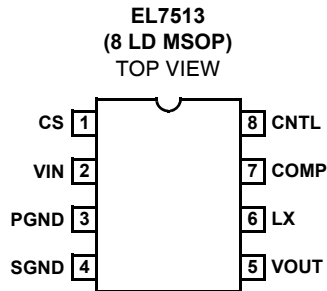
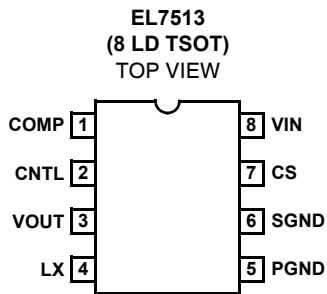

**Typical Connection**

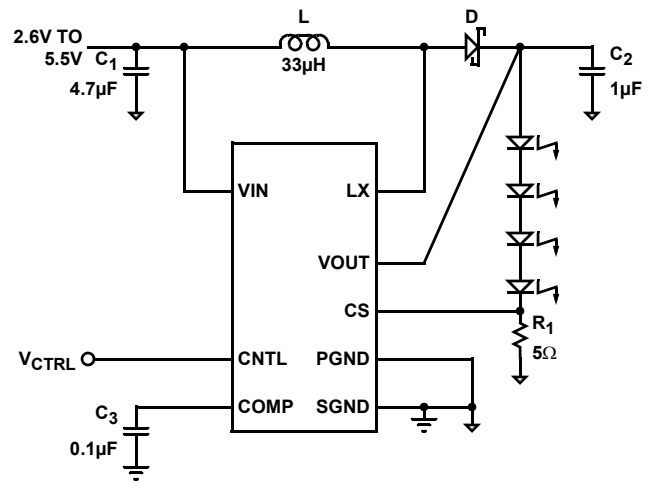

**Absolute Maximum Ratings** (T<sub>A</sub> = +25°C)

COMP, CNTL, CS to SGND . . . . . -0.3V to +6V  
 V<sub>IN</sub> to SGND . . . . . +14V  
 V<sub>OUT</sub> to SGND . . . . . +19V  
 LX to PGND . . . . . +20V

SGND to PGND . . . . . -0.3V to +0.3V  
 Storage Temperature . . . . . -65°C to +150°C  
 Ambient Operating Temperature . . . . . -40°C to +85°C  
 Pb-Free Reflow Profile. . . . . see link below  
<http://www.intersil.com/pbfree/Pb-FreeReflow.asp>

*CAUTION: Do not operate at or near the maximum ratings listed for extended periods of time. Exposure to such conditions may adversely impact product reliability and result in failures not covered by warranty.*

*IMPORTANT NOTE: All parameters having Min/Max specifications are guaranteed. Typ values are for information purposes only. Unless otherwise noted, all tests are at the specified temperature and are pulsed tests, therefore: T<sub>J</sub> = T<sub>C</sub> = T<sub>A</sub>*

**Electrical Specifications** V<sub>IN</sub> = 3V, V<sub>O</sub> = 12V, C<sub>1</sub> = 4.7µF, L = 33µH, C<sub>2</sub> = 1µF, C<sub>3</sub> = 0.1µF, R<sub>1</sub> = 5Ω, T<sub>A</sub> =+ 25°C, Unless Otherwise Specified.

PARAMETER	DESCRIPTION	CONDITIONS	MIN	TYP	MAX	UNIT
V <sub>IN</sub>	Input Voltage		2.6		13.2	V
I <sub>Q1</sub>	Total Input Current at Shut-down	V <sub>CNTL</sub> = 0V			1	µA
I <sub>Q1</sub>	Quiescent Supply Current at V <sub>O</sub> Pin	V <sub>CNTL</sub> = 1V, load disconnected		1	1.5	mA
I <sub>COMP</sub>	COMP Pin Pull-up Current	COMP connected to SGND		11	20	µA
V <sub>COMP</sub>	COMP Voltage Swing		0.5	1.5	2.5	V
I <sub>CNTL</sub>	CNTL Shut-down Current	CNTL = 0V			1	µA
V <sub>CNTL1</sub>	Chip Enable Voltage		240			mV
V <sub>CNTL2</sub>	Chip Disable Voltage				100	mV
I <sub>OUT_ACCURACY</sub>	V <sub>CNTL</sub> = 1V	V <sub>CNTL</sub> = 1V	14	15	16	mA
V <sub>OUT1</sub>	Over-voltage Threshold	V <sub>OUT</sub> rising	17	18	19	V
V <sub>OUT2</sub>	Over-voltage Threshold	V <sub>OUT</sub> falling, with resistive load	15	16	17.5	V
ILX	MOSFET Current Limit		500			mA
R <sub>DSON</sub>	MOSFET On-resistance			0.7		Ω
I <sub>LEAK</sub>	MOSFET Leakage Current	V <sub>CNTL</sub> = 0V, V <sub>LX</sub> = 12V			1	µA
F <sub>S</sub>	Switching Frequency		800	1000	1200	kHz
D <sub>MAX</sub>	Maximum Duty Ratio	V <sub>CNTL</sub> = 2V, I <sub>S</sub> = 0	85	90		%
I <sub>CS</sub>	CS Input Bias Current				1	µA
ΔI <sub>O</sub> /ΔV <sub>IN</sub>	Line Regulation	V <sub>IN</sub> = 2.6V - 5.5V		0.03		%/V

**Pin Descriptions**

8 LD TSOT	8 LD MSOP	PIN NAME	DESCRIPTION
1	7	COMP	Compensation pin. A compensation cap (4700pF to 1µF) is normally connected between this pin and SGND.
2	8	CNTL	Control pin for dimming and shut-down. A voltage between 250mV and 5.5V controls the brightness, and less than 100mV shuts down the converter.
3	5	VOU	Output voltage sense. Use for over voltage protection.
4	6	LX	Inductor connection pin. The drain of internal MOSFET.
5	3	PGND	Power Ground pin. The source of internal MOSFET.
6	4	SGND	Signal Ground. Ground pin for internal control circuitry. Needs to connect to PGND at only one point.
7	1	CS	Current sense pin. Connect to sensing resistor to set the LED bias current.
8	2	VIN	Power supply for internal control circuitry.



**Typical Performance Curves** (Continued)

All performance curves and waveforms are taken with  $C_1 = 4.7\mu\text{F}$ ,  $C_2 = 1\mu\text{F}$ ,  $C_3 = 0.1\mu\text{F}$ ,  $L = 33\mu\text{H}$ ,  $V_{\text{IN}} = 3.3\text{V}$ ,  $V_{\text{CNTL}} = 1\text{V}$ ,  $R_1 = 5\Omega$ , 4 LEDs in a series; unless otherwise specified.

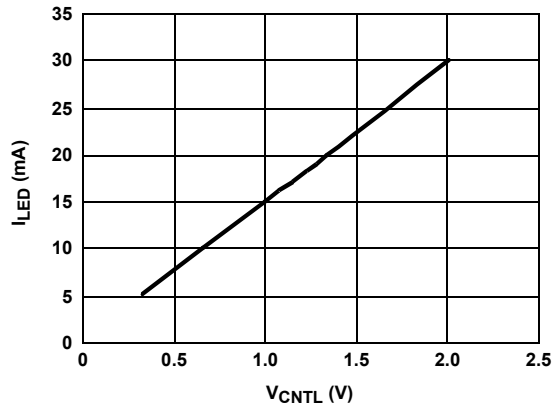

FIGURE 3. I<sub>LED</sub> vs V<sub>CNTL</sub>

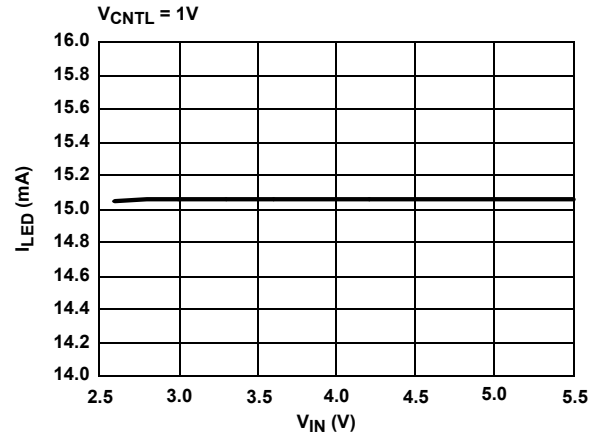

FIGURE 4. I<sub>LED</sub> vs V<sub>IN</sub>

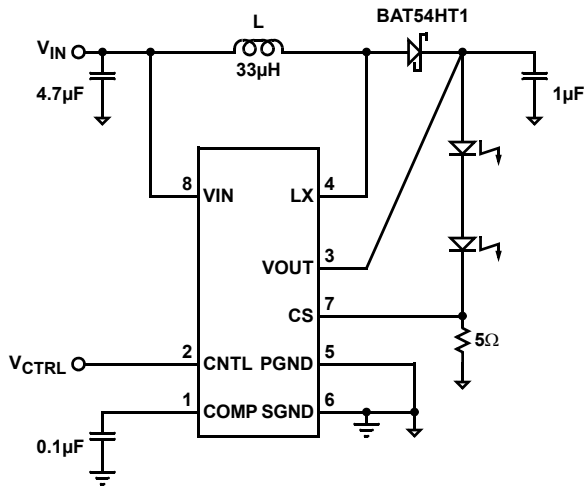

FIGURE 5A. 2 LEDs IN A SERIES

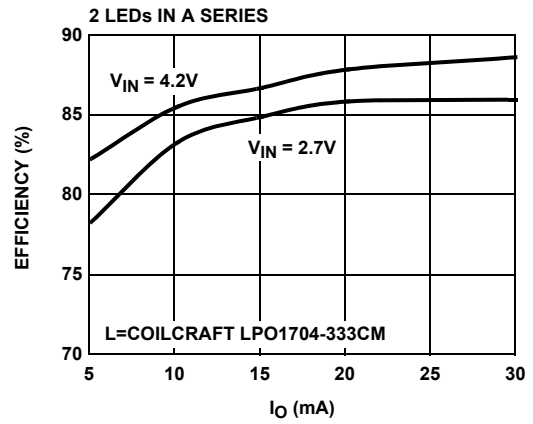

FIGURE 5B. EFFICIENCY vs I<sub>O</sub>

FIGURE 5.

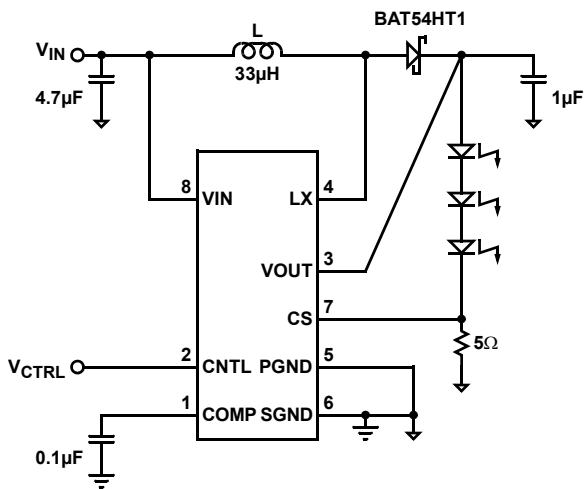

FIGURE 6A. 3 LEDs IN A SERIES

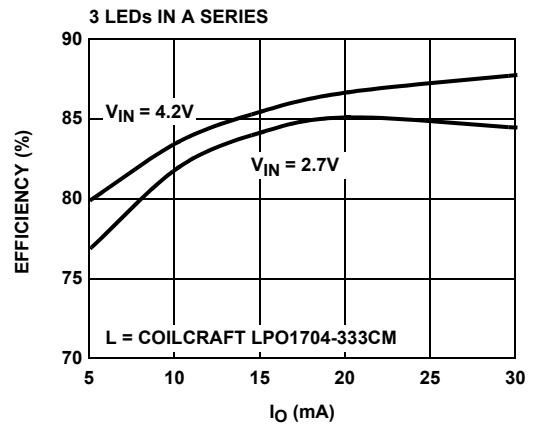

FIGURE 6B. EFFICIENCY vs I<sub>O</sub>

FIGURE 6.

**Typical Performance Curves** (Continued)

All performance curves and waveforms are taken with  $C_1 = 4.7\mu\text{F}$ ,  $C_2 = 1\mu\text{F}$ ,  $C_3 = 0.1\mu\text{F}$ ,  $L = 33\mu\text{H}$ ,  $V_{IN} = 3.3\text{V}$ ,  $V_{CNTL} = 1\text{V}$ ,  $R_1 = 5\Omega$ , 4 LEDs in a series; unless otherwise specified.

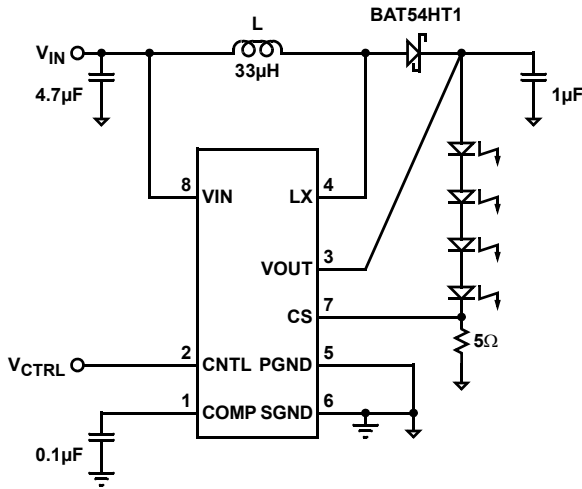

FIGURE 7A. 4 LEDs IN A SERIES

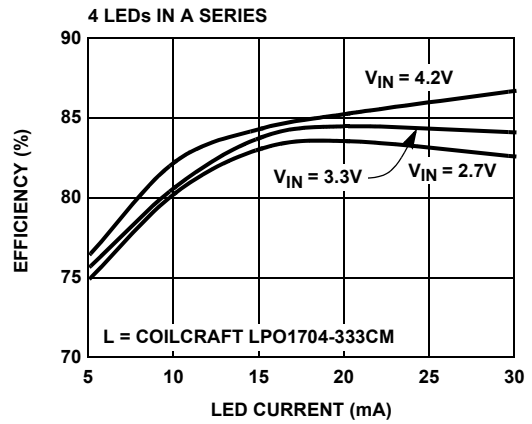

FIGURE 7.

FIGURE 7B. EFFICIENCY vs IO

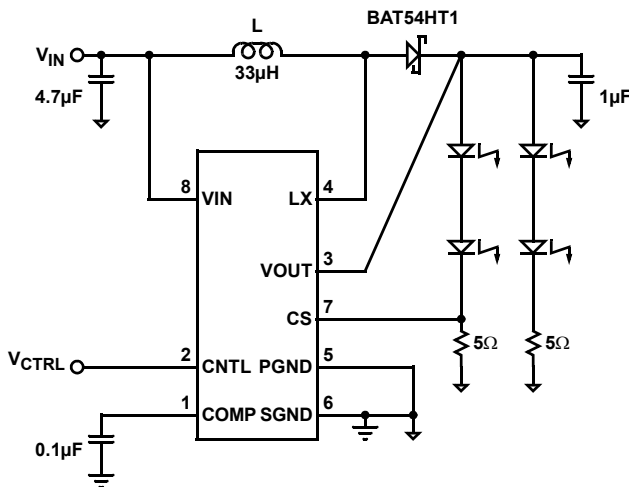

FIGURE 8A. 2 LEGS OF 2 LEDs IN A SERIES

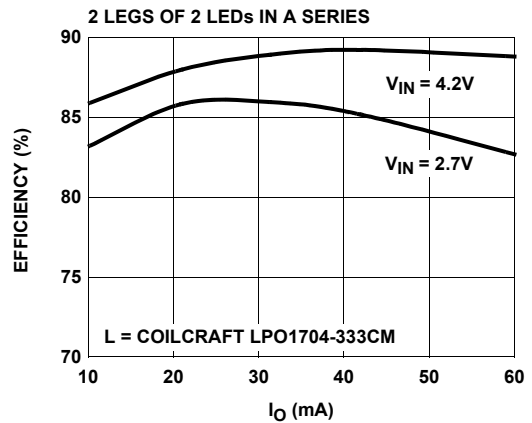

FIGURE 8.

FIGURE 8B. EFFICIENCY vs IO

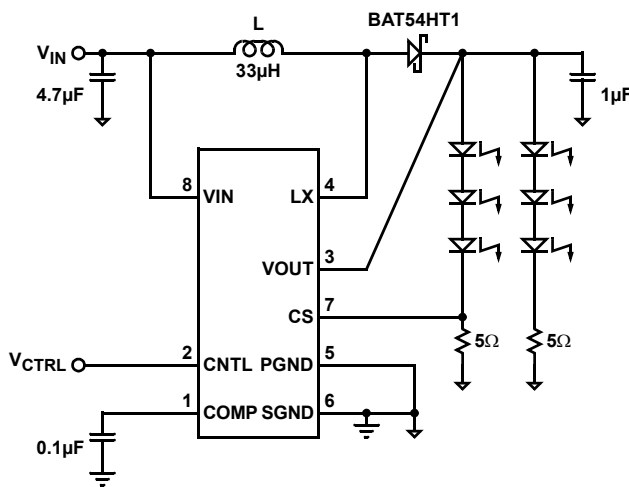

FIGURE 9A. 2 LEGS OF 3 LEDs IN A SERIES

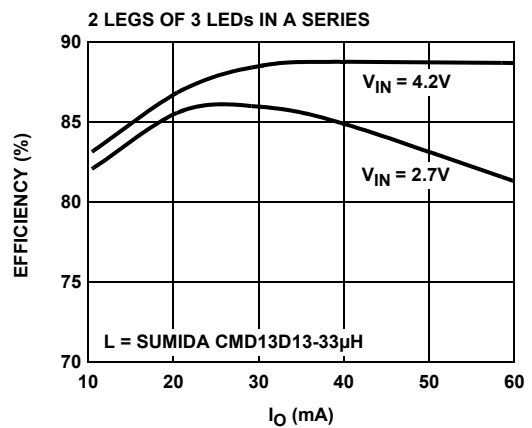

FIGURE 9.

FIGURE 9B. EFFICIENCY vs IO

**Typical Performance Curves** (Continued)

All performance curves and waveforms are taken with  $C_1 = 4.7\mu\text{F}$ ,  $C_2 = 1\mu\text{F}$ ,  $C_3 = 0.1\mu\text{F}$ ,  $L = 33\mu\text{H}$ ,  $V_{IN} = 3.3\text{V}$ ,  $V_{CNTL} = 1\text{V}$ ,  $R_1 = 5\Omega$ , 4 LEDs in a series; unless otherwise specified.

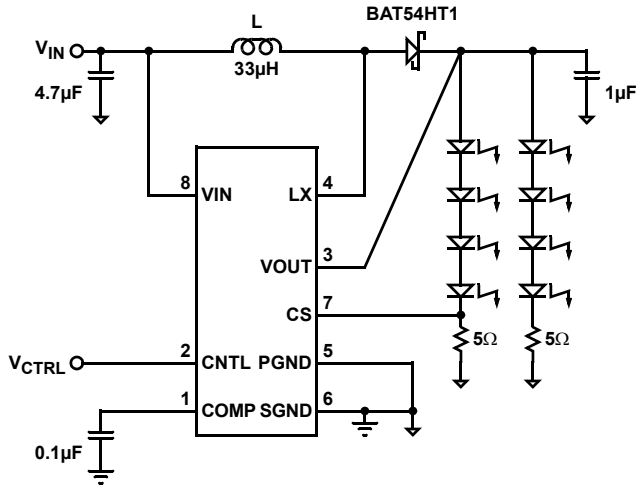

FIGURE 10A. 2 LEGS OF 4 LEDs IN A SERIES

FIGURE 10.

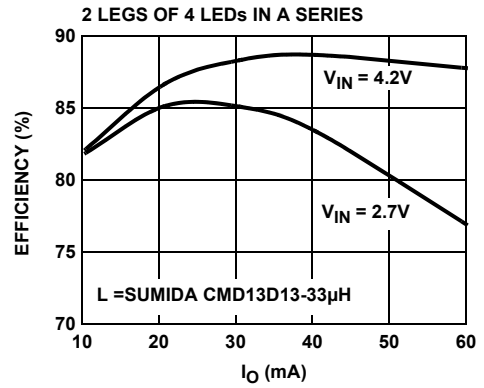

FIGURE 10B. EFFICIENCY vs  $I_O$

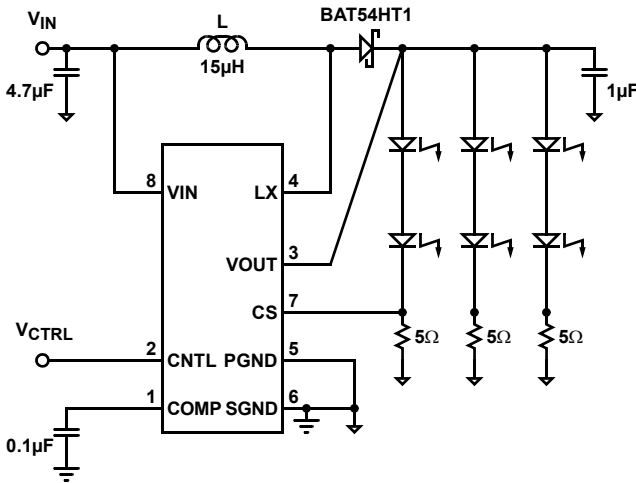

FIGURE 11A. 3 LEGS OF 2 LEDs IN A SERIES

FIGURE 11.

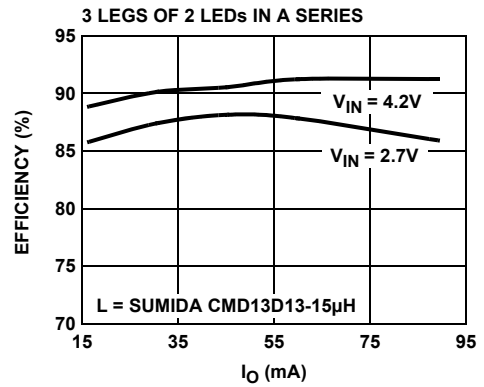

FIGURE 11B. EFFICIENCY vs  $I_O$

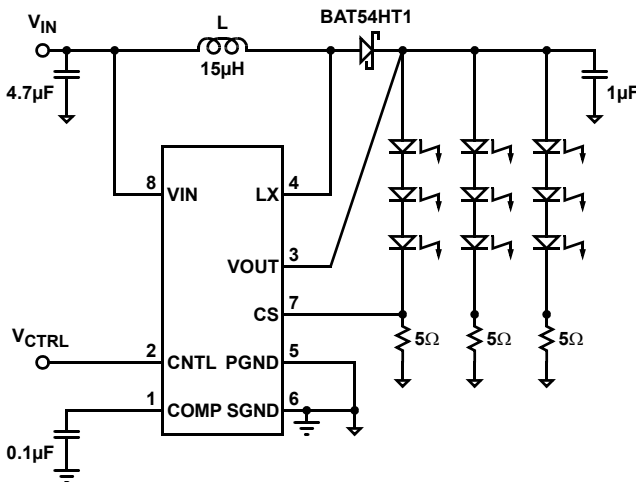

FIGURE 12A. 3 LEGS OF 3 LEDs IN A SERIES

FIGURE 12.

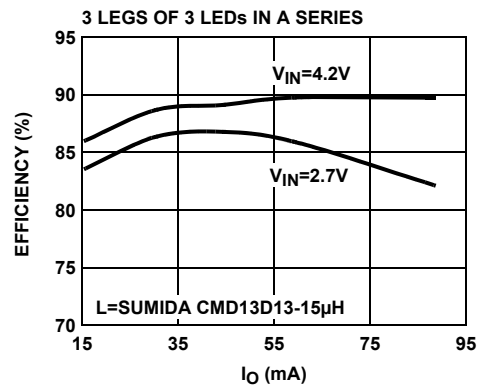

FIGURE 12B. EFFICIENCY vs  $I_O$

**Typical Performance Curves** (Continued)

All performance curves and waveforms are taken with  $C_1 = 4.7\mu\text{F}$ ,  $C_2 = 1\mu\text{F}$ ,  $C_3 = 0.1\mu\text{F}$ ,  $L = 33\mu\text{H}$ ,  $V_{\text{IN}} = 3.3\text{V}$ ,  $V_{\text{CNTL}} = 1\text{V}$ ,  $R_1 = 5\Omega$ , 4 LEDs in a series; unless otherwise specified.

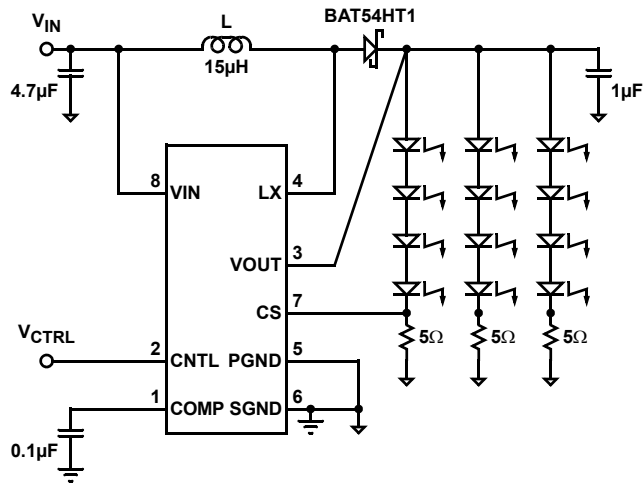

FIGURE 13A. 3 LEGS of 4 LEDs in a SERIES

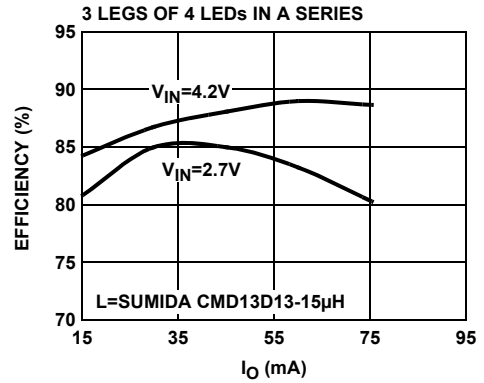

FIGURE 13.

FIGURE 13B. EFFICIENCY vs  $I_O$

**Waveforms**

All performance curves and waveforms are taken with  $C_1 = 4.7\mu\text{F}$ ,  $C_2 = 1\mu\text{F}$ ,  $C_3 = 0.1\mu\text{F}$ ,  $L = 33\mu\text{H}$ ,  $V_{\text{IN}} = 3.3\text{V}$ ,  $V_{\text{CNTL}} = 1\text{V}$ ,  $R_1 = 5\Omega$ , 4 LEDs in a series; unless otherwise specified.

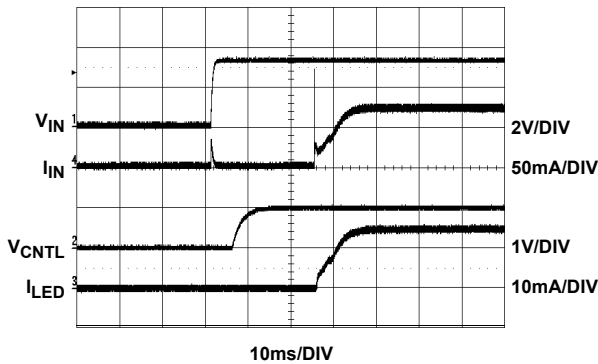

FIGURE 14. START-UP

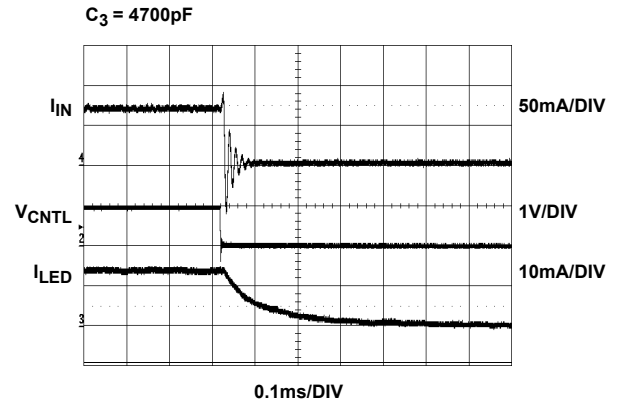

FIGURE 15. SHUT-DOWN

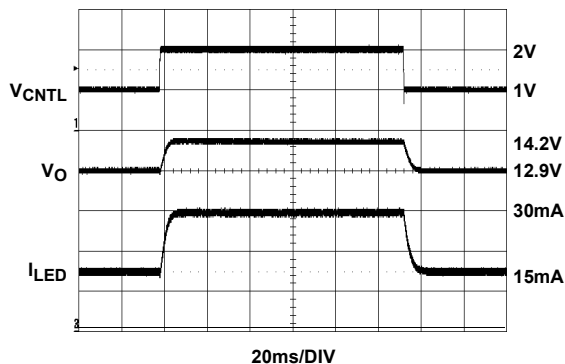

FIGURE 16. TRANSIENT RESPONSE

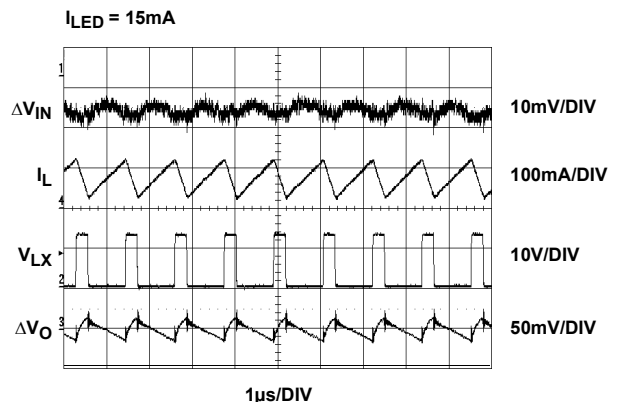

FIGURE 17. CONTINUOUS CONDUCTION MODE

**Waveforms (Continued)**

All performance curves and waveforms are taken with  $C_1 = 4.7\mu\text{F}$ ,  $C_2 = 1\mu\text{F}$ ,  $C_3 = 0.1\mu\text{F}$ ,  $L = 33\mu\text{F}$ ,  $V_{\text{IN}} = 3.3\text{V}$ ,  $V_{\text{CNTL}} = 1\text{V}$ ,  $R_1 = 5\Omega$ , 4 LEDs in a series; unless otherwise specified.

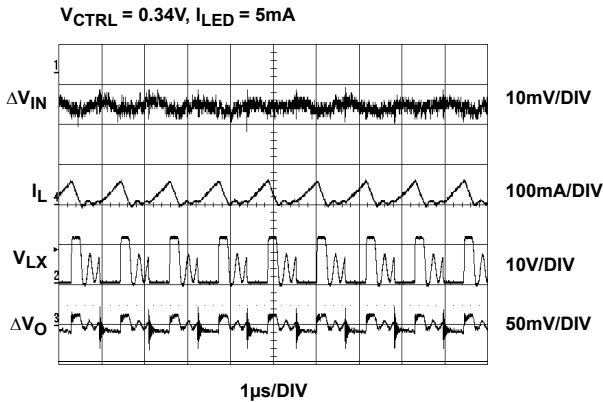

FIGURE 18. DISCONTINUOUS CONDUCTION MODE

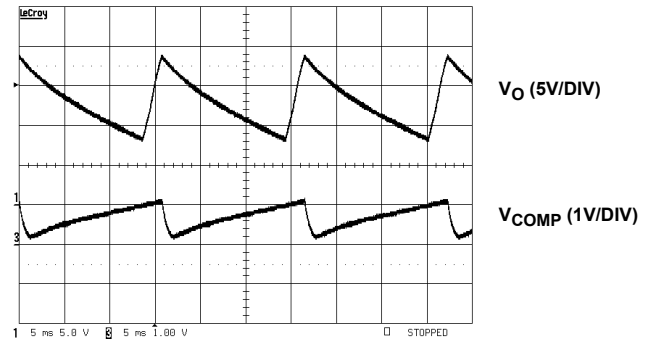

FIGURE 19. OVER VOLTAGE PROTECTION (LED DISCONNECTED)

**Detailed Description**

The EL7513 is a constant current boost regulator specially designed for driving white LEDs. It can drive up to 4 LEDs in series or 12 LEDs in parallel/series configuration and achieves efficiency up to 91%.

The brightness of the LEDs is adjusted through a voltage level on the CNTL pin. When the level falls below 0.1V, the chip goes into shut-down mode and consumes less than 1μA of current for  $V_{\text{IN}}$  less than 5.5V.

**Steady-State Operation**

EL7513 is operated in constant frequency PWM. The switching is around 1MHz. Depending on the input voltage, the inductance, the type of LEDs driven, and the LED's current, the converter operates at either continuous conduction mode or discontinuous conduction mode (see waveforms). Both are normal.

**Brightness Control**

LED's current is controlled by the voltage level on CNTL pin ( $V_{\text{CNTL}}$ ). This voltage can be either a DC or a PWM signal with frequency less than 200Hz (for  $C_3 = 4700\text{pF}$ ). When a higher frequency PWM is used, an RC filter is recommended before the CNTL pin (see Figure 20).

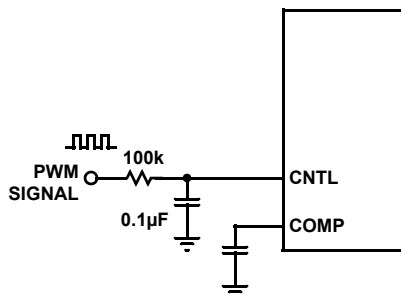

FIGURE 20. PWM BRIGHTNESS CONTROL

The relationship between the LED current and CNTL voltage level is as follows:

$$I_{\text{LED}} = \frac{V_{\text{CNTL}}}{13.33 \times R_1} \tag{EQ. 1}$$

When  $R_1$  is 5Ω, 1V of  $V_{\text{CNTL}}$  conveniently sets  $I_{\text{LED}}$  to 15mA. The range of  $V_{\text{CNTL}}$  is 250mV to 5.5V.

**Shut-Down**

When  $V_{\text{CNTL}}$  is less than 100mV, the converter is in shut-down mode. The max current consumed by the chip is less than 1μA for  $V_{\text{IN}}$  less than 5.5V.

**Over-Voltage Protection**

When an LED string is disconnected from the output,  $V_{\text{O}}$  will continue to rise because of no current feedback. When  $V_{\text{O}}$  reaches 18V (nominal), the chip will shut down. The output voltage will drop. When  $V_{\text{O}}$  drops below 16V (nominal), the chip will boost output voltage again until it reaches 18V. This hiccough continues until LED is applied or converter is shut down.

When designing the converter, caution should be taken to ensure the highest operating LED voltage does not exceed 17V, the minimum shut-down voltage. There is no external component required for this function.

**Component Selection**

The input and output capacitors are not very important for the converter to operate normally. The input capacitance is normally 0.22μF - 4.7μF and output capacitance 0.22μF - 1μF. Higher capacitance is allowed to reduce the voltage/current ripple, but at added cost. Use X5R or X7R type (for its good temperature characteristics) of ceramic capacitors with correct voltage rating and maximum height.

When choosing an inductor, make sure the inductor can handle the average and peak currents giving by following formulas (80% efficiency assumed):

$$I_{LAVG} = \frac{I_O \times V_O}{0.8 \times V_{IN}} \tag{EQ. 2}$$

$$I_{LPK} = I_{LAVG} + \frac{1}{2} \times \Delta I_L \tag{EQ. 3}$$

$$\Delta I_L = \frac{V_{IN} \times (V_O - V_{IN})}{L \times V_O \times F_S} \tag{EQ. 4}$$

where:

- $\Delta I_L$  is the peak-to-peak inductor current ripple in Ampere
- L inductance in  $\mu\text{H}$
- $F_S$  switching frequency, typical 1MHz

A wide range of inductance (6.8 $\mu\text{H}$  - 68 $\mu\text{H}$ ) can be used for the converter to function correctly. For the same series of inductors, the lower inductance has lower DC resistance (DCR), which has less conducting loss. But the ripple current is bigger, which generates more RMS current loss. Figure 11 shows the efficiency of the demo board under different inductance for a specific series of inductor. For optimal efficiency in an application, it is a good exercise to check several adjacent inductance values of your preferred series of inductors.

For the same inductance, higher overall efficiency can be obtained by using lower DCR inductor.

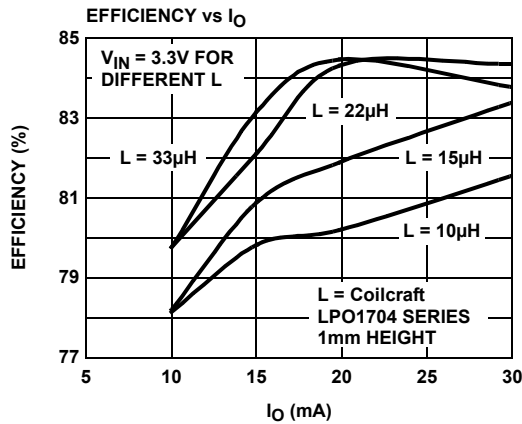

FIGURE 21. EFFICIENCY OF DIFFERENT INDUCTANCE (4 LEDs IN A SERIES)

The diode should be Schottky type with minimum reverse voltage of 20V. The diode's peak current is the same as inductor's peak current, the average current is  $I_O$ , and RMS current is:

$$I_{DRMS} = \sqrt{I_{LAVG} \times I_O} \tag{EQ. 5}$$

Ensure the diode's ratings exceed these current requirements.

**White LED Connections**

One leg of LEDs connected in series will ensure the uniformity of the brightness. 18V maximum voltage enables 4 LEDs can be placed in series.

However, placing LEDs into series/parallel connection can give higher efficiency as shown in the efficiency curves. One of the ways to ensure the brightness uniformity is to pre-screen the LEDs.

**PCB Layout Considerations**

The layout is very important for the converter to function properly. Power Ground ( $\downarrow$ ) and Signal Ground ( $\frac{\perp}{\perp}$ ) should be separated to ensure the high pulse current in the power ground does not interference with the sensitive signals connected to Signal Ground. Both grounds should only be connected at one point right at the chip. The heavy current paths ( $V_{IN}$ -L-LX pin-PGND, and  $V_{IN}$ -L-D-C2-PGND) should be as short as possible.

The trace connected to the CS pin is most important. The current sense resistor  $R_1$  should be very close to the pin. When the trace is long, use a small filter capacitor close to the CS pin.

The heat of the IC is mainly dissipated through the PGND pin. Maximizing the copper area around the plane is preferable. In addition, a solid ground plane is always helpful for the EMI performance.

The demo board is a good example of layout based on the principle. Please refer to the EL7513 Application Brief for the layout.

**TSOT Package Family**

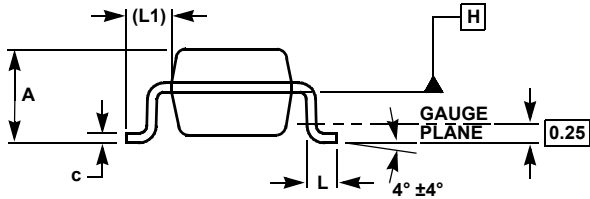
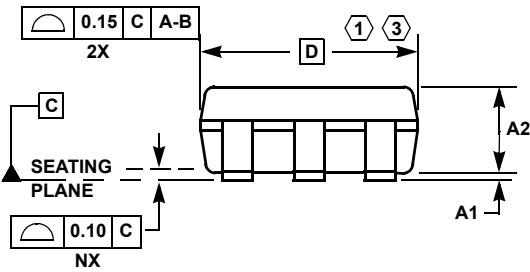
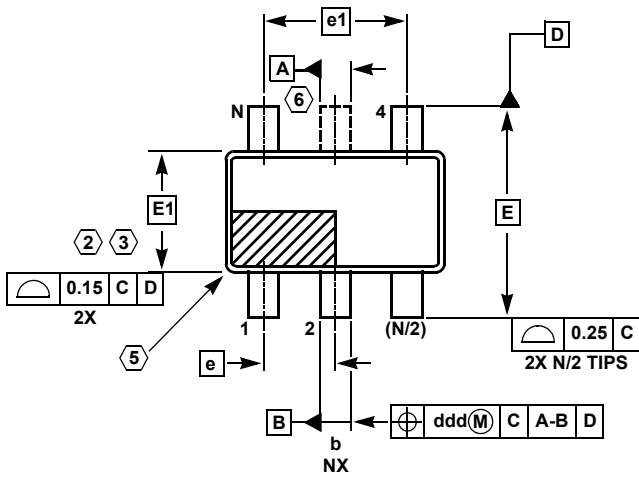

**MDP0049**

**TSOT PACKAGE FAMILY**

SYMBOL	MILLIMETERS			TOLERANCE
	TSOT5	TSOT6	TSOT8	
A	1.00	1.00	1.00	Max
A1	0.05	0.05	0.05	±0.05
A2	0.87	0.87	0.87	±0.03
b	0.38	0.38	0.29	±0.07
c	0.127	0.127	0.127	+0.07/-0.007
D	2.90	2.90	2.90	Basic
E	2.80	2.80	2.80	Basic
E1	1.60	1.60	1.60	Basic
e	0.95	0.95	0.65	Basic
e1	1.90	1.90	1.95	Basic
L	0.40	0.40	0.40	±0.10
L1	0.60	0.60	0.60	Reference
ddd	0.20	0.20	0.13	-
N	5	6	8	Reference

Rev. B 2/07

**NOTES:**

1. Plastic or metal protrusions of 0.15mm maximum per side are not included.
2. Plastic interlead protrusions of 0.15mm maximum per side are not included.
3. This dimension is measured at Datum Plane "H".
4. Dimensioning and tolerancing per ASME Y14.5M-1994.
5. Index area - Pin #1 I.D. will be located within the indicated zone (TSOT6 AND TSOT8 only).
6. TSOT5 version has no center lead (shown as a dashed line).

**Mini SO Package Family (MSOP)**

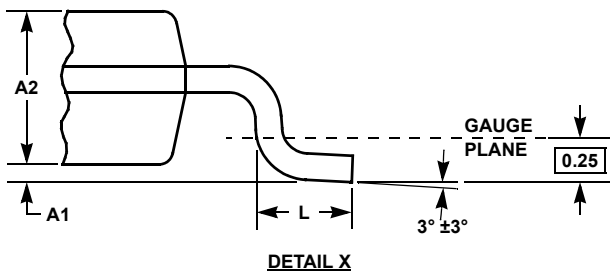
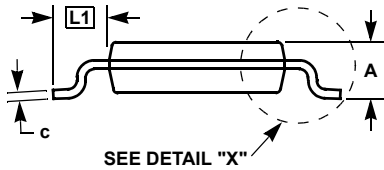
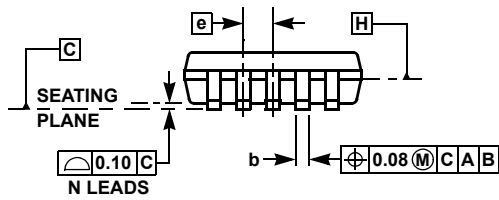
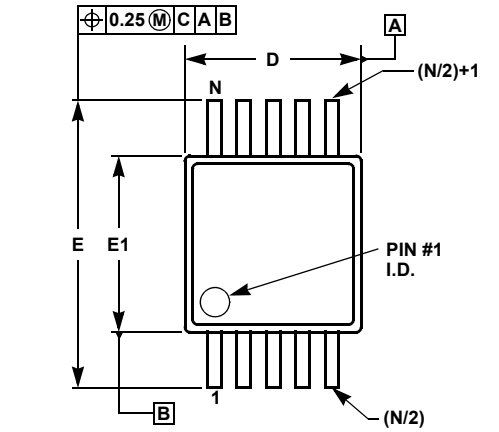

**MDP0043**

**MINI SO PACKAGE FAMILY**

SYMBOL	MILLIMETERS		TOLERANCE	NOTES
	MSOP8	MSOP10		
A	1.10	1.10	Max.	-
A1	0.10	0.10	±0.05	-
A2	0.86	0.86	±0.09	-
b	0.33	0.23	+0.07/-0.08	-
c	0.18	0.18	±0.05	-
D	3.00	3.00	±0.10	1, 3
E	4.90	4.90	±0.15	-
E1	3.00	3.00	±0.10	2, 3
e	0.65	0.50	Basic	-
L	0.55	0.55	±0.15	-
L1	0.95	0.95	Basic	-
N	8	10	Reference	-

Rev. D 2/07

**NOTES:**

1. Plastic or metal protrusions of 0.15mm maximum per side are not included.
2. Plastic interlead protrusions of 0.25mm maximum per side are not included.
3. Dimensions "D" and "E1" are measured at Datum Plane "H".
4. Dimensioning and tolerancing per ASME Y14.5M-1994.

© Copyright Intersil Americas LLC 2004-2008. All Rights Reserved.  
 All trademarks and registered trademarks are the property of their respective owners.

For additional products, see [www.intersil.com/en/products.html](http://www.intersil.com/en/products.html)

Intersil products are manufactured, assembled and tested utilizing ISO9001 quality systems as noted in the quality certifications found at [www.intersil.com/en/support/qualandreliability.html](http://www.intersil.com/en/support/qualandreliability.html)

*Intersil products are sold by description only. Intersil may modify the circuit design and/or specifications of products at any time without notice, provided that such modification does not, in Intersil's sole judgment, affect the form, fit or function of the product. Accordingly, the reader is cautioned to verify that datasheets are current before placing orders. Information furnished by Intersil is believed to be accurate and reliable. However, no responsibility is assumed by Intersil or its subsidiaries for its use; nor for any infringements of patents or other rights of third parties which may result from its use. No license is granted by implication or otherwise under any patent or patent rights of Intersil or its subsidiaries.*

For information regarding Intersil Corporation and its products, see [www.intersil.com](http://www.intersil.com)

## Looking for pricing, stock, or lifecycle information?

Click below to explore more details on WIN SOURCE:

-  [View EL7513IWTZ-T7 on WIN SOURCE](#)
-  [Renesas Electronics America](#) Information

## Optimize Your Supply Chain with WIN SOURCE Solutions

-  Global Sourcing Solution
-  Obsolete Management
-  Cost Control Management
-  Shortage Management
-  Alternative Solution
-  Excess Inventory Management