





THE DATASHEET OF SOD4004



SPECIFICATION SHEET

| | |
|--------------------------------|---|
| SPECIFICATION SHEET NO. | P1102- SOD123F4004SD4 |
| DATE | Nov. 02, 2022 |
| REVISION | A0 |
| DESCRIPTION | SMD General Purpose Silicon Rectifier, SOD-123FL series, SOD4004 Type, 2 Pads Reverse Voltage 400V Max. Forward Current 1.0A Max. Operating Temp. Range -55°C ~+150°C Package in Tape/Reel, 3000pcs/Reel RoHS/RoHS III compliant |
| CUSTOMER | |
| CUSTOMER PART NUMBER | |
| CROSS REF. PART NUMBER | |
| ORIGINAL PART NUMBER | MDD SOD4004 |
| PART CODE | SOD123F4004SD4 |

| | | | |
|-------------------------|---|--|---|
| VENDOR APPROVE | | | |
| Issued/Checked/Approved |  |  |  |
| DATE: Nov. 02, 2022 | | | |

| | |
|-------------------------|--|
| CUSTOMER APPROVE | |
| | |
| DATE: | |

11/2/2022

SMD GENERAL PURPOSE RECTIFIER SOD123FL SERIES



MAIN FEATURE

- Glass Passivated Device
- Ideal For SMT Applications
- Low Reverse Leakage
- Metallurgically Bonded Construction
- High Temperature Soldering Guaranteed:
250°C/10 Seconds, 0.375”(9.5mm) Lead Length, 5 Lbs. (2.3kg) Tension

APPLICATION

- For printed circuit board

RFQ

Request For Quotation

PART CODE GUIDE

| SOD123F | 4004 | S | D4 |
|---------|------|---|----|
| 1 | 2 | 3 | 4 |

- 1) **SOD123F**: SMD General Purpose Silicon Rectifier, SOD-123FL series,
- 2) **4004**: Type Code for original part number SOD4004
- 3) **S**: Package code, Tape/reel, 3000pcs/reel.
- 4) **D4**: Marking code for “D4” on the case surface, Different Marking for different specification..

MORE ITEMS AVAILABLE

| | | | | |
|----------------|----------------|----------------|-----------------------|----------------|
| SOD123F4001SD1 | SOD123F4002SD2 | SOD123F4003SD3 | SOD123F4004SD4 | SOD123F4005SD5 |
| SOD123F4006SD6 | SOD123F4007SD7 | | | |

SMD GENERAL PURPOSE RECTIFIER SOD123FL SERIES

DIMENSION (Unit: Inch/mm)

Image for reference



Marking: D4

SOD-123FL

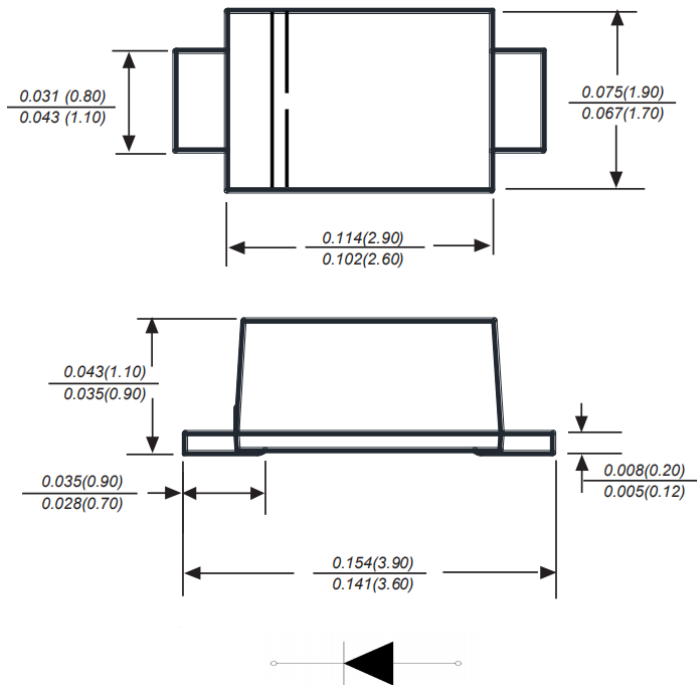

Recommend Pad Layout

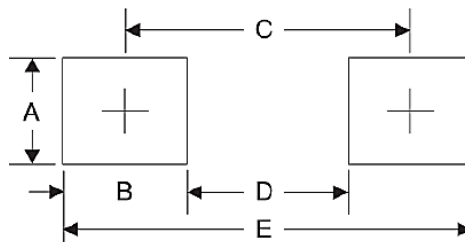

| Symbol | Unit (Inch) | Unit (mm) |
|--------|-------------|-----------|
| A | 0.047 | 1.20 |
| B | 0.047 | 1.20 |
| C | 0.126 | 3.20 |
| D | 0.079 | 2.00 |
| E | 0.173 | 4.40 |

SMD GENERAL PURPOSE RECTIFIER SOD123FL SERIES
MECHANICAL DATA

| Case | Terminals | Polarity | Mounting Position | Weight per piece |
|-------------------------------------|--|---------------------------------|-------------------|---------------------------|
| JEDEC SOD-123FL molded plastic body | Solder plated, Solderable per MIL-STD-750, Method 2026 | Polarity symbol marking on body | Any | 0.0007 Ounce, 0.020 grams |

MAX. RATING & CHARACTERISTICS

| Parameter | SYMBOLS | VALUE | | | UNITS |
|--|------------------|-------|---------|------|-------|
| | | Min. | Typical | Max. | |
| Repetitive peak reverse voltage | V _{RRM} | | | 400 | Volts |
| RMS voltage | V _{RMS} | | | 280 | Volts |
| DC blocking voltage | V _{DC} | | | 400 | Volts |
| Average forward output rectified current | I _{AV} | | | 1.0 | A |
| Peak forward surge current 8.3ms single half sine-wave superimposed on rated load (JEDEC Method) | I _{FSM} | | | 30 | A |
| Instantaneous forward voltage at 1.0A | V _F | | | 1.1 | Volts |
| DC reverse current at rated DC blocking voltage | I _R | | | 5.0 | μA |
| | | | | 50 | μA |
| Junction capacitance (Note 2) | C _J | | 8 | | pF |
| Thermal resistance (Note 3) | R _{QJA} | | 90 | | °C/W |
| Operating junction temperature range | T _J | -55 | | +150 | °C |
| Storage temperature range | T _{STG} | -55 | | +150 | °C |

Note

- Ratings at 25 C ambient temperature unless otherwise specified. Single phase half-wave 60Hz, resistive or inductive load, for capacitive load current derate by 20%.
- Averaged over any 20ms period.
- Measured at 1.0MHz and applied reverse voltage of 4.0Voltage
- Thermal resistance from junction to ambient at 0.375" (9.5mm)lead length, P.C.B. mounted

11/2/2022

SMD GENERAL PURPOSE RECTIFIER SOD123FL SERIES
RELIABILITY

| Number | Experiment Items | Experiment Method And Conditions | Reference Documents |
|--------|------------------------------------|--|---------------------------------|
| 1 | Solder Resistance Test | Test 260°C± 5°C for 10 ± 2 sec. Immerse body into solder 1/16" ± 1/32" | MIL-STD-750D METHOD-2031.2 |
| 2 | Solderability Test | 230°C ±5°C for 5 sec. | MIL-STD-750D METHOD-2026.1 0 |
| 3 | Pull Test | 1 kg in axial lead direction for 10 sec. | MIL-STD-750D METHOD-2036.4 |
| 4 | Bend Test | 0.5Kg Weight Applied To Each Lead, Bending Arcs 90 °C ± 5 °C For 3 Times | MIL-STD-750D METHOD-2036.4 |
| 5 | High Temperature Reverse Bias Test | TA=100°C for 1000 Hours at VR=80% Rated VR | MIL-STD-750D METHOD-1038.4 |
| 6 | Forward Operation Life Test | TA=25°C Rated Average Rectified Current | MIL-STD-750D METHOD-1027.3 |
| 7 | Intermittent Operation Life Test | On state: 5 min with rated IRMS Power Off state: 5 min with Cool Forced Air. On and off for 1000 cycles. | MIL-STD-750D METHOD-1036.3 |
| 8 | Pressure Cooker Test | 15 PSIG, TA=121°C, 4 hours | MIL-S-19500 APPENOIXC |
| 9 | Temperature Cycling Test | -55°C~+125°C; 30 Minutes For Dwelled Time 5 minutes for transferred time. Total: 10 cycles. | MIL-STD-750D METHOD-1051.7 |
| 10 | Thermal Shock Test | 0°C for 5 minutes., 100°C for 5minutes, Total: 10 cycles | MIL-STD-750D METHOD-1056.7 |
| 11 | Forward Surge Test | 8.3ms Single Sale Sine-wave One Surge. | MIL-STD-750D METHOD-4066.4 |
| 12 | Humidity Test | TA=65°C, RH=98% for 1000 hours. | MIL-STD-750D METHOD-1021.3 |
| 13 | High Temperature Storage life Test | 150°C for 1000 Hours | MIL-STD-750D METHOD-1031.5 |

SMD GENERAL PURPOSE RECTIFIER SOD123FL SERIES

SUGGESTED REFLOW PROFILE (For Reference Only)

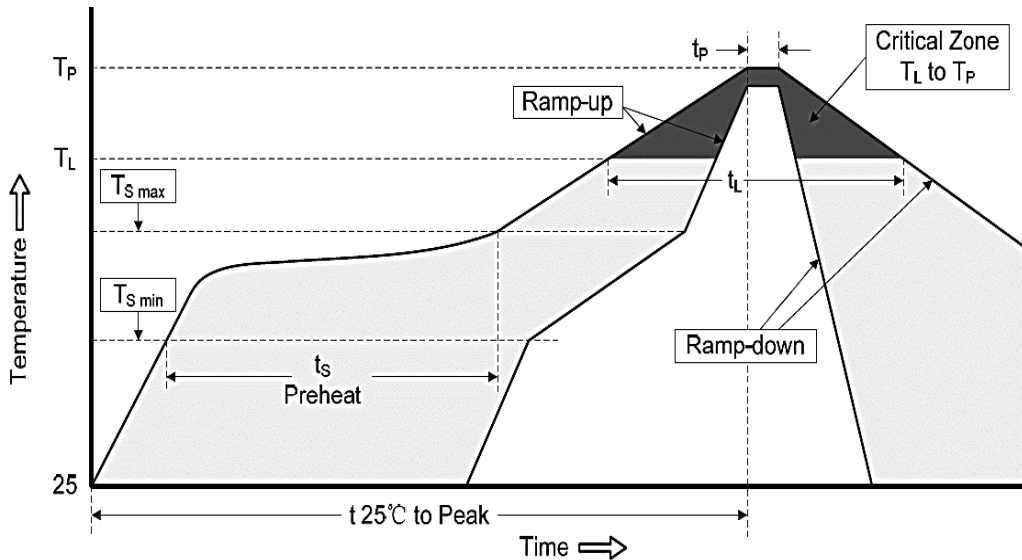

| | | |
|--|----------------------------------|-------------------|
| Profile Feature | | Pb-Free Assembly |
| Average Ramp-up Rate (Ts Max to Tp) | | 3°C/second Max |
| Preheat | Temperature Min (Ts Min.) | 150°C |
| | Temperature Max (Ts Max.) | 200°C |
| | Time (ts Min. to ts Max.) | 60 ~ 180 seconds |
| Time maintained above | Temperature (Tl) | 217°C |
| | Time (tl) | 60 ~ 150 seconds |
| Peak/Classification Temperature (Tp) | | 260 °C |
| Time within 5°C of actual Peak Temperature (tp) | | 20 ~ 40 seconds |
| Ramp-down rate | | 6 °C /Second Max. |
| Time 25 °C to Peak Temperature | | 8 minutes Max. |
| Suggest reflow times | | 3 Times Max. |

SMD GENERAL PURPOSE RECTIFIER SOD123FL SERIES

RATINGS AND CHARACTERISTIC CURVES (For Reference Only)

Fig.1 Forward Current Derating Curve

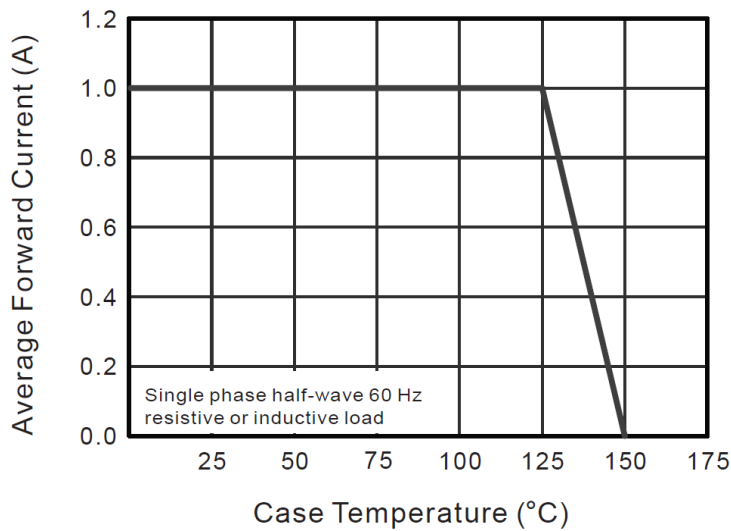
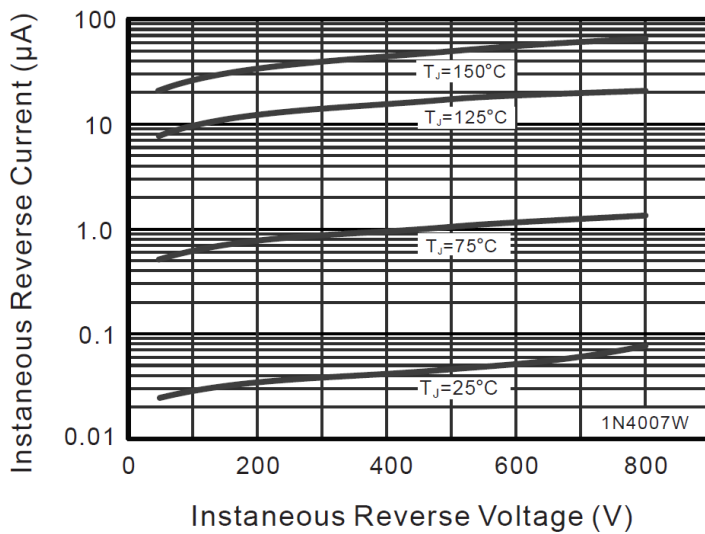

Fig.2 Typical Instaneous Reverse Characteristics



SMD GENERAL PURPOSE RECTIFIER SOD123FL SERIES

RATINGS AND CHARACTERISTIC CURVES (For Reference Only)

Fig.3 Typical Forward Characteristic

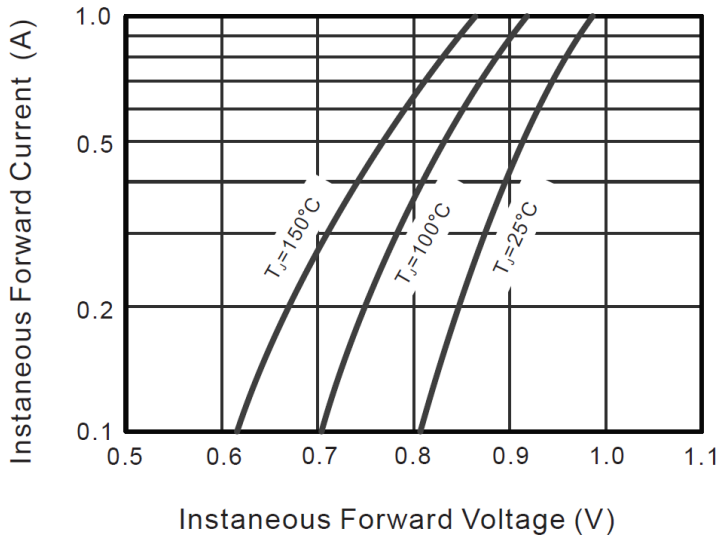
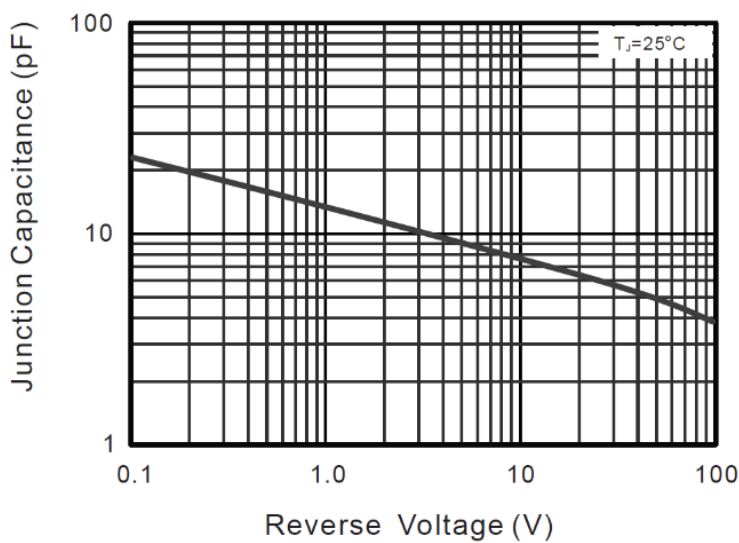

Fig.4 Typical Junction Capacitance



SMD GENERAL PURPOSE RECTIFIER SOD123FL SERIES

RATINGS AND CHARACTERISTIC CURVES (For Reference Only)

Fig.5 Maximum Non-Repetitive Peak Forward Surge Current

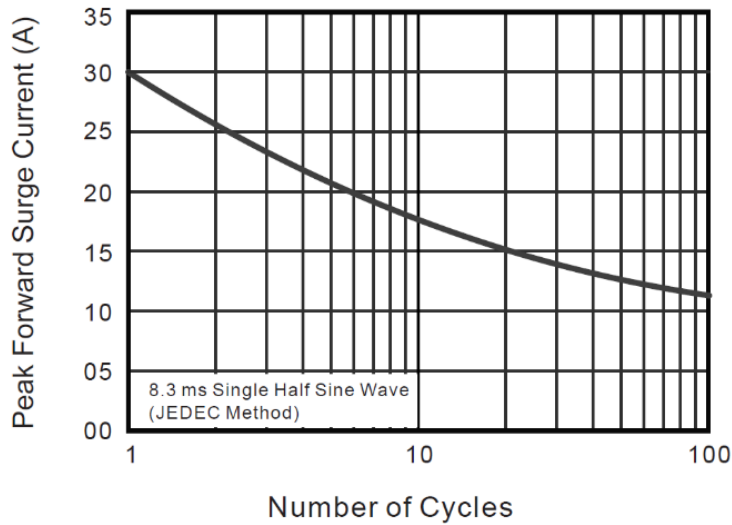

SMD GENERAL PURPOSE RECTIFIER SOD123FL SERIES

TAPE/REEL (Unit: mm)

All Devices are packed in accordance with EIA standard RS-481-A and specifications.

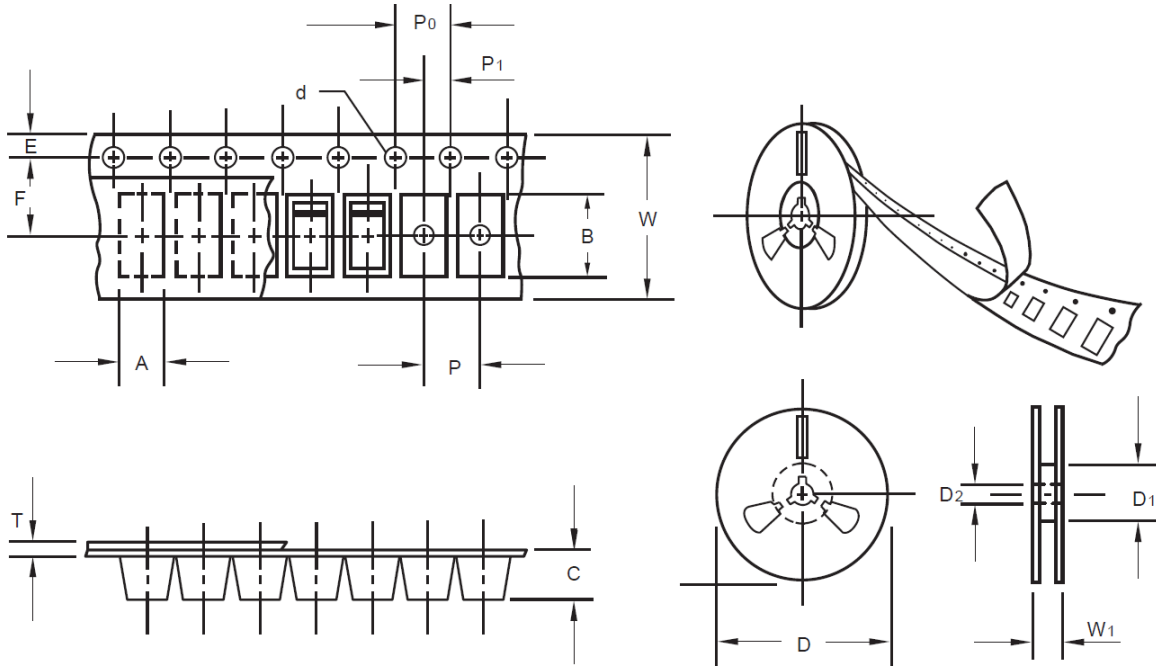

| Item | Symbol | Tolerance | SOD-123FL |
|-------------------------|--------|-----------|-----------|
| Carrier width | A | 0.1 | 2.10 |
| Carrier Length | B | 0.1 | 4.00 |
| Carrier Depth | C | 0.1 | 1.60 |
| Sprocket hole | d | 0.05 | 1.55 |
| 7"Reel outside diameter | D | 2.0 | 178.00 |
| 7"Reel inner diameter | D1 | Min. | 50.00 |
| Feed hole diameter | D2 | 0.5 | 13.00 |
| Sprocket hole position | E | 0.1 | 1.75 |
| Punch hole position | F | 0.1 | 3.50 |
| Punch hole pitch | P | 0.1 | 4.00 |
| Sprocket hole pitch | P0 | 0.1 | 4.00 |
| Embossment center | P1 | 0.1 | 2.00 |
| Overall tape thickness | T | 0.1 | 0.25 |
| Tape width | W | 0.3 | 8.15 |
| Reel width | W1 | 1.0 | 10.50 |

SMD GENERAL PURPOSE RECTIFIER SOD123FL SERIES

PACKAGE For Reference

| | |
|------------------|-----------|
| Case Code | SOD-123FL |
| Reel Size | 7" |
| Reel Size | 178 mm |
| MPQ/Reel | 3000 pcs |
| Qty. /Box | 6000 pcs |
| G.W/Box | 1 lbs |

IMPORTANT NOTICE AND DISCLAIMER

- 1) NextGen Component, Inc. reserves the right to make changes to this document and its products and specifications at any time without notice. Customers should obtain and confirm the latest product information and specifications before final design, purchase or use.
- 2) NextGen Component, Inc makes no warranty, representation or guarantee regarding the suitability of its products for any particular purpose, nor does NextGen Component, Inc assume any liability for application assistance or customer product design.
- 3) NextGen Component, Inc does not warrant or accept any liability with products which are purchased or used for any unintended or unauthorized application. No license is granted by implication or otherwise under any intellectual property rights of NextGen Component, Inc
- 4) NextGen Component, Inc. products are not authorized for use as critical components in life support devices or systems without express written approval of NextGen Component, Inc.







Looking for pricing, stock, or lifecycle information?

Click below to explore more details on WIN SOURCE:

 [View SOD4004 on WIN SOURCE](#)

 [MDD Information](#)

Optimize Your Supply Chain with WIN SOURCE Solutions

-  Global Sourcing Solution
-  Obsolete Management
-  Cost Control Management
-  Shortage Management
-  Alternative Solution
-  Excess Inventory Management