



**THE DATASHEET OF
AD9974BBCZ**



FEATURES

- 1.8 V analog and digital core supply voltage**
- Correlated double sampler (CDS) with**
 - 3 dB, 0 dB, +3 dB, and +6 dB gain
- 6 dB to 42 dB, 10-bit variable gain amplifier (VGA)**
- 14-bit, 65 MHz analog-to-digital converter (ADC)**
- Black level clamp with variable level control**
- Complete on-chip timing generator**
- Precision Timing* core with 240 ps resolution @ 65 MHz**
- On-chip 3 V horizontal and RG drivers**
- 100-lead, 9 mm × 9 mm, 0.8 mm pitch, CSP_BGA package**
- Internal low dropout (LDO) regulator circuitry**

APPLICATIONS

- Professional HDTV camcorders**
- Professional/high end digital cameras**
- Broadcast cameras**
- Industrial high speed cameras**

GENERAL DESCRIPTION

The AD9974 is a highly integrated, dual-channel, charge-coupled device (CCD) signal processor for high speed digital video camera applications. Each channel is specified at pixel rates of up to 65 MHz. The AD9974 consists of a complete analog front end (AFE) with analog-to-digital conversion, combined with a programmable timing driver. The *Precision Timing™* core allows adjustment of high speed clocks with approximately 240 ps resolution at 65 MHz operation.

Each AFE includes black level clamping, CDS, VGA, and a 65 MSPS, 14-bit ADC. The timing driver provides the high speed CCD clock drivers for the RG_A, RG_B, H1_A to H4_A, and H1_B to H4_B outputs. A 3-wire serial interface is used to program each channel of the AD9974.

Available in a space-saving, 9 mm × 9 mm, CSP_BGA package, the AD9974 is specified over an operating temperature range of -25°C to +85°C.

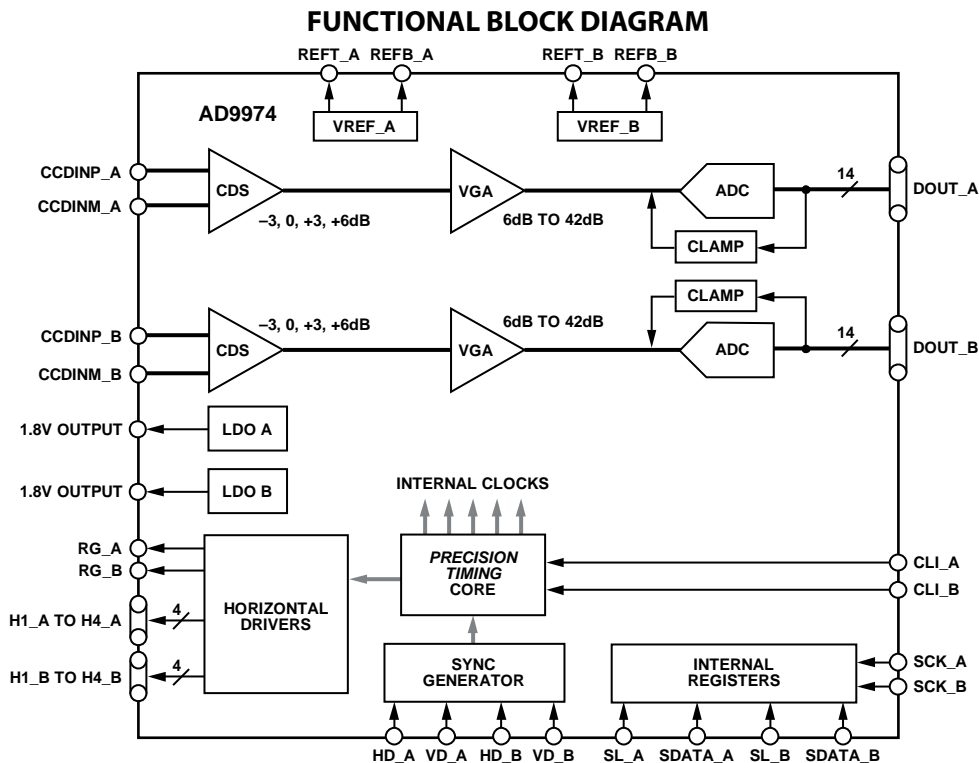

Figure 1.

09695-001

Rev. A

Information furnished by Analog Devices is believed to be accurate and reliable. However, no responsibility is assumed by Analog Devices for its use, nor for any infringements of patents or other rights of third parties that may result from its use. Specifications subject to change without notice. No license is granted by implication or otherwise under any patent or patent rights of Analog Devices. Trademarks and registered trademarks are the property of their respective owners.

TABLE OF CONTENTS

Features	1	<i>Precision Timing</i> High Speed Timing Core.....	15
Applications.....	1	Horizontal Clamping and Blanking.....	18
General Description	1	Complete Field—Combining H-Patterns	25
Functional Block Diagram	1	Mode Registers	26
Revision History	2	Horizontal Timing Sequence Example.....	28
Specifications.....	3	Analog Front End Description and Operation	29
Channel-to-Channel Specifications.....	3	Applications Information	33
Timing Specifications	4	Recommended Power-Up Sequence	33
Digital Specifications	5	Standby Mode Operation.....	36
Analog Specifications.....	6	CLI Frequency Change.....	36
Absolute Maximum Ratings.....	8	Circuit Configuration	37
Thermal Characteristics	8	Grounding and Decoupling Recommendations.....	37
ESD Caution.....	8	3-Wire Serial Interface Timing.....	39
Pin Configuration and Function Descriptions.....	9	Layout of Internal Registers.....	40
Typical Performance Characteristics	11	Updating of Register Values.....	41
Equivalent Input/Output Circuits	12	Complete Register Listing	42
Terminology	13	Outline Dimensions	50
Theory of Operation	14	Ordering Guide	50
Programmable Timing Generation.....	15		

REVISION HISTORY

10/09—Revision A: Initial Version

Changes to Table 1.....	3
Changes to Table 3.....	4
Changes to Pin Function Descriptions Table	9
Changes to Figure 11	12
Changes to Individual HBLK Pattern Section.....	20
Changes to Table 14.....	25
Added Example Register Setting for Power-Up Section	34
Added Additional Restrictions Section	35
Changes to Table 2.....	36
Changes to 3 V System Compatibility Section	37
Changes to Grounding and Decoupling Recommendations Section.....	37
Changes to Table 30.....	48
Changes to Table 31.....	49
Changes to Ordering Guide	50

SPECIFICATIONS

X = A = B, unless otherwise noted.

Table 1.

Parameter	Min	Typ	Max	Unit
TEMPERATURE RANGE				
Operating	-25		+85	°C
Storage	-65		+150	°C
POWER SUPPLY VOLTAGE				
AVDD_X (AFE, Timing Core)	1.6	1.8	2.0	V
RGVDD_X (RG_X Driver)	2.7	3.3	3.6	V
HVDD_X (H1_X to H4_X Drivers)	2.7	3.3	3.6	V
DVDD_X (All Other Digital)	1.6	1.8	2.0	V
DRVDD_X (Parallel Data Output Drivers)	1.6	3.0	3.6	V
IOVDD_X (I/O Supply Without the Use of LDO)	1.6	1.8	3.6	V
POWER SUPPLY CURRENTS—65 MHz OPERATION				
AVDD_X (1.8 V)		55		mA
RGVDD_X (3.3 V, 20 pF RG Load)		5		mA
HVDD_X ¹ (3.3 V, 200 pF Total Load on H1 to H4)		40		mA
DVDD_X (1.8 V)		15		mA
DRVDD_X (3.0 V)		3		mA
IOVDD_X (1.8 V)		2		mA
POWER SUPPLY CURRENTS—STANDBY MODE OPERATION				
Reference Standby		10		mA
Total Shutdown		0.5		mA
LDO ²				
IOVDD_X (I/O Supply When Using LDO)		3.0		V
Output Voltage		1.85		V
Output Current		60	100	mA
CLOCK RATE (CLI)	8		65	MHz

¹ The total power dissipated by the HVDD (or RGVDD) supply can be approximated as follows: $Total\ HVDD\ Power = [C_{LOAD} \times HVDD \times Pixel\ Frequency] \times HVDD$. Reducing the capacitive load and/or reducing the HVDD supply reduces the power dissipation. C_{LOAD} is the total capacitance seen by all H-outputs.

² LDO should be used to supply only AVDD and DVDD.

CHANNEL-TO-CHANNEL SPECIFICATIONS

X = A = B, T_{MIN} to T_{MAX} , $AVDD_X = DVDD_X = 1.8\ V$, $f_{CLI} = 65\ MHz$, typical timing specifications, unless otherwise noted.

Table 2.

Parameter	Min	Typ	Max	Unit	Test Conditions/Comments
LINEARITY MISMATCH ¹		<0.5		%	Absolute value above 1/16 of maximum output code
CROSSTALK ERROR					CDS = 0 dB
Channel A to Channel B		-82		dB	Full-scale step applied to Channel A while measuring response on Channel B
Channel B to Channel A		-82		dB	Full-scale step applied to Channel B while measuring response on Channel A

¹ See the Terminology section for further measurement explanation.

TIMING SPECIFICATIONS

X = A = B, C_L = 20 pF, AVDD_X = DVDD_X = 1.8 V, f_{CLL} = 65 MHz, unless otherwise noted.

Table 3.

Parameter	Min	Typ	Max	Unit	Comments
MASTER CLOCK (CLI)					See Figure 17
CLI Clock Period (t _{CONV})	15.38			ns	
CLI High/Low Pulse Width (t _{ADC})	6.9	7.7	8.9	ns	
Delay from CLI Rising Edge to Internal Pixel Position 0 (t _{CLIDL})		5		ns	
AFE					
SHP Rising Edge to SHD Rising Edge (t _{S1})	6.9	7.7	8.5	ns	See Figure 21
AFE Pipeline Delay		16		Cycles	See Figure 22
CLPOB Pulse Width (Programmable) (t _{COB}) ¹	2	20		Pixels	
HD Pulse Width	t _{CONV}			ns	
VD Pulse Width	1 HD period			ns	
SERIAL INTERFACE					See Figure 52
Maximum SCK Frequency (f _{SCLK})	40			MHz	
SL to SCK Setup Time (t _{LS})	10			ns	
SCK to SL Hold Time (t _{LH})	10			ns	
SDATA Valid to SCK Rising Edge Setup (t _{DS})	10			ns	
SCK Rising Edge to SDATA Valid Hold (t _{DH})	10			ns	
H-COUNTER RESET SPECIFICATIONS					See Figure 49
HD Pulse Width	t _{CONV}			ns	
VD Pulse Width	1 HD period			ns	
VD Falling Edge to HD Falling Edge (t _{VDHD})	0		VD period – t _{CONV}	ns	
HD Falling Edge to CLI Rising Edge (t _{HDCLI})	3		t _{CONV} – 2	ns	
CLI Rising Edge to SHPLOC (Internal Sample Edge) (t _{CLISHP})	3		t _{CONV} – 2	ns	
TIMING CORE SETTING RESTRICTIONS					
Inhibited Region for SHP Edge Location (t _{SHPINH}) (See Figure 21) ²	50		64/0		Edge location
Inhibited Region for SHP or SHD with Respect to H-Clocks (See Figure 21) ^{3, 4, 5, 6}					
RETIME = 0, MASK = 0 (t _{SHDINH})	H × NEGLOC – 15		H × NEGLOC – 0		Edge location
RETIME = 0, MASK = 1 (t _{SHDINH})	H × POSLOC – 15		H × POSLOC – 0		Edge location
RETIME = 1, MASK = 0 (t _{SHPINH})	H × NEGLOC – 15		H × NEGLOC – 0		Edge location
RETIME = 1, MASK = 1 (t _{SHPINH})	H × POSLOC – 15		H × POSLOC – 0		Edge location
Inhibited Region for DOUTPHASE Edge Location (t _{DOUTINH}) (See Figure 21)	SHDLOC + 0		SHDLOC + 15		Edge location

¹ Minimum CLPOB pulse width is for functional operation only. Wider typical pulses are recommended to achieve good clamp performance.

² Only applies to slave mode operation. The inhibited area for SHP is needed to meet the timing requirements for t_{CLISHP} for proper H-counter reset operation.

³ When 0x34[2:0] HxBLKRETIME bits are enabled, the inhibit region for SHD location changes to inhibit region for SHP location.

⁴ When sequence register 0x09[23:21] HBLK masking registers are set to 0, the H-edge reference becomes H × NEGLOC.

⁵ The H-clock signals that have SHP/SHD inhibit regions depend on the HCLK mode: Mode 1 = H1, Mode 2 = H1, H2, and Mode 3 = H1, H3.

⁶ These specifications apply when H1POL, H2POL, RGPOL, and HLPOL are all set to 1 (default setting).

DIGITAL SPECIFICATIONS

X = A = B, IOVDD_X = 1.6 V to 3.6 V, RGVDD_X = HVDD_X = 2.7 V to 3.6 V, C_L = 20 pF, T_{MIN} to T_{MAX}, unless otherwise noted.

Table 4.

Parameter	Min	Typ	Max	Unit	Test Conditions/Comments
LOGIC INPUTS					
High Level Input Voltage (V _{IH})	IOVDD – 0.6			V	
Low Level Input Voltage (V _{IL})			0.6	V	
High Level Input Current (I _{IH})		10		μA	
Low Level Input Current (I _{IL})		10		μA	
Input Capacitance (C _{IN})		10		pF	
LOGIC OUTPUTS					
High Level Output Voltage (V _{OH})	IOVDD – 0.5			V	I _{OH} = 2 mA
Low Level Output Voltage (V _{OL})			0.5	V	I _{OL} = 2 mA
CLI INPUT (CLI_BIAS = 0)					
High Level Input Voltage (V _{IHCLI})	IOVDD/2 + 0.5			V	
Low Level Input Voltage (V _{ILCLI})			IOVDD/2 – 0.5	V	
H-DRIVER OUTPUTS					
High Level Output Voltage at Maximum Current (V _{OH})	HVDD – 0.5			V	
Low Level Output Voltage at Maximum Current			0.5	V	
Maximum Output Current (Programmable) (I _{OL})		30		mA	
Maximum Load Capacitance	100			pF	

AD9974

ANALOG SPECIFICATIONS

X = A = B, AVDD_X = 1.8 V, f_{CL} = 65 MHz, typical timing specifications, T_{MIN} to T_{MAX} , unless otherwise noted.

Table 5.

Parameter	Min	Typ	Max	Unit	Test Conditions/Comments
CDS¹					
Allowable CCD Reset Transient		0.5	0.8	V	
CDS Gain Accuracy					
–3 dB CDS Gain	–3.3	–2.8	–2.3		
0 dB CDS Gain (Default)	–0.7	–0.2	+0.3		
3 dB CDS Gain	2.3	2.8	3.3		
6 dB CDS Gain	4.9	5.4	5.9		
Maximum Input Voltage					VGA gain = 5.6 dB (Code 15, default value)
–3 dB CDS Gain		1.4		V p-p	
0 dB CDS Gain (Default)		1.0		V p-p	
3 dB CDS Gain		0.7		V p-p	
6 dB CDS Gain		0.5		V p-p	
Allowable OB Pixel Amplitude					
0 dB CDS Gain (Default)	–100		+200	mV	
6 dB CDS Gain	–50		+100	mV	
VARIABLE GAIN AMPLIFIER (VGA_X)					
Gain Control Resolution		1024		Steps	
Gain Monotonicity		Guaranteed			
Low Gain Setting (VGA Code 15, Default)		6		dB	
Maximum Gain Setting (VGA Code 1023)		42		dB	
BLACK LEVEL CLAMP					
Clamp Level Resolution		1024		Steps	
Minimum Clamp Level (Code 0)		0		LSB	Measured at ADC output
Maximum Clamp Level (Code 1023)		1023		LSB	Measured at ADC output
ADC (CHN_A and CHN_B)					
Resolution	14			Bits	
Differential Nonlinearity (DNL)	–1.0	±0.5	+1.2	LSB	
No Missing Codes		Guaranteed			
Integral Nonlinearity (INL)		5	15	LSB	
Full-Scale Input Voltage		2.0		V	
VOLTAGE REFERENCE					
Reference Top Voltage (REF_T_X)		1.4		V	
Reference Bottom Voltage (REF_B_X)		0.4		V	
SYSTEM PERFORMANCE					
VGA Gain Accuracy					Specifications include entire signal chain 0 dB CDS gain (default)
Low Gain (Code 15)	5.1	5.6	6.1	dB	Gain = (0.0359 × code) + 5.1 dB
Maximum Gain (Code 1023)	41.3	41.8	42.3	dB	
Peak Nonlinearity, 500 mV Input Signal		0.1	0.4	%	12 dB total gain applied
Total Output Noise		2		LSB rms	AC-grounded input, 6 dB gain applied
Power Supply Rejection (PSR)		48		dB	Measured with step change on supply

¹ Input signal characteristics are defined as shown in Figure 2.

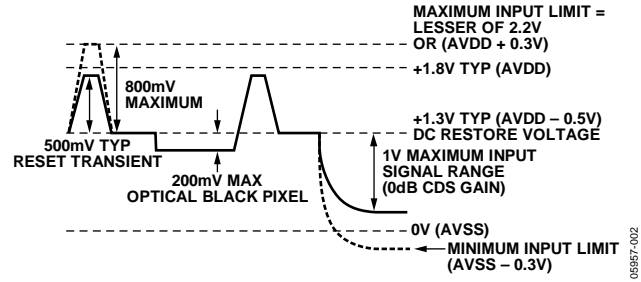

Figure 2. Input Signal Characteristics

ABSOLUTE MAXIMUM RATINGS

Ratings apply to both Channel A and Channel B, unless otherwise noted.

Table 6.

Parameter	Rating
AVDD to AVSS	-0.3 V to +2.2 V
DVDD to DVSS	-0.3 V to +2.2 V
DRVDD to DRVSS	-0.3 V to +3.9 V
IOVDD to DVSS	-0.3 V to +3.9 V
HVDD to HVSS	-0.3 V to +3.9 V
RGVDD to RGVSS	-0.3 V to +3.9 V
Any VSS	-0.3 V to +0.3 V
RG Output to RGVSS	-0.3 V to RGVDD + 0.3 V
H1 to H4, HL Output to HVSS	-0.3 V to HVDD + 0.3 V
SCK, SL, SDI to DVSS	-0.3 V to IOVDD + 0.3 V
REFT, REFB, CCDINM, CCDINP to AVSS	-0.2 V to AVDD + 0.2 V
Junction Temperature	150°C
Lead Temperature (10 sec)	350°C

Stresses above those listed under Absolute Maximum Ratings may cause permanent damage to the device. This is a stress rating only; functional operation of the device at these or any other conditions above those indicated in the operational section of this specification is not implied. Exposure to absolute maximum rating conditions for extended periods may affect device reliability.

THERMAL CHARACTERISTICS

θ_{JA} is measured using a 4-layer PCB with the exposed paddle soldered to the board.

Table 7. Thermal Resistance

Package Type	θ_{JA}	Unit
100-Lead, 9 mm × 9 mm, CSP_BGA	38.3	°C/W

ESD CAUTION



ESD (electrostatic discharge) sensitive device. Charged devices and circuit boards can discharge without detection. Although this product features patented or proprietary protection circuitry, damage may occur on devices subjected to high energy ESD. Therefore, proper ESD precautions should be taken to avoid performance degradation or loss of functionality.

PIN CONFIGURATION AND FUNCTION DESCRIPTIONS

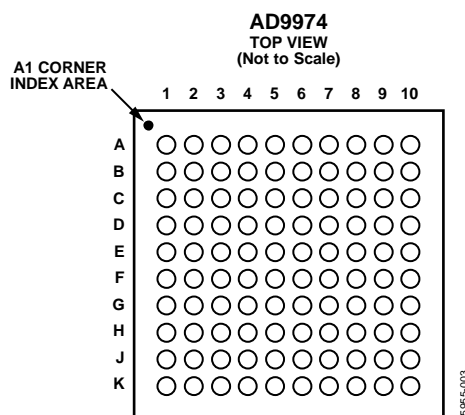

Figure 3. Pin Configuration

Table 8. Pin Function Descriptions

Ball Location	Mnemonic	Type ¹	Description
B2	SL_A	DI	3-Wire Serial Load for Channel A.
C2	SDATA_A	DI	3-Wire Serial Data for Channel A.
D2	SCK_A	DI	3-Wire Serial Clock for Channel A.
C1	REFT_A	AO	Reference with Top Decoupling for Channel A. Decouple with 0.1 μ F to AVSS_A.
D1	REFB_A	AO	Reference with Bottom Decoupling for Channel A. Decouple with 0.1 μ F to AVSS_A.
A1	CCDINM_A	AI	Analog Input for Channel A Image Sensor Signal.
F4	H1_A	DO	CCD Horizontal Clock 1 for Channel A.
F3	H2_A	DO	CCD Horizontal Clock 2 for Channel A.
D4	H3_A	DO	CCD Horizontal Clock 3 for Channel A.
D3	H4_A	DO	CCD Horizontal Clock 4 for Channel A.
B4	RG_A	DO	CCD Reset Gate Clock for Channel A.
J2	DRVSS_A	P	Digital Driver Ground for Channel A.
K3	DRVDD_A	P	Digital Driver Supply for Channel A: 1.8 V or 3.0 V.
E3	HVSS_A	P	H1_A to H4_A Driver Ground for Channel A.
E4	HVDD_A	P	H1_A to H4_A Driver Supply for Channel A: 3.0 V.
C3	RGVSS_A	P	RG_A Driver Ground for Channel A.
C4	RGVDD_A	P	RG_A Driver Supply for Channel A: 3.0 V.
B3	IOVDD_A	P	Digital I/O Supply: 1.8 V or 3.0 V (HD, VD, SL, SCK, SDATA) and LDO Input (3.0 V Only) When LDO Is Used.
A4	CLI_A	DI	Master Clock Input for Channel A.
B1	AVSS_A	P	Analog Ground for Channel A.
A2	CCDINP_A	AI	Analog Input for Channel A Image Sensor Signal.
F2	DVSS_A	P	Digital Ground for Channel A.
F1	DVDD_A	P	Digital Supply for Channel A: 1.8 V.
E2	VD_A	DI	Vertical Sync Pulse for Channel A.
E1	HD_A	DI	Horizontal Sync Pulse for Channel A.
B8	SL_B	DI	3-Wire Serial Load for Channel B.
C8	SDATA_B	DI	3-Wire Serial Data for Channel B.
A5	LDO_OUT_A	P	1.8 V LDO Output from Channel A.
A6	CCDINM_B	AI	Analog Input for Channel B Image Sensor Signal.
D8	SCK_B	DI	3-Wire Serial Clock for Channel B.
C7	REFT_B	AO	Reference with Top Decoupling for Channel B. Decouple with 0.1 μ F to AVSS_B.
D7	REFB_B	AO	Reference with Bottom Decoupling for Channel B. Decouple with 0.1 μ F to AVSS_B.
A7	CCDINP_B	AI	Analog Input for Channel B Image Sensor Signal.
F10	H1_B	DO	CCD Horizontal Clock 1 for Channel B.
F9	H2_B	DO	CCD Horizontal Clock 2 for Channel B.

AD9974

Ball Location	Mnemonic	Type ¹	Description
D10	H3_B	DO	CCD Horizontal Clock 3 for Channel B.
D9	H4_B	DO	CCD Horizontal Clock 4 for Channel B.
B10	RG_B	DO	CCD Reset Gate Clock for Channel B.
J8	DRVSS_B	P	Digital Driver Ground for Channel B.
K9	DRVDD_B	P	Digital Driver Supply for Channel B: 1.8 V or 3.0 V.
E9	HVSS_B	P	H1_B to H4_B Driver Ground for Channel B.
E10	HVDD_B	P	H1_B to H4_B Driver Supply for Channel B: 3.0 V.
C9	RGVSS_B	P	RG_B Driver Ground for Channel B.
C10	RGVDD_B	P	RG_B Driver Supply for Channel B: 3.0 V.
B9	IOVDD_B	P	Digital I/O Supply: 1.8 V or 3.0 V (HD, VD, SL, SCK, SDATA) and LDO Input (3.0 V Only) When LDO Is Used.
A10	LDO_OUT_B	P	1.8 V LDO Output from Channel B.
B7	AVSS_B	P	Analog Ground for Channel B.
A8	AVDD_B	P	Analog Supply for Channel B: 1.8 V.
F8	DVSS_B	P	Digital Ground for Channel B.
F7	DVDD_B	P	Digital Supply for Channel B: 1.8 V.
E8	VD_B	DI	Vertical Sync Pulse for Channel B.
E7	HD_B	DI	Horizontal Sync Pulse for Channel B.
A3	AVDD_A	P	Analog Supply for Channel A: 1.8 V.
G1	D0_A	DO	Data Outputs Channel A.
H1	D1_A	DO	Data Outputs Channel A.
J1	D2_A	DO	Data Outputs Channel A.
K1	D3_A	DO	Data Outputs Channel A.
G2	D4_A	DO	Data Outputs Channel A.
H2	D5_A	DO	Data Outputs Channel A.
K2	D6_A	DO	Data Outputs Channel A.
G3	D7_A	DO	Data Outputs Channel A.
H3	D8_A	DO	Data Outputs Channel A.
J3	D9_A	DO	Data Outputs Channel A.
K4	D10_A	DO	Data Outputs Channel A.
J4	D11_A	DO	Data Outputs Channel A.
H4	D12_A	DO	Data Outputs Channel A.
G4	D13_A	DO	Data Outputs Channel A.
B5, C5, D5, E5, F5, G5, H5, J5, K5, B6, C6, D6, E6, F6, G6, H6, J6, K6	GND	P	Ground Connection.
A9	CLI_B	DI	Master Clock Input for Channel B.
G7	D0_B	DO	Data Outputs Channel B.
H7	D1_B	DO	Data Outputs Channel B.
J7	D2_B	DO	Data Outputs Channel B.
K7	D3_B	DO	Data Outputs Channel B.
G8	D4_B	DO	Data Outputs Channel B.
H8	D5_B	DO	Data Outputs Channel B.
K8	D6_B	DO	Data Outputs Channel B.
G9	D7_B	DO	Data Outputs Channel B.
H9	D8_B	DO	Data Outputs Channel B.
J9	D9_B	DO	Data Outputs Channel B.
K10	D10_B	DO	Data Outputs Channel B.
J10	D11_B	DO	Data Outputs Channel B.
H10	D12_B	DO	Data Outputs Channel B.
G10	D13_B	DO	Data Outputs Channel B.

¹ AI = analog input, AO = analog output, DI = digital input, DO = digital output, P = power.

TYPICAL PERFORMANCE CHARACTERISTICS

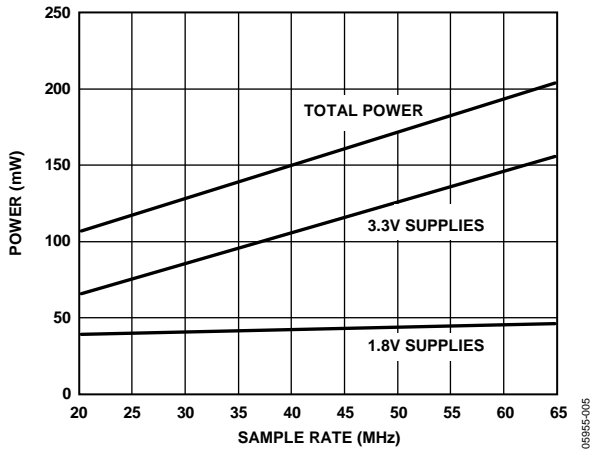

Figure 4. Power vs. Sample Rate

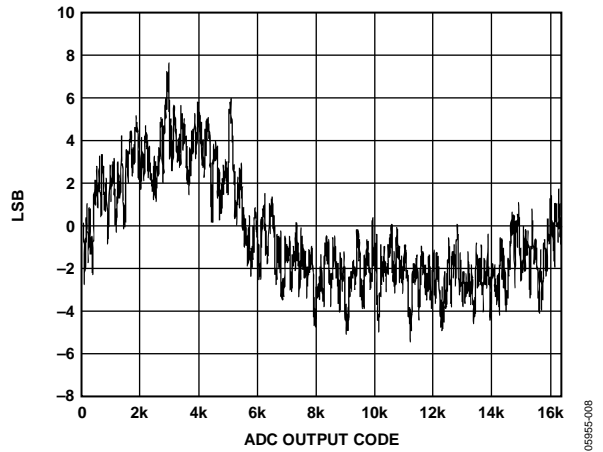

Figure 7. Integral Nonlinearity

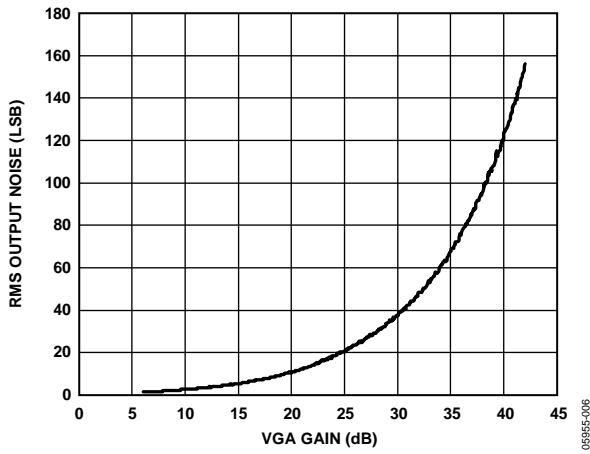

Figure 5. RMS Output Noise vs. VGA Gain

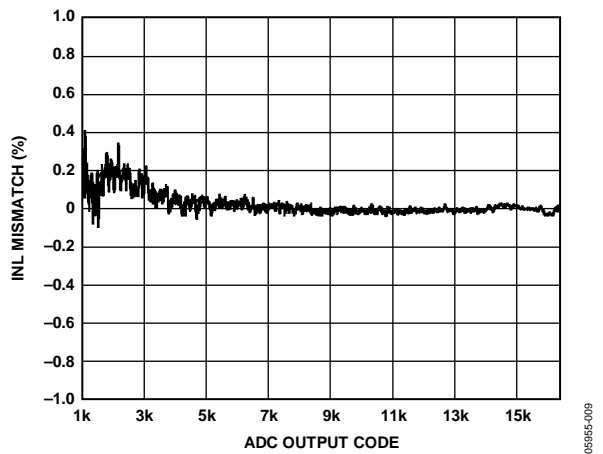

Figure 8. Linearity Mismatch vs. ADC Output Code

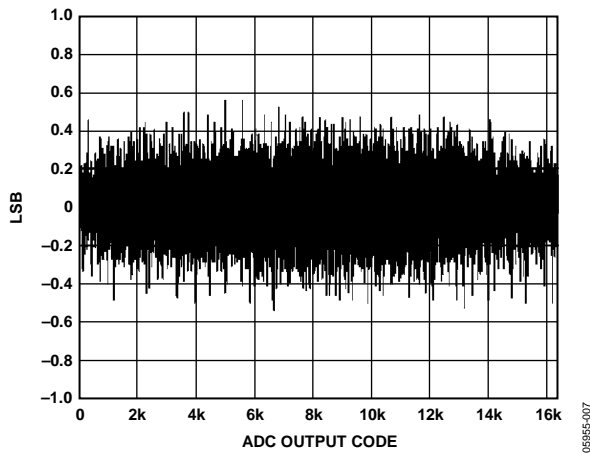

Figure 6. Differential Nonlinearity

EQUIVALENT INPUT/OUTPUT CIRCUITS

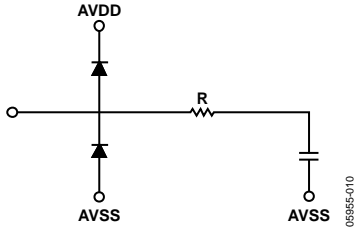

Figure 9. CCDIN Input

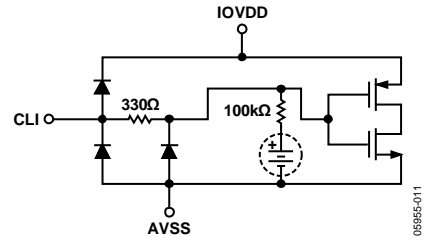

Figure 11. CLI Input, Register 0x15[0] = 1 Enables the Bias Circuit

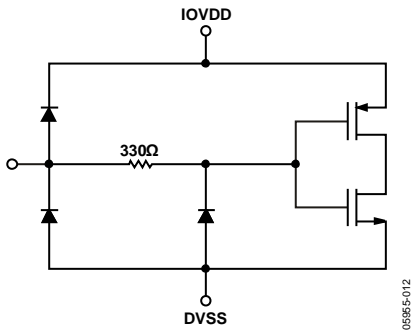

Figure 10. Digital Inputs

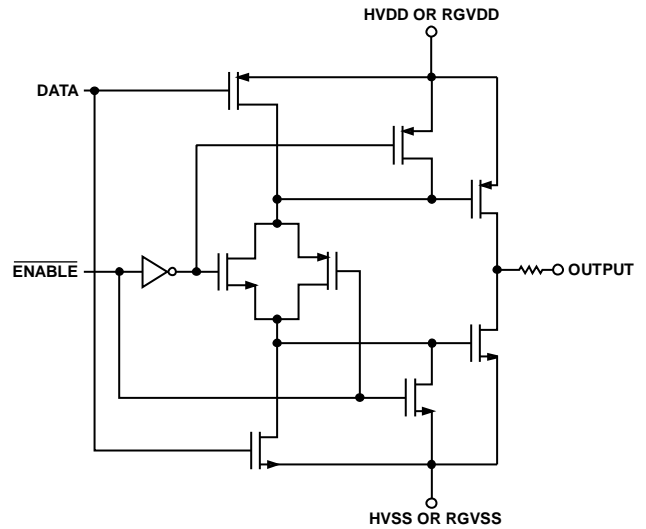

Figure 12. H1 to H4 and RG Outputs

TERMINOLOGY

Differential Nonlinearity (DNL)

An ideal ADC exhibits code transitions that are exactly 1 LSB apart. DNL is the deviation from this ideal value. Therefore, every code must have a finite width. No missing codes guaranteed to 14-bit resolution indicates that all 16,384 codes, each for its respective input, must be present over all operating conditions.

Peak Nonlinearity

Peak nonlinearity, a full signal chain specification, refers to the peak deviation of the output of the AD9974 from a true straight line. The point used as zero scale occurs 0.5 LSB before the first code transition. Positive full scale is defined as a level 1 LSB and 0.5 LSB beyond the last code transition. The deviation is measured from the middle of each particular output code to the true straight line. The error is then expressed as a percentage of the 2 V ADC full-scale signal. The input signal is always appropriately gained up to fill the ADC full-scale range.

Total Output Noise

The rms output noise is measured using histogram techniques. The standard deviation of the ADC output codes is calculated in LSB and represents the rms noise level of the total signal chain at the specified gain setting. The output noise can be converted to an equivalent voltage using the relationship

$$1 \text{ LSB} = (\text{ADC Full Scale} / 2^n \text{ Codes})$$

where n is the bit resolution of the ADC. For the AD9974, 1 LSB is approximately 122.0 μV .

Linearity Mismatch

The linearity mismatch is calculated by taking the difference in INL of the two channels at Input X, and then expressing the difference as a percentage of the output code at X. The values given in Table 2 are obtained over the range of 1/16 and maximum of the output code. The general trend is for the linearity mismatch to decrease as the output approaches the maximum code, as shown in Figure 8.

$$\text{Linearity Mismatch (\%)} = \frac{|INLA(X) - INLB(X)|}{\text{Output Code}(X)}$$

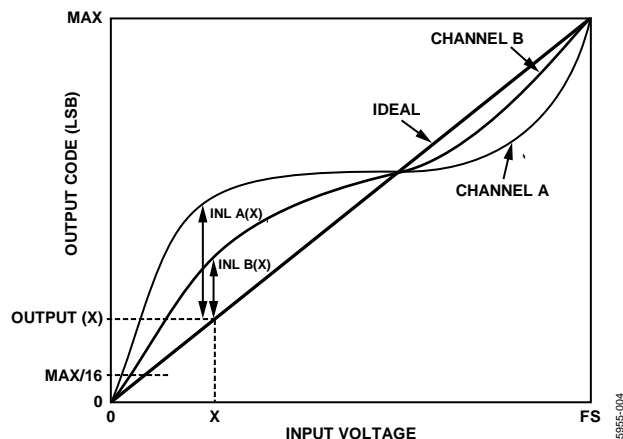

Figure 13. Linearity Mismatch Definition

Power Supply Rejection (PSR)

The PSR is measured with a step change applied to the supply pins. The PSR specification is calculated from the change in the data outputs for a given step change in the supply voltage.

Crosstalk

The crosstalk is measured while applying a full-scale step to one channel and measuring the interference on the opposite channel.

$$\text{Crosstalk (dB)} = 20 \times \log \left(\frac{\text{Interference (LSB)}}{16,384} \right)$$

THEORY OF OPERATION

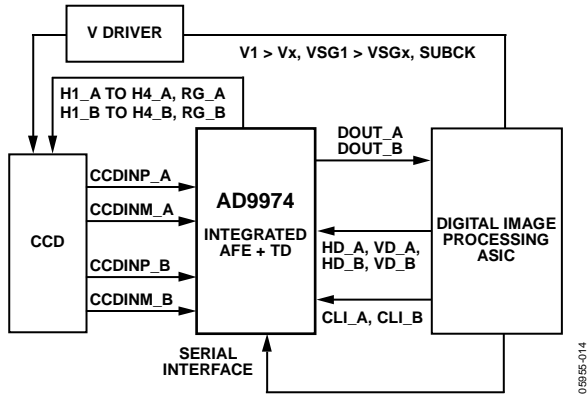

Figure 14. Typical Application

Figure 14 shows the typical system block diagram for the AD9974. The charge-coupled device (CCD) output is processed by the analog front-end (AFE) circuitry of the AD9974, consisting of a CDS, VGA, black level clamp, and ADC. The digitized pixel information is sent to the digital image processor chip, which performs the postprocessing and compression. To operate the CCD, all CCD timing parameters are programmed into the AD9974 from the system ASIC through the 3-wire serial interface. From the system master clock, CLI_X, which is provided by the image processor or external crystal, the AD9974 generates the horizontal clocks of the CCD and all internal AFE clocks.

All AD9974 clocks are synchronized with VD and HD inputs. All of the AD9974 horizontal pulses (CLPOB, PBLK, and HBLK) are programmed and generated internally.

The H-drivers for H1 to H4 and RG are included in the AD9974, allowing these clocks to be directly connected to the CCD. An H-driver voltage of 3 V is supported in the AD9974.

Figure 15 and Figure 16 show the maximum horizontal and vertical counter dimensions for the AD9974. All internal horizontal and vertical clocking is controlled by these counters, which specify line and pixel locations. Maximum HD length is 8191 pixels per line, and maximum VD length is 8191 lines per field.

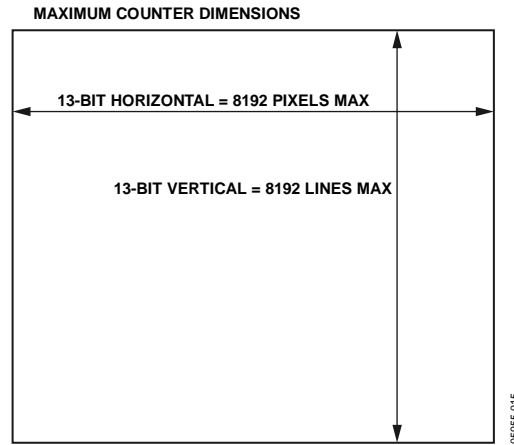

Figure 15. Vertical and Horizontal Counters

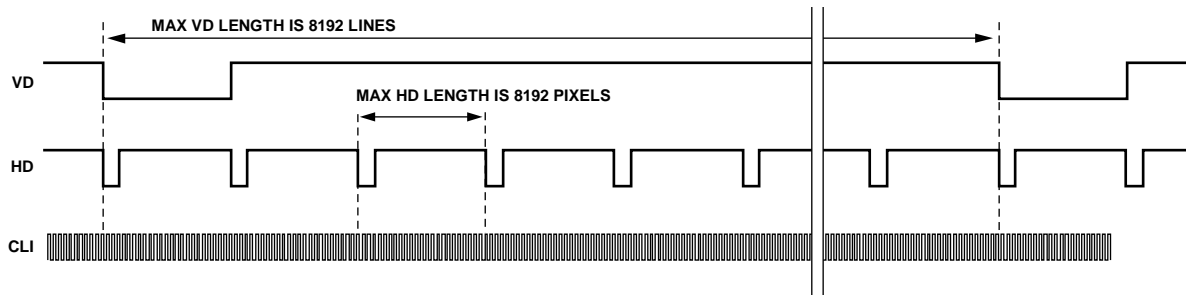

Figure 16. Maximum VD/HD Dimensions

PROGRAMMABLE TIMING GENERATION

PRECISION TIMING HIGH SPEED TIMING CORE

The AD9974 generates flexible high speed timing signals using the *Precision Timing* core. This core, composed of the Reset Gate RG, Horizontal Driver H1 to Horizontal Driver H4, and SHP/SHD sample clocks, is the foundation for generating the timing for both the CCD and the AFE. A unique architecture makes it routine for the system designer to optimize image quality by providing precise control over the horizontal CCD readout and the AFE correlated double sampling.

Timing Resolution

The *Precision Timing* core uses a master clock input (CLI_X) as a reference. This clock input should be the same as the CCD pixel clock frequency. Figure 17 illustrates how the internal timing core divides the master clock period into 64 steps or edge positions; therefore, the edge resolution of the *Precision Timing* core is $(t_{CLI}/64)$. For more information on using the CLI input, refer to the Applications Information section.

Using a 65 MHz CLI frequency, the edge resolution of the *Precision Timing* core is approximately 240 ps. If a 1x system clock is not available, it is possible to use a 2x reference clock by programming the CLIDIVIDE register (Address 0x0D). The AD9974 then internally divides the CLI frequency by 2.

High Speed Clock Programmability

Figure 18 shows when the high speed clocks, RG, H1 to H4, SHP, and SHD, are generated. The RG pulse has programmable rising and falling edges and can be inverted using the polarity control. The H1 and H2 horizontal clocks have separate programmable rising and falling edges, as well as separate polarity control. The AD9974 provides additional HCLK-mode programmability, as described in Table 9.

The edge location registers are each six bits wide, allowing the selection of all 64 edge locations. Figure 21 shows the default timing locations for all of the high speed clock signals.

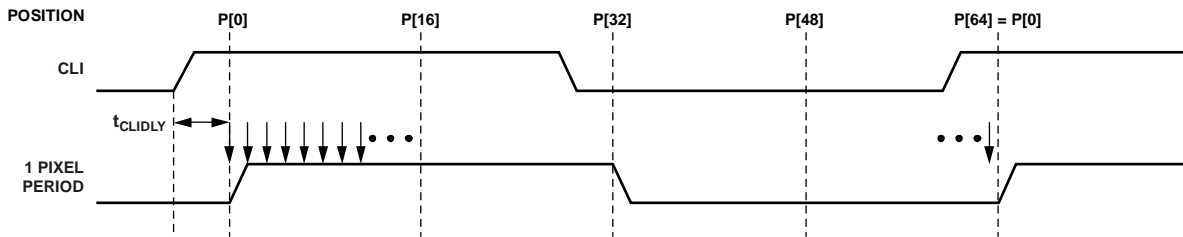

- NOTES
 1. THE PIXEL CLOCK PERIOD IS DIVIDED INTO 64 POSITIONS, PROVIDING FINE EDGE RESOLUTION FOR HIGH SPEED CLOCKS.
 2. THERE IS A FIXED DELAY FROM THE CLI INPUT TO THE INTERNAL PIXEL PERIOD POSITION (t_{CLIDLY}).

Figure 17. High Speed Clock Resolution from CLI Master Clock Input

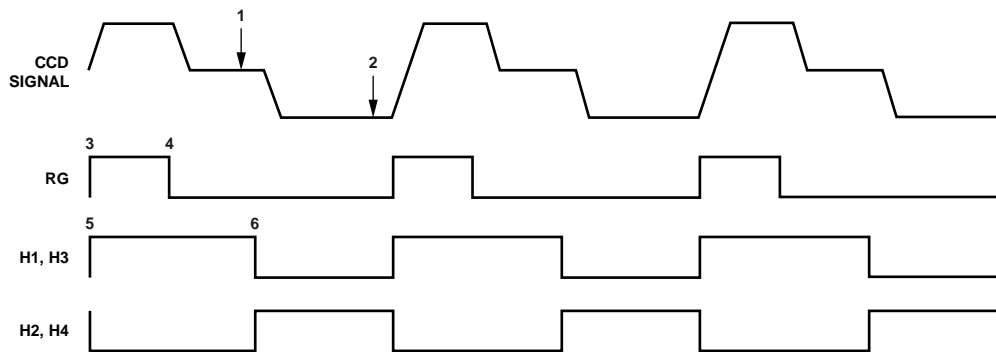

- PROGRAMMABLE CLOCK POSITIONS:
 1SHP SAMPLE LOCATION.
 2SHD SAMPLE LOCATION.
 3RG RISING EDGE.
 4RG FALLING EDGE.
 5H1 RISING EDGE.
 6H1 FALLING EDGE.

Figure 18. High Speed Clock Programmable Locations (HCLK Mode 1)

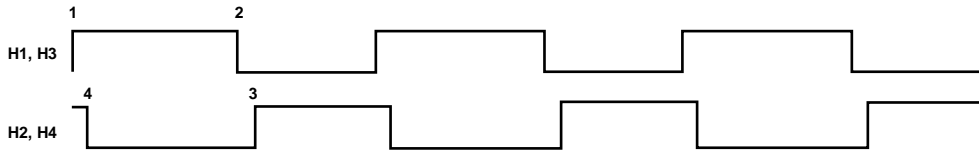

H1 TO H4 PROGRAMMABLE LOCATIONS:
 1H1 RISING EDGE.
 2H1 FALLING EDGE.
 3H2 RISING EDGE.
 4H2 FALLING EDGE.

059955-019

Figure 19. HCLK Mode 2 Operation

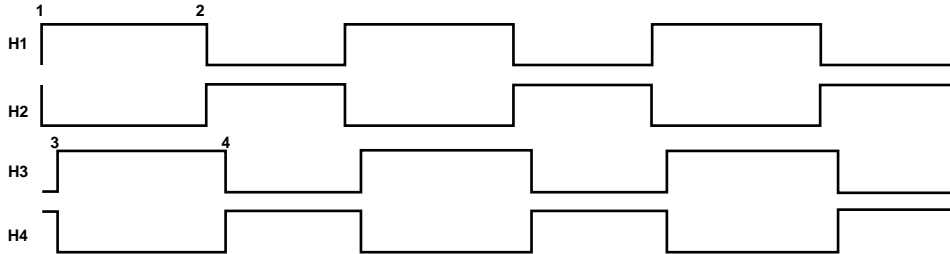

H1 TO H4 PROGRAMMABLE LOCATIONS:
 1H1 RISING EDGE.
 2H1 FALLING EDGE.
 3H3 RISING EDGE.
 4H3 FALLING EDGE.

059955-020

Figure 20. HCLK Mode 3 Operation

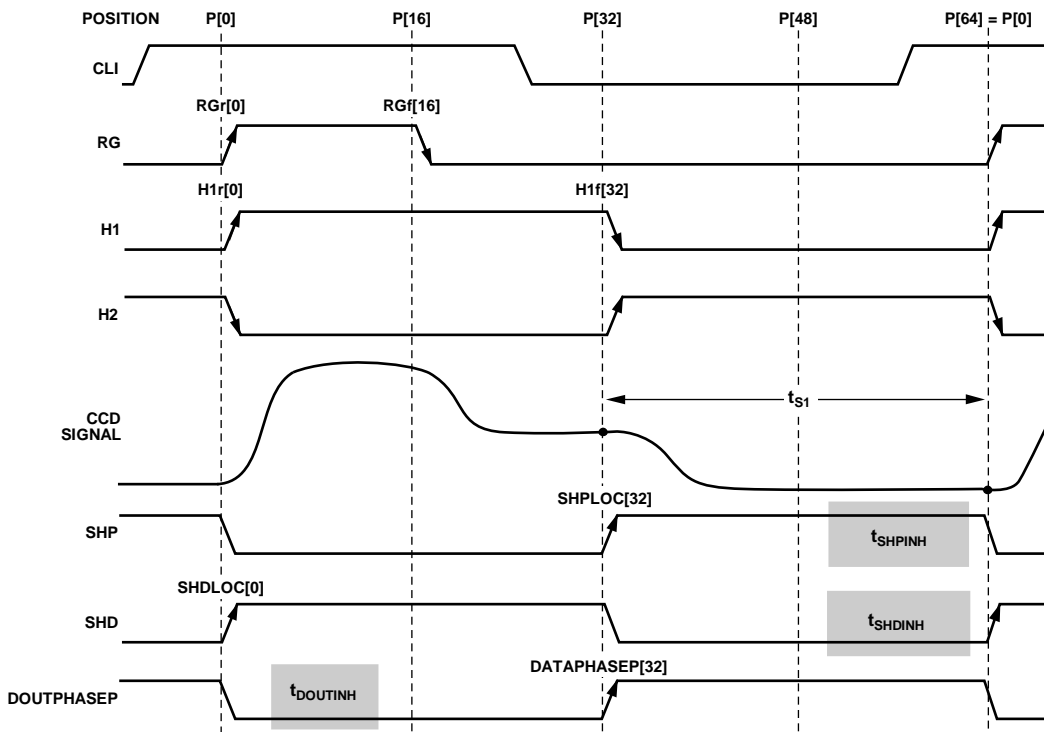

- NOTES
1. ALL SIGNAL EDGES ARE FULLY PROGRAMMABLE TO ANY OF THE 64 POSITIONS WITHIN ONE PIXEL PERIOD. TYPICAL POSITIONS FOR EACH SIGNAL ARE SHOWN. HCLK MODE 1 IS SHOWN.
 2. CERTAIN POSITIONS SHOULD BE AVOIDED FOR EACH SIGNAL, SHOWN ABOVE AS INHIBIT REGIONS.
 3. IF A SETTING IN THE INHIBIT REGION IS USED, AN UNSTABLE PIXEL SHIFT CAN OCCUR IN THE HBLK LOCATION OR AFE PIPELINE.

059955-021

Figure 21. High Speed Timing Default Locations

Table 9. HCLK Modes, Selected by HCLKMODE Register (Address 0x23[7:5])

HCLK Mode	Register Value	Description
Mode 1	001	H1 edges are programmable, with H3 = H1 and H2 = H4 = inverse of H1.
Mode 2	010	H1 edges are programmable, with H3 = H1. H2 edges are programmable, with H4 = H2.
Mode 3	100	H1 edges are programmable, with H2 = inverse of H1. H3 edges are programmable, with H4 = inverse of H3.
Invalid Selection	000, 011, 101, 110, 111	Invalid register settings.

Table 10. H1, H2, RGCONTROL, DRVCONTROL, and SAMPCONTROL Register Parameters

Parameter	Length (Bits)	Range	Description
Polarity	1	High/low	Polarity control for H1/H3 and RG. 0 = no inversion. 1 = inversion.
Positive Edge	6	0 to 63 edge location	Positive edge location for H1/H3 and RG.
Negative Edge	6	0 to 63 edge location	Negative edge location for H1/H3 and RG.
Sample Location	6	0 to 63 sample location	Sampling location for SHP and SHD.
Drive Control	3	0 to 7 current steps	Drive current for H1 to H4 and RG outputs, 0 to 7 steps of 4.3 mA each.

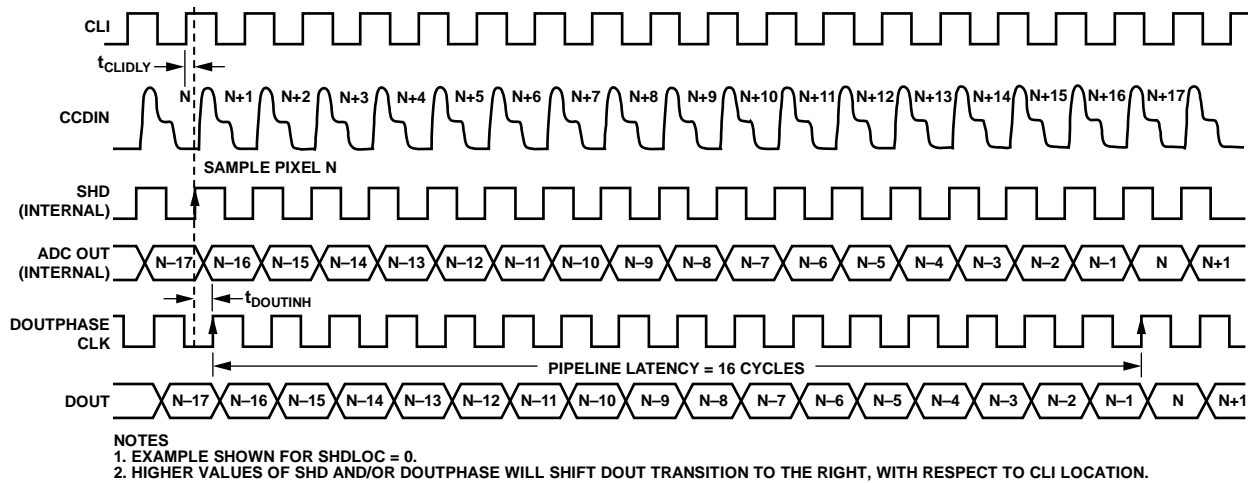

Figure 22. Pipeline Delay of AFE Data Outputs

H-Driver and RG Outputs

In addition to the programmable timing positions, the AD9974 features on-chip output drivers for the RG and H1 to H4 outputs. These drivers are powerful enough to drive the CCD inputs directly. The H-driver and RG-driver current can be adjusted for optimum rise/fall time into a particular load by using the drive strength control registers (Address 0x35). Use the register to adjust the drive strength in 4.3 mA increments. The minimum setting of 0 is equal to off or three-state, and the maximum setting of 7 is equal to 30.1 mA.

Digital Data Outputs

For maximum system flexibility, the AD9974 uses the DOUTPHASE registers (Address 0x37[11:0]) to select the location for the start of each new pixel data value. Any edge location from 0 to 63 can be programmed. These registers determine the start location of the data output and the DCLK rising edge with respect to the master clock input, CLI_X.

The pipeline delay through the AD9974 is shown in Figure 22. After the CCD input is sampled by SHD, there is a 16-cycle delay until the data is available.

HORIZONTAL CLAMPING AND BLANKING

The horizontal clamping and blanking pulses of the AD9974 are fully programmable to suit a variety of applications. Individual control is provided for CLPOB, PBLK, and HBLK during the different regions of each field. This allows the dark pixel clamping and blanking patterns to be changed at each stage of the readout to accommodate different image transfer timing and high speed line shifts.

Individual CLPOB and PBLK Patterns

The AFE horizontal timing consists of CLPOB and PBLK, as shown in Figure 23. These two signals are programmed independently using the registers in Table 11. The start polarity for the CLPOB or PBLK signal is CLPOB_POL (PBLK_POL), and the first and second toggle positions of the pulse are CLPOB_TOG1 (PBLK_TOG1) and CLPOB_TOG2 (PBLK_TOG2). Both signals are active low and need to be programmed accordingly.

Two separate patterns for CLPOB and PBLK can be programmed for each H-pattern, CLPOB0, CLPOB1, PBLK0, and PBLK1. The CLPOB_PAT and PBLK_PAT field registers select which of the two patterns is used in each field.

Figure 34 shows how the sequence change positions divide the readout field into different regions. By assigning a different H-pattern to each region, the CLPOB and PBLK signals can change with each change in the vertical timing.

CLPOB and PBLK Masking Area

Additionally, the AD9974 allows the CLPOB and PBLK signals to be disabled during certain lines in the field without changing any of the existing pattern settings. There are three sets of start and end registers for both CLPOB and PBLK that allow the creation of up to three masking areas for each signal.

For example, to use the CLPOB masking, program the CLPOBMASKSTART and CLPOBMASKEND registers to specify the starting and ending lines in the field where the CLPOB patterns are to be ignored. Figure 24 illustrates this feature.

The masking registers are not specific to a certain H-pattern; they are always active for any existing field of timing. To disable the CLPOB and PBLK masking feature, set these registers to the maximum value of 0x1FFF.

Note that to disable CLPOB and PBLK masking during power-up, it is recommended that CLPOBMASKSTART (PBLKMASKSTART) be set to 8191 and CLPOBMASKEND (PBLKMASKEND) be set to 0. This prevents any accidental masking caused by different register update events.

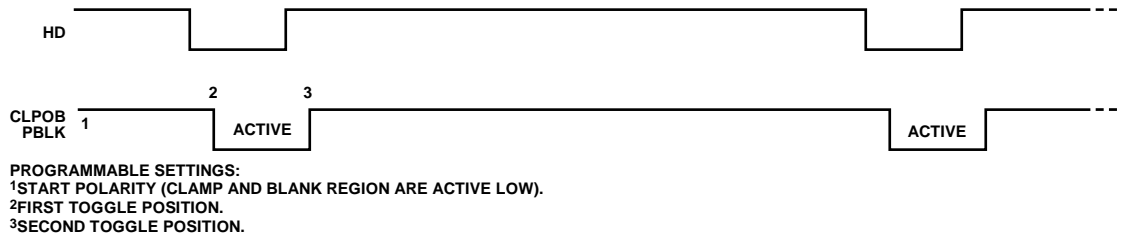

Figure 23. Clamp and Preblank Pulse Placement

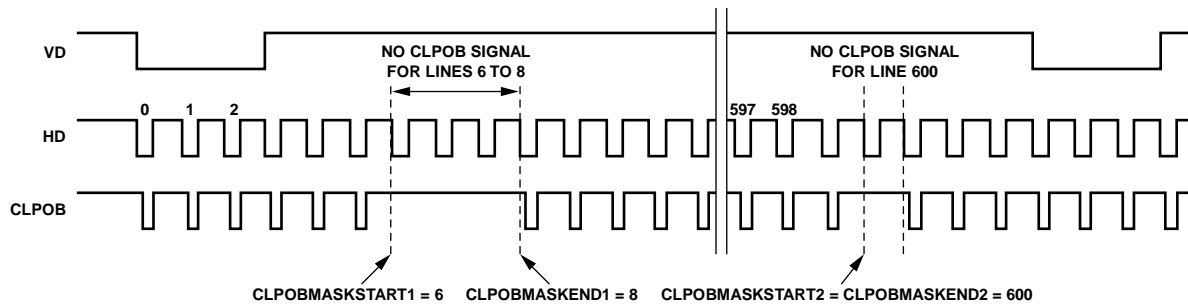

Figure 24. CLPOB Masking Example

Table 11. CLPOB and PBLK Pattern Registers

Parameter	Length (Bits)	Range	Description
CLPOB0_TOG1	13	0 to 8191 pixel location	First CLPOB0 toggle position within the line for each V-sequence.
CLPOB0_TOG2	13	0 to 8191 pixel location	Second CLPOB0 toggle position within the line for each V-sequence.
CLPOB1_TOG1	13	0 to 8191 pixel location	First CLPOB1 toggle position within the line for each V-sequence.
CLPOB1_TOG2	13	0 to 8191 pixel location	Second CLPOB1 toggle position within the line for each V-sequence.
CLPOB_POL	9	High/low	Starting polarity of CLPOB for each V-sequence [8:0] (in field registers).
CLPOB_PAT	9	0 to 9 settings	CLPOB pattern selection for each V-sequence [8:0] (in field registers).
CLPOBMASKSTART	13	0 to 8191 pixel location	CLPOB mask start position: three values available (in field registers).
CLPOBMASKEND	13	0 to 8191 pixel location	CLPOB mask end position: three values available (in field registers).
PBLK0_TOG1	13	0 to 8191 pixel location	First PBLK0 toggle position within the line for each V-sequence.
PBLK0_TOG2	13 </td <td>0 to 8191 pixel location</td> <td>Second PBLK0 toggle position within the line for each V-sequence.</td>	0 to 8191 pixel location	Second PBLK0 toggle position within the line for each V-sequence.
PBLK1_TOG1	13	0 to 8191 pixel location	First PBLK1 toggle position within the line for each V-sequence.
PBLK1_TOG2	13	0 to 8191 pixel location	Second toggle position within the line for each V-sequence.
PBLK_POL	9	High/low	Starting polarity of PBLK for each V-sequence [8:0] (in field registers).
PBLK_PAT	9	0 to 9 settings	PBLK pattern selection for each V-sequence [8:0] (in field registers).
PBLKMASKSTART	13	0 to 8191 pixel location	PBLK mask start position: three values available (in field registers).
PBLKMASKEND	13	0 to 8191 pixel location	PBLK mask end position: three values available (in field registers).

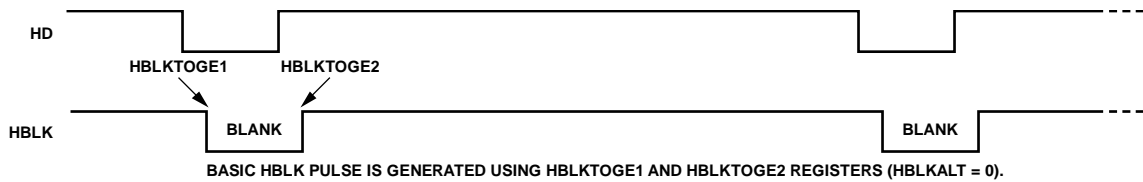

Figure 25. Typical Horizontal Blanking Pulse Placement (HBLKMODE = 0)

06955-025

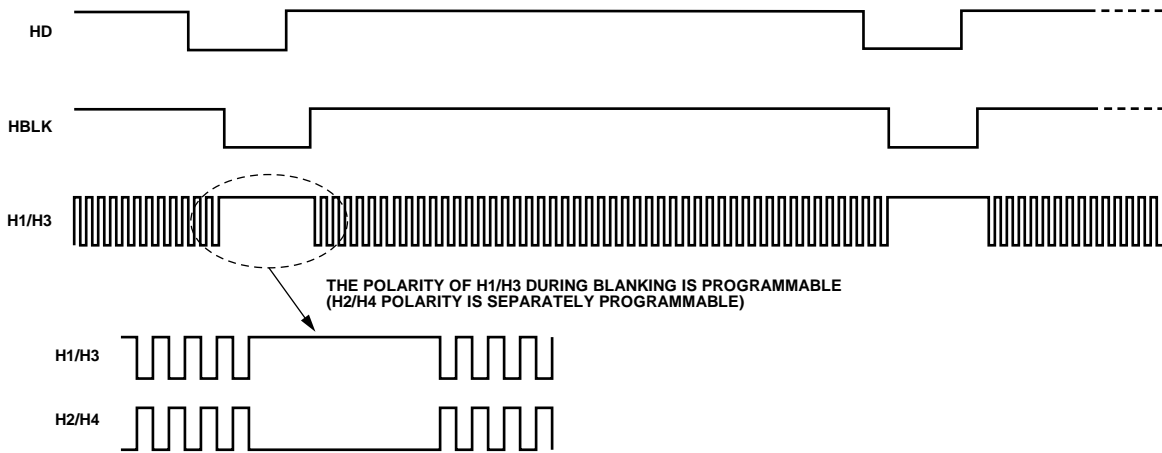

Figure 26. HBLK Masking Control

06955-026

Individual HBLK Patterns

The HBLK programmable timing shown in Figure 25 is similar to CLPOB and PBLK; however, there is no start polarity control. Only the toggle positions designate the start and the stop positions of the blanking period. Additionally, as shown in Figure 26, there is a polarity control, HBLKMASK, for H1/H3 and H2/H4 that designates the polarity of the horizontal clock signals during the blanking period. Setting HBLKMASK_H1 low sets H1 = H3 = low and HBLKMASK_H2 high sets H2 = H4 = high during the blanking period. As with the CLPOB and PBLK signals, HBLK registers are available in each H-pattern group, allowing unique blanking signals to be used with different vertical timing sequences.

The AD9974 supports three modes of HBLK operation. HBLK Mode 0 supports basic operation and provides some support for special HBLK patterns. HBLK Mode 1 supports pixel mixing HBLK operation. HBLK Mode 2 supports advanced HBLK operation. The following sections describe each mode. Register parameters are detailed in Table 12.

HBLK Mode 0 Operation

There are six toggle positions available for HBLK. Normally, only two of the toggle positions are used to generate the standard HBLK interval. However, the additional toggle positions can be used to generate special HBLK patterns, as shown in Figure 27. The pattern in this example uses all six toggle positions to generate two extra groups of pulses during the HBLK interval. By changing the toggle positions, different patterns are created.

Separate toggle positions are available for even and odd lines. If alternation is not needed, load the same values into the registers for even (HBLKTOGE) and odd (HBLKTOGO) lines.

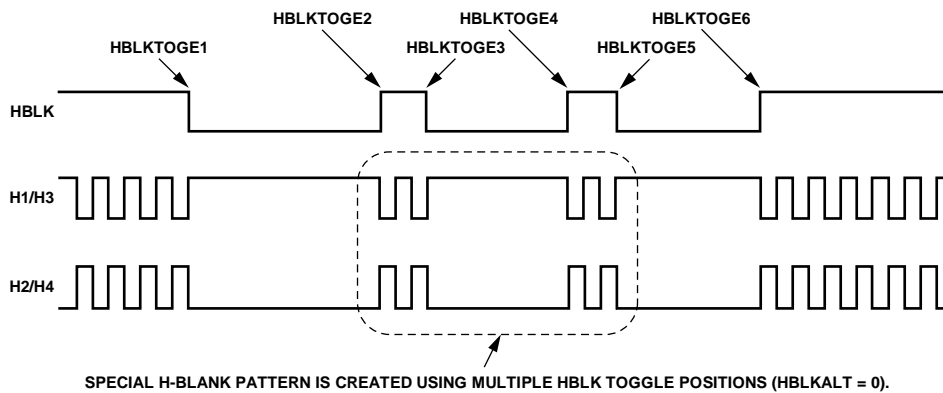

Figure 27. Generating Special HBLK Patterns

Table 12. HBLK Pattern Registers

Register	Length (Bits)	Range	Description
HBLK_MODE	2	0 to 2 HBLK modes	Enables different HBLK toggle position operations. 0 = normal mode. Six toggle positions available for even and odd lines. If even/odd alternation is not needed, set toggles for even/odd the same. 1 = pixel mixing mode. In addition to six toggle positions, the HBLKSTART, HBLKEND, HBLKLEN, and HBLKREP registers can be used to generate HBLK patterns. If even/odd alternation is not needed, set toggles for even/odd the same. 2 = advanced HBLK mode. Divides HBLK interval into six different repeat areas. Uses HBLKSTARTA/B/C and RA*H*REPA/B/C registers. 3 = test mode only. Do not access.
HBLKSTART	13	0 to 8191 pixel location	Start location for HBLK in HBLK Mode 1 and HBLK Mode 2.
HBLKEND	13	0 to 8191 pixel location	End location for HBLK in HBLK Mode 1 and HBLK Mode 2.
HBLKLEN	13	0 to 8191 pixels	HBLK length in HBLK Mode 1 and HBLK Mode 2.
HBLKREP	13	0 to 8191 repetitions	Number of HBLK repetitions in HBLK Mode 1 and HBLK Mode 2.
HBLKMASK_H1	1	High/low	Masking polarity for H1 and H3 during HBLK.
HBLKMASK_H2	1	High/low	Masking polarity for H2 and H4 during HBLK.

Register	Length (Bits)	Range	Description
HBLKTOGO1	13	0 to 8191 pixel location	First HBLK toggle position for odd lines in HBLK Mode 0 and HBLK Mode 1.
HBLKTOGO2	13	0 to 8191 pixel location	Second HBLK toggle position for odd lines in HBLK Mode 0 and HBLK Mode 1.
HBLKTOGO3	13	0 to 8191 pixel location	Third HBLK toggle position for odd lines in HBLK Mode 0 and HBLK Mode 1.
HBLKTOGO4	13	0 to 8191 pixel location	Fourth HBLK toggle position for odd lines in HBLK Mode 0 and HBLK Mode 1.
HBLKTOGO5	13	0 to 8191 pixel location	Fifth HBLK toggle position for odd lines in HBLK Mode 0 and HBLK Mode 1.
HBLKTOGO6	13	0 to 8191 pixel location	Sixth HBLK toggle position for odd lines in HBLK Mode 0 and HBLK Mode 1.
HBLKTOGE1	13	0 to 8191 pixel location	First HBLK toggle position for even lines in HBLK Mode 0 and HBLK Mode 1.
HBLKTOGE2	13	0 to 8191 pixel location	Second HBLK toggle position for even lines in HBLK Mode 0 and HBLK Mode 1.
HBLKTOGE3	13	0 to 8191 pixel location	Third HBLK toggle position for even lines in HBLK Mode 0 and HBLK Mode 1.
HBLKTOGE4	13	0 to 8191 pixel location	Fourth HBLK toggle position for even lines in HBLK Mode 0 and HBLK Mode 1.
HBLKTOGE5	13	0 to 8191 pixel location	Fifth HBLK toggle position for even lines in HBLK Mode 0 and HBLK Mode 1.
HBLKTOGE6	13	0 to 8191 pixel location	Sixth HBLK toggle position for even lines in HBLK Mode 0 and HBLK Mode 1.
RA0H1REPA/B/C	12	0 to 15 HCLK pulses for each A, B, and C	HBLK Repeat Area 0. Number of H1 repetitions for HBLKSTARTA/B/C in HBLK Mode 2 for even lines; odd lines are defined using HBLKALT_PAT. [3:0] RA0H1REPA. Number of H1 pulses following HBLKSTARTA. [7:4] RA0H1REPB. Number of H1 pulses following HBLKSTARTB. [11:8] RA0H1REPC. Number of H1 pulses following HBLKSTARTC.
RA1H1REPA/B/C	12	0 to 15 HCLK pulses	HBLK Repeat Area 1. Number of H1 repetitions for HBLKSTARTA/B/C.
RA2H1REPA/B/C	12	0 to 15 HCLK pulses	HBLK Repeat Area 2. Number of H1 repetitions for HBLKSTARTA/B/C.
RA3H1REPA/B/C	12	0 to 15 HCLK pulses	HBLK Repeat Area 3. Number of H1 repetitions for HBLKSTARTA/B/C.
RA4H1REPA/B/C	12	0 to 15 HCLK pulses	HBLK Repeat Area 4. Number of H1 repetitions for HBLKSTARTA/B/C.
RA5H1REPA/B/C	12	0 to 15 HCLK pulses	HBLK Repeat Area 5. Number of H1 repetitions for HBLKSTARTA/B/C.
RA0H2REPA/B/C	12	0 to 15 HCLK pulses for each A, B, and C	HBLK Repeat Area 0. Number of H2 repetitions for HBLKSTARTA/B/C in HBLK Mode 2 for even lines; odd lines are defined using HBLKALT_PAT. [3:0] RA0H2REPA. Number of H2 pulses following HBLKSTARTA. [7:4] RA0H2REPB. Number of H2 pulses following HBLKSTARTB. [11:8] RA0H2REPC. Number of H2 pulses following HBLKSTARTC.
RA1H2REPA/B/C	12	0 to 15 HCLK pulses	HBLK Repeat Area 1. Number of H2 repetitions for HBLKSTARTA/B/C.
RA2H2REPA/B/C	12	0 to 15 HCLK pulses	HBLK Repeat Area 2. Number of H2 repetitions for HBLKSTARTA/B/C.
RA3H2REPA/B/C	12	0 to 15 HCLK pulses	HBLK Repeat Area 3. Number of H2 repetitions for HBLKSTARTA/B/C.
RA4H2REPA/B/C	12	0 to 15 HCLK pulses	HBLK Repeat Area 4. Number of H2 repetitions for HBLKSTARTA/B/C.
RA5H2REPA/B/C	12	0 to 15 HCLK pulses	HBLK Repeat Area 5. Number of H2 repetitions for HBLKSTARTA/B/C.
HBLKSTARTA	13	0 to 8191 pixel location	HBLK Repeat Area Start Position A for HBLK Mode 2.
HBLKSTARTB	13	0 to 8191 pixel location	HBLK Repeat Area Start Position B for HBLK Mode 2.
HBLKSTARTC	13	0 to 8191 pixel location	HBLK Repeat Area Start Position C for HBLK Mode 2.
HBLKALT_PAT1	3	0 to 5 even repeat area	HBLK Mode 2, Odd Field Repeat Area 0 pattern, selected from even field. Repeat areas previously defined.
HBLKALT_PAT2	3	0 to 5 even repeat area	HBLK Mode 2, Odd Field Repeat Area 1 pattern.
HBLKALT_PAT3	3	0 to 5 even repeat area	HBLK Mode 2, Odd Field Repeat Area 2 pattern.
HBLKALT_PAT4	3	0 to 5 even repeat area	HBLK Mode 2, Odd Field Repeat Area 3 pattern.
HBLKALT_PAT5	3	0 to 5 even repeat area	HBLK Mode 2, Odd Field Repeat Area 4 pattern.
HBLKALT_PAT6	3	0 to 5 even repeat area	HBLK Mode 2, Odd Field Repeat Area 5 pattern.

HBLK Mode 1 Operation

Enable multiple repeats of the HBLK signal by setting HBLK_MODE to 1. In this mode, the HBLK pattern can be generated using a different set of registers: HBLKSTART, HBLKEND, HBLKLEN, and HBLKREP, along with the six toggle positions (see Figure 28).

Separate toggle positions are available for even and odd lines. If alternation is not needed, load the same values into the registers for even (HBLKTOGE) and odd (HBLKTOGO) lines.

Generating HBLK Line Alternation

HBLK Mode 0 and HBLK Mode 1 provide the ability to alternate different HBLK toggle positions on even and odd lines. Separate toggle positions are available for even and odd lines. If even/odd line alternation is not required, load the same values into the registers for even (HBLKTOGE) and odd (HBLKTOGO) lines.

Table 13. HCLK Width Register

Register	Length (Bits)	Description
HCLK_WIDTH	4	Controls H1 to H4 width during HBLK as a fraction of pixel rate. 0 = same frequency as pixel rate. 1 = 1/2 pixel frequency, that is, doubles the HCLK pulse width. 2 = 1/4 pixel frequency. 3 = 1/6 pixel frequency. 4 = 1/8 pixel frequency. 5 = 1/10 pixel frequency. ... 15 = 1/30 pixel frequency.

Increasing H-Clock Width During HBLK

HBLK Mode 0 and HBLK Mode 1 allow the H1 to H4 pulse width to be increased during the HBLK interval. As shown in Figure 29, the H-clock frequency can be reduced by a factor of 1/2, 1/4, 1/6, 1/8, 1/10, 1/12, and so on, up to 1/30. To enable this feature, the HCLK_WIDTH register (Address 0x34[7:4]) is set to a value between 1 and 15. When this register is set to 0, the wide HCLK feature is disabled. The reduced frequency occurs only for H1 to H4 pulses that are located within the HBLK area.

The HCLK_WIDTH register is generally used in conjunction with special HBLK patterns to generate vertical and horizontal mixing in the CCD.

Note that the wide HCLK feature is available only in HBLK Mode 0 and HBLK Mode 1, not in HBLK Mode 2.

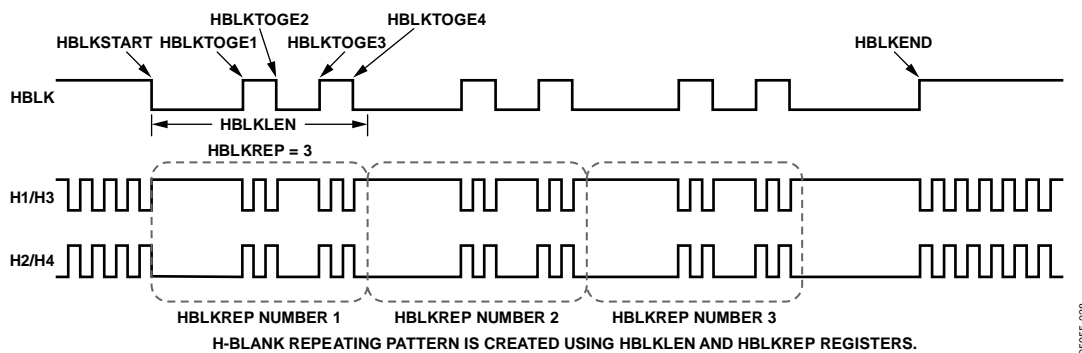
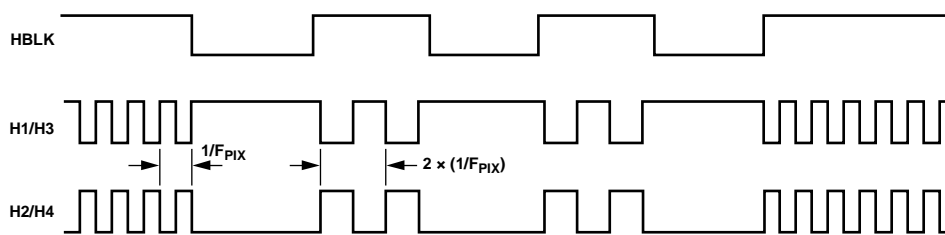

Figure 28. HBLK Repeating Pattern Using HBLKMODE = 1



H-CLOCK FREQUENCY CAN BE REDUCED DURING HBLK BY 1/2 (AS SHOWN), 1/4, 1/6, 1/8, 1/10, 1/12, AND SO ON, UP TO 1/30 USING HBLKWIDTH REGISTER.

Figure 29. Generating Wide H-Clock Pulses During HBLK Interval

HBLK Mode 2 Operation

HBLK Mode 2 allows more advanced HBLK pattern operation. If unevenly spaced HCLK pulses in multiple areas are needed, HBLK Mode 2 can be used. Using a separate set of registers, HBLK Mode 2 can divide the HBLK region into up to six repeat areas (see Table 12). As shown in Figure 31, each repeat area shares a common group of toggle positions, HBLKSTARTA, HBLKSTARTB, and HBLKSTARTC. However, the number of toggles following each start position can be unique in each repeat area by using the RAH1REP and RAH2REP registers. As shown in Figure 30, setting the RAH1REPA/RAH1REPB/RAH1REPC or RAH2REPA/RAH2REPB/RAH2REPC registers to 0 masks HCLK groups from appearing in a particular repeat area. Figure 31 shows only two repeat areas being used, although six are available. It is possible to program a separate number of repeat area repetitions for H1 and H2, but generally the same value is used for both H1 and H2.

Figure 31 shows the following example:

RA0H1REPA/RA0H1REPB/RA0H1REPC =
 RA0H2REPA/RA0H2REPB/RA0H2REPC =
 RA1H1REPA/RA1H1REPB/RA1H1REPC =
 RA1H2REPA/RA1H2REPB/RA1H2REPC = 2.

Furthermore, HBLK Mode 2 allows a different HBLK pattern on even and odd lines. The HBLKSTARTA, HBLKSTARTB, and HBLKSTARTC registers, as well as the RAH1REPA/RAH1REPB/RAH1REPC and RAH2REPA/RAH2REPB/RAH2REPC registers, define operation for the even lines. For separate control of the odd lines, the HBLKALT_PAT registers specify up to six repeat areas on the odd lines by reordering the repeat areas used for the even lines. New patterns are not available, but the order of the previously defined repeat areas on the even lines can be changed for the odd lines to accommodate advanced CCD operation.

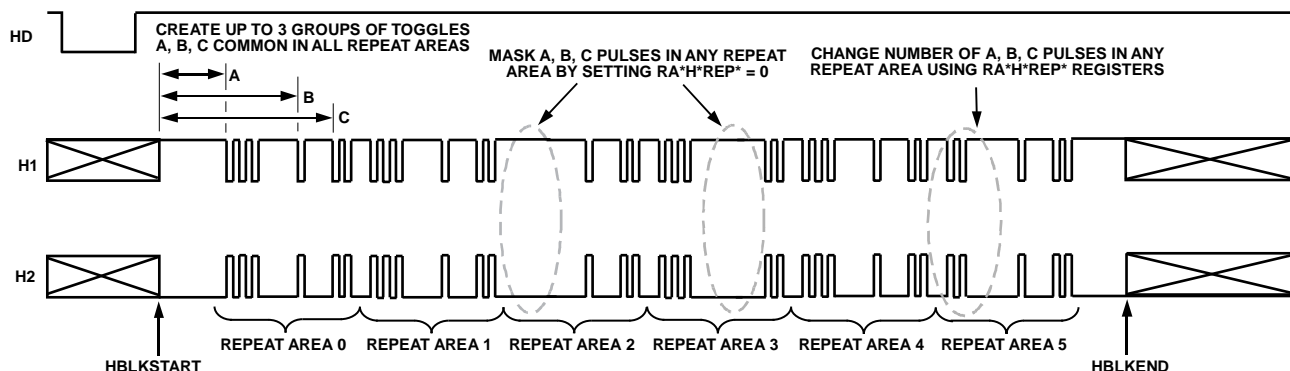

Figure 30. HBLK Mode 2 Operation

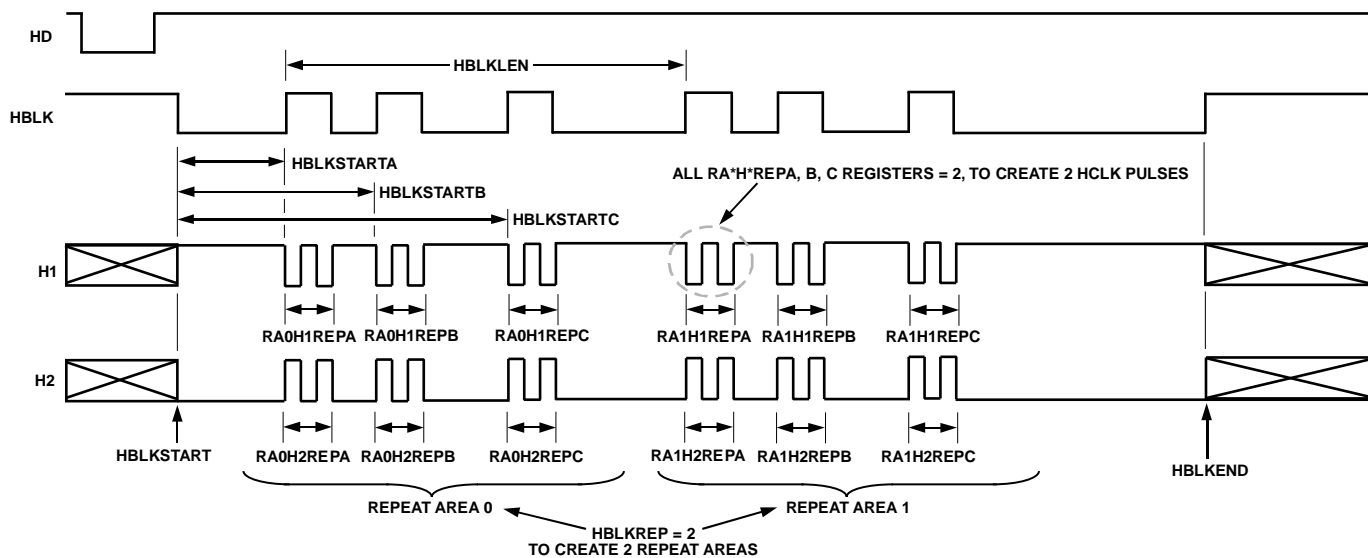

Figure 31. HBLK Mode 2 Registers

HBLK, PBLK, and CLPOB Toggle Positions

The AD9974 uses an internal horizontal pixel counter to position the HBLK, PBLK, and CLPOB toggle positions. The horizontal counter does not reset to 0 until 12 CLI periods after the falling edge of HD. This 12-cycle pipeline delay must be considered when determining the register toggle positions. For example, if CLPOB_TOG1 is 100 and the pipeline delay is not considered, the final toggle position is applied at 112. To obtain the correct toggle positions, the toggle position registers must be set to the desired toggle position minus 12.

For example, if the desired toggle position is 100, CLPOB_TOG should be set to 88 (that is, $100 - 12$). Figure 49 shows the 12-cycle pipeline delay referenced to the falling edge of HD.

Caution

Toggle positions cannot be programmed during the 12-cycle delay from the HD falling edge until the H-counter has reset. See Figure 33 for an example of this restriction.

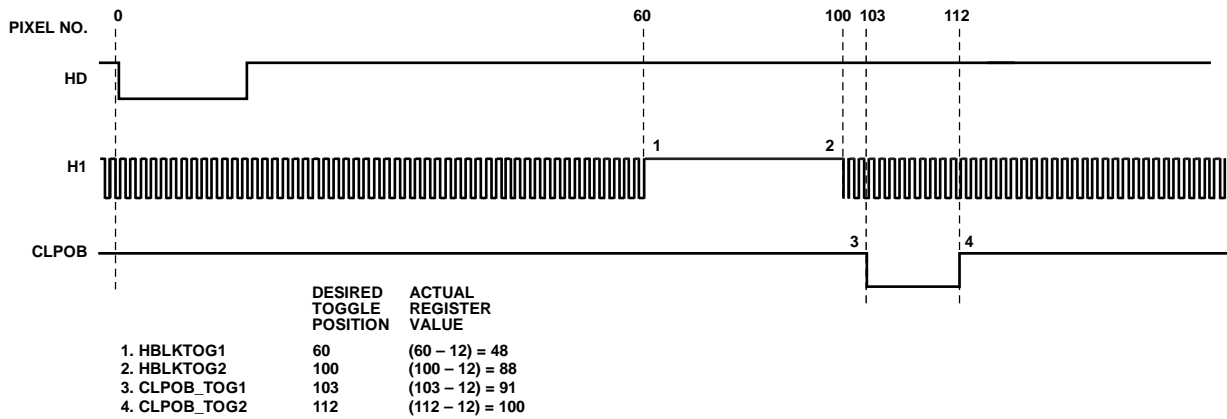

Figure 32. Example of Register Setting to Obtain Desired Toggle Positions

05955-032

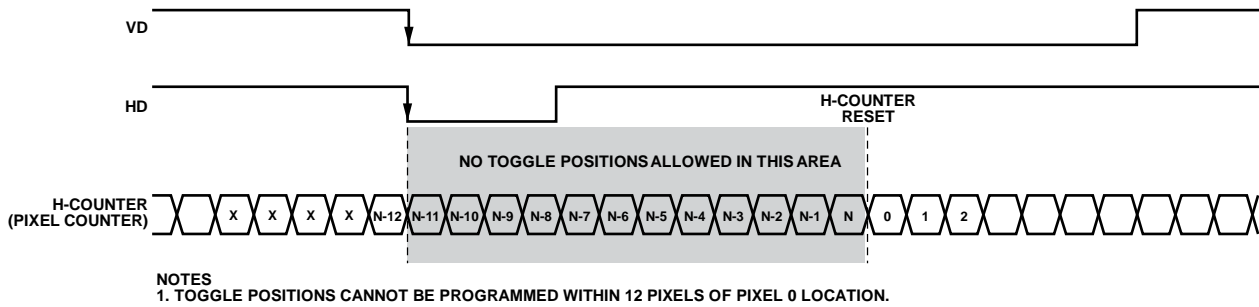

Figure 33. Restriction for Toggle Position Placement

05955-033

COMPLETE FIELD—COMBINING H-PATTERNS

After the H-patterns are created, they combine to create different readout fields. A field consists of up to nine different regions determined by the SCP registers. Within each region, a different H-pattern group can be selected up to a maximum of 32 groups. Registers to control the H-patterns are located in the field registers. Table 31 describes the field registers.

H-Pattern Selection

The H-patterns are stored in the HPAT memory, as described in Table 20. The user decides how many H-pattern groups are required, up to a maximum of 32, and then uses the HPAT_SEL registers to select which H-pattern group is output in each region of the field. Figure 34 shows how to use the HPAT_SEL and SCP registers. The SCP registers create the line boundaries for each region.

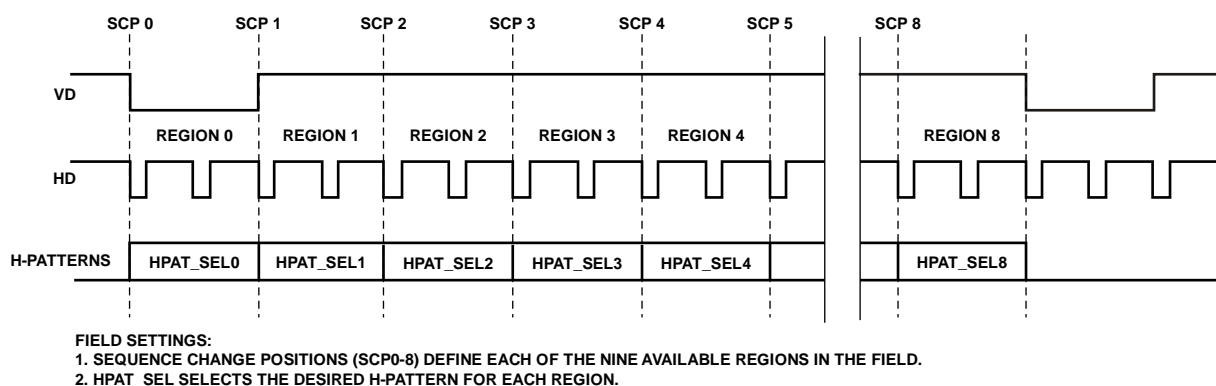

Figure 34. Complete Field Divided into Regions

00955-034

Table 14. Field Registers

Register	Length (Bits)	Range	Description
SCP _x	13	0 to 8191 line number	Sequence change position for each region. Selects an individual line.
HPAT_SEL _x	5	0 to 31 H-patterns	Selected H-pattern for each region of the field.
CLPOB_POL	9	High/low	CLPOB start polarity settings for each region of the field.
CLPOB_PAT	9	0 to 9 patterns	CLPOB pattern selector for each region of the field.
CLPOBMASKSTART _x , CLPOBMASKEND _x	13	Number of lines	CLPOB mask positions for up to three masking configurations.
PBLK_POL	9	High/low	PBLK start polarity settings for each region of the field.
PBLK_PAT	9	0 to 9 patterns	PBLK pattern selector for each region of the field.
PBLKMASKSTART _x , PBLKMASKEND _x	13	Number of lines	PBLK mask positions for up to three masking configurations.

AD9974

MODE REGISTERS

The mode registers contain registers to select the final field timing of the AD9974. Typically, all of the field and H-pattern group information is programmed into the AD9974 at startup. During operation, the mode registers allow the user to select any combination of field timing to meet the current requirements of the system. The advantage of using the mode registers in conjunction with preprogrammed timing is that they greatly reduce the system programming requirements during camera operation. Only a few register writes are required when the camera operating mode is changed, rather than having to write in all of the vertical timing information with each camera mode change.

A basic still camera application can require five fields of horizontal timing: one for draft mode operation, one for autofocusing, and three for still image readout. With the AD9974, all of the register timing information for the five fields is loaded at startup. Then, during camera operation, the mode registers select which field timing to activate, depending on how the camera is being used.

The AD9974 supports up to seven field sequences selected from up to 31 preprogrammed field groups using the FIELD_SEL registers. When FIELDNUM is greater than 1, the AD9974 starts with Field 1 and increments to each Field *n* at the start of each VD.

Figure 35 provides examples of mode configuration settings. This example assumes to have four field groups, Field Group 0 to Field Group 3, stored in memory.

Table 15. Mode Registers

Register	Length (Bits)	Range	Description
HPATNUM	5	0 to 31 H-pattern groups	Total number of H-pattern groups, starting at Address 0x800.
FIELDNUM	3	0 to 7 fields	Total number of applied fields. Set to 1 for single-field operation.
FIELD_SEL1	5	0 to 31 field groups	Selected first field.
FIELD_SEL2	5	0 to 31 field groups	Selected second field.
FIELD_SEL3	5	0 to 31 field groups	Selected third field.
FIELD_SEL4	5	0 to 31 field groups	Selected fourth field.
FIELD_SEL5	5	0 to 31 field groups	Selected fifth field.
FIELD_SEL6	5	0 to 31 field groups	Selected sixth field.
FIELD_SEL7	5	0 to 31 field groups	Selected seventh field.

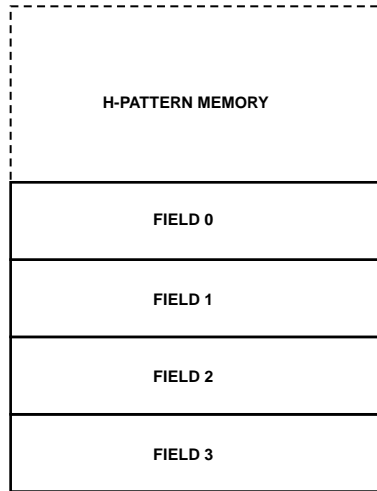

EXAMPLE 1:
 TOTAL FIELDS = 3, FIRST FIELD = FIELD 0, SECOND FIELD = FIELD 1, THIRD FIELD = FIELD 2

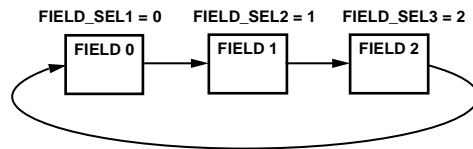

EXAMPLE 2:
 TOTAL FIELDS = 1, FIRST FIELD = FIELD 3

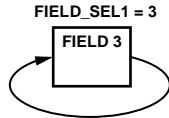

EXAMPLE 3:
 TOTAL FIELDS = 4, FIRST FIELD = FIELD 5, SECOND FIELD = FIELD 1, THIRD FIELD = FIELD 4, FOURTH FIELD = FIELD 2

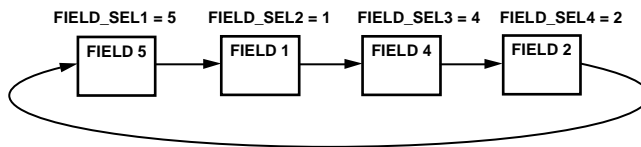

Figure 35. Example of Mode Configurations

069955-035

HORIZONTAL TIMING SEQUENCE EXAMPLE

Figure 36 shows an example of a CCD layout. The horizontal register contains 28 dummy pixels that occur on each line clocked from the CCD. In the vertical direction, there are 10 optical black (OB) lines at the front of the readout and two at the back of the readout. The horizontal direction has four OB pixels in the front and 48 in the back.

Figure 37 shows the basic sequence layout to use during the effective pixel readout. The 48 OB pixels at the end of each line are used for the CLPOB signals. PBLK is optional and is often used to blank the digital outputs during the HBLK time. HBLK is used during the vertical shift interval.

Because PBLK is used to isolate the CDS input (see the Analog Front End Description and Operation section), do not use the PBLK signal during CLPOB operation. The change in the offset behavior that occurs during PBLK impacts the accuracy of the CLPOB circuitry.

The HBLK, CLPOB, and PBLK parameters are programmed in the V-sequence registers. More elaborate clamping schemes, such as adding a separate sequence to clamp all the shielded OB lines, can be used. This requires configuring a separate V-sequence for clocking out the OB lines.

The CLPOBMASK registers are also useful for disabling the CLPOB on a few lines without affecting the setup of the clamping sequences. It is important to use CLPOB only during valid OB pixels. During other portions on the frame timing, such as vertical blanking or SG line timing, the CCD does not output valid OB pixels. Any CLPOB pulse that occurs during this time causes errors in clamping operation and, therefore, changes in the black level of the image.

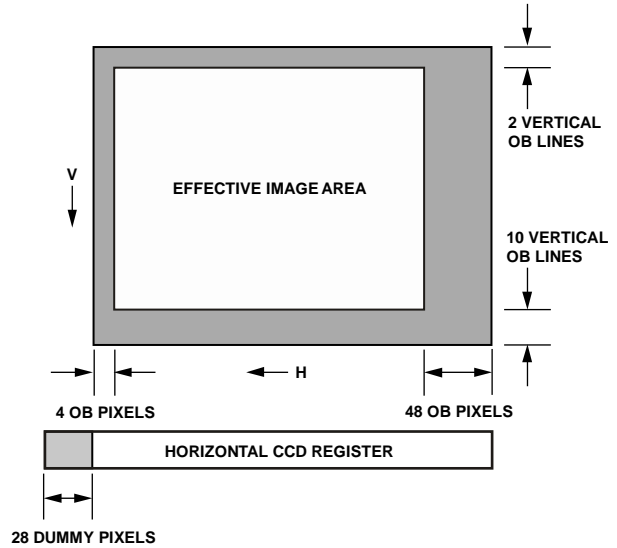
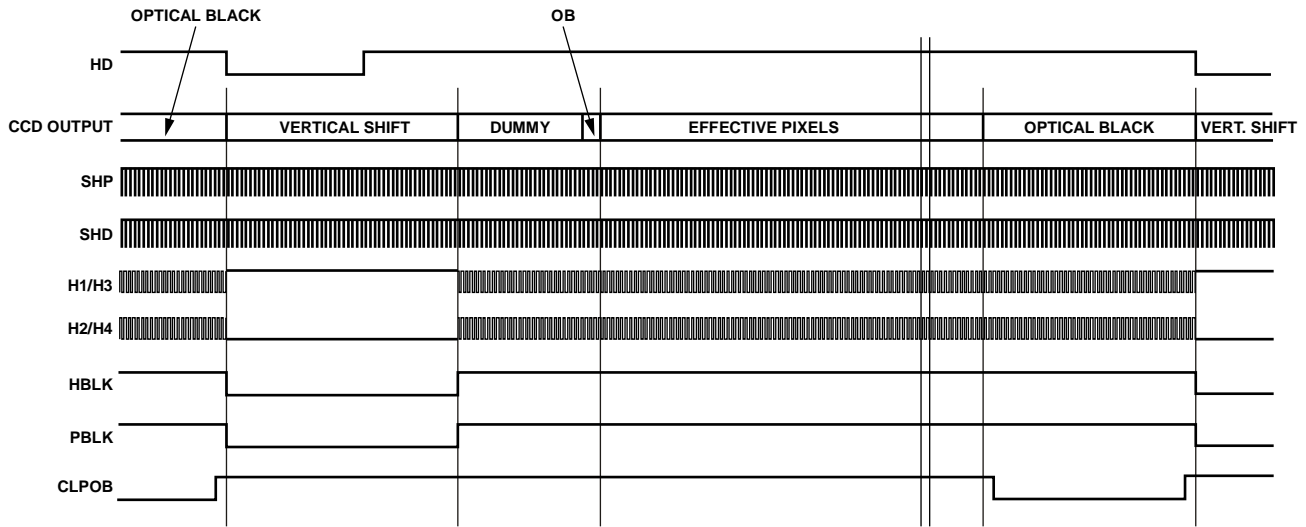

Figure 36. Example CCD Configuration

05955-036



NOTES
1. PBLK ACTIVE (LOW) SHOULD NOT BE USED DURING CLPOB ACTIVE (LOW).

Figure 37. Horizontal Sequence Example

05955-037

ANALOG FRONT END DESCRIPTION AND OPERATION

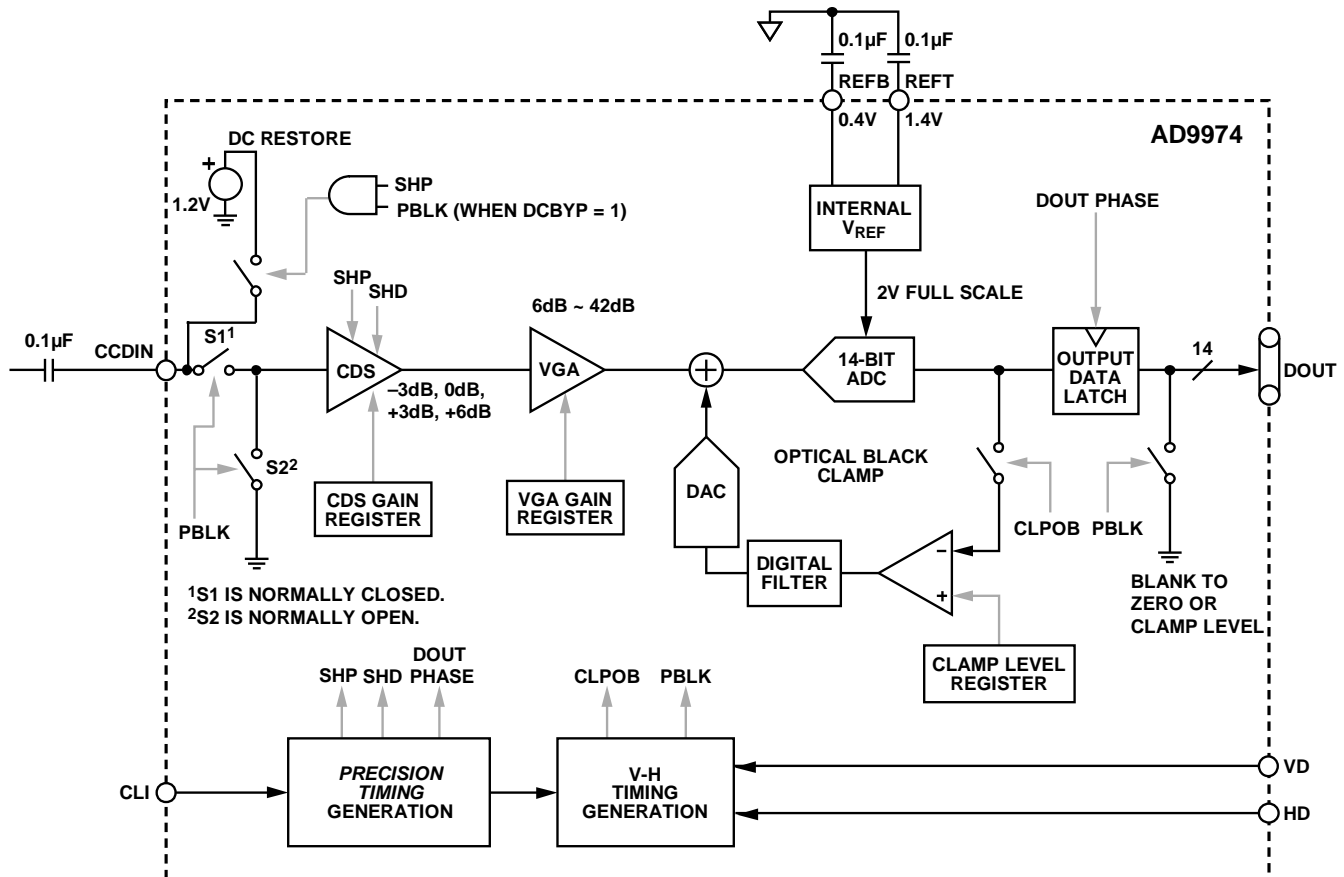

Figure 38. Channel A and Channel B Analog Front End Functional Block Diagram

The AD9974 signal processing chain is shown in Figure 38. Each processing step is essential for achieving a high quality image from the raw CCD pixel data.

DC Restore

To reduce the large dc offset of the CCD output signal, a dc restore circuit is used with an external 0.1 μF series coupling capacitor. This restores the dc level of the CCD signal to approximately 1.2 V, making it compatible with the 1.8 V core supply voltage of the AD9974. The dc restore switch is active during the SHP sample pulse time.

The dc restore circuit can be disabled when the optional PBLK signal is used to isolate large-signal swings from the CCD input (see the Analog Preblanking section). Bit 6 of Address 0x00 controls whether the dc restore is active during the PBLK interval.

Analog Preblanking

During certain CCD blanking or substrate clocking intervals, the CCD input signal to the AD9974 may increase in amplitude beyond the recommended input range. The PBLK signal can be used to isolate the CDS input from large-signal swings. As shown in Figure 38, when PBLK is active (low), the CDS input is isolated from the CCDIN pin (S1 open) and is internally shorted to ground (S2 closed).

During the PBLK active time, the ADC outputs can be programmed to output all 0s or the programmed clamp level.

Note that because the CDS input is shorted during PBLK, the CLPOB pulse should not be used during the same active time as the PBLK pulse.

Correlated Double Sampler (CDS)

The CDS circuit samples each CCD pixel twice to extract the video information and to reject low frequency noise. The timing shown in Figure 21 illustrates how the two internally generated CDS clocks, SHP and SHD, are used to sample the reference level and data level of the CCD signal, respectively. The placement of the SHP and SHD sampling edges is determined by the setting of the SHPLOC and SHDLOC register located at Address 0x36. Placement of these two clock signals is critical for achieving the best performance from the CCD. The CDS gain is variable in four steps by using the AFE Register Address 0x04: -3 dB, 0 dB (default), +3 dB, and +6 dB. Improved noise performance results from using the +3 dB and +6 dB settings, but the input range is reduced (see Table 5).

AD9974

Input Configurations

The CDS circuit samples each CCD pixel twice to extract the video information and reject low frequency noise (see Figure 39). There are three possible configurations for the CDS: inverting CDS mode, noninverting CDS mode, and SHA mode. The CDSMODE register (Address 0x00[9:8]) selects which configuration is used.

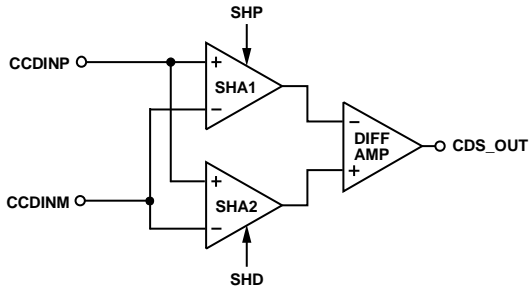
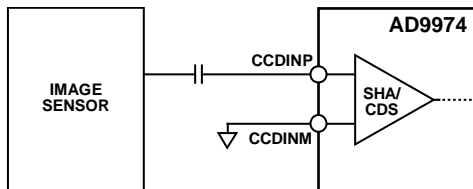

Figure 39. CDS Block Diagram (Conceptual)

Inverting CDS Mode

For this configuration, the signal from the CCD is applied to the positive input of the (CCDINP) CDS system with the minus side (CCDINM) grounded (see Figure 40). The CDSMODE register setting for this configuration is 0x00. Traditional CCD applications use this configuration with the reset level established below the AVDD supply level by the AD9974 dc restore circuit, at approximately 1.5 V. The maximum saturation level is 1.0 V below the reset level, as shown in Figure 41 and Table 16. A maximum saturation voltage of 1.4 V is also possible when using the minimum CDS gain setting.



NOTES
1. COUPLING CAPACITOR IS NOT REQUIRED FOR CERTAIN BLACK LEVEL REFERENCE VOLTAGES.

Figure 40. Single Input CDS Configuration

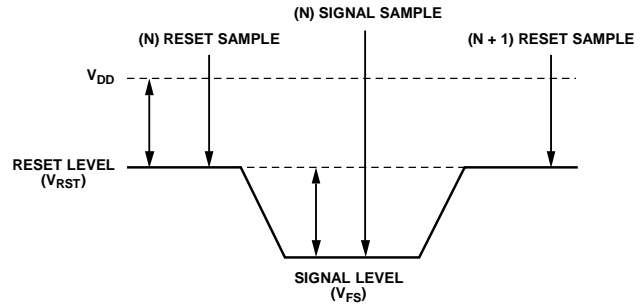

Figure 41. Traditional Inverting CDS Signal

Table 16. Inverting Voltage Levels

Signal Level	Symbol	Min (mV)	Typ (mV)	Max (mV)
Saturation	V_{FS}		1000	1400
Reset	V_{RST}	$V_{DD} - 500$	$V_{DD} - 300$	V_{DD}
Supply Voltage	V_{DD}	1600	1800	2000

Noninverting Input

If the noninverting input is desired, the reset (or black) level signal is established at a voltage above ground potential. Saturation (or white) level is approximately 1 V. Samples are taken at each signal level. See Figure 42 and Table 17.

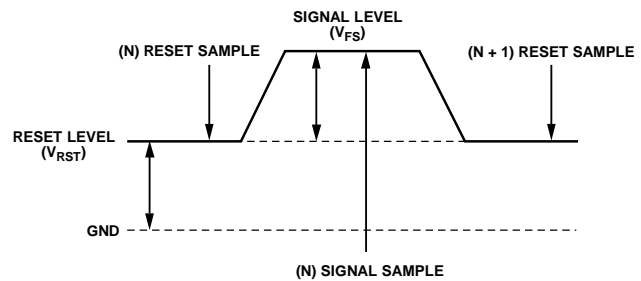

Figure 42. Noninverting CDS Signal

Table 17. Noninverting Voltage Levels

Signal Level	Symbol	Min (mV)	Typ (mV)	Max (mV)
Saturation	V_{FS}		1000	1400
Reset	V_{RST}	0	250	500

SHA Mode—Differential Input Configuration

This configuration uses a differential input sample/hold amplifier (SHA) (see Figure 43).

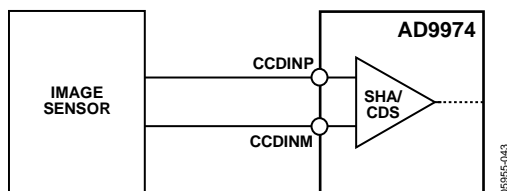

Figure 43. SHA Mode—Differential Input Configuration

In this configuration, a signal is applied to the CCDINP input and, simultaneously, an inverse signal is applied to the CCDINM input. Sampling occurs on both signals at the same time. This creates the differential output for amplification and the ADC (see Figure 44 and Table 18).

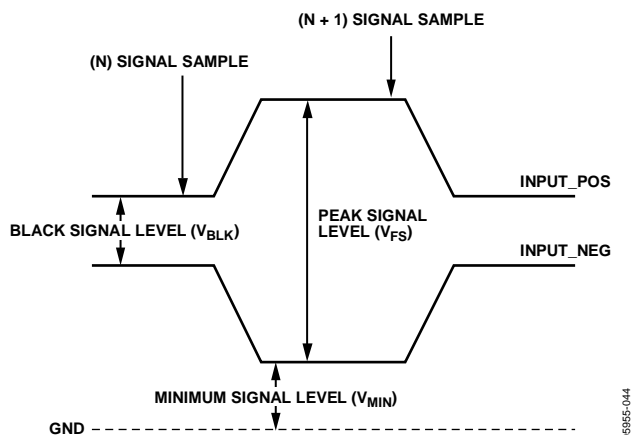

Figure 44. SHA Mode—Differential Input Signal

Table 18. SHA Mode—Differential Voltage Levels

Signal Level	Symbol	Min (mV)	Typ (mV)	Max (mV)
Black	V_{BLK}		0	
Saturation	V_{FS}	1000	$V_{DD} - 300$	1400
Minimum	V_{MIN}	0	1800	

SHA Mode—DC-Coupled, Single-Ended Input

The SHA mode can also be used in a single-ended fashion, with the signal from the image sensor applied to the CDS/SHA using a single input, CCDINP. This is similar to the differential configuration, except in this case, the CCDINM line is held at a constant dc voltage, establishing a reference level that matches the image sensor reference voltage (see Figure 45).

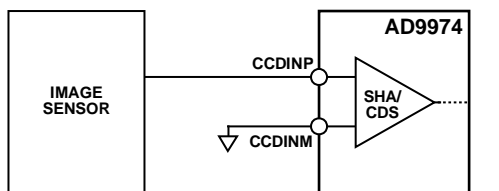

NOTES
1. DC VOLTAGE ABOVE GROUND MAYBE USED TO MATCH THE SENSOR REFERENCE LEVEL.

Figure 45. SHA Mode—Single-Ended Input Configuration, DC-Coupled

Referring to Figure 46 and Table 19, the CCDINM signal is a constant dc voltage set at a level above ground potential. The sensor signal is applied to the other input, and samples are taken at the signal minimum and at a point of signal maximum. The resulting differential signal is the difference between the signal and the reference voltage.

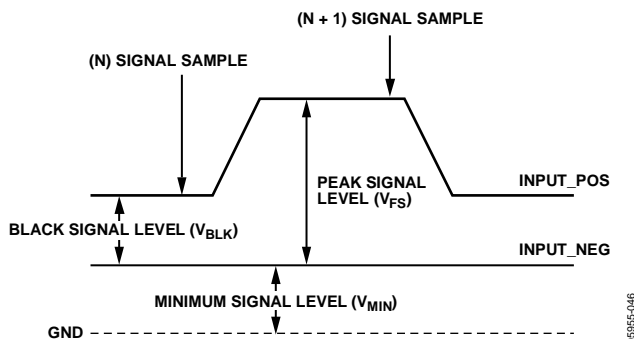

Figure 46. SHA Mode—Single-Ended Input Signal (DC-Coupled)

Table 19. SHA Mode—Single-Ended Input Voltages

Signal Level	Symbol	Min (mV)	Typ (mV)	Max (mV)
Black	V_{BLK}		0	
Saturation	V_{FS}		1000	1400
Minimum	V_{MIN}	0		

CDS Timing Control

The timing shown in Figure 21 illustrates how the two internally generated CDS clocks, SHP and SHD, are used to sample the reference level and data level of the CCD signal, respectively. The placement of the SHP and SHD sampling edges is determined by the setting of the SHPLOC and SHDLOC register located at Address 0x36. Placement of these two clock signals is critical in achieving the best performance from the CCD.

SHA Timing Control

When SHA mode is selected, only the SHPLOC setting is used to sample the input signal, but the SHDLOC signal should still be programmed to an edge setting of SHPLOC + 32.

Variable Gain Amplifier

The VGA stage provides a gain range of approximately 6 dB to 42 dB, programmable with 10-bit resolution through the serial digital interface. A gain of 6 dB is needed to match a 1 V input signal with the ADC full-scale range of 2 V. When compared to 1 V full-scale systems, the equivalent gain range is 0 dB to 36 dB.

The VGA gain curve follows a linear-in-dB characteristic. The exact VGA gain is calculated for any gain register value by

$$\text{Gain (dB)} = (0.0359 \times \text{Code}) + 5.1 \text{ dB}$$

where *Code* is the range of 0 to 1023.

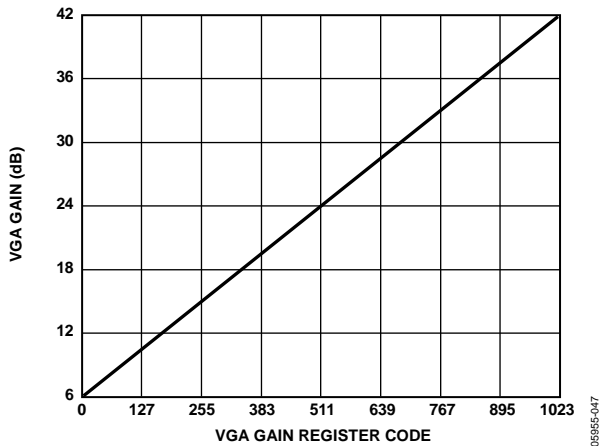

Figure 47. VGA Gain Curve

ADC

The AD9974 uses a high performance ADC architecture optimized for high speed and low power. Differential nonlinearity (DNL) performance is typically better than 0.5 LSB. The ADC uses a 2 V input range. See Figure 5, Figure 6, and Figure 7 for typical noise performance and linearity plots for the AD9974.

Optical Black Clamp

The optical black clamp loop is used to remove residual offsets in the signal chain and track low frequency variations in the CCD black level. During the optical black (shielded) pixel interval on each line, the ADC output is compared with a fixed black level reference, selected by the user in the clamp level register. The value can be programmed between 0 LSB and 1023 LSB in 1023 steps.

The resulting error signal is filtered to reduce noise, and the correction value is applied to the ADC input through a DAC. Normally, the optical black clamp loop is turned on once per horizontal line, but this loop can be updated more slowly to suit a particular application. If external digital clamping is used during postprocessing, the AD9974 optical black clamping can be disabled using Bit 3 in AFE Register Address 0x00. When the loop is disabled, the clamp level register can still be used to provide fixed offset adjustment.

Note that if the CLPOB loop is disabled, higher VGA gain settings reduce the dynamic range because the uncorrected offset in the signal path is gained up.

The CLPOB pulse should be aligned with the optical black pixels of the CCD. It is recommended that the CLPOB pulse duration be at least 20 pixels wide. Shorter pulse widths can be used, but the ability of the loop to track low frequency variations in the black level is reduced. See the Horizontal Clamping and Blanking section for more timing information.

Digital Data Outputs

The AD9974 digital output data is latched using the DOUTPHASE register value, as shown in Figure 38. Output data timing is shown in Figure 22. The switching of the data outputs can couple noise back into the analog signal path. To minimize any switching noise while using default SHPLOC and SHDLOC, it is recommended that the DOUTPHASEP register be set to a value between 36 and 47. Other settings can produce good results, but experimentation is necessary.

APPLICATIONS INFORMATION

RECOMMENDED POWER-UP SEQUENCE

When the AD9974 is powered up, the following sequence is recommended (see Figure 48 for each step).

1. Turn on the power supplies for the AD9974 and apply CLI clock. There is no required sequence for turning on each supply.
2. Although the AD9974 contains an on-chip power-on reset, a software reset of the internal registers is recommended. Write 1 to the SW_RST register (Address 0x10) to reset all the internal registers to their default values. This bit is self-clearing and automatically resets to 0.
3. Write to the desired registers to configure high speed timing and horizontal timing. Note that all TESTMODE registers must be written as described in the Complete Register Listing section.
4. To place the part into normal power operation, write 0 to the STANDBY and REFBUF_PWRDN registers (Address 0x00).

5. The *Precision Timing* core must be reset by writing 1 to the TGCORE_RST register (Address 0x14). This starts the internal timing core operation.
6. Write 1 to the OUT_CONTROL register (Address 0x11).

The next VD/HD falling edge allows register updates to occur, including OUT_CONTROL, which enables all clock outputs.

Additional Restrictions

When operating, note the following restrictions:

- The HD falling edge should be located in the same CLI clock cycle as the VD falling edge or after the VD falling edge. The HD falling edge should not be located between one and five cycles prior to the VD falling edge.
- If possible, perform all start-up serial writes with VD and HD disabled. This prevents unknown behavior caused by partial updating of registers before all information is loaded.

The internal horizontal counter is reset 12 CLI cycles after the falling edge of HD. See Figure 49 for details on how the internal counter is reset.

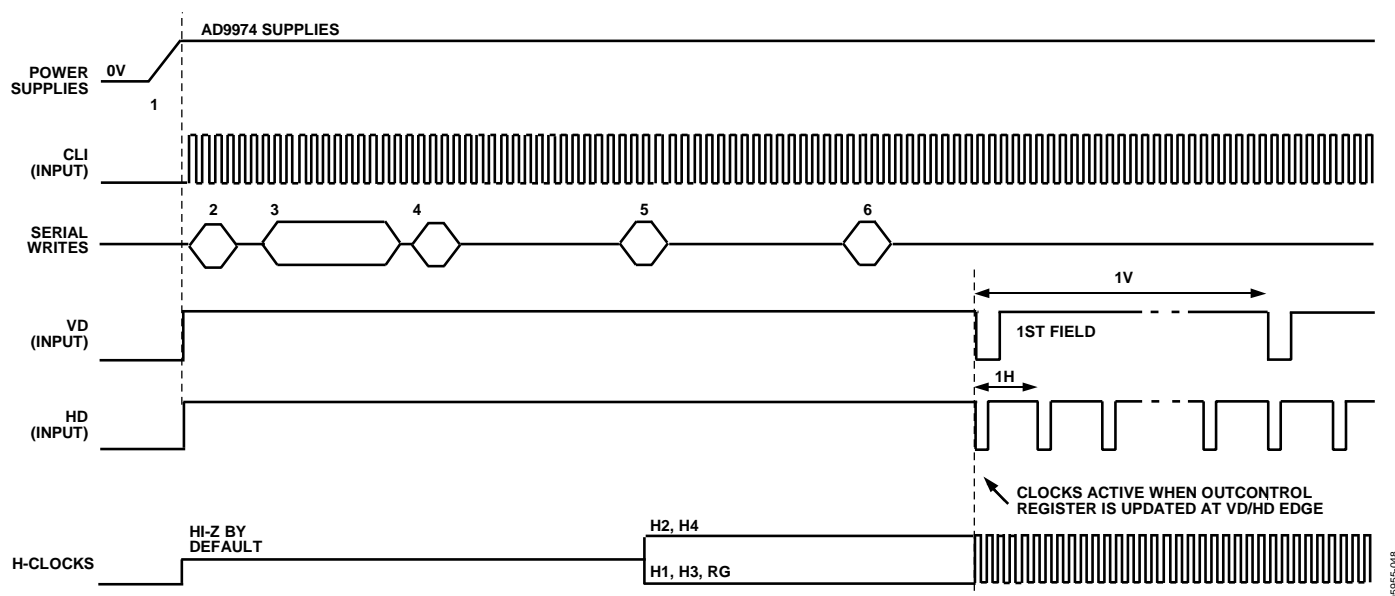

Figure 48. Recommended Power-Up Sequence

05985-048

Example Register Settings for Power-Up

The following settings can be used for basic operation. A single CLPOB pulse is used with only H-pattern and one field. Additional HPATS and FIELDS can be added, as needed, along with different CLPOB toggle positions.

```
010 0000001 //software reset
028 0000001 //total number of H-Pattern groups = 1
800 0064000 //HPAT0 HBLKTOG01, TOG02 settings
801 3fffffff //unused HBLK odd toggles set to zero or max value
802 3fffffff //unused HBLK odd toggles set to zero or max value
803 0064000 //HPAT0 HBLKTOGE1, TOGE2 settings
804 3fffffff //unused HBLK Even toggles set to zero or max value
805 3fffffff //unused HBLK Even toggles set to zero or max value
806 0000000 //HBLK StartA, B are not used
807 0000000 //HBLK StartC is not used
808 0000000 //HBLK alternation patterns are not used
809 0000000 //HBLKLEN, HBLKREP not used, HBLK masking pol = 0
80a 0000000 //HBLKSTART, end not used
80b 0000000 //test, set to zero
80c 00dc05a //CLPOB pat 0 toggles
80d 3fffffff //CLPOB pat 1 toggles not used, set to max
80e 3fffffff //PBLK pat 0 toggles not used, set to max
80f 3fffffff //PBLK pat 1 toggles not used, set to max
810 1000000 //FIELD0 SCP0, SCP1
811 1000800 //SCP2, SCP3 set same as SCP1
812 1000800 //SCP4, SCP5 set same as SCP1
813 1000800 //SCP6, SCP7 set same as SCP1
814 0000800 //SCP8 set same as SCP1
815 0000000 //select HPAT0 for all regions
816 0000000 //select HPAT0 for all regions
817 0000000 //test, set to zero
818 0000001 //CLK start polarity = HIGH
819 1000800 //CLPOB masking set to highest SCP value (no mask)
81a 1000800 //CLPOB masking set to highest SCP value (no mask)
81b 1000800 //CLPOB masking set to highest SCP value (no mask)
81c 0000001 //PBLK start polarity = HIGH
81d 1000800 //PBLK masking set to highest SCP value (no mask)
81e 0000000 //PBLK masking set to highest SCP value (no mask)
81f 0000000 //PBLK masking set to highest SCP value (no mask)
02a 0000001 //total number of fields = 1
02b 0000000 //field select = FIELD0
02c 0000000 //field select = FIELD0
000 0000008 //AFE settings
014 0000001 //reset TGCORE
011 0000001 //enable outputs
```

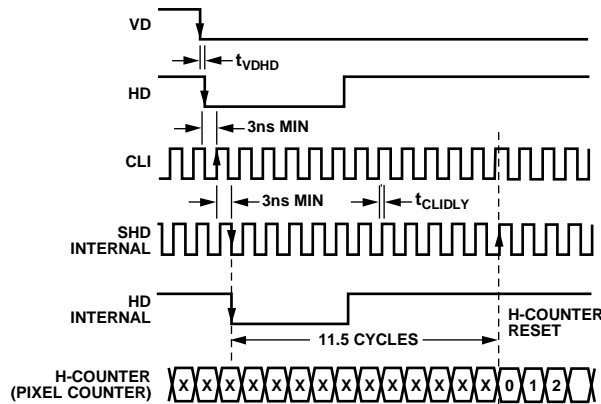

- NOTES**
- EXTERNAL HD FALLING EDGE IS LATCHED BY CLI RISING EDGE, THEN LATCHED AGAIN BY SHD INTERNAL FALLING EDGE.
 - INTERNAL H-COUNTER IS ALWAYS RESET 11.5 CLOCK CYCLES AFTER THE INTERNAL HD FALLING EDGE.
 - DEPENDENT ON THE VALUE OF SHDLOC, H-COUNTER RESET CAN OCCUR 12 OR 13 CLI CLOCK EDGES AFTER THE EXTERNAL HD FALLING EDGE.
 - SHPLOC = 0 IS SHOWN IN THE ABOVE EXAMPLE. IN THIS CASE, THE H-COUNTER RESET OCCURS 12 CLI RISING EDGES AFTER HD FALLING EDGE.
 - HD FALLING EDGE SHOULD OCCUR COINCIDENT WITH VD FALLING EDGE (WITHIN SAME CLI CYCLE) OR AFTER VD FALLING EDGE. HD FALLING EDGE SHOULD NOT OCCUR WITHIN 1 AND 5 CLI CYCLES IMMEDIATELY BEFORE VD FALLING EDGE.

Figure 49. Horizontal Counter Pipeline Delay

05985-049

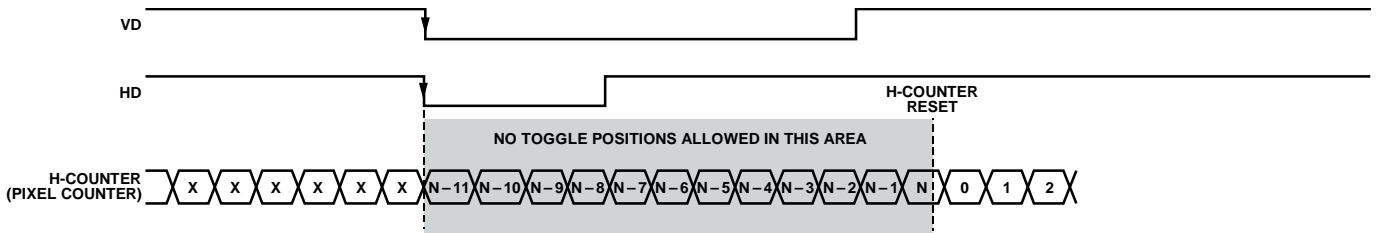

- NOTES**
- TOGGLE POSITIONS CANNOT BE PROGRAMMED WITHIN 12 PIXELS OF PIXEL 0 LOCATION.

Figure 50. No-Toggle Positions

05985-050

Additional Restrictions

When operating, note the following restrictions:

- The HD falling edge should be located in the same CLI clock cycle as the VD falling edge or later than the VD falling edge. The HD falling edge should not be located within 1 cycle prior to the VD falling edge.

- If possible, perform all start-up serial writes with VD and HD disabled. This prevents unknown behavior caused by partial updating of registers before all information is loaded.

The internal horizontal counter is reset 12 CLI cycles after the falling edge of HD. See Figure 49 for details on how the internal counter is reset.

STANDBY MODE OPERATION

The AD9974 contains two standby modes to optimize the overall power dissipation in a particular application. Bit 1 and Bit 0 of Address 0x00 control the power-down state of the device.

STANDBY[1:0] = 00 = normal operation (full power)

STANDBY[1:0] = 01 = reference standby mode

STANDBY[1:0] = 10 or 11 = total shutdown mode
(lowest power)

Table 20 summarizes the operation of each power-down mode. The OUT_CONTROL register takes priority over the reference standby mode in determining the digital output states, but total shutdown mode takes priority over OUT_CONTROL. Total shutdown mode has the lowest power consumption.

Table 20. Standby Mode Operation

I/O Block	Total Shutdown (Default) ^{1, 2}	OUT_CONTROL = Low ²	Reference Standby
AFE	Off	No change	Only REFT, REFB on
Timing Core	Off	No change	On
H1	High-Z	Low	Low (4.3 mA)
H2	High-Z	High	High (4.3 mA)
H3	High-Z	Low	Low (4.3 mA)
H4	High-Z	High	High (4.3 mA)
HL	High-Z	Low	Low (4.3 mA)
RG	High-Z	Low	Low (4.3 mA)
DOUT	Low ³	Low	Low

¹ To exit total shutdown, write 00 to STANDBY (Address 0x00, Bits[1:0]), then reset the timing core after 100 μ s to guarantee proper settling.

² Total shutdown mode takes priority over OUT_CONTROL for determining the output polarities.

³ The status of the DOUT pins is unknown at power-up. Low status is guaranteed in total shutdown mode after the power-up sequence is completed.

When returning from total shutdown mode to normal operation, the timing core must be reset at least 100 μ s after the STANDBY register is written to.

There is an additional register to disable the internal voltage reference buffer (Address 0x00[2]) independently. By default the buffer is disabled, but it must be enabled for normal operation.

CLI FREQUENCY CHANGE

If the input clock, CLI, is interrupted or changes to a different frequency, the timing core must be reset for proper operation. After the CLI clock has settled to the new frequency, or the previous frequency has resumed, write 0 and then 1 to the TGCORE_RST register (Address 0x14). This guarantees proper timing core operation.

CIRCUIT CONFIGURATION

The AD9974 recommended circuit configuration is shown in Figure 51. Achieving good image quality from the AD9974 requires careful attention to PCB layout. All signals should be routed to maintain low noise performance. The CCD_A and CCD_B output signals should be directly routed to Pin A1 and Pin A7, respectively, through a 0.1 μ F capacitor. The master clock, CLI_X, should be carefully routed to Pin A3 and Pin A9 to minimize interference with the CCDIN_X, REFT_X, and REFB_X signals.

The digital outputs and clock inputs should be connected to the digital ASIC away from the analog and CCD clock signals. Placing series resistors close to the digital output pins may help reduce digital code transition noise. If the digital outputs must drive a load larger than 20 pF, buffering is recommended to minimize additional noise. If the digital ASIC can accept gray code, the outputs of the AD9974 can be selected to output data in gray code format using Register 0x01[2]. Compared with binary coding, gray coding helps reduce potential digital transition noise.

The H1_X to H4_X and RG_X traces should have low inductance to avoid excessive distortion of the signals. Heavier traces are recommended because of the large transient current demand on H1_X to H4_X from the capacitive load of the CCD. If possible, physically locating the AD9974 closer to the CCD reduces the inductance on these lines. As always, the routing path should be as direct as possible from the AD9974 to the CCD.

The CLI_X and CCDIN_X PCB traces should be carefully matched in length and impedance to achieve optimal channel-to-channel matching performance.

3 V System Compatibility

The AD9974 typical circuit connections for a 3 V system are shown in Figure 51. This application uses an external 3.3 V supply connected to the IOVDD input of the AD0074, which also serves as the LDO input. The LDO generates a 1.8 V output for the AD9974 core supply voltages, AVDD and DVDD. The LDOOUT pin can then be connected directly to the AVDD and DVDD pins. In this configuration, the LDOEN pin is tied high to enable the LDO.

Alternatively, a separate 1.8 V regulated supply voltage may be used to power the AVDD and DVDD pins. In this case, the LDOOUT pin needs to be left floating, and the LDOEN pin needs to be grounded. A typical circuit configuration for a 1.8 V system is shown in Figure 51.

GROUNDING AND DECOUPLING RECOMMENDATIONS

As shown in Figure 51, a single ground plane is recommended for the AD9974. This ground plane needs to be as continuous as possible, particularly around the P-type, AI-type, and A-type pins to ensure that all analog decoupling capacitors provide the lowest possible impedance path between the power and bypass pins and their respective ground pins. All high frequency decoupling capacitors need to be located as close as possible to the package pins.

All the supply pins must be decoupled to ground with good quality, high frequency chip capacitors. There also needs to be a 4.7 μ F or larger bypass capacitor for each main supply, that is, AVDD, RGVDD, HVDD, and DRVDD, although this is not necessary for each individual pin. In most applications, it is easier to share the supply for RGVDD and HVDD, which can be done as long as the individual supply pins are separately bypassed. A separate 3 V supply can be used for DRVDD, but this supply pin still needs to be decoupled to the same ground plane as the rest of the chip. A separate ground for DRVSS is not recommended.

The reference bypass pins (REFT, REFB) must be decoupled to ground as close as possible to their respective pins. The bridge capacitor between REFT and REFB is recommended for pixel rates greater than 40 MHz. The analog input capacitor (CCDINM, CCDINP) also needs to be located close to the pin.

The GND connections should be tied to the lowest impedance ground plane on the PCB. Performance does not degrade if several of these GND connections are left unconnected for routing purposes.

AD9974

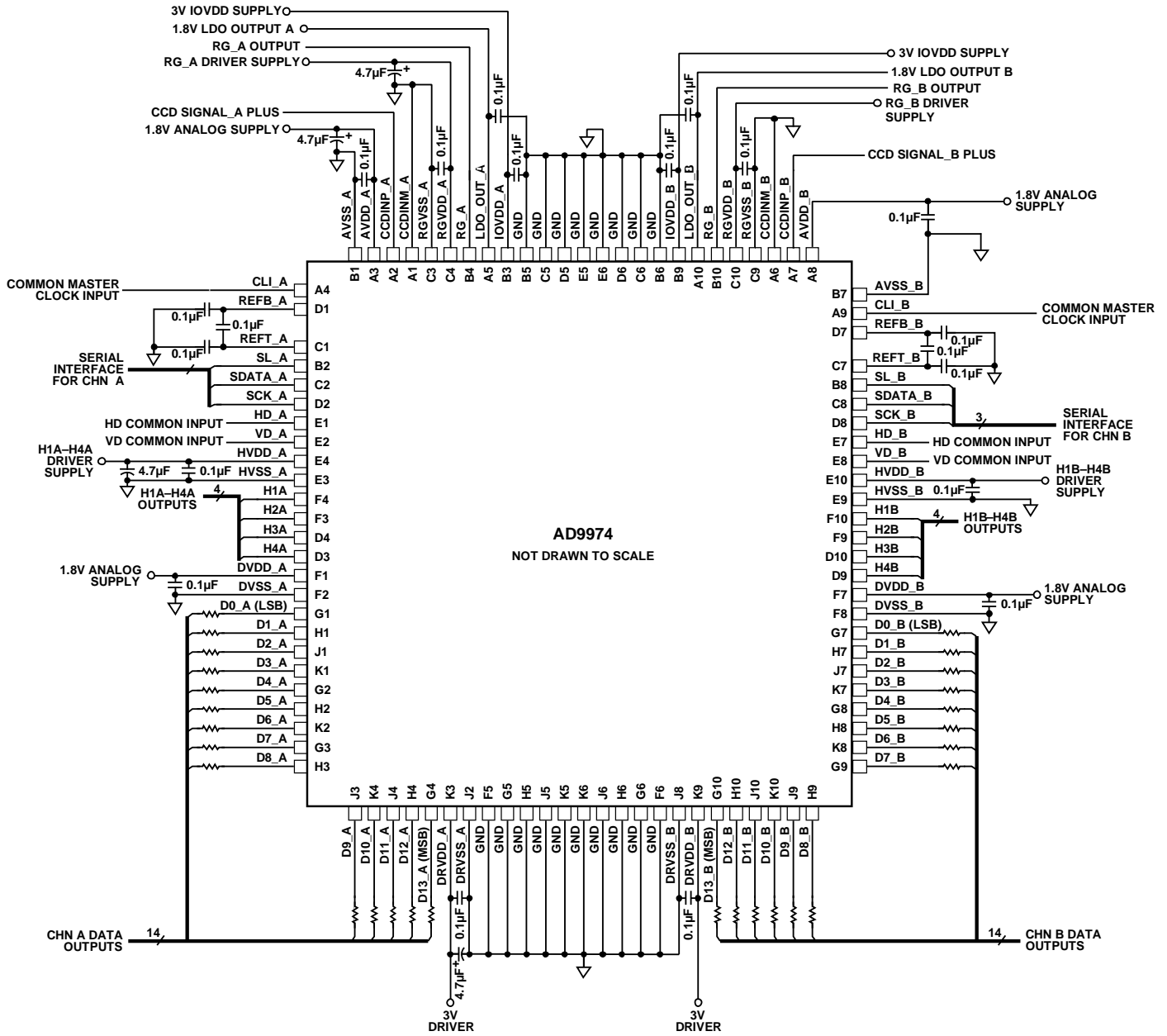

Figure 51. Recommended Circuit Configuration

3-WIRE SERIAL INTERFACE TIMING

All of the internal registers of the AD9974 are accessed through a 3-wire serial interface. Each register consists of a 12-bit address and a 28-bit data-word. Both the 12-bit address and 28-bit data-word are written starting with the LSB. To write to each register, a 40-bit operation is required, as shown in Figure 52. Although many registers are fewer than 28 bits wide, all 28 bits must be written for each register. For example, if the register is only 20 bits wide, the upper eight bits are don't cares and must be filled with 0s during the serial write operation. If fewer than 28 data bits are written, the register is not updated with new data.

Figure 53 shows a more efficient way to write to the registers, using the AD9974 address auto-increment capability. Using this method, the lowest desired address is written first, followed by multiple 28-bit data-words. Each new 28-bit data-word is automatically written to the next highest register address. By eliminating the need to write each 12-bit address, faster register loading is achieved. Continuous write operations can be used, starting with any register location.

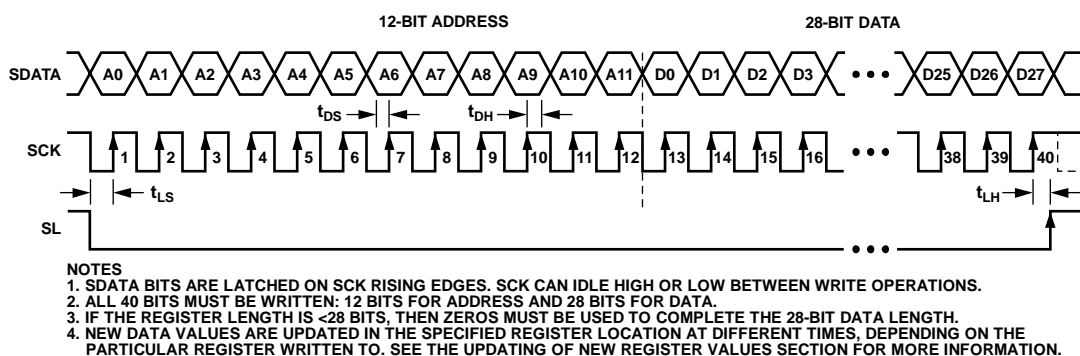

Figure 52. Serial Write Operation

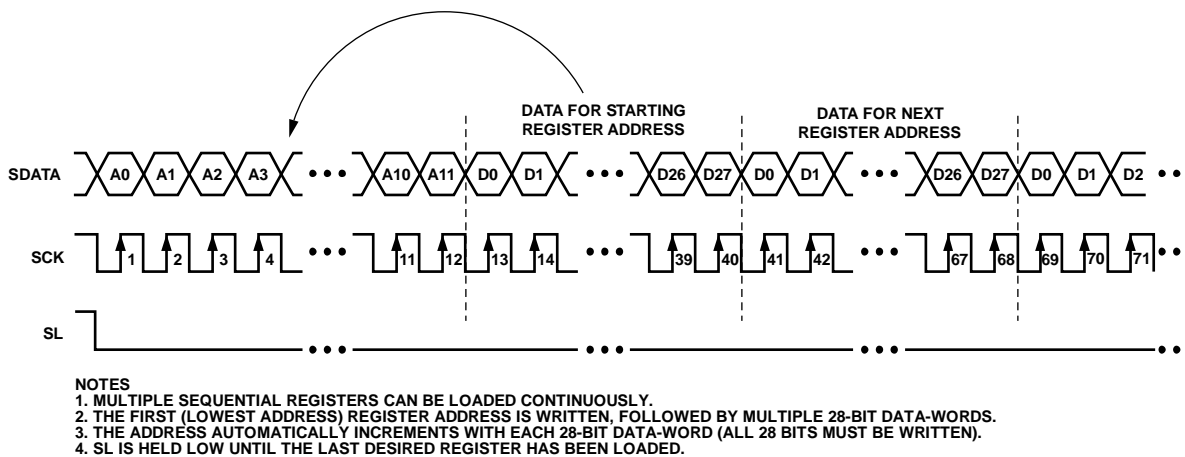

Figure 53. Continuous Serial Write Operation

LAYOUT OF INTERNAL REGISTERS

The AD9974 address space is divided into two register areas, as shown in Figure 54. In the first area, Address 0x00 to Address 0x72 contain the registers for the AFE, miscellaneous functions, VD/HD parameters, I/O control, mode control, timing core, and update control functions. The second area of the address space, beginning at Address 0x800, consists of the registers for the H-pattern groups and fields. This is a configurable set of register spaces; the user can decide how many H-patterns and fields are used in a particular design. The AD9974 supports the use of up to 32 H-patterns.

Register 0x28 specifies the total number of H-pattern groups. The starting address for the H-pattern groups is always 0x800. The starting address for the field registers is determined by the number of H-pattern groups. Each H-pattern group and field occupies 16 register addresses.

The starting address for the field registers is based on the number of H-pattern groups and is equal to 0x800 plus the number of H-pattern groups times 16.

It is important to note that the H-pattern and field registers must always occupy a continuous block of addresses.

Figure 55 shows an example when three H-pattern groups and two fields are used. The starting address for the H-pattern groups is always 0x800. Because HPATNUM is 3, the H-pattern groups occupy 48 address locations (that is, 16 registers \times 3 H-pattern groups). The starting address of the field registers for this example is 0x830 (that is, 0x800 + 48 (decimal)). Note that the decimal value must be converted to a hex number before adding it to 0x800.

The AD9974 address space contains many unused addresses. Any undefined addresses between Address 0x00 and Address 0x7FF should not be written to; otherwise, the AD9974 may operate incorrectly. Continuous register writes should be performed carefully so that undefined registers are not written to.

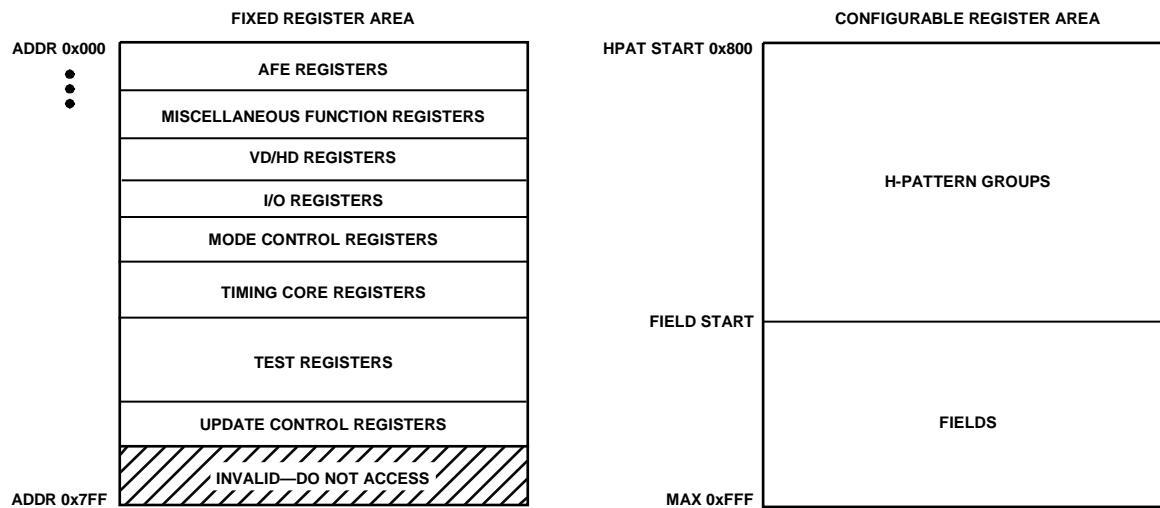

NOTES
1. THE H-PATTERN AND FIELD REGISTERS MUST ALWAYS OCCUPY A CONTINUOUS BLOCK OF ADDRESSES.

Figure 54. Layout of AD9974 Registers

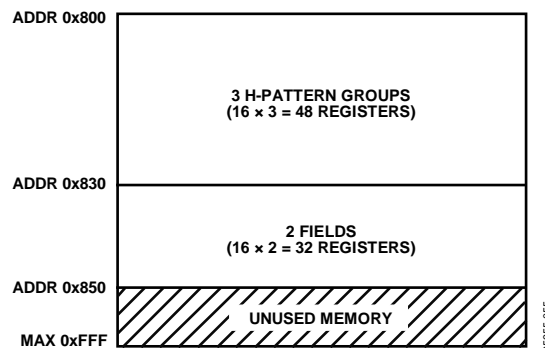

Figure 55. Example Register Configuration

UPDATING OF REGISTER VALUES

The internal registers of the AD9974 are updated at different times, depending on the particular register.

Table 21 summarizes the three types of register updates. The tables in the Complete Register Listing section also contain a column with update type to identify when each register is updated.

- **SCK Updated**—Some of the registers are updated immediately as the 28th data bit (D27) is written. These registers are used for functions that do not require gating with the next VD boundary, such as power-up and reset functions.
- **VD Updated**—Many of the registers are updated at the next VD falling edge. By updating these values at the next VD edge, the current field is not corrupted, and the new register values are applied to the next field. The VD update can be further delayed past the VD falling edge by using UPDATE Register Address 0x17. This delays the VD-updated register updates to any HD line in the field. Note that the field registers are not affected by the UPDATE register.
- **SCP Updated**—All of the H-pattern group registers are updated at the next SCP when they are used.

Table 21. Register Update Types

Update Type	Description
SCK Updated	Register is immediately updated when the 28th data bit (D27) is clocked in.
VD Updated	Register is updated at the VD falling edge. VD-updated registers can be delayed further by using the UPDATE register at Address 0x17. Field registers are not affected by the UPDATE register.
SCP Updated	Register is updated at the next SCP when the register is used.

COMPLETE REGISTER LISTING

All addresses and default values are expressed in hexadecimal. When an address contains less than 28 data bits, all remaining bits must be written as 0s. All TESTMODE registers must be set to the specified values.

Table 22. AFE Registers

Address	Data Bit Content	Default Value	Update	Name	Description
0x00	[1:0]	3	SCK	STANDBY	Standby Modes. 0 = normal operation. 1 = band gap reference in standby. 2, 3 = total power-down.
	[2]	1		REFBUF_PWRDN	Reference Buffer for REFT and REFB Power Control. 0 = REFT/REFB internally driven. 1 = REFT/REFB not driven.
	[3]	1		CLAMPENABLE	Clamp Enable Control. 0 = disable black clamp. 1 = enable black clamp.
	[5:4]	0		TESTMODE	Test Operation Only. Set to 0.
	[6]	0		PBLK_LVL	PBLK Level Control. 0 = blank to 0. 1 = blank to clamp level.
	[7]	0		DCBYP	DC Restore Circuit Control. 0 = enable dc restore circuit during PBLK. 1 = bypass dc restore circuit during PBLK.
	[9:8]	0		CDSMODE	CDS Operation. 0 = normal (inverting) CDS mode. 1 = sample and hold (SHA) mode. 2 = positive CDS mode. 3 = invalid, do not use.
[16:10] [27:17]	0	TESTMODE Unused	Test Operation Only. Set to 0. Set unused bits to 0.		
0x01	[1:0]	0	SCK	TESTMODE	Test Operation Only. Set to 0.
	[2]	0		GRAYENCODE	Gray Coding ADC Outputs. 0 = disable. 1 = enable.
	[3]	0		TESTMODE	Test Operation Only. Set to 0.
	[4]	1		TESTMODE	Test Operation Only. Set to 0.
[27:5]		Unused	Set unused bits to 0.		
0x02	[0]	0	SCK	TESTMODE	Test Operation Only. Set to 0.
	[27:1]			Unused	Set unused bits to 0.
0x03	[23:0]	FFFFFF	SCK	TESTMODE	Test Operation Only. Set to FFFFFFFF.
	[27:24]			Unused	Set unused bits to 0.
0x04	[1:0]	1	VD	CDSGAIN	CDS Gain Setting. 0 = -3 dB. 1 = 0 dB (default). 2 = +3 dB. 3 = +6 dB.
	[27:2]			Unused	Set unused bits to 0.
0x05	[9:0]	F	VD	VGAGAIN	VGA Gain. 6 dB to 42 dB (0.035 dB per step).
	[27:10]			Unused	Set unused bits to 0.
0x06	[9:0]	1EC	VD	CLAMPLEVEL	Optical Black Clamp Level. 0 LSB to 1023 LSB (1 LSB per step).
	[27:10]			Unused	Set unused registers to 0.
0x07	[27:0]	0		TESTMODE	Test Operation Only. Set to 0 if this register is accessed.
0x08	[27:0]	0		TESTMODE	Test Operation Only. Set to 0 if this register is accessed.
0x09	[27:0]	0		TESTMODE	Test Operation Only. Set to 0 if this register is accessed.
0x0A	[27:0]	0		TESTMODE	Test Operation Only. Set to 0 if this register is accessed.
0x0B	[27:0]	0		TESTMODE	Test Operation Only. Set to 0 if this register is accessed.

Address	Data Bit Content	Default Value	Update	Name	Description
0x0C	[27:0]	0	VD	TESTMODE	Test Operation Only. Set to 0 if this register is accessed.
0x0D	[0]	0	VD	CLIDIVIDE	CLI Divide. 1 = divide CLI input frequency by 2.
	[3:1] [27:4]	0		TESTMODE Unused	Test Operation Only. Set to 0. Set unused bits to 0.
0x0E	[27:0]		SCK	Unused	Set unused register to 0 if accessed.
0x0F	[27:0]		SCK	Unused	Set unused register to 0 if accessed.

Table 23. Miscellaneous Registers

Address	Data Bit Content	Default Value	Update	Name	Description
0x10	[0]	0	SCK	SW_RST	Software Reset. Bit self-clears to 0 when a reset occurs. 1 = reset Address 0x00 to Address 0xFF to default values.
	[27:1]			Unused	Set unused bits to 0.
0x11	[0]	0	VD	OUT_CONTROL	Output Control. 0 = make all outputs dc inactive. 1 = enable outputs at next VD edge.
	[27:1]			Unused	Set unused bits to 0.
0x12	[1:0] [27:2]	0	SCK	TESTMODE Unused	Test Operation Only. Set to 0. Set unused bits to 0.
0x13	[0] [27:1]	0	SCK	TESTMODE Unused	Test Operation Only. Set to 0. Set unused bits to 0.
0x14	[0] [27:1]	0	SCK	TGCORE_RST Unused	Timing Core Reset Bar. 0 = hold in reset. 1 = resume operation. Set unused bits to 0.
0x15	[0] [27:1]	0	SCK	CLI_BIAS Unused	Enable bias for CLI input (see Figure 11). 0 = disable bias (CLI input is dc-coupled). 1 = enable bias (CLI input is ac-coupled). Set unused bits to 0.
0x16	[0] [27:1]	0	SCK	TESTMODE Unused	Test Operation Only. Set to 0. Set unused bits to 0.
0x17	[12:0] [13] [27:14]	0 0	SCK	UPDATE PREVENTUP Unused	Serial Interface Update Line. Sets the line (HD) within the field to update the VD-updated registers. Disabled when PREVENTUP = 1. Prevents normal update of VD-updated registers. 0 = normal update at VD. 1 = prevent update of VD-updated registers. Set unused bits to 0.
0x18	[27:0]	0		TESTMODE	Test Operation Only. Set to 0 if this register is accessed.
0x19	[27:0]	0		TESTMODE	Test Operation Only. Set to 0 if this register is accessed.
0x1A to 0x1F	[27:0]			Unused	Set unused bits to 0.

Table 24. VD/HD Registers

Address	Data Bit Content	Default Value	Update	Name	Description
0x20	[0] [27:1]	0	SCK	TESTMODE Unused	Test Operation Only. Set to 0. Set unused bits to 0.
0x21	[0] [2:1] [27:3]	0 0	SCK	VDHDPOL TESTMODE Unused	VD/HD Active Polarity. 0 = active low. 1 = active high. Test Operation Only. Set to 0. Set unused bits to 0.
0x22	[27:0]	0		TESTMODE	Test Operation Only. Set to 0 if this register is accessed.

Table 25. I/O Control Registers

Address	Data Bit Content	Default Value	Update	Name	Description
0x23	[0]	0	SCK	TESTMODE	Test Operation Only. Set to 0.
	[1]	0		TESTMODE	Test Operation Only. Set to 0.
	[2]	0		IO_NVR	IOVDD Voltage Range for VD, HD, SCK, SDATA, and SL. 0 = 1.8 V. 1 = 3.3 V. The I/Os are 3 V tolerant, so there is no problem having higher than 1.8 V inputs at start-up, but this register should be set to 1 at initialization if using higher than 1.8 V supplies.
	[3]	0		DATA_NVR	DRVDD Voltage Range.
	[4]	0		TESTMODE	Test Operation Only. Set to 0.
	[7:5]	1		HCLKMODE	Selects HCLK output configuration (see Table 9).
	[27:8]				Unused
0x24	[27:0]	0		TESTMODE	Test Operation Only. Set to 0 if this register is accessed.
0x25	[27:0]	0		TESTMODE	Test Operation Only. Set to 0 if this register is accessed.
0x26	[27:0]	0		TESTMODE	Test Operation Only. Set to 0 if this register is accessed.
0x27	[27:0]	0		TESTMODE	Test Operation Only. Set to 0 if this register is accessed.

Table 26. Mode Registers

Address	Data Bit Content	Default Value	Update	Name	Description
0x28	[4:0]	0	VD	HPATNUM	Total Number of H-Pattern Groups.
	[27:5]			Unused	Set unused bits to 0.
0x29	[27:0]			Unused	Set unused register to 0 if accessed.
0x2A	[2:0]	0	VD	FIELDNUM	Total Number of Fields. Set to 1 for single-field operation.
	[27:3]			Unused	Set unused bits to 0.
0x2B	[4:0]	0	VD	FIELD_SEL1	Selected First Field.
	[9:5]	0	VD	FIELD_SEL2	Selected Second Field.
	[14:10]	0		FIELD_SEL3	Selected Third Field.
	[19:15]	0		FIELD_SEL4	Selected Fourth Field.
	[24:20]	0		FIELD_SEL5	Selected Fifth Field.
	[27:25]				Unused
0x2C	[4:0]	0	VD	FIELD_SEL6	Selected Sixth Field.
	[9:5]			FIELD_SEL7	Selected Seventh Field.
	[27:10]			Unused	Set unused bits to 0.
0x2D	[27:0]		SCK	Unused	Set unused register to 0 if this register is accessed.
0x2E	[27:0]		SCK	Unused	Set unused register to 0 if this register is accessed.
0x2F	[27:0]		SCK	Unused	Set unused register to 0 if this register is accessed.

Table 27. Timing Core Registers

Address	Data Bit Content	Default Value	Update	Name	Description
0x30	[5:0] [7:6] [13:8] [15:14] [16] [27:17]	0 20 0 1	SCK	H1POSLOC Unused H1NEGLOC TESTMODE H1POL Unused	H1 Rising Edge Location. Set unused bits to 0. H1 Falling Edge Location. Test Operation Only. Set to 0. H1 Polarity Control. 0 = inverse of Figure 21. 1 = no inversion. Set unused bits to 0.
0x31	[5:0] [7:6] [13:8] [15:14] [16] [27:17]	0 20 0 1	SCK	H2POSLOC Unused H2NEGLOC TESTMODE H2POL Unused	H2 Rising Edge Location. Set unused bits to 0. H2 Falling Edge Location. Test Operation Only. Set to 0. H2 Polarity Control. 0 = inverse of Figure 21. 1 = no inversion. Set unused bits to 0.
0x32	[5:0] [7:6] [13:8] [15:14] [16] [27:17]	0 20 0 1	SCK	TESTMODE Unused TESTMODE TESTMODE TESTMODE Unused	Test Operation Only. Set to 0. Set unused bits to 0. Test Operation Only. Set to 20. Test Operation Only. Set to 0. Test Operation Only. Set to 1. Set unused bits to 0.
0x33	[5:0] [7:6] [13:8] [15:14] [16] [27:17]	0 10 0 1	SCK	RGPOSLOC Unused RGNEGLOC TESTMODE RGPOL Unused	RG Rising Edge Location. Set unused bits to 0. RG Falling Edge Location. Test Operation Only. Set to 0. RG Polarity Control. 0 = inverse of Figure 21. 1 = no inversion. Set unused bits to 0.
0x34	[0] [1] [2] [3] [7:4] [27:8]	0 0 0 0 0	SCK	H1BLKRETIME H2BLKRETIME TESTMODE TESTMODE HCLK_WIDTH Unused	Retime H1 HBLK to Internal Clock. 0 = no retime. 1 = enable retime. Recommended setting is enable retime. Enabling retime adds one cycle delay to programmed HBLK positions. Retime H2 HBLK to Internal Clock. Test Operation Only. Set to 0 Test Operation Only. Set to 0 Enables wide H-clocks during HBLK interval. 0 = disable (see Table 13). Set unused bits to 0.
0x35	[2:0] [3] [6:4] [7]	1 1	SCK	H1DRV Unused H2DRV Unused	H1 Drive Strength. 0 = off. 1 = 4.3 mA. 2 = 8.6 mA. 3 = 12.9 mA. 4 = 17.2 mA. 5 = 21.5 mA. 6 = 25.8 mA. 7 = 30.1 mA. Set unused bits to 0. H2 Drive Strength. Set unused bits to 0.

AD9974

Address	Data Bit Content	Default Value	Update	Name	Description
	[10:8] [11] [14:12] [15] [18:16] [19] [22:20] [27:23]	1 1 1 0		H3DRV Unused H4DRV Unused TESTMODE Unused RGDRV Unused	H3 Drive Strength. Set unused bits to 0. H4 Drive Strength. Set unused bits to 0. Test Operation Only. Set to 0. Set unused bits to 0. RG Drive Strength. Set unused bits to 0.
0x36	[5:0] [11:6] [17:12] [27:18]	0 20 10	SCK	SHDLOC SHPLOC SHPWIDTH Unused	SHD Sampling Edge Location. SHP Sampling Edge Location. SHP Width. Controls input dc restore switch active time. Set unused bits to 0.
0x37	[5:0] [11:6] [12] [14:13] [15] [27:16]	0 20 0 2 0	SCK	DOUPHASEP DOUPHASEN DCLKMODE CLKDATA_SEL INV_DCLK Unused	DOUPHASEP Positive Edge Phase Control. DOUPHASEN Negative Edge Phase Control. Set DOUPHASEN = DOUPHASEP + 0x20. 0 = DCLK tracks DOUT phase. 1 = DCLK is CLI post-Schmitt trigger and post-divider when CLIDIVIDE = 1. Data Output Clock Selection. 0 = no delay. 1 = ~4 ns. 2 = ~8 ns. 3 = ~12 ns. 0 = no invert. 1 = invert DCLK to output. Set unused bits to 0.
0x38	[27:0]			Unused	Set unused register to 0 if this register is accessed.
0x39	[27:0]			Unused	Set unused register to 0 if this register is accessed.
0x3A	[27:0]			Unused	Set unused register to 0 if this register is accessed.
0x3B	[27:0]			Unused	Set unused register to 0 if this register is accessed.
0x3C	[27:0]			Unused	Set unused register to 0 if this register is accessed.
0x3D	[27:0]			Unused	Set unused register to 0 if this register is accessed.

Table 28. Test Registers—Do Not Access

Address	Data Bit Content	Default Value	Update	Name	Description
0x3E	[18:0] [27:19]	4B020	SCK	TESTMODE Unused	Test Operation Only. Set to 4B020. Set unused bits to 0.
0x3F	[27:0]		SCK	Unused	Set unused register to 0 if these registers are accessed.
0x40	[3:0] [9:4] [27:10]	F 0	SCK	TESTMODE TESTMODE Unused	Test Operation Only. Set to F if accessed. Test Operation Only. Set to 0. Set unused bits to 0.
0x41 to 0x4F	[27:0]		SCK	Unused	Set unused register to 0 if these registers are accessed.
0x50 to 0x5F	[27:0]		SCK	Unused	Set unused register to 0 if these registers are accessed.

Table 29. Update Control Registers

Address	Data Bit Content	Default Value	Update	Name	Description
0x60	[15:0] [27:16]	1803	SCK	AFE_UPDT_SCK Unused	Enable SCK update of AFE registers. Each bit corresponds to one address location. AFE_UPDT_SCK[0] = 1, update Address 0x00 on SL rising edge. AFE_UPDT_SCK[1] = 1, update Address 0x01 on SL rising edge. ... AFE_UPDT_SCK[15] = 1, update Address 0x0F on SL rising edge. Set unused register = 0 if accessed.
0x61	[15:0] [27:16]	E7FC	SCK	AFE_UPDT_VD Unused	Enable VD update of AFE registers. Each bit corresponds to one address location. AFE_UPDT_VD[0] = 1, update Address 0x00 on VD rising edge. AFE_UPDT_VD[1] = 1, update Address 0x01 on VD rising edge. ... AFE_UPDT_VD[15] = 1, update Address 0x0F on VD rising edge. Set unused register to 0 if accessed.
0x62	[15:0] [27:16]	F8FD	SCK	MISC_UPDT_SCK Unused	Enable SCK update of miscellaneous registers. Address 0x10 to Address 0x1F. Set unused register to 0 if accessed.
0x63	[15:0] [27:16]	0702	SCK	MISC_UPDT_VD Unused	Enable VD update of miscellaneous registers, Address 0x10 to Address 0x1F. Set unused register to 0 if accessed.
0x64	[15:0] [27:16]	FFF9	SCK	VDHD_UPDT_SCK Unused	Enable SCK update of VDHD Registers, Address 0x20 to Address 0x22. Set unused register to 0 if accessed.
0x65	[15:0] [27:16]	0006	SCK	VDHD_UPDT_VD Unused	Enable VD update of VDHD registers, Address 0x20 to Address 0x22. Set unused register to 0 if accessed.
0x66	[15:0] [27:16]	FFFF	SCK	TGCORE_UPDT_SCK Unused	Enable SCK update of timing core registers, Address 0x30 to Address 0x37. Set unused register to 0 if accessed.
0x67	[15:0] [27:16]	0000	SCK	TGCORE_UPDT_VD Unused	Enable VD update of timing core registers, Address 0x30 to Address 0x37. Set unused register to 0 if accessed.
0x68 to 0x72	[27:0]		SCK	Unused	Set unused register to 0 if accessed.

Table 30. HPAT Registers (HPAT Registers Always Start at Address 0x800)

Address	Data Bit Content	Default Value	Update	Name	Description
0x00	[12:0] [25:13] [27:26]	X X X	SCP	HBLKTOGO1 HBLKTOGO2 Unused	First HBLK Toggle Position for Odd Lines, or RA0H1REPA/B/C. Second HBLK Toggle Position for Odd Lines, or RA1H1REPA/B/C. Set unused bits to 0.
0x01	[12:0] [25:13] [27:26]	X X X	SCP	HBLKTOGO3 HBLKTOGO4 Unused	Third HBLK Toggle Position for Odd Lines, or RA2H1REPA/B/C. Fourth HBLK Toggle Position for Odd Lines, or RA3H1REPA/B/C. Set unused bits to 0.
0x02	[12:0] [25:13] [27:26]	X X X	SCP	HBLKTOGO5 HBLKTOGO6 Unused	Fifth HBLK Toggle Position for Odd Lines, or RA4H1REPA/B/C. Sixth HBLK Toggle Position for Odd Lines, or RA5H1REPA/B/C. Set unused bits to 0.
0x03	[12:0] [25:13] [27:26]	X X X	SCP	HBLKTOGE1 HBLKTOGE2 Unused	First HBLK Toggle Position for Even Lines, or RA0H2REPA/B/C. Second HBLK Toggle Position for Even Lines, or RA1H2REPA/B/C. Set unused bits to 0.
0x04	[12:0] [25:13] [27:26]	X X X	SCP	HBLKTOGE3 HBLKTOGE4 Unused	Third HBLK Toggle Position for Even Lines, or RA2H2REPA/B/C. Fourth HBLK Toggle Position for Even Lines, or RA3H2REPA/B/C. Set unused bits to 0.

AD9974

Address	Data Bit Content	Default Value	Update	Name	Description
0x05	[12:0] [25:13] [27:26]	X X X	SCP	HBLKTOGE5 HBLKTOGE6 Unused	Fifth HBLK Toggle Position for Even Lines, or RA4H2REPA/B/C. Sixth HBLK Toggle Position for Even Lines, or RA5H2REPA/B/C. Set unused bits to 0.
0x06	[12:0] [25:13] [27:26]	X X X	SCP	HBLKSTARTA HBLKSTARTB Unused	HBLK Repeat Area Start Position A. Used during HBLK Mode 2. HBLK Repeat Area Start Position B. Used during HBLK Mode 2. Set unused bits to 0.
0x07	[12:0] [27:13]	X X	SCP	HBLKSTARTC Unused	HBLK Repeat Area Start Position C. Used during HBLK Mode 2. Set unused bits to 0.
0x08	[2:0] [5:3] [8:6] [11:9] [14:12] [17:15] [19:18] [20] [27:21]	X X X X X X X X X	SCP	HBLKALT_PAT1 HBLKALT_PAT2 HBLKALT_PAT3 HBLKALT_PAT4 HBLKALT_PAT5 HBLKALT_PAT6 HBLK_MODE TESTMODE Unused	HBLK Pattern 1 Order. Used during pixel mixing mode. HBLK Pattern 2 Order. Used during pixel mixing mode. HBLK Pattern 3 Order. Used during pixel mixing mode. HBLK Pattern 4 Order. Used during pixel mixing mode. HBLK Pattern 5 Order. Used during pixel mixing mode. HBLK Pattern 6 Order. Used during pixel mixing mode. HBLK Mode Selection. 0 = normal HBLK. 1 = pixel mixing mode. 2 = special pixel mixing mode. 3 = not used. Test Operation Only. Set to 0. Set unused bits to 0.
0x09	[12:0] [20:13] [21] [22] [27:23]	X X X X X	SCP	HBLKLEN HBLKREP HBLKMASK_H1 HBLKMASK_H2 Unused	HBLK Length in HBLK Alteration Modes. Number of HBLK Repetitions in HBLK Alternation Modes. Masking Polarity for H1/H3 During HBLK. Masking Polarity for H2/H4 During HBLK. Set unused bits to 0.
0xA	[12:0] [25:13] [27:26]	X X X	SCP	HBLKSTART HBLKEND Unused	HBLK Start Position Used in Pixel Mixing Modes. HBLK End Position Used in Pixel Mixing Modes. Set unused bits to 0.
0xB	[27:0]	X	SCP	TESTMODE	Test Operation Only. Set to 0.
0xC	[12:0] [25:13] [27:26]	X X X	SCP	CLPOB0_TOG1 CLPOB0_TOG2 Unused	CLPOB0 Toggle Position 1. CLPOB0 Toggle Position 2. Set unused bits to 0.
0xD	[12:0] [25:13] [27:26]	X X X	SCP	CLPOB1_TOG1 CLPOB1_TOG2 Unused	CLPOB1 Toggle Position 1. CLPOB1 Toggle Position 2. Set unused bits to 0.
0xE	[12:0] [25:13] [27:26]	X X X	SCP	PBLK0_TOG1 PBLK0_TOG2 Unused	PBLK0 Toggle Position 1. PBLK0 Toggle Position 2. Set unused bits to 0.
0xF	[12:0] [25:13] [27:26]	X X X	SCP	PBLK1_TOG1 PBLK1_TOG2 Unused	PBLK1 Toggle Position 1. PBLK1 Toggle Position 2. Set unused bits to 0.

Table 31. Field Registers

Address	Data Bit Content	Default Value	Update	Name	Description
0x00	[12:0] [25:13] [27:26]	X X X	VD	SCP0 SCP1 Unused	Sequence Change Position 0. Sequence Change Position 1. Set unused bits to 0.
0x01	[12:0] [25:13] [27:26]	X X X	VD	SCP2 SCP3 Unused	Sequence Change Position 2. Sequence Change Position 3. Set unused bits to 0.

Address	Data Bit Content	Default Value	Update	Name	Description
0x02	[12:0] [25:13] [27:26]	X X X	VD	SCP4 SCP5 Unused	Sequence Change Position 4. Sequence Change Position 5. Set unused bits to 0.
0x03	[12:0] [25:13] [27:26]	X X X	VD	SCP6 SCP7 Unused	Sequence Change Position 6. Sequence Change Position 7. Set unused bits to 0.
0x04	[12:0] [27:13]	X	VD	SCP8 Unused	Sequence Change Position 8. Set unused bits to 0.
0x05	[4:0] [9:5] [14:10] [19:15] [24:20] [27:25]	X X X X X X	VD	HPAT_SEL0 HPAT_SEL1 HPAT_SEL2 HPAT_SEL3 HPAT_SEL4 Unused	Selected H-Pattern for First Region in Field. Selected H-Pattern for Second Region in Field. Selected H-Pattern for Third Region in Field. Selected H-Pattern for Fourth Region in Field. Selected H-pattern for fifth region in field. Set unused bits to 0.
0x06	[4:0] [9:5] [14:10] [19:15] [27:20]	X X X X X	VD	HPAT_SEL5 HPAT_SEL6 HPAT_SEL7 HPAT_SEL8 Unused	Selected H-Pattern for Sixth Region in Field. Selected H-Pattern for Seventh Region in Field. Selected H-Pattern for Eighth Region in Field. Selected H-Pattern for Ninth Region in Field. Set unused bits to 0.
0x07	[27:0]	X	VD	Unused	Set unused bits to 0.
0x08	[8:0] [17:9] [27:18]	X X X	VD	CLPOB_POL CLPOB_PAT Unused	CLPOB Start Polarity Settings. CLPOB Pattern Selector. 0 = CLPOB0_TOG registers are used. 1 = CLPOB1_TOG registers are used. Set unused bits to 0.
0x09	[12:0] [25:13] [27:26]	X X	VD	CLPOBMASKSTART1 CLOBMASKEND1 Unused	CLPOB Mask 1 Start Position. CLPOB Mask 1 End Position. Set unused bits to 0.
0xA	[12:0] [25:13] [27:26]	X X X	VD	CLPOBMASKSTART2 CLOBMASKEND2 Unused	CLPOB Mask 2 Start Position. CLPOB Mask 2 End Position. Set unused bits to 0.
0xB	[12:0] [25:13] [27:26]	X X X	VD	CLPOBMASKSTART3 CLOBMASKEND3 Unused	CLPOB Mask 3 Start Position. CLPOB Mask 3 End Position. Set unused bits to 0.
0xC	[8:0] [17:9] [27:18]	X X X	VD	PBLK_POL PBLK_PAT Unused	PBLK Start Polarity Settings for Sequence 0 to Sequence 8. PBLK Pattern Selector. 0 = PBLK0_TOG registers are used. 1 = PBLK1_TOG registers are used. Set unused bits to 0
0xD	[12:0] [25:13] [27:26]	X X X	VD	PBLKMASKSTART1 PBLKMASKEND1 Unused	PBLK Mask Region 1 Start Position. PBLK Mask Region 1 End Position. Set unused bits to 0.
0xE	[12:0] [25:13] [27:26]	X X X	VD	PBLKMASKSTART2 PBLKMASKEND2 Unused	PBLK Mask Region 2 Start Position. PBLK Mask Region 2 End Position. Set unused bits to 0.
0xF	[12:0] [25:13] [27:26]	X X X	VD	PBLKMASKSTART3 PBLKMASKEND3 Unused	PBLK Mask Region 3 Start Position. PBLK Mask Region 3 End Position. Set unused bits to 0.

OUTLINE DIMENSIONS

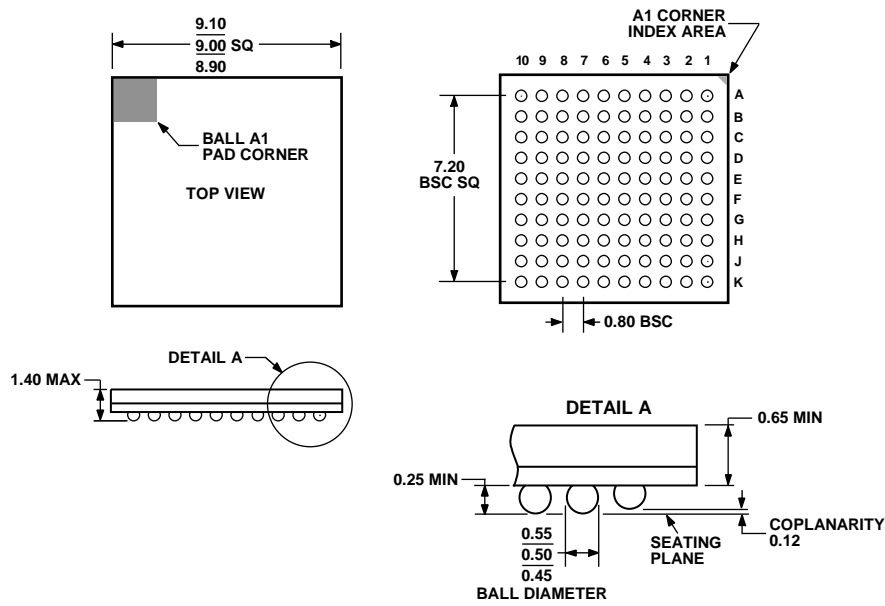

COMPLIANT TO JEDEC STANDARDS MO-205-AB.

Figure 56. 100-Lead Chip Scale Package Ball Grid Array [CSP_BGA] (BC-100-1)

Dimensions shown in millimeters

0122006-0

ORDERING GUIDE

Model	Temperature Range	Package Description	Package Option
AD9974BBCZ ¹	-25°C to +85°C	100-Lead Chip Scale Package Ball Grid Array [CSP_BGA]	BC-100-1
AD9974BBCZRL ¹	-25°C to +85°C	100-Lead Chip Scale Package Ball Grid Array [CSP_BGA]	BC-100-1

¹ Z = RoHS Compliant Part.

NOTES

AD9974

NOTES

Looking for pricing, stock, or lifecycle information?

Click below to explore more details on WIN SOURCE:

 [View AD9974BBCZ on WIN SOURCE](#)

 [Analog Devices Inc. Information](#)

Optimize Your Supply Chain with WIN SOURCE Solutions

-  Global Sourcing Solution
-  Obsolete Management
-  Cost Control Management
-  Shortage Management
-  Alternative Solution
-  Excess Inventory Management