



**THE DATASHEET OF
AD9970BCPZRL7**





FEATURES

- 1.8 V analog and digital core supply voltage
- Serial data link with reduced range LVDS outputs
- Correlated double sampler (CDS) with -3 dB, 0 dB, +3 dB, and +6 dB gain
- 6 dB to 42 dB, 10-bit variable gain amplifier (VGA)
- 14-bit, 65 MHz ADC
- Black level clamp with variable level control
- Complete on-chip timing generator
- Precision Timing core with 240 ps resolution at 65 MHz
- On-chip, 3 V horizontal and RG drivers
- 5 mm × 5 mm, 32-lead LFCSP_VQ

APPLICATIONS

- Professional HDTV camcorders
- Professional/high end digital cameras
- Broadcast cameras
- Industrial high speed cameras
- High speed data acquisition systems

GENERAL DESCRIPTION

The AD9970 is a highly integrated CCD signal processor for high speed digital video camera applications. Specified at pixel rates of up to 65 MHz, the AD9970 consists of a complete analog front end with analog-to-digital conversion combined with a programmable timing driver. The Precision Timing core allows adjustment of high speed clocks with 240 ps resolution at 65 MHz operation. The AD9970 also contains a reduced range LVDS interface for data outputs.

The analog front end includes black level clamping, CDS, VGA, and a 65 MSPS, 14-bit ADC. The timing driver provides the high speed CCD clock drivers for RG, HL, and H1 to H4. Operation is programmed using a 3-wire serial interface.

Packaged in a space-saving 5 mm × 5 mm, 32-lead LFCSP_VQ, the AD9970 is specified over an operating temperature range of -25°C to +85°C.

For more information about the AD9970, contact Analog Devices via email at afe.ccd@analog.com.

FUNCTIONAL BLOCK DIAGRAM

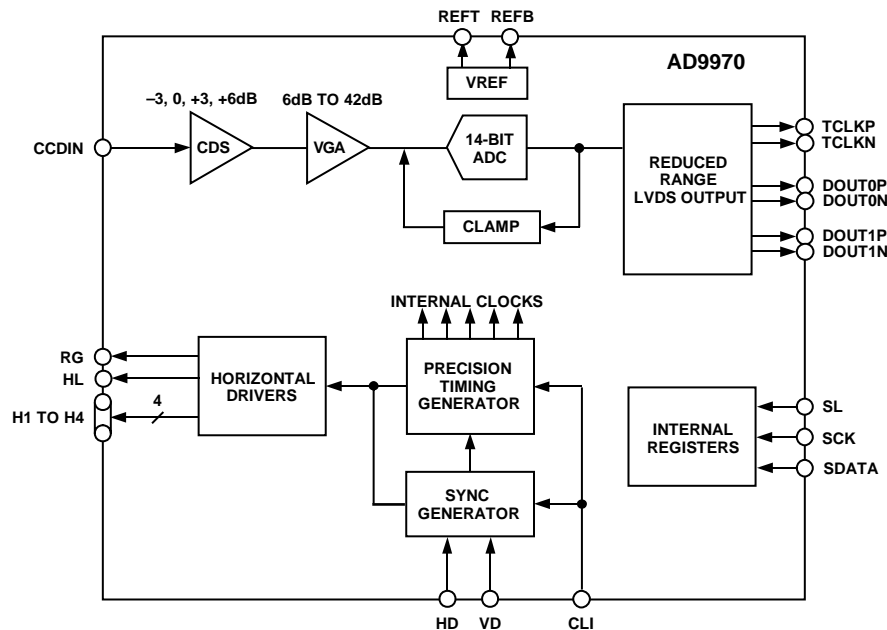

Figure 1.

NOTES

Looking for pricing, stock, or lifecycle information?

Click below to explore more details on WIN SOURCE:

⊖ [View AD9970BCPZRL7 on WIN SOURCE](#)

⊖ [Analog Devices Inc. Information](#)

Optimize Your Supply Chain with WIN SOURCE Solutions

- ✓ Global Sourcing Solution
- ✓ Obsolete Management
- ✓ Cost Control Management
- ✓ Shortage Management
- ✓ Alternative Solution
- ✓ Excess Inventory Management