





THE DATASHEET OF SD12C



SPECIFICATION SHEET

SPECIFICATION SHEET NO.	N0310- SOD323SD12CS2D
DATE	Mar. 10, 2021
REVISION	A0
DESCRIPTION	SMD Plastic-Encapsulate ESD Protection Diodes, SOD-323 series SD12C Type, Bi-directional TVS Diodes, Reverse Working Voltage : 12V, Peak Pulse Power per: 350 Watts Operating Temp. Range -55°C ~+155°C Package in Tape/Reel, 3000pcs/Reel RoHS/RoHS III compliant
CUSTOMER	
CUSTOMER PART NUMBER	
CROSS REF. PART NUMBER	
ORIGINAL PART NUMBER	MDD SD12C
PART CODE	SOD323SD12CS2D

VENDOR APPROVE			
Issued/Checked/Approved			
DATE: March 10, 2021			

CUSTOMER APPROVE	
DATE:	

SMD ESD PROTECTION DIODES (TUBE) SOD-323 SERIES

MAIN FEATURE

- 350 Watts Peak Pulse Power per (8/20μs)
- IEC61000-4-2 (ESD) ±15kV (air), ±8kV (contact)
- IEC61000-4-4 (EFT) 40A (5/50ns)
- Protects one bidirectional line
- Low clamping voltage
- Low leakage current
- Working voltages : 3V, 5V, 8V, 12V, 15V, 18V, 20V, 24V, 36V
- Meets MSL 1 Requirements



APPLICATION

- Cell Phone Handsets and Accessories
- Microprocessor based equipment
- Personal Digital Assistants (PDA's)
- Notebooks, Desktops, and Servers
- Portable Instrumentation
- Networking and Telecom
- Serial and Parallel Ports
- Peripherals

PART CODE GUIDE

RFQ

[Request For Quotation](#)

SOD323	SD12C	S	2D
1	2	3	4

- 1) **SOD323**: SMD Plastic-Encapsulate ESD Protection Diodes, SOD323 series, 2 pads
- 2) **SD12C**: Type code for original part number SD12C
- 3) **S**: Package code, Package in Tape/Reel, 3000pcs/Reel
- 4) **2D**: Marking code for "2D" on the case surface, Different Marking for different specification.

MORE ITEMS AVAILABLE

SOD323SD03CS2A	SOD323SD05CS2B	SOD323SD08CS2C	SOD323SD12CS2D	SOD323SD15CS2J
SOD323SD18CS2K	SOD323SD20CS2L	SOD323SD24CS2H	SOD323SD36CS2N	

SMD ESD PROTECTION DIODES (TUBE) SOD-323 SERIES

DIMENSION (Unit: Inch/mm)

Image for reference



Marking: 2D

SOD-323

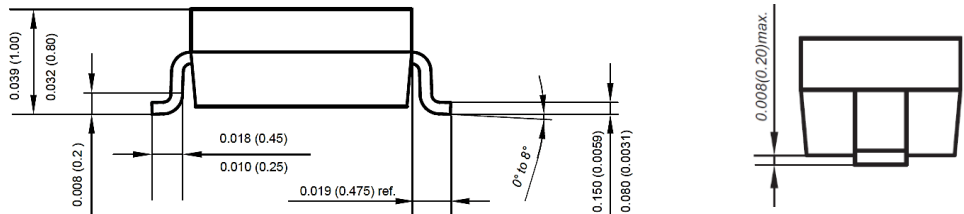
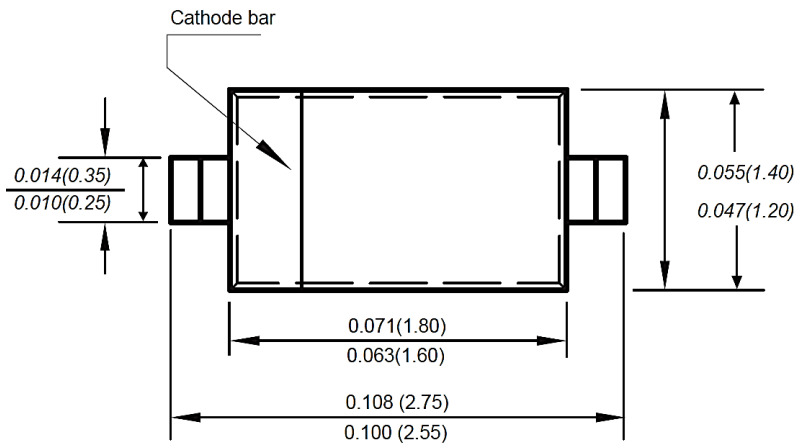

Recommend Pad Layout

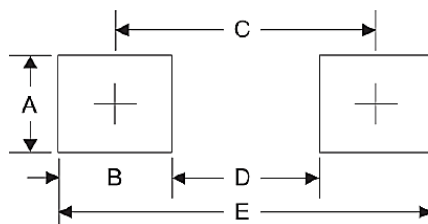

Symbol	Unit (inch)	Unit (mm)
A	0.028	0.70
B	0.028	0.70
C	0.085	2.15
D	0.071	1.80
E	0.112	2.85

SMD ESD PROTECTION DIODES (TUBE) SOD-323 SERIES
MECHANICAL DATA

Case	Terminals	High temperature soldering Guaranteed	Flammability Rating	Weight per piece
JEDEC SOD-323 molded plastic body	Matte tin plated	260°C/10s	UL 94V-0	0.00019 Ounce, 0.0059 grams

ABSOLUTE MAX. RATINGS AT Ta=25 °C (unless otherwise specified)

Parameter	SYMBOLS	VALUE	UNITS
		LIMIT	
ESD per IEC 61000-4-2 (Air)	V ESD	+/-15	KV
ESD per IEC 61000-4-2 (Contact)	V ESD	+/-8	KV
Peak Pulse Power(tp=8/20us waveform)	P PP	350	W
Operating Temperature Range	TOPT	-55 ~+ 150	°C
Storage Temperature Range	T STG	-55 ~ +150	°C
Lead Solder Temperature – Maximum (10 Second Duration)	T J	260(10 sec.)	°C

ABSOLUTE MAX. RATINGS AT Ta=25 °C (unless otherwise specified)

Parameter	SYMBOLS	VALUE			UNITS
		Min.	Typical	Max.	
Reverse Working Voltage Any I/O pin to Ground	V RWM			12	V
Reverse Breakdown Voltage @ I _T = 1.0mA Any I/O pin to Ground	V BR	13.3			V
Test Current	I T			1.0	mA
Clamping Voltage @ 1A	V C			19	V
Clamping Voltage @ 11A	V C			32	V
Reverse Leakage Current	I R			1.0	µA
Test Capacitance	C T			75	pF

Note:

1) I/O pins are pin 1,2,4,5, GND pins are pin 3,8. 2) The above data are for reference only.

SMD ESD PROTECTION DIODES (TUBE) SOD-323 SERIES
RELIABILITY

Number	Experiment Items	Experiment Method And Conditions	Reference Documents
1	Solder Resistance Test	Test 260°C± 5°C for 10 ± 2 sec. Immerse body into solder 1/16" ± 1/32"	MIL-STD-750D METHOD-2031.2
2	Solderability Test	230°C ±5°C for 5 sec.	MIL-STD-750D METHOD-2026.1 0
3	Pull Test	1 kg in axial lead direction for 10 sec.	MIL-STD-750D METHOD-2036.4
4	Bend Test	0.5Kg Weight Applied To Each Lead, Bending Arcs 90 °C ± 5 °C For 3 Times	MIL-STD-750D METHOD-2036.4
5	High Temperature Reverse Bias Test	TA=100°C for 1000 Hours at VR=80% Rated VR	MIL-STD-750D METHOD-1038.4
6	Forward Operation Life Test	TA=25°C Rated Average Rectified Current	MIL-STD-750D METHOD-1027.3
7	Intermittent Operation Life Test	On state: 5 min with rated IRMS Power Off state: 5 min with Cool Forced Air. On and off for 1000 cycles.	MIL-STD-750D METHOD-1036.3
8	Pressure Cooker Test	15 PSIG, TA=121°C, 4 hours	MIL-S-19500 APPENOIXC
9	Temperature Cycling Test	-55°C~+125°C; 30 Minutes For Dwelled Time 5 minutes for transferred time. Total: 10 cycles.	MIL-STD-750D METHOD-1051.7
10	Thermal Shock Test	0°C for 5 minutes., 100°C for 5minutes, Total: 10 cycles	MIL-STD-750D METHOD-1056.7
11	Forward Surge Test	8.3ms Single Sale Sine-wave One Surge.	MIL-STD-750D METHOD-4066.4
12	Humidity Test	TA=65°C, RH=98% for 1000 hours.	MIL-STD-750D METHOD-1021.3
13	High Temperature Storage life Test	150°C for 1000 Hours	MIL-STD-750D METHOD-1031.5

SMD ESD PROTECTION DIODES (TUBE) SOD-323 SERIES

SUGGESTED REFLOW PROFILE (For Reference Only)

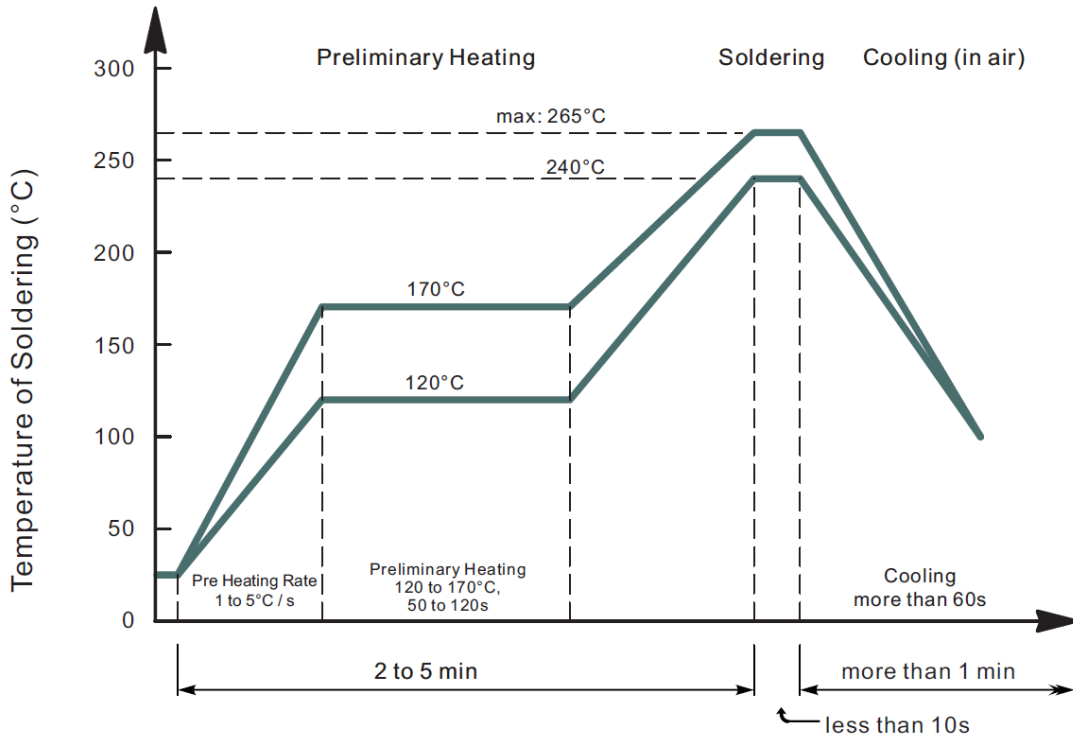

- Recommended peak temperature is over 245°C, If peak temperature is below 245 °C, you may adjust the following parameters; time length of peak temperature (longer), time length of soldering (longer), thickness of solder paste (thicker)
- Welding shall not exceed 2 times
- Remark: lead free solder paste (96.5 sn/3.0 Ag/0.5Cu)

SMD ESD PROTECTION DIODES (TUBE) SOD-323 SERIES

RATINGS AND CHARACTERISTIC CURVES (For Reference Only)

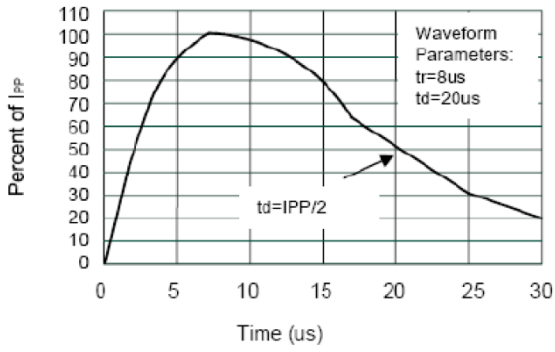

Pulse Waveform

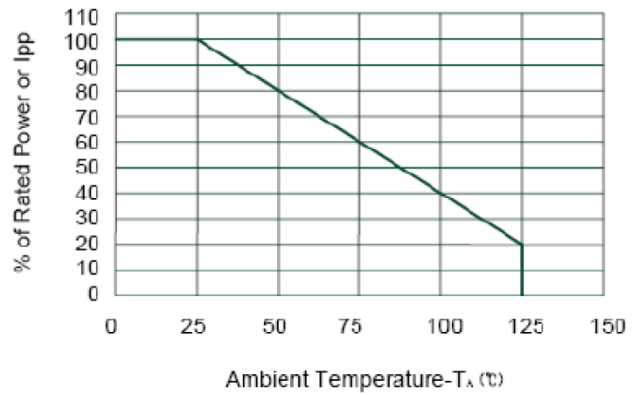

Ambient Temperature-T_a (°C)

SMD ESD PROTECTION DIODES (TUBE) SOD-323 SERIES

TAPE/REEL (Unit: mm)

All Devices are packed in accordance with EIA standard RS-481-A and specifications.

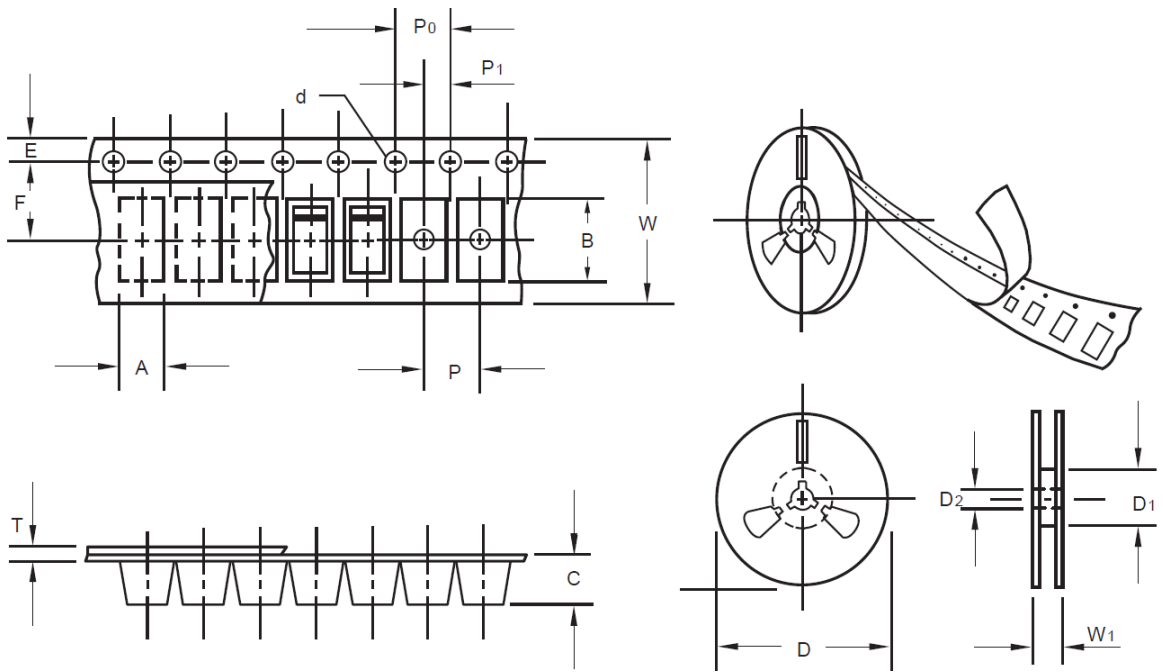

Item	Symbol	Tolerance	SOD-323
Carrier width	A	0.1	2.10
Carrier Length	B	0.1	4.00
Carrier Depth	C	0.1	1.60
Sprocket hole	d	0.05	1.55
13"Reel outside diameter	-	-	-
13"Reel inner diameter	-	-	-
7"Reel outside diameter	D	2.0	178.00
7"Reel inner diameter	D1	Min.	50.00
Feed hole diameter	D2	0.5	13.00
Sprocket hole position	E	0.1	1.75
Punch hole position	F	0.1	3.50
Punch hole pitch	P	0.1	4.00
Sprocket hole pitch	P0	0.1	4.00
Embossment center	P1	0.1	2.00
Overall tape thickness	T	0.1	0.25
Tape width	W	0.3	8.15
Reel width	W1	1.0	10.50

SMD ESD PROTECTION DIODES (TUBE) SOD-323 SERIES

PACKAGE

Case Code	Reel Size	MPQ (pcs)	Component Spacing (mm)	Qty. Per Box (pcs)	Inner Box L*W*H (mm)	Reel Size (mm)	Carton size L*W*H (mm)	Qty. Per Carton (pcs)	G. W (kg)
SOD-323	7"	3,000	-	24,000	210*208*203	178	400*400*250	180,000	8.0

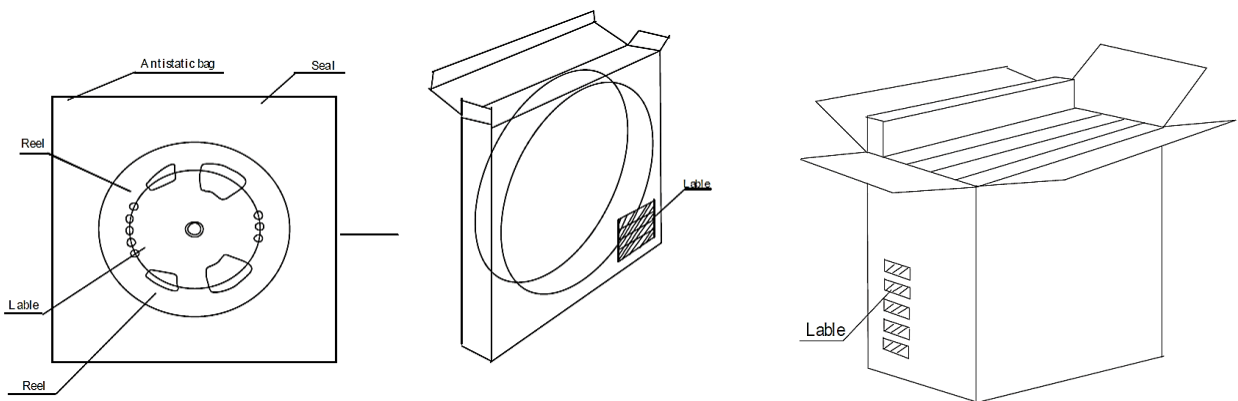

DISCLAIMER

NextGen Component, Inc. reserves the right to make changes to the product(s) and or information contained herein without notice. No liability is assumed as a result of their use or application. No rights under any patent accompany the sale of any such product(s) or information





Looking for pricing, stock, or lifecycle information?

Click below to explore more details on WIN SOURCE:

 [View SD12C on WIN SOURCE](#)

 [MDD Information](#)

Optimize Your Supply Chain with WIN SOURCE Solutions

-  Global Sourcing Solution
-  Obsolete Management
-  Cost Control Management
-  Shortage Management
-  Alternative Solution
-  Excess Inventory Management