



**THE DATASHEET OF
AD9937BCPZ-24**



FEATURES

- 12 MSPS Correlated Double Sampler (CDS)
- 10-Bit 12 MHz A/D Converter
- No Missing Codes Guaranteed
- 6 dB to 40 dB Variable Gain Amplifier (VGA)
- Black Level Clamp with Variable Level Control
- Complete On-Chip Timing Generator
- Precision Timing Core with 1.7 ns Resolution
- On-Chip: 6-Channel Horizontal and 1-Channel RS Drivers
- 4-Phase Vertical Transfer Clocks
- Electronic and Mechanical Shutter Modes
- On-Chip Sync Generator with External Sync Option

APPLICATIONS

- Digital Still Cameras
- Industrial Imaging

GENERAL DESCRIPTION

The AD9937 is a highly integrated CCD signal processor. It includes a complete analog front end with A/D conversion, combined with a full-function programmable timing generator. A Precision Timing core allows adjustment of high speed clocks with 1.7 ns resolution at 12 MHz operation.

The AD9937 is specified at pixel rates of up to 12 MHz. The analog front end includes black level clamping, CDS, VGA, and a 10-bit A/D converter. The timing generator provides all the necessary CCD clocks: RS, H-clocks, V-clocks, sensor gate pulses, and substrate charge reset pulse. Operation is programmed using a 3-wire serial interface.

The AD9937 is packaged in a 56-lead LFCSP and specified over an operating temperature range of -25°C to $+85^{\circ}\text{C}$.

FUNCTIONAL BLOCK DIAGRAM

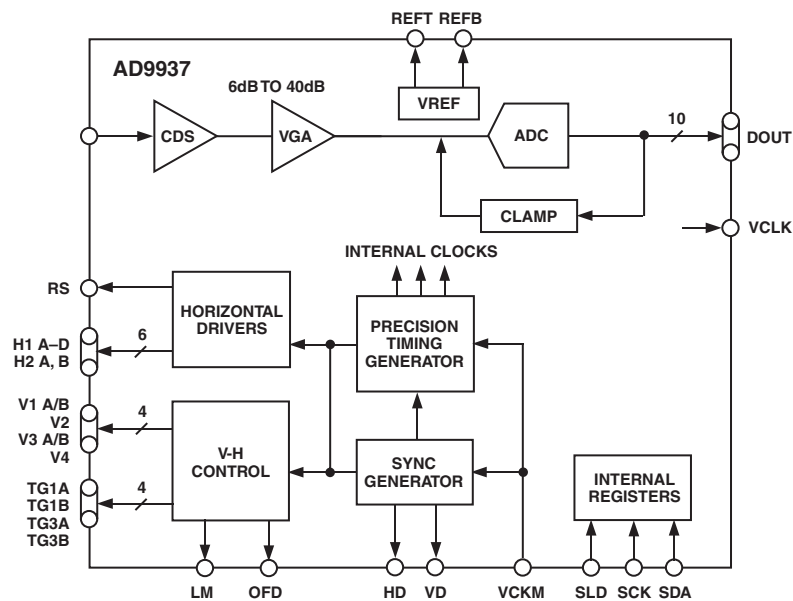

REV. 0

Information furnished by Analog Devices is believed to be accurate and reliable. However, no responsibility is assumed by Analog Devices for its use, nor for any infringements of patents or other rights of third parties that may result from its use. No license is granted by implication or otherwise under any patent or patent rights of Analog Devices. Trademarks and registered trademarks are the property of their respective companies.

AD9937

TABLE OF CONTENTS

FEATURES	1	HORIZONTAL AND VERTICAL TIMING	25
APPLICATIONS	1	Individual HMASK Sequence	25
GENERAL DESCRIPTION	1	Individual PBLK Sequences	25
FUNCTIONAL BLOCK DIAGRAM	1	Controlling CLPOB Clamp Pulse Timing	28
SPECIFICATIONS	3	Vertical Sensor Transfer Gate Timing	29
DIGITAL SPECIFICATIONS	3	SHUTTER TIMING CONTROL	29
ANALOG SPECIFICATIONS	4	Normal Shutter Mode	29
TIMING SPECIFICATIONS	5	High Precision Shutter Mode	29
ABSOLUTE MAXIMUM RATINGS	5	Controlling LM Pulse Timing	31
PACKAGE THERMAL CHARACTERISTICS	5	SPECIAL HORIZONTAL PATTERN TIMING	32
ORDERING GUIDE	5	MASKING H1 AND H2 OUTPUTS	33
PIN CONFIGURATION	6	Horizontal Masking	33
PIN FUNCTION DESCRIPTIONS	6	Vertical Masking	33
TERMINOLOGY	7	VERTICAL TIMING GENERATION	35
Differential Nonlinearity	7	CCD REGIONS	35
Peak Nonlinearity	7	POWER-UP	39
Total Output Noise	7	STANDBY SEQUENCE	40
Power Supply Rejection	7	POWER-DOWN SEQUENCE	41
EQUIVALENT CIRCUITS	7	CIRCUIT LAYOUT INFORMATION	42
TYPICAL PERFORMANCE CHARACTERISTICS	8	OUTLINE DIMENSIONS	44
REGISTER MAPS	9	TABLES	
SERIAL INTERFACE TIMING	18	Table I. Control Register Map	9
Control Register Serial Interface	18	Table II. VTP Sequence System Register Map	10
System and Mode Register Serial Interface	18	Table III. H/LM System Register Map	12
Page/Burst Option	18	Table IV. Shutter System Register Map	13
Random Access Option	18	Table V. Mode_A	14
Internal Power-On Reset Circuitry	19	Table VI. Mode_B	16
VD Synchronous and Asynchronous Register Operation	19	Table VII. Serial Interface Registers	18
Asynchronous Register Operation	19	Table VIII. RS, H1, SHP, SHD, and DOUTPHASE	
VD Synchronous Register Operation	19	Timing Parameters	23
SYSTEM OVERVIEW	20	Table IX. Precision Timing Edge Locations for RS, H1,	
ANALOG FRONT END DESCRIPTION AND		SHP, SHD, and DOUTPHASE	23
OPERATION	21	Table X. HD and VD Registers	25
DC Restore	21	Table XI. PBLK Registers	26
Correlated Double Sampler	21	Table XII. CLPOB Registers	28
PRECISION TIMING HIGH SPEED TIMING		Table XIII. TG Registers	29
GENERATION	22	Table XIV. OFD Registers	30
Timing Resolution	22	Table XV. LM Registers	31
High Speed Clock Programmability	22	Table XVI. Special H Pattern Registers	33
H-Driver and RS Outputs	22	Table XVII. Sequence Change Positions Registers	35
MASTER AND SLAVE MODE OPERATION	25	Table XVIII. Start-Up Polarities	39

AD9937—SPECIFICATIONS

Parameter	Min	Typ	Max	Unit
TEMPERATURE RANGE				
Operating	-25		+85	°C
Storage	-65		+150	°C
POWER SUPPLY VOLTAGE				
AVDD (AFE Analog Supply)	2.7	3.0	3.6	V
TCVDD (Timing Core Analog Supply)	2.7	3.0	3.6	V
RSVDD (RS Driver)	2.7	3.0	3.6	V
HVDD1 (H1A, H2A, and H1C Drivers)	2.7	3.0	3.6	V
HVDD2 (H1B, H2B, and H1D Drivers)	2.7	3.0	3.6	V
DRVDD (Data Output Drivers)	2.7	3.0	3.6	V
DVDD (Digital)	2.7	3.0	3.6	V
POWER CONSUMPTION @ 10 MHz				
Power from (AVDD + TCVDD + DRVDD + DVDD)		100		mW
Power from (HVDD1 + HVDD2) ¹		25		mW
Power from (RSVDD) ²		3		mW
Standby Mode (AFE_STBY and DIG_STBY = 0)		1.5		mW
VCKM MAX CLOCK RATE	12			MHz

NOTES

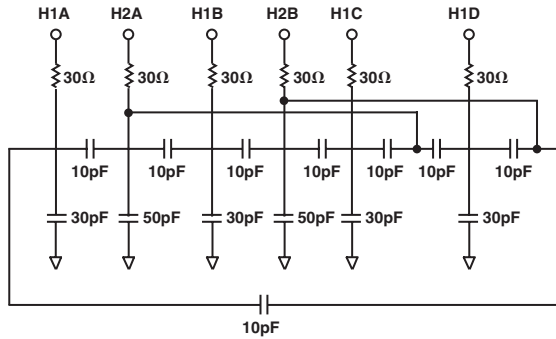

¹H1 (A–D) and H2 (A, B) Loads

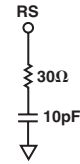

²RS Load

DIGITAL SPECIFICATIONS (RSVDD = HVDD = 2.7 V to 3.6 V, -25°C to +85°C, unless otherwise noted.)

Parameter	Symbol	Min	Typ	Max	Unit
LOGIC INPUTS (VCKM, SLD, SDA, and SCK)					
High Level Input Voltage	V_{IH}	2.1			V
Low Level Input Voltage	V_{IL}			0.6	V
High Level Input Current	I_{IH}			40	μA
Low Level Input Current	I_{IL}			40	μA
Input Capacitance	C_{IN}		10		pF
LOGIC OUTPUTS (Except H1(A–D), H2(A, B), and RS)					
High Level Output Voltage @ $I_{OH} = 2$ mA	V_{OH}	DRVDD – 0.5			V
Low Level Output Voltage @ $I_{OL} = 2$ mA	V_{OL}			0.5	V
H-DRIVER OUTPUTS (H1(A–D), H2(A, B))					
High Level Output Voltage @ Max Current	V_{OH}	DVDD – 0.5			V
Low Level Output Voltage @ Max Current	V_{OL}			0.5	V
H1(A–D) Maximum Output Current (Programmable)		12.25			mA
H2(A, B) Maximum Output Current (Programmable)		12.25			mA
Maximum Load Current		100			pF
RS-DRIVER OUTPUTS					
High Level Output Voltage @ Max Current	V_{OH}	RSVDD – 0.5			V
Low Level Output Voltage @ Max Current	V_{OL}			0.5	V
RS Maximum Output Current (Programmable)		12.25			mA
Maximum Load Current		100			pF

Specifications subject to change without notice.

AD9937

ANALOG SPECIFICATIONS (AVDD = 3 V, f_{CLK} = 12 MHz, -25°C to +85°C, unless otherwise noted.)

Parameter	Min	Typ	Max	Unit	Notes
CDS					
Allowable CCD Reset Transient		500		mV	Input signal characteristics.*
Max Input Range before Saturation	1.0			V p-p	
Max CCD Black Pixel Amplitude		±100		mV	
VARIABLE GAIN AMPLIFIER (VGA)					
Max Output Range	2.0		10	V p-p	
Gain Control Resolution		Guaranteed		Bits	
Gain Monotonicity		Guaranteed			
Gain Range					
Low Gain (VGA Code 0)		5.3		dB	
Max Gain (VGA Code 1023)	40	41.1		dB	
BLACK LEVEL CLAMP					
Clamp Level Resolution		255		Steps	LSB measured at ADC output.
Clamp Level					
Min Clamp Level		0		LSB	
Max Clamp Level		63.75		LSB	
A/D CONVERTER					
Resolution	10			Bits	
Differential Nonlinearity (DNL)		±0.4	±1.0	LSB	
No Missing Codes		Guaranteed			
Full-Scale Input Voltage		2.0		V	
VOLTAGE REFERENCE					
Reference Top Voltage (REFT)		2.0		V	
Reference Bottom Voltage (REFB)		1.0		V	
SYSTEM PERFORMANCE					Includes entire signal chain.
Gain Accuracy					Gain = (0.035 × Code) + 5.4 dB
Low Gain (VGA Code 17)	5	6	7	dB	
Max Gain (VGA Code 1023)	40.2	41.2	42.2	dB	
Peak Nonlinearity, 500 mV Input Signal		0.1		%	12 dB gain applied.
Total Output Noise		0.3		LSB rms	AC ground input, 6 dB gain applied.
Power Supply Rejection (PSR)		40		dB	Measured with step change on supply.

*Input signal characteristics defined as follows:

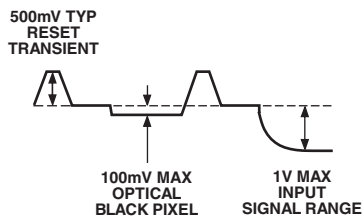

Specifications subject to change without notice.

TIMING SPECIFICATIONS ($C_L = 20$ pF, $AVDD = DVDD = DRVDD = 3$ V, $f_{CL} = 12$ MHz, unless otherwise noted.)

Parameter	Symbol	Min	Typ	Max	Unit
MASTER CLOCK, VCKM					
VCKM Clock Period	t_{CONV}	83.33			ns
VCKM High/Low Pulsewidth			41.67		ns
Delay from VCKM Rising Edge to Internal Pixel Position 0	$t_{VCKMDLY}$		9		ns
AFE CLAMP PULSES ¹					
CLPOB Pulsewidth ²		2	20		Pixels
AFE SAMPLE LOCATION ¹ (See Figure 13)					
SHP Sample Edge to SHD Sample Edge	t_{S1}	33.34	41.67		ns
DATA OUTPUTS					
Output Delay from VCLK Rising Edge	t_{OD}		9		ns
Pipeline Delay from SHP/SHD Sampling (See Figure 40)			9		Cycles
SERIAL INTERFACE					
Maximum SCK Frequency	f_{SCLK}	10			MHz
SLD to SCK Setup Time	t_{LS}	10			ns
SCK to SLD Hold Time	t_{LH}	10			ns
SDA Valid to SCK Rising Edge Setup	t_{DS}	10			ns
SCK Falling Edge to SDA Valid Hold	t_{DH}	10			ns
SCK Falling Edge to SDA Valid Read	t_{DV}	10			ns

NOTES

¹Parameter is programmable.²Minimum CLPOB pulsewidth is for functional operation only. Wider typical pulses are recommended to achieve good clamp performance.

Specifications subject to change without notice.

ABSOLUTE MAXIMUM RATINGS

Parameter	With Respect To	Min Max		Unit
		Min	Max	
AVDD	AVSS	-0.3	+3.9	V
TCVDD	TCVSS	-0.3	+3.9	V
HVDD	HVSS	-0.3	+3.9	V
RSVDD	RSVSS	-0.3	+3.9	V
DVDD	DVSS	-0.3	+3.9	V
DRVDD	DRVSS	-0.3	+3.9	V
RS Output	RSVSS	-0.3	RSVDD + 0.3	V
H1 (A-D), H2 (A, B) Output	HVSS	-0.3	HVDD + 0.3	V
Digital Outputs	DVSS	-0.3	DVDD + 0.3	V
Digital Inputs	DVSS	-0.3	DVDD + 0.3	V
SCK, SLD, SDA	DVSS	-0.3	DVDD + 0.3	V
VRT, VRB	AVSS	-0.3	AVDD + 0.3	V
CCDIN	AVSS	-0.3	AVDD + 0.3	V
Junction Temperature			150	°C
Lead Temperature, 10 sec			350	°C

PACKAGE THERMAL CHARACTERISTICS

Thermal Resistance

$\theta_{JA} = 24.9^{\circ}\text{C/W}$

ORDERING GUIDE

Model	Temperature Range	Package Description	Package Option
AD9937KCP	-25°C to +85°C	Lead Frame Chip Scale Package (LFCSP)	CP-56
AD9937KCPRL	-25°C to +85°C	Lead Frame Chip Scale Package (LFCSP)	CP-56

CAUTION

ESD (electrostatic discharge) sensitive device. Electrostatic charges as high as 4000 V readily accumulate on the human body and test equipment and can discharge without detection. Although the AD9937 features proprietary ESD protection circuitry, permanent damage may occur on devices subjected to high energy electrostatic discharges. Therefore, proper ESD precautions are recommended to avoid performance degradation or loss of functionality.



PIN CONFIGURATION

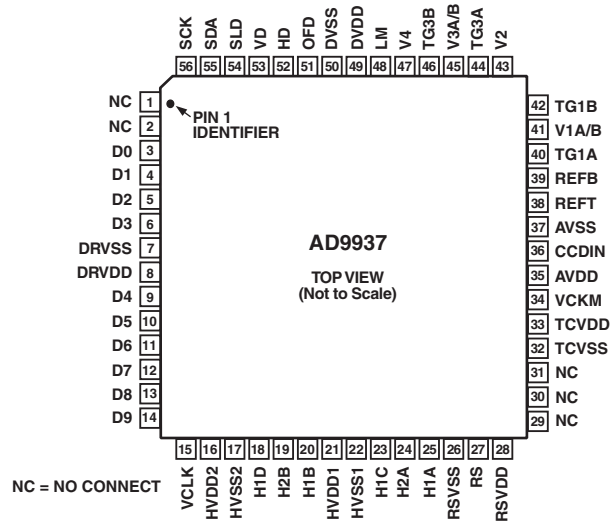

PIN FUNCTION DESCRIPTIONS¹

Pin No.	Mnemonic	Type ²	Description	Pin No.	Mnemonic	Type ²	Description
1	NC	NC	No Connect	31	NC	NC	No Connect
2	NC	NC	No Connect	32	TCVSS	P	Analog Ground for Timing Core
3	D0	DO	Data Output	33	TCVDD	P	Analog Supply for Timing Core
4	D1	DO	Data Output	34	VCKM	DI ³	Reference Clock Input
5	D2	DO	Data Output	35	AVDD	P	Analog Supply for AFE
6	D3	DO	Data Output	36	CCDIN	AI	CCD Input Signal
7	DRVSS	P	Data Output Driver Ground	37	AVSS	P	Analog Ground for AFE
8	DRVDD	P	Data Output Driver Supply	38	REFT	AO	Voltage Reference Top Bypass
9	D4	DO	Data Output	39	REFV	AO	Voltage Reference Bottom Bypass
10	D5	DO	Data Output	40	TG1A	DO	CCD Sensor Gate Pulse 1
11	D6	DO	Data Output	41	V1A/B	DO	CCD Vertical Transfer Clock 1
12	D7	DO	Data Output	42	TG1B	DO	CCD Sensor Gate Pulse 2
13	D8	DO	Data Output	43	V2	DO	CCD Vertical Transfer Clock 2
14	D9	DO	Data Output	44	TG3A	DO	CCD Sensor Gate Pulse 3
15	VCLK	DO	Data Output Clock	45	V3A/B	DO	CCD Vertical Transfer Clock 3
16	HVDD2	P	Horizontal Driver Supply 2 for H1D, H2B, and H1B	46	TG3B	DO	CCD Sensor Gate Pulse 4
17	HVSS2	P	Horizontal Driver Ground 2	47	V4	DO	CCD Vertical Transfer Clock 4
18	H1D	DO	CCD Horizontal Clock 4	48	LM	DO	Line Memory Control Pulse
19	H2B	DO	CCD Horizontal Clock 6	49	DVDD	P	Digital Supply
20	H1B	DO	CCD Horizontal Clock 2	50	DVSS	P	Digital Ground
21	HVDD1	P	Horizontal Driver Supply 1 for H1C, H2A, and H1A	51	OFD	DO	CCD Substrate Reset Pulse
22	HVSS1	P	Horizontal Driver Ground 1	52	HD	DO	Horizontal Sync Pulse
23	H1C	DO	CCD Horizontal Clock 3	53	VD	DO	Vertical Sync Pulse
24	H2A	DO	CCD Horizontal Clock 5	54	SLD	DI ³	3-Wire Serial Load Pulse
25	H1A	DO	CCD Horizontal Clock 1	55	SDA	DI ³	3-Wire Serial Data
26	RSVSS	P	RS Driver Ground	56	SCK	DI ³	3-Wire Serial Clock
27	RS	DO	CCD Reset Gate Clock				
28	RSVDD	P	RS Driver Supply				
29	NC	NC	No Connect				
30	NC	NC	No Connect				

NOTES

¹See Figure 41 for circuit configuration.

²AI = Analog Input, AO = Analog Output, DI = Digital Input,

DO = Digital Output, DIO = Digital Input/Output, P = Power,

NC = No Connection.

³Schmitt trigger type input.

TERMINOLOGY

Differential Nonlinearity (DNL)

An ideal ADC exhibits code transitions that are exactly 1 LSB apart. DNL is the deviation from this ideal value. Thus, every code must have a finite width. No missing codes guaranteed to 10-bit resolution indicates that all 1024 codes must be present over all operating conditions.

Peak Nonlinearity

Peak nonlinearity, a full signal chain specification, refers to the peak deviation of the output of the AD9937 from a true straight line. The point used as zero scale occurs 1/2 LSB before the first code transition. Positive full scale is defined as a level 1 1/2 LSB beyond the last code transition. The deviation is measured from the middle of each particular output code to the true straight line. The error is then expressed as a percentage of the 2 V ADC full-scale signal. The input signal is always appropriately gained up to fill the ADC's full-scale range.

Total Output Noise

The rms output noise is measured using histogram techniques. The standard deviation of the ADC output codes is calculated in LSB and represents the rms noise level of the total signal chain at the specified gain setting. The output noise can be converted to an equivalent voltage, using the relationship

$$1 \text{ LSB} = \left(\text{ADC Full Scale} / 2^N \text{ codes} \right)$$

where N is the bit resolution of the ADC. For the AD9937, 1 LSB is 1.95 mV.

Power Supply Rejection (PSR)

The PSR is measured with a step change applied to the supply pins. This represents a very high frequency disturbance on the AD9937's power supply. The PSR specification is calculated from the change in the data outputs for a given step change in the supply voltage.

EQUIVALENT CIRCUITS

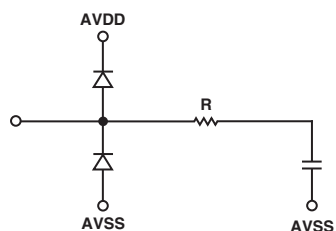

Figure 1. CCDIN

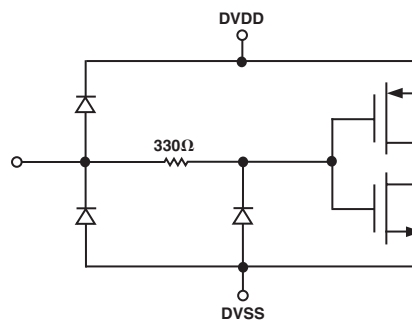

Figure 3. Digital Inputs

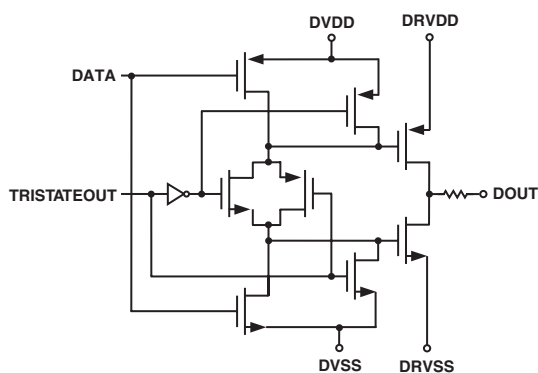

Figure 2. Digital Data Outputs

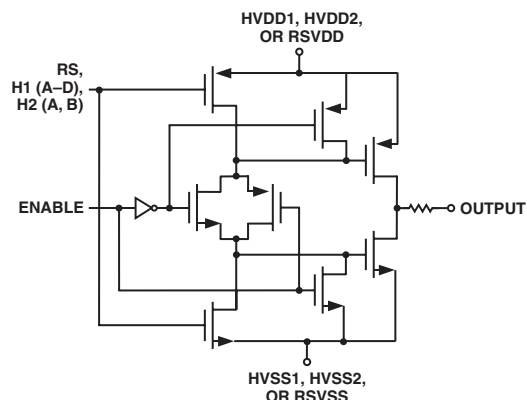
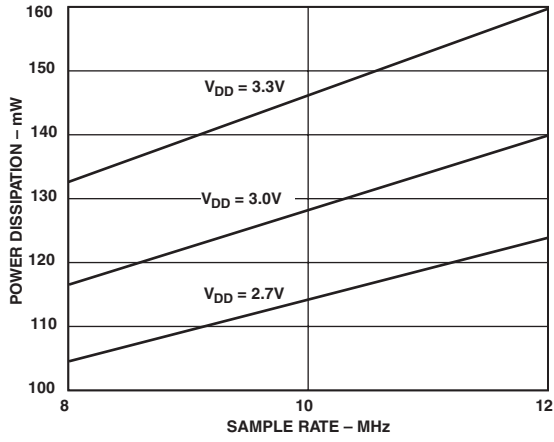
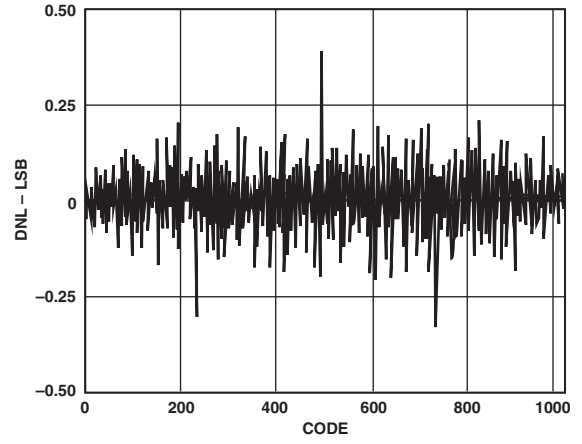

Figure 4. H1(A-D), H2(A, B), and RS Drivers

AD9937—Typical Performance Characteristics



TPC 1. Power vs. Sample Rate



TPC 2. Typical DNL Performance

Table I. Control Register Map

Addr	Bit Breakdown	Bit Width	Default	Register Name	Function
0	(23:0)	24	0	SW_RESET	Software Reset = 000000 (Reset All Registers to Default).
1	0 (23:1)	1 23	0	OUTCONT_REG Unused	Internal OUTCONT Signal Control (0 = Digital Outputs held at fixed dc level, 1 = Normal Operation).
2	(1:0) 2 (23:3)	2 1 21	0 0	AFE_STBY DIG_STBY Unused	AFE Standby (0 = Full Standby, 1 = Normal Operation, 2/3 = Reference Standby). Digital Standby (0 = Full Standby, 1 = Normal Operation).
3	(7:0) 8 9 10 11 12 13 14 (16:15) 17 18 (23:19)	8 1 1 1 1 1 1 2 1 1 5	0x80 1 0 0 0 0 0 0 0 1	REFBLACK BC_EN TESTMODE TESTMODE PBLK_LEVEL TRISTATEOUT RETIMEOUT_BAR GRAY_ENCODE TESTMODE TESTMODE TESTMODE Unused	Black Clamp Level. 1 = Black Clamp Enable. This register should always be set to 0. This register should always be set to 0. 0 = Blank to 0, 1 = Blank to Clamp Level (REFBLACK). 0 = Data Outputs are Driven, 1 = Data Outputs are Three-States. 0 = Retime Data Outputs, 1 = Do Not Retime Data Outputs. 1 = Gray Encode ADC Outputs. This register should always be set to 0. This register should always be set to 0. This register should always be set to 1.
4	0 1 2 3 4 5 (23:6)	1 1 1 1 1 1 18	0 0 0 0 0 0	VCKM_DIVIDE H1BLKRETIME LM_INVERT TGOFD_INVERT VDHD_INVERT MASTER Unused	VCKM Input Clock Divider (0 = VCKM, 1 = VCKM/2). Retimes the H1 HBLK to Internal Clock. LM Inversion Control (1 = Invert Programmed LM). TG and OFD Inversion Control (1 = Invert Programmed TG and ODF). VD and HD Inversion Control (1 = Invert Programmed VD and HD; Note that Internal VD/HD Are HI Active). Operating Mode (0 = Slave Mode, 1 = Master Mode).
5	(5:0) (11:6) (17:12) (19:18) 20 21 22 23	6 6 6 2 1 1 1 1	0x00 0x24 0x00 0x00 0 1 0 -	SHDLOC SHPLOC DOUTPHASE DOUT_DELAY VCLKMASK VCLK_INVERT DTEST Unused	SHD Sample Location. SHP Sample Location. Data Output [9:0] and VCLK Phase Adjustment. Data Output Clock Selection (0 = No Delay, 1 = ~4 ns, 2 = ~8 ns, 3 = ~12 ns). VCLK Masking Control (1 = Mask). 1 = Invert VCLK. 1 = Internal Digital Signal Test Mode.
6	(5:0) (11:6) (17:12) (23:18)	6 6 6 6	0x00 0x20 0x00 0x10	H1POSLOC H1NEGLOC RSPOSLOC RSNEGLOC	H1 Positive Edge Location. H1 Negative Edge Location. RS Positive Edge Location. RS Negative Edge Location.
7	(2:0) (5:3) (8:6) (23:9) (23:1)	3 3 3 15 23	4 4 4	H1DRV H2DRV RSDRV Unused Unused	H1A/B/C/D Drive Strength (0 = OFF, 1 = 1.75 mA, 2 = 3.5 mA, 3 = 5.25 mA, 4 = 7 mA, 5 = 8.75 mA, 6 = 10.5 mA, 7 = 12.25 mA). H2A/B Drive Strength (see H1DRV). RS Drive Strength (see H1DRV).

Table I. Control Register Map (continued)

Addr	Bit Breakdown	Bit Width	Default	Register Name	Function
8	0 (23:1)	1 23	0	MODE Unused	Mode Control Bit. (0 = Mode A, 1 = Mode B)
9	0 (4:1) (23:5)	1 4 19	1 0x9	SPEN SPLOGIC Unused	Single Pulse (SP) Output Enable. Single Pulse Logic Setting (0 = OR, 1 = AND).
10	0 (11:1) 12 (23:13)	1 11 1 11	1 0x7FF 1	OFDEN OFDNUM TGEN Unused	OFD Output Enable Control (0 = Disable, 1 = Enable). Total Number of OFD Pulses per Field. TG Output Enable Control (0 = Disable, 1 = Enable).
11	(11:0) (23:12)	12 12	4095 4095	OFDHPTOG1 OFDHPTOG2	High Precision OFD Toggle Position 1. High Precision OFD Toggle Position 2.
12	(9:0) (23:10)	10 14	0x000	VGAGAIN Unused	VGA Gain Control.

□ Denotes VD synchronous registers (control addresses 8, 9, 10, 11, and 12).

Table II. VTP Sequence System Register Map (Addr 0x14)

Addr	Bit Breakdown	Bit Width	Default	Register Name	Function
VTP_Reg(0)	(11:0) (23:12) (31:24)	12 12 8		ENDADDRESS STARTADDRESS VTP_Reg_Addr	Sub Word End Address Sub Word Start Address System Register Address 0x14
VTP_Reg(1)	(8:0) (17:9) (26:18) 27 28 29 30 31	9 9 9 1 1 1 1 1	279 75 250 1 0 0 1	VTPLen_0 V1TOG1_0 V1TOG2_0 V1POL_0 V2POL_0 V3POL_0 V4POL_0 Unused	VTP0: Length between Repetitions VTP0: V1 Toggle Position 1 VTP0: V1 Toggle Position 2 VTP0: V1 Start Polarity VTP0: V2 Start Polarity VTP0: V3 Start Polarity VTP0: V4 Start Polarity
VTP_Reg(2)	(8:0) (17:9) (26:18) (31:27)	9 9 9 5	40 145 110	V2TOG1_0 V2TOG2_0 V3TOG1_0 Unused	VTP0: V2 Toggle Position 1 VTP0: V2 Toggle Position 2 VTP0: V3 Toggle Position 1
VTP_Reg(3)	(8:0) (17:9) (26:18) (31:27)	9 9 9 5	215 5 180	V3TOG2_0 V4TOG1_0 V4TOG2_0 Unused	VTP0: V3 Toggle Position 2 VTP0: V4 Toggle Position 1 VTP0: V4 Toggle Position 2
VTP_Reg(4)	(8:0) (17:9) (26:18) 27 28 29 30 31	9 9 9 1 1 1 1 1	99 29 99 1 0 0 1	VTPLen_1 V1TOG1_1 V1TOG2_1 V1POL_1 V2POL_1 V3POL_1 V4POL_1 Unused	VTP1: Length between Repetitions VTP1: V1 Toggle Position 1 VTP1: V1 Toggle Position 2 VTP1: V1 Start Polarity VTP1: V2 Start Polarity VTP1: V3 Start Polarity VTP1: V4 Start Polarity
VTP_Reg(5)	(8:0) (17:9) (26:18) (31:27)	9 9 9 5	15 57 43	V2TOG1_1 V2TOG2_1 V3TOG1_1 Unused	VTP1: V2 Toggle Position 1 VTP1: V2 Toggle Position 2 VTP1: V3 Toggle Position 1

Table II. VTP Sequence System Register Map (Addr 0x14) (continued)

Addr	Bit Breakdown	Bit Width	Default	Register Name	Function
VTP_Reg(6)	(8:0)	9	85	V3TOG2_1	VTP1: V3 Toggle Position 2
	(17:9)	9	1	V4TOG1_1	VTP1: V4 Toggle Position 1
	(26:18)	9	71	V4TOG2_1	VTP1: V4 Toggle Position 2
	(31:27)	5		Unused	
VTP_Reg(7)	(8:0)	9	99	VTPLEN_2	VTP2: Length between Repetitions
	(17:9)	9	29	V1TOG1_2	VTP2: V1 Toggle Position 1
	(26:18)	9	99	V1TOG2_2	VTP2: V1 Toggle Position 2
	27	1	1	V1POL_2	VTP2: V1 Start Polarity
	28	1	0	V2POL_2	VTP2: V2 Start Polarity
	29	1	0	V3POL_2	VTP2: V3 Start Polarity
	30	1	1	V4POL_2	VTP2: V4 Start Polarity
	31	1		Unused	
VTP_Reg(8)	(8:0)	9	15	V2TOG1_2	VTP2: V2 Toggle Position 1
	(17:9)	9	57	V2TOG2_2	VTP2: V2 Toggle Position 2
	(26:18)	9	43	V3TOG1_2	VTP2: V3 Toggle Position 1
	(31:27)	5		Unused	
VTP_Reg(9)	(8:0)	9	85	V3TOG2_2	VTP2: V3 Toggle Position 2
	(17:9)	9	1	V4TOG1_2	VTP2: V4 Toggle Position 1
	(26:18)	9	71	V4TOG2_2	VTP2: V4 Toggle Position 2
	(31:27)	5		Unused	
VTP_Reg(10)	(11:0)	12	40	SP1TOG1	SP1 Toggle Position 1 (V1A/V1B)
	(23:12)	12	410	SP1TOG2	SP1 Toggle Position 2 (V1A/V1B)
	(31:24)	8		Unused	
VTP_Reg(11)	(11:0)	12	490	SP2TOG1	SP2 Toggle Position 1 (V2)
	(23:12)	12	780	SP2TOG2	SP2 Toggle Position 2 (V2)
	(31:24)	8		Unused	
VTP_Reg(12)	(11:0)	12	80	SP3TOG1	SP3 Toggle Position 1 (V3A/V3B)
	(23:12)	12	360	SP3TOG2	SP3 Toggle Position 2 (V3A/V3B)
	(31:24)	8		Unused	
VTP_Reg(13)	(11:0)	12	450	SP4TOG1	SP4 Toggle Position 1 (V4)
	(23:12)	12	820	SP4TOG2	SP4 Toggle Position 2 (V4)
	(31:24)	8		Unused	

Table III. H/LM System Register Map (Addr 0x15)

Addr	Bit Breakdown	Bit Width	Default	Register Name	Function
HLM_Reg(0)	(11:0) (23:12) (31:24)	12 12 8		ENDADDRESS STARTADDRESS HLM_Reg_Addr	Sub Word End Address Sub Word Start Address System Register Address 0x15
HLM_Reg(1)	0 1 2 3 4 5 (31:6)	1 1 1 1 1 1 26	0 0 1 1 0 0	H1APOL H1BPOL H1CPOL H1DPOL H2APOL H2BPOL Unused	H1A Special H-Pattern Start Polarity H1B Special H-Pattern Start Polarity H1C Special H-Pattern Start Polarity H1D Special H-Pattern Start Polarity H2A Special H-Pattern Start Polarity H2B Special H-Pattern Start Polarity
HLM_Reg(2)	(5:0) (11:6) (17:12) (31:18)	6 6 6 14	0x00 0x04 0x01	SPH1A1 SPH1B1 SPH1C1 Unused	H1A Special H-Pattern during LM Repetition 1 H1B Special H-Pattern during LM Repetition 1 H1C Special H-Pattern during LM Repetition 1
HLM_Reg(3)	(5:0) (11:6) (17:12) (31:18)	6 6 6 14	0x07 0x08 0x22	SPH1D1 SPH2A1 SPH2B1 Unused	H1D Special H-Pattern during LM Repetition 1 H2A Special H-Pattern during LM Repetition 1 H2B Special H-Pattern during LM Repetition 1
HLM_Reg(4)	(5:0) (11:6) (17:12) (31:18)	6 6 6 14	0x34 0x34 0x04	SPH1A2 SPH1B2 SPH1C2 Unused	H1A Special H-Pattern during LM Repetition 2 H1B Special H-Pattern during LM Repetition 2 H1C Special H-Pattern during LM Repetition 2
HLM_Reg(5)	(5:0) (11:6) (17:12) (31:18)	6 6 6 14	0x04 0x3A 0x0B	SPH1D2 SPH2A2 SPH2B2 Unused	H1D Special H-Pattern during LM Repetition 2 H2A Special H-Pattern during LM Repetition 2 H2B Special H-Pattern during LM Repetition 2
HLM_Reg(6)	(5:0) (11:6) (17:12) (31:18)	6 6 6 14	0x3D 0x3F 0x3C	SPH1A3 SPH1B3 SPH1C3 Unused	H1A Special H-Pattern during LM Repetition 3 H1B Special H-Pattern during LM Repetition 3 H1C Special H-Pattern during LM Repetition 3
HLM_Reg(7)	(5:0) (11:6) (17:12) (31:18)	6 6 6 14	0x3C 0x03 0x02	SPH1D3 SPH2A2 SPH2B3 Unused	H1D Special H-Pattern during LM Repetition 3 H2A Special H-Pattern during LM Repetition 3 H2B Special H-Pattern during LM Repetition 3
HLM_Reg(8)	(7:0) (15:8) (23:16) (31:24)	8 8 8 8	99 5 55 87	LMLLEN0 LMTOG1_0 LMTOG2_0 SPHSTART0	LM Pattern 0 (LM0): LM Counter Length LM Pattern 0 (LM0): Toggle Position 1 LM Pattern 0 (LM0): Toggle Position 2 LM Pattern 0 (LM0): Special H Pulse Start Position
HLM_Reg(9)	(7:0) (15:8) (23:16) (31:24)	8 8 8 8	29 2 26 0	LMLLEN1 LMTOG1_1 LMTOG2_1 SPHSTART1	LM Pattern 1 (LM1): LM Counter Length LM Pattern 1 (LM1): Toggle Position 1 LM Pattern 1 (LM1): Toggle Position 2 LM Pattern 1 (LM1): Special H Pulse Start Position

Table IV. Shutter System Register Map (Addr 0x16)

Addr	Bit Breakdown	Bit Width	Default	Register Name	Function
Shut_Reg(0)	(11:0) (23:12) (31:24)	12 12 8		ENDADDRESS STARTADDRESS SHUT_Reg_Addr	Sub Word End Address Sub Word Start Address System Register Address 0x16
Shut_Reg(1)	(11:0) (23:12) (31:24)	12 12 8	80 370	TGTOG1_0 TGTOG2_0 Unused	TG0 Pulse Toggle Position 1 TG0 Pulse Toggle Position 2
Shut_Reg(2)	(11:0) (23:12) (31:24)	12 12 8	490 780	TGTOG1_1 TGTOG2_1 Unused	TG1 Pulse Toggle Position 1 TG1 Pulse Toggle Position 2
Shut_Reg(3)	(11:0) (23:12) (31:24)	12 12 8	540 720	OFDTOG1_0 OFDTOG2_0 Unused	OFD0 Pulse Toggle Position 1 OFD0 Pulse Toggle Position 2
Shut_Reg(4)	(11:0) (23:12) (31:24)	12 12 8	830 860	OFDTOG1_1 OFDTOG2_1 Unused	OFD1 Pulse Toggle Position 1 OFD1 Pulse Toggle Position 2

Table V. Mode_A (Addr 0x17)

Addr	Bit Breakdown	Bit Width	Default	Register Name	Function
Mode_Reg(0)	(11:0) (23:12) (31:24)	12 12 8		ENDADDRESS STARTADDRESS MODE_Reg_Addr	Sub Word End Address Sub Word Start Address Mode Register Address (Mode A = Addr 0x17)
Mode_Reg(1)	(6:0) 7 8 (12:9) 13 (31:14)	7 1 1 4 1 18	0 0 1 0xA 0	TGACTLINE TGPATSEL0 TGPATSEL1 TGMASK OFDPATSEL Unused	TG Active Line TG1A/B Pattern Selector (0 = TG0, 1 = TG1) TG3A/B Pattern Selector (0 = TG0, 1 = TG1) TG Masking Control (1 = Mask) OFD Pattern Selection (0 = OFD0, 1 = OFD1)
Mode_Reg(2)	(11:0) (23:12) (31:24)	12 12 8	831 866	HDTOG1 HDTOG2 Unused	HD Toggle Position 1 HD Toggle Position 2
Mode_Reg(3)	(11:0) (23:12) (31:24)	12 12 8	4095 4095	HDTOG3 HDTOG4 Unused	HD Toggle Position 3 HD Toggle Position 4
Mode_Reg(4)	(11:0) (22:12) (26:23) (30:27) 31	12 11 4 4 1	2339 262 0 4	HDLASTLEN VDLEN VDTOG1 VDTOG2 Unused	HD Last Line Length VD Field Length VD Toggle Position 1 VD Toggle Position 2
Mode_Reg(5)	(11:0) (23:12) (31:24)	12 12 8	1543 1557	CLPOBTOG1 CLPOBTOG2 Unused	CLPOB Toggle Position 1 CLPOB Toggle Position 2
Mode_Reg(6)	(11:0) (23:12) (31:24)	12 12 8	4095 4095	CLPOBTOG3 CLPOBTOG4 Unused	CLPOB Toggle Position 3 CLPOB Toggle Position 4
Mode_Reg(7)	(11:0) (23:12) 24 (31:25)	12 12 1 7	0 869 0	HBLKTOG1 HBLKTOG2 H1TOG12POL Unused	HBLK Toggle Position 1 HBLK Toggle Position 2 H1 Polarity between Toggle Positions 1 and 2
Mode_Reg(8)	(11:0) (23:12) 24 (31:25)	12 12 1 7	4095 4095 0	HBLKTOG3 HBLKTOG4 H1TOG34POL Unused	HBLK Toggle Position 3 HBLK Toggle Position 4 H1 Polarity between Toggle Positions 3 and 4
Mode_Reg(9)	(11:0) (23:12) (31:24)	12 12 8	6 878	PBLKTOG1 PBLKTOG2 Unused	PBLK Toggle Position 1 PBLK Toggle Position 2
Mode_Reg(10)	(11:0) (23:12) (31:24)	12 12 8	4095 4095	PBLKTOG3 PBLKTOG4 Unused	PBLK Toggle Position 3 PBLK Toggle Position 4
Mode_Reg(11)	(10:0) (21:11) (31:22)	11 11 10	255 3	PBLKSTART PBLKSTOP Unused	PBLK Start Position PBLK Stop Position
Mode_Reg(12)	(10:0) (21:11) 22 (31:23)	11 11 1 9	0 1 0	HMASKSTART HMASKSTOP H1MASKPOL Unused	Vertical H Masking Start Position Vertical H Masking Stop Position Masking Polarity for H1 during Vertical Blanking Period
Mode_Reg(13)	(11:0) (23:12) (31:24)	12 12 8	550 4095	LMSTART0 LMSTART1 Unused	LM Counter Start Position 1 LM Counter Start Position 2

Table V. Mode_A (Addr 0x17) (continued)

Addr	Bit Breakdown	Bit Width	Default	Register Name	Function
Mode_Reg(14)	(7:0)	8	1	SCP1	Sequence Change Position 1
	(15:8)	8	0	SCP2	Sequence Change Position 2
	(23:16)	8	0	SCP3	Sequence Change Position 3
	(31:24)	8	0	SCP4	Sequence Change Position 4
Mode_Reg(15)	(11:0)	12	1559	HDLEN0	HD Counter Length Value for Region 0
	(13:12)	2	0	VTPPATSEL0	VTP Pattern Select (0 = VTP0, 1 = VTP1, 2 = VTP2)
	(16:14)	3	0	VTPREP0	VTP Pulse Repetition Number in Region 0
	17	1	0	LMPATSEL0	LM Pattern Select for Region 0 (0 = LM0, 1 = LM1)
	(19:18)	2	0	LMREP0	LM Repetition Number in Region 0
	20	1	0	SPHEN0	Special H-Pattern Enable in Region 0
	21	1	1	CLPOBEN0	CLPOB Enable in Region 0
(31:22)	10		Unused		
Mode_Reg(16)	(11:0)	12	1559	HDLEN1	HD Counter Length Value for Region 1
	(13:12)	2	0	VTPPATSEL1	VTP Pattern Select (0 = VTP0, 1 = VTP1, 2 = VTP2)
	(16:14)	3	2	VTPREP1	VTP Pulse Repetition Number in Region 1
	17	1	0	LMPATSEL1	LM Pattern Select for Region 1 (0 = LM0, 1 = LM1)
	(19:18)	2	3	LMREP1	LM Repetition Number in Region 1
	20	1	1	SPHEN1	Special H-Pattern Enable in Region 1
	21	1	1	CLPOBEN1	CLPOB Enable in Region 1
(31:22)	10		Unused		
Mode_Reg(17)	(11:0)	12	1559	HDLEN2	HD Counter Length Value for Region 2
	(13:12)	2	0	VTPPATSEL2	VTP Pattern Select (0 = VTP0, 1 = VTP1, 2 = VTP2)
	(16:14)	3	2	VTPREP2	VTP Pulse Repetition Number in Region 2
	17	1	0	LMPATSEL2	LM Pattern Select for Region 2 (0 = LM0, 1 = LM1)
	(19:18)	2	3	LMREP2	LM Repetition Number in Region 2
	20	1	1	SPHEN2	Special H-Pattern Enable in Region 2
	21	1	1	CLPOBEN2	CLPOB Enable in Region 2
(31:22)	10		Unused		
Mode_Reg(18)	(11:0)	12	1559	HDLEN3	HD Counter Length Value for Region 3
	(13:12)	2	0	VTPPATSEL3	VTP Pattern Select (0 = VTP0, 1 = VTP1, 2 = VTP2)
	(16:14)	3	2	VTPREP3	VTP Pulse Repetition Number in Region 3
	17	1	0	LMPATSEL3	LM Pattern Select for Region 3 (0 = LM0, 1 = LM1)
	(19:18)	2	3	LMREP3	LM Repetition Number in Region 3
	20	1	1	SPHEN3	Special H-Pattern Enable in Region 3
	21	1	1	CLPOBEN3	CLPOB Enable in Region 3
(31:22)	10		Unused		
Mode_Reg(19)	(11:0)	12	1559	HDLEN4	HD Counter Length Value for Region 4
	(13:12)	2	0	VTPPATSEL4	VTP Pattern Select (0 = VTP0, 1 = VTP1, 2 = VTP2)
	(16:14)	3	2	VTPREP4	VTP Pulse Repetition Number in Region 4
	17	1	0	LMPATSEL4	LM Pattern Select for Region 4 (0 = LM0, 1 = LM1)
	(19:18)	2	3	LMREP4	LM Repetition Number in Region 4
	20	1	1	SPHEN4	Special H-Pattern Enable in Region 4
	21	1	1	CLPOBEN4	CLPOB Enable in Region 4
(31:22)	10		Unused		

Table VI. Mode_B (Addr 0x18)

Addr	Bit Breakdown	Bit Width	Default	Register Name	Function
Mode_Reg(0)	(11:0) (23:12) (31:24)	12 12 8		ENDADDRESS STARTADDRESS MODE_Reg_Addr	Sub Word End Address Sub Word Start Address Mode Register Address (Mode B = Addr 0x18)
Mode_Reg(1)	(6:0) 7 8 (12:9) 13 (31:14)	7 1 1 4 1 18	0 0 1 0x0 1	TGACTLINE TGPATSEL0 TGPATSEL1 TGMASK OFDPATSEL Unused	TG Active Line TG1A/B Pattern Selector (0 = TG0, 1 = TG1) TG3A/B Pattern Selector (0 = TG0, 1 = TG1) TG Masking Control (1 = Mask) OFD Pattern Selection (0 = OFD0, 1 = OFD1)
Mode_Reg(2)	(11:0) (23:12) (31:24)	12 12 8	95 130	HDTOG1 HDTOG2 Unused	HD Toggle Position 1 HD Toggle Position 2
Mode_Reg(3)	(11:0) (23:12) (31:24)	12 12 8	830 865	HDTOG3 HDTOG4 Unused	HD Toggle Position 3 HD Toggle Position 4
Mode_Reg(4)	(11:0) (22:12) (26:23) (30:27) 31	12 11 4 4 1	1559 525 0 4	HDLASTLEN VDLEN VDTOG1 VDTOG2 Unused	HD Last Line Length VD Field Length VD Toggle Position 1 VD Toggle Position 2
Mode_Reg(5)	(11:0) (23:12) (31:24)	12 12 8	808 822	CLPOBTOG1 CLPOBTOG2 Unused	CLPOB Toggle Position 1 CLPOB Toggle Position 2
Mode_Reg(6)	(11:0) (23:12) (31:24)	12 12 8	1543 1557	CLPOBTOG3 CLPOBTOG4 Unused	CLPOB Toggle Position 3 CLPOB Toggle Position 4
Mode_Reg(7)	(11:0) (23:12) 24 (31:25)	12 12 1 7	1 133 1	HBLKTOG1 HBLKTOG2 H1TOG12POL Unused	HBLK Toggle Position 1 HBLK Toggle Position 2 H1 Polarity between Toggle Positions 1 and 2
Mode_Reg(8)	(11:0) (23:12) 24 (31:25)	12 12 1 7	825 868 0	HBLKTOG3 HBLKTOG4 H1TOG34POL Unused	HBLK Toggle Position 3 HBLK Toggle Position 4 H1 Polarity between Toggle Positions 3 and 4
Mode_Reg(9)	(11:0) (23:12) (31:24)	12 12 8	6 143	PBLKTOG1 PBLKTOG2 Unused	PBLK Toggle Position 1 PBLK Toggle Position 2
Mode_Reg(10)	(11:0) (23:12) (31:24)	12 12 8	831 878	PBLKTOG3 PBLKTOG4 Unused	PBLK Toggle Position 3 PBLK Toggle Position 4
Mode_Reg(11)	(10:0) (21:11) (31:22)	11 11 10	510 6	PBLKSTART PBLKSTOP Unused	PBLK Start Position PBLK Stop Position
Mode_Reg(12)	(10:0) (21:11) 22 (31:23)	11 11 1 9	0 1 0	HMASKSTART HMASKSTOP H1MASKPOL Unused	Vertical H Masking Start Position Vertical H Masking Stop Position Masking Polarity for H1 during Vertical Blanking Period
Mode_Reg(13)	(11:0) (23:12) (31:24)	12 12 8	99 830	LMSTART0 LMSTART1 Unused	LM Counter Start Position 1 LM Counter Start Position 2

Table VI. Mode_B (Addr 0x18) (continued)

Addr	Bit Breakdown	Bit Width	Default	Register Name	Function
Mode_Reg(14)	(7:0)	8	1	SCP1	Sequence Change Position 1
	(15:8)	8	0	SCP2	Sequence Change Position 2
	(23:16)	8	0	SCP3	Sequence Change Position 3
	(31:24)	8	0	SCP4	Sequence Change Position 4
Mode_Reg(15)	(11:0)	12	1559	HDLEN0	HD Counter Length Value for Region 0
	(13:12)	2	0	VTPPATSEL0	VTP Pattern Select (0 = VTP0, 1 = VTP1, 2 = VTP2)
	(16:14)	3	0	VTPREP0	VTP Pulse Repetition Number in Region 0
	17	1	0	LMPATSEL0	LM Pattern Select for Region 0 (0 = LM0, 1 = LM1)
	(19:18)	2	0	LMREP0	LM Repetition Number in Region 0
	20	1	0	SPHEN0	Special H-Pattern Enable in Region 0
	21	1	1	CLPOBEN0	CLPOB Enable in Region 0
(31:22)	10		Unused		
Mode_Reg(16)	(11:0)	12	1559	HDLEN1	HD Counter Length Value for Region 1
	(13:12)	2	1	VTPPATSEL1	VTP Pattern Select (0 = VTP0, 1 = VTP1, 2 = VTP2)
	(16:14)	3	1	VTPREP1	VTP Pulse Repetition Number in Region 1
	17	1	1	LMPATSEL1	LM Pattern Select for Region 1 (0 = LM0, 1 = LM1)
	(19:18)	2	1	LMREP1	LM Repetition Number in Region 1
	20	1	0	SPHEN1	Special H-Pattern Enable in Region 1
	21	1	1	CLPOBEN1	CLPOB Enable in Region 1
(31:22)	10		Unused		
Mode_Reg(17)	(11:0)	12	1559	HDLEN2	HD Counter Length Value for Region 2
	(13:12)	2	1	VTPPATSEL2	VTP Pattern Select (0 = VTP0, 1 = VTP1, 2 = VTP2)
	(16:14)	3	1	VTPREP2	VTP Pulse Repetition Number in Region 2
	17	1	1	LMPATSEL2	LM Pattern Select for Region 2 (0 = LM0, 1 = LM1)
	(19:18)	2	1	LMREP2	LM Repetition Number in Region 2
	20	1	0	SPHEN2	Special H-Pattern Enable in Region 2
	21	1	1	CLPOBEN2	CLPOB Enable in Region 2
(31:22)	10		Unused		
Mode_Reg(18)	(11:0)	12	1559	HDLEN3	HD Counter Length Value for Region 3
	(13:12)	2	1	VTPPATSEL3	VTP Pattern Select (0 = VTP0, 1 = VTP1, 2 = VTP2)
	(16:14)	3	1	VTPREP3	VTP Pulse Repetition Number in Region 3
	17	1	1	LMPATSEL3	LM Pattern Select for Region 3 (0 = LM0, 1 = LM1)
	(19:18)	2	1	LMREP3	LM Repetition Number in Region 3
	20	1	0	SPHEN3	Special H-Pattern Enable in Region 3
	21	1	1	CLPOBEN3	CLPOB Enable in Region 3
(31:22)	10		Unused		
Mode_Reg(19)	(11:0)	12	1559	HDLEN4	HD Counter Length Value for Region 4
	(13:12)	2	1	VTPPATSEL4	VTP Pattern Select (0 = VTP0, 1 = VTP1, 2 = VTP2)
	(16:14)	3	1	VTPREP4	VTP Pulse Repetition Number in Region 4
	17	1	1	LMPATSEL4	LM Pattern Select for Region 4 (0 = LM0, 1 = LM1)
	(19:18)	2	1	LMREP4	LM Repetition Number in Region 4
	20	1	0	SPHEN4	Special H-Pattern Enable in Region 4
	21	1	1	CLPOBEN4	CLPOB Enable in Region 4
(31:22)	10		Unused		

AD9937

SERIAL INTERFACE TIMING

All of the internal registers of the AD9937 are accessed through a 3-wire serial interface. The 3-wire interface consists of a clock (SCK), serial load (SLD), and serial data (SDA).

The AD9937 has three different register types that are configured by the 3-wire serial interface pins. As described in Table VII, the three register types are control registers, system registers, and mode registers.

Table VII. Serial Interface Registers

Register	Address	No. of Registers
Control Registers	0x00 to 0x12	24-Bit Register at Each Address. See Table I.
VTP Sequence System Registers	0x14	Fourteen 32-Bit System Registers at Address 0x14. See Table II.
H/LM System Registers	0x15	Ten 32-Bit System Registers at Address 0x15. See Table III.
Shutter System Registers	0x16	Five 32-Bit System Registers at Address 0x16. See Table IV.
Mode_A	0x17	Twenty 32-Bit Mode_A Registers at Address 0x17. See Table V.
Mode_B	0x18	Twenty 32-Bit Mode_B Registers at Address 0x18. See Table VI.

Control Register Serial Interface

The control register 3-wire interface timing requirements are shown in Figure 5. Writing to control registers requires eight bits of address data followed by 24 bits of configuration data between each active low period of SLD for each address. The SLD signal must be kept high for at least one full SCK cycle between successive writes to control registers.

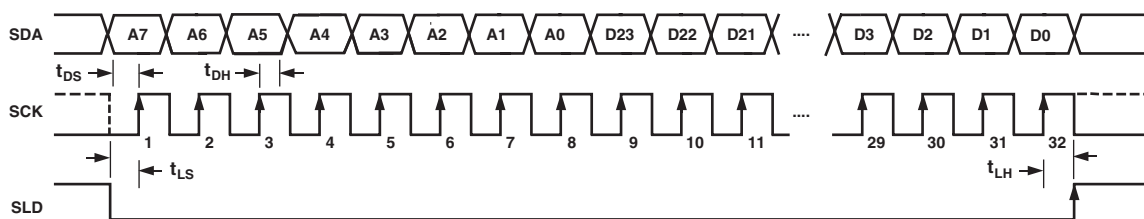

1. SDA BITS ARE INTERNALLY LATCHED ON THE RISING EDGES OF SCK.
2. THIS TIMING PATTERN MUST BE WRITTEN FOR EACH REGISTER WRITE WITH SLD REMAINING HIGH FOR AT LEAST ONE FULL SCK PERIOD BEFORE ASSERTING SLD LOW AGAIN FOR THE NEXT REGISTER WRITE.

Figure 5. 3-Wire Serial Interface Timing for Control Registers

System and Mode Register Serial Interface

The AD9937 provides two options for writing to system and mode registers. The Page/Burst write option is used when all the registers are going to be written to, whereas the Random Access option is used when only one or a small contiguous sequence of registers is going to be written to. As shown in Figure 6, the protocol for writing to system and mode registers requires eight bits for the address data, 12 bits for the start location, 12 bits for the end location, and 32 bits for the register data.

Page/Burst Option

The AD9937 is automatically configured for Page/Burst mode if both 12-bit STARTADDRESS and ENDADDRESS fields equal 0. In this configuration, the AD9937 expects all registers to be written to, therefore all register data must be clocked in before the SLD pulse is asserted high. The SLD pulse is ignored until all register data is clocked in. The Page/Burst option is preferred when initially programming the system and mode registers at startup.

Random Access Option

With the Random Access option, the 12-bit STARTADDRESS and ENDADDRESS fields are typically used when writing to one system or mode register or a small sequential number of system or mode registers. In this mode, the address data selects the system or mode register bank that is going to be accessed, the 12-bit STARTADDRESS determines the first register to be accessed, and the 12-bit ENDADDRESS determines the last register to be accessed. Two examples of Random Access are provided below (refer to Figure 6).

Example 1: Accessing Only One Register, HLM_Reg(6)

```
HLM_Reg_addr[A7:A0] = 0x15
STARTADDRESS[S11:S0] = 0x0006
ENDADDRESS[E11:E0] = 0x0006
```

Example 2: Accessing HLM_Reg(2), HLM_Reg(3), and HLM_Reg(4) Sequentially

```
HLM_Reg_addr[A7:A0] = 0x15
STARTADDRESS[S11:S0] = 0x0002
ENDADDRESS[E11:E0] = 0x0004
```

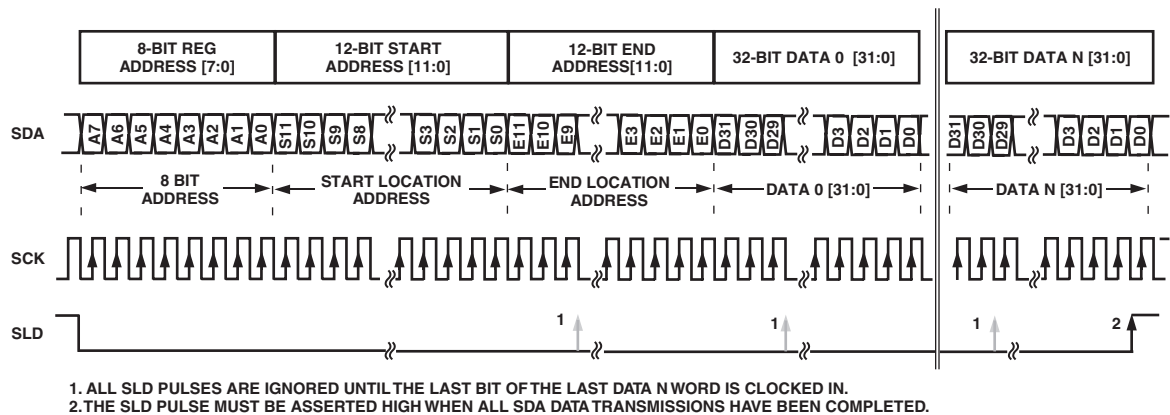

Figure 6. System and Mode Register Writes

Internal Power-On Reset Circuitry

After power-on, the AD9937 automatically resets all internal registers and performs internal calibration procedures. This takes approximately 1 ms to complete. During this time, normal clock signals and serial write operations may occur. However, serial register writes are ignored until the internal reset operation is completed.

VD Synchronous and Asynchronous Register Operation

There are two types of control registers, VD synchronous and VD asynchronous, as indicated in the Address column of Table I. Register writes to synchronous and asynchronous type registers operate differently as described in the following sections. All writes to system, Mode_A, and Mode_B registers occur asynchronously.

Asynchronous Register Operation

For asynchronous register writes, SDA data is stored directly into the serial register at the rising edge of SCK. As a result, register operation begins immediately after the register LSB has been latched in on the rising edge of SCK.

VD Synchronous Register Operation

For VD synchronous type registers, SDA data is temporarily stored in a buffer register upon completion of clocking in the last register LSB. This data is held in the temporary buffer register until the next rising edge of VD is applied. Once the next rising edge of VD occurs, the buffered register data is loaded into the serial register, and register operation begins. See Figure 7.

Control registers at addresses 0x08, 0x09, 0x10, 0x11, and 0x12 are VD synchronous type registers.

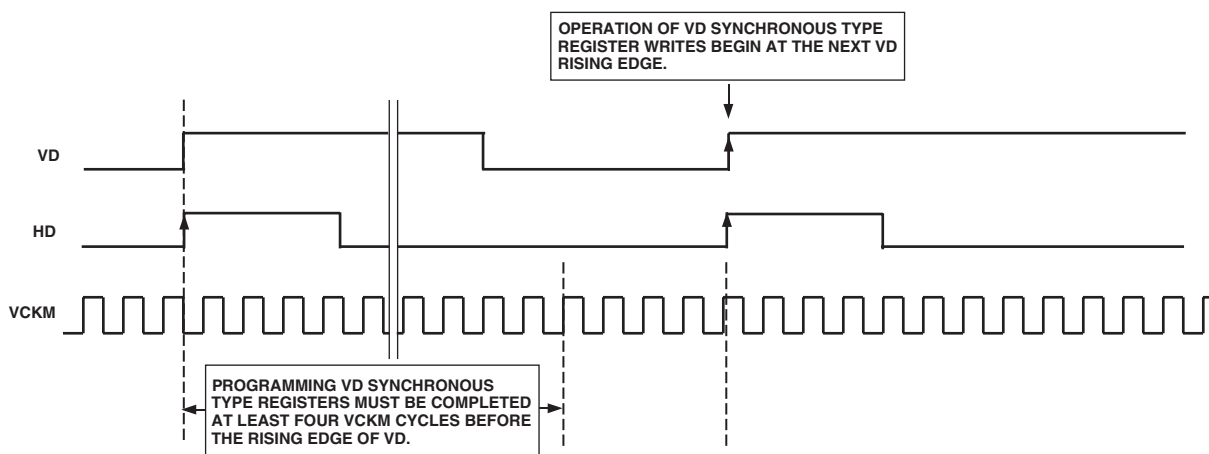

Figure 7. VD Synchronous Type Register Writes

AD9937

SYSTEM OVERVIEW

Figure 8 shows the typical system block diagram for the AD9937. The CCD output is processed by the AD9937's AFE circuitry, which consists of a CDS, VGA, black level clamp, and A/D converter. The digitized pixel information is sent to the digital image processor chip, which performs the postprocessing and compression. To operate the CCD, all CCD timing parameters are programmed into the AD9937 from the system microprocessor, through the 3-wire serial interface. From the system master clock, VCKM provided by the image processor or external crystal, the AD9937 generates all of the CCD's horizontal and vertical clocks and all internal AFE clocks.

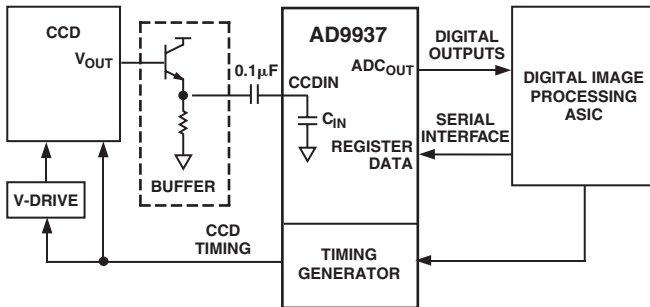

Figure 8. Typical System Block Diagram, Master Mode

The H-drivers for H1(A-D) and H2(A,B), and RS are included in the AD9937, allowing these clocks to be directly connected to the CCD. H-drive voltage of up to 3.6 V is supported. An external V-driver is required for the vertical transfer clocks and sensor gate pulses.

Figure 9 shows the horizontal and vertical counter dimensions for the AD9937. All internal horizontal and vertical clocking is programmed using these dimensions to specify line and pixel locations.

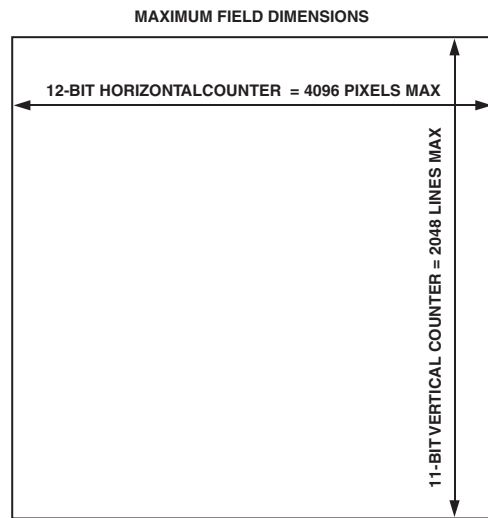

Figure 9. Horizontal and Vertical Counters

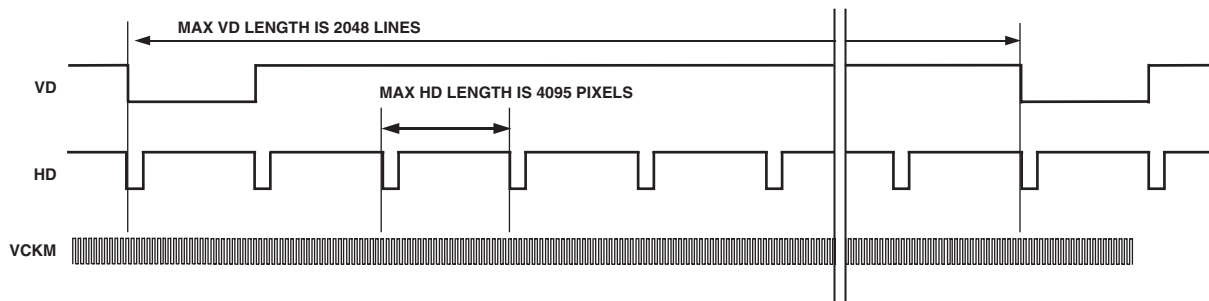

Figure 10. Maximum VD/HD Dimensions

ANALOG FRONT END DESCRIPTION AND OPERATION

The AD9937 AFE signal processing chain is shown in Figure 11. Each processing step is essential in achieving a high quality image from the raw CCD pixel data.

DC Restore

To reduce the large dc offset of the CCD output signal, a dc restore circuit is used with an external $0.1\ \mu\text{F}$ series coupling capacitor. This restores the dc level of the CCD signal to approximately 1.5 V to be compatible with the 3 V analog supply of the AD9937.

Correlated Double Sampler

The CDS circuit samples each CCD pixel twice to extract the video information and reject low frequency noise. The timing diagram in Figure 13 illustrates how the two internally generated CDS clocks, SHP and SHD, are used to sample the reference level and the data level, respectively, of the CCD signal. The placement of the SHP and SHD sampling edges is determined by the setting of the SHPLOC (addr 0x05) and SHDLOC (addr 0x05) control registers. Placement of these two clock edges is critical in achieving the best performance from the CCD.

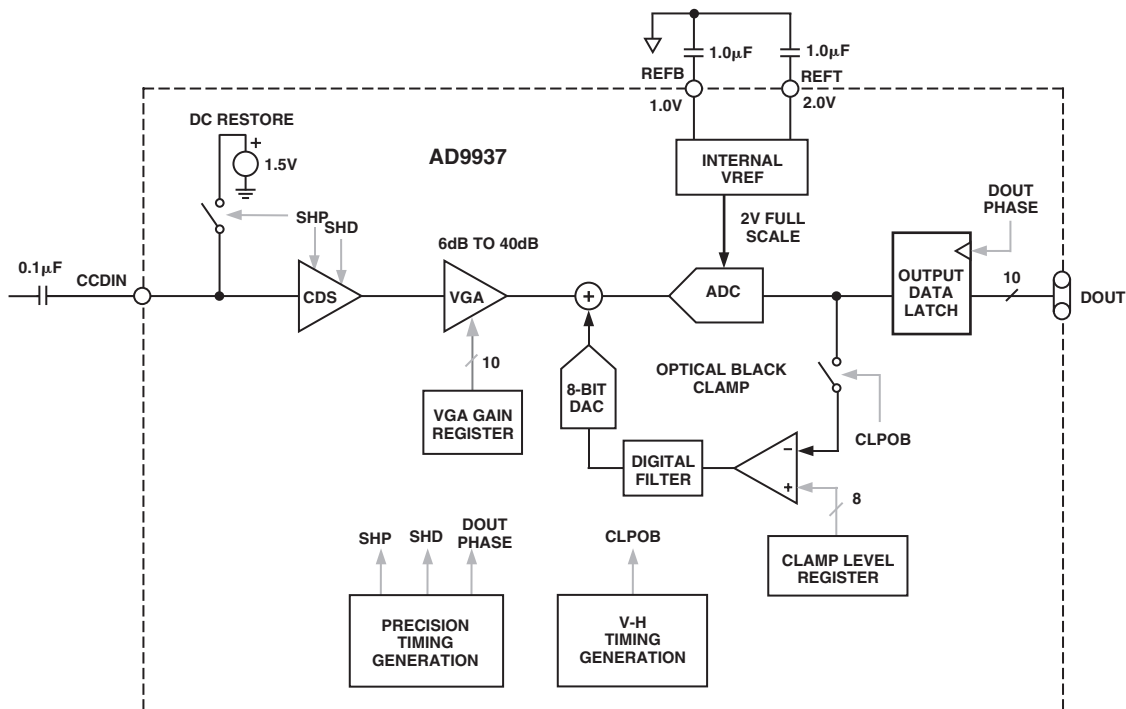

Figure 11. AFE Block Diagram

AD9937

PRECISION TIMING HIGH SPEED TIMING GENERATION

The AD9937 generates flexible high speed timing signals using the precision timing core. This core is the foundation for generating the timing used for both the CCD and the AFE: the reset gate RS, horizontal drivers H1(A–D) and H2(A, B), and the CDS sample clocks. A unique architecture makes it routine for the system designer to optimize image quality by providing precise control over the horizontal CCD readout and the AFE correlated double sampling.

Timing Resolution

The precision timing core uses a 13 master clock input (VCKM) as a reference. This clock should be the same as the CCD pixel clock frequency. Figure 12 illustrates how the internal timing core divides the master clock period into 48 steps or edge positions. Using a 12 MHz VCKM frequency, the edge resolution of the precision timing core is 1.7 ns. A 24 MHz VCKM frequency can be applied to the AD9937 where the AD9937 will internally divide the VCKM frequency by 2. VCKM frequency division by 2 is controlled by using the VCKM_DIVIDE control (addr 0x04) register.

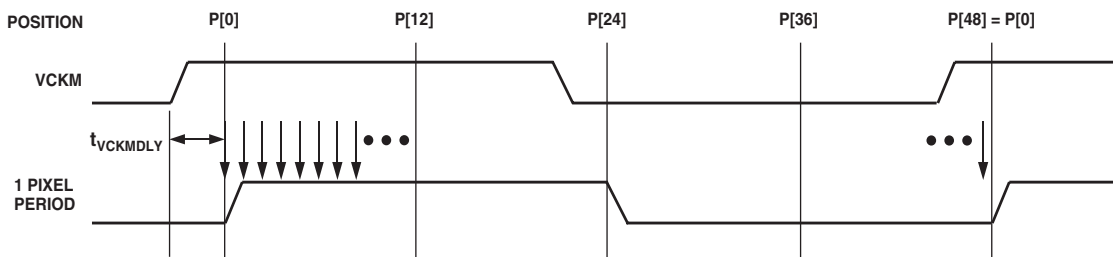

PIXEL CLOCK PERIOD IS DIVIDED INTO 48 POSITIONS, PROVIDING FINE EDGE RESOLUTION FOR HIGH SPEED CLOCKS. THERE IS A FIXED DELAY FROM THE VCKM INPUT TO THE INTERNAL PIXEL PERIOD POSITIONS ($t_{VCKMDLY} = 6\text{ns TYP}$).

Figure 12. High Speed Clock Resolution from VCKM Master Clock

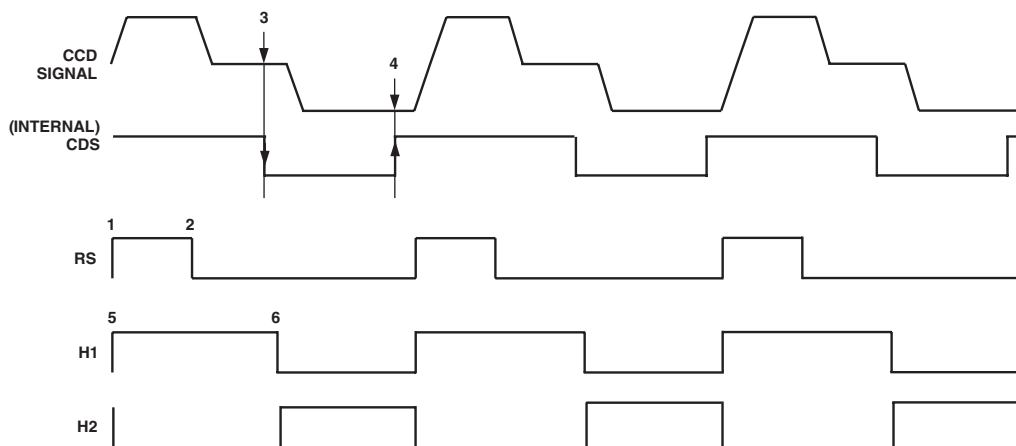

PROGRAMMABLE CLOCK INFORMATION

1. RG RISING EDGE (PROGRAMMABLE AT CONTROL REGISTER RSPOSLOC (ADDR 0x06))
2. RG FALLING EDGE (PROGRAMMABLE AT CONTROL REGISTER RSNEGLOC (ADDR 0x06))
3. SHP SAMPLE LOCATION (PROGRAMMABLE AT CONTROL REGISTER SHPLOC (ADDR 0x05))
4. SHD SAMPLE LOCATION (PROGRAMMABLE AT CONTROL REGISTER SHDLOC (ADDR 0x05))
5. H1 RISING EDGE LOCATION (PROGRAMMABLE AT CONTROL REGISTER H1POSLOC (ADDR 0x06))
6. H1 NEGATIVE EDGE LOCATION (PROGRAMMABLE AT CONTROL REGISTER H1NEGLOC (ADDR 0x06))
7. H2 IS ALWAYS THE INVERSE OF H1.

Figure 13. High Speed Clock Programmable Locations

High Speed Clock Programmability

Figure 13 shows how the high speed clocks RS, H1–H2, SHP, and SHD are generated. The RS and H1 pulse have positive and negative edge programmability by using control registers (addr 0x06). The H2 clock is always the inverse of H1. Table VIII summarizes the high speed timing registers and the parameters for the high speed clocks. Each register is six bits wide with the 2 MSB used to select the quadrant region as outlined in Table IX. Figure 14 shows the range and default locations of the high speed clock signals.

H-Driver and RS Outputs

In addition to the programmable timing positions, the AD9937 features on-chip output drivers for the RS and H1–H2 outputs. These drivers are powerful enough to directly drive the CCD inputs. The H-driver current can be adjusted for optimum rise/fall time into a particular load by using the H1DRV and H2DRV control registers (addr 0x07). The RS drive current is adjustable using the RSDRV control register (addr 0x07). The H1DRV, H2DRV, and RSDRV registers are adjustable in 1.75 mA increments. All DRV registers have setting of 0 equal to OFF or three-state, and the maximum setting of 7.

Table VIII. RS, H1, SHP, SHD, and DOUTPHASE Timing Parameters

Register Name*	Bit Width (Bits)	Register Type	Range	Description
RSPOSLOC	6	Control (Addr 0x06)	0–47 Edge Location	Falling Edge Location for RS
RSNEGLOC	6	Control (Addr 0x06)	0–47 Edge Location	Falling Edge Location for RS
H1POSLOC	6	Control (Addr 0x06)	0–47 Edge Location	Positive Edge Location for H1
H1NEGLOC	6	Control (Addr 0x06)	0–47 Edge Location	Negative Edge Location for H1
SHPLOC	6	Control (Addr 0x05)	0–47 Edge Location	Sample Location for SHP
SHDLOC	6	Control (Addr 0x05)	0–47 Edge Location	Sample Location for SHD
DOUTPHASE	6	Control (Addr 0x05)	0–47 Edge Location	Phase Location of Data Output [9:0]

*The 2 MSB bits are used to select the quadrant.

Table IX. Precision Timing Edge Locations for RS, H1, SHP, SHD, and DOUTPHASE

Signal Name	Quadrant (Range)	RS Rising Edge RSPOSLOC	RS Falling Edge RSNEGLOC
RS	I $P[0] \text{ to } P[11]$	000000 to 001011	000000 to 001011
	II $P[12] \text{ to } P[23]$	010000 to 011011	010000 to 011011
	III $P[24] \text{ to } P[35]$	100000 to 101011	100000 to 101011
	IV $P[36] \text{ to } P[47]$	110000 to 111011	110000 to 111011

Signal Name	Quadrant (Range)	H1 Rising Edge H1POSLOC	H1 Falling Edge H1NEGLOC
H1	I $P[0] \text{ to } P[11]$	000000 to 001011	000000 to 001011
	II $P[12] \text{ to } P[23]$	010000 to 011011	010000 to 011011
	III $P[24] \text{ to } P[35]$	100000 to 101011	100000 to 101011
	IV $P[36] \text{ to } P[47]$	110000 to 111011	110000 to 111011

Signal Name	Quadrant (Range)	CDS (SHP) Rising Edge SHPLOC	CDS (SHD) Falling Edge SHDLOC
CDS (Internal)	I $P[0] \text{ to } P[11]$	000000 to 001011	000000 to 001011
	II $P[12] \text{ to } P[23]$	010000 to 011011	010000 to 011011
	III $P[24] \text{ to } P[35]$	100000 to 101011	100000 to 101011
	IV $P[36] \text{ to } P[47]$	110000 to 111011	110000 to 111011

Signal Name	Quadrant (Range)	DOUT Rising Edge DOUTPHASE	DOUT Falling Edge (Not Programmable)
Data Output[9:0]	I $P[0] \text{ to } P[11]$	000000 to 001011	DOUTPHASE + 24 Steps
	II $P[12] \text{ to } P[23]$	010000 to 011011	DOUTPHASE + 24 Steps
	III $P[24] \text{ to } P[35]$	100000 to 101011	DOUTPHASE + 24 Steps
	IV $P[36] \text{ to } P[47]$	110000 to 111011	DOUTPHASE + 24 Steps

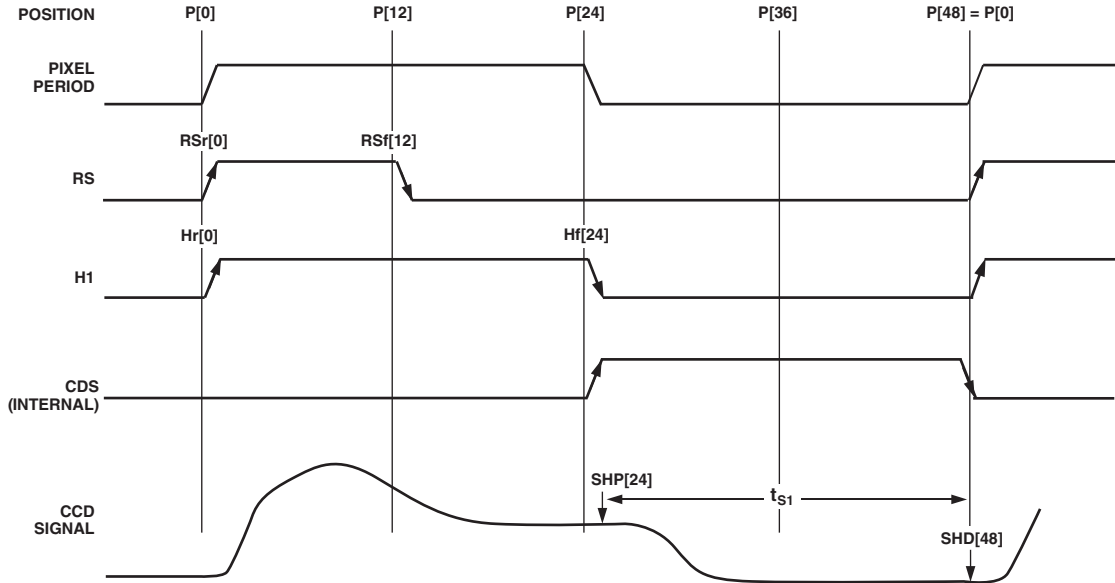

Figure 14. High Speed Clock Default and Programmable Locations

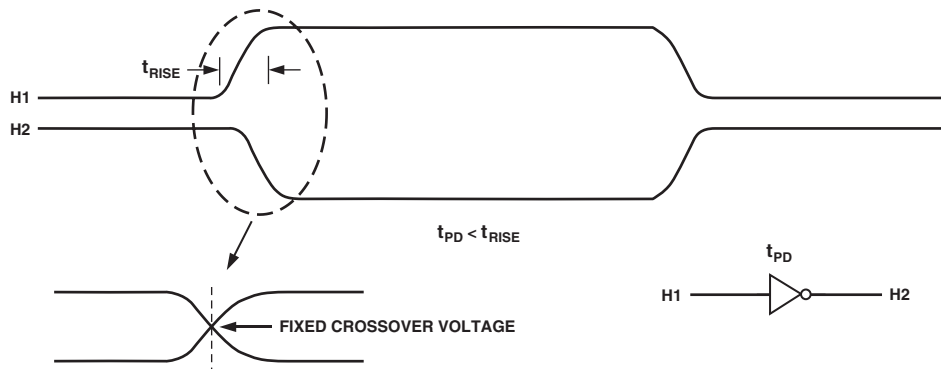
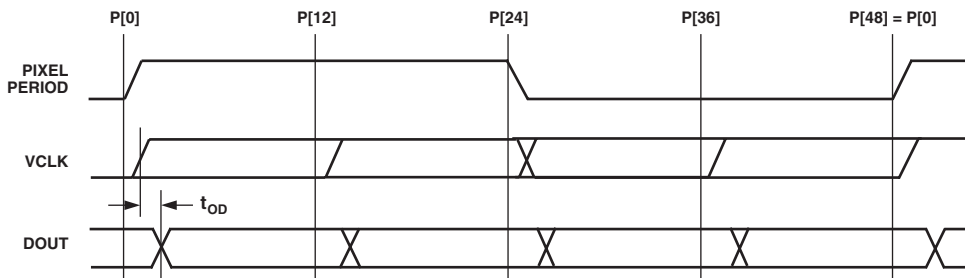

Figure 15. H-Clock Inverse Phase Relationship



1. DOUTPHASE REGISTER (ADDR 0x05) CAN BE USED TO SHIFT THE PHASE OF VCLK AND DOUT TOGETHER WITH RESPECT TO P[0].
2. DOUT[9:0] CAN BE INDEPENDENTLY DELAYED WITH RESPECT TO VCLK BY USING DOUT_DELAY REGISTER (ADDR 0x05).

Figure 16. Digital Output Phase Adjustment

MASTER AND SLAVE MODE OPERATION

The AD9937 defaults at power up into slave mode operation. During slave mode operation, the VD and HD pins are configured as inputs for external VD and HD signals. The AD9937 can be configured into master mode operation to output the VD and HD signals by programming MASTER = 1 (control addr 0x05).

HORIZONTAL AND VERTICAL TIMING

The internal VD and HD synchronization timing is configured by using the registers in Table X. As shown in Figure 17, the HD and VD clock positions are referenced to the 12-bit H-counter and 11-bit V-counter, respectively. This allows for a maximum of 4096 horizontal pixels by 2048 vertical line resolution.

The AD9937 provides programmability for two HD pulses per line with the ability to independently set the last line length by using the HDLASTLEN register (Mode_Reg(4)). Additionally, the HDLENx (where x = 0, 1, 2, 3, 4 representing CCD regions) registers can be used to set different line lengths for each CCD region. As shown in Figure 31, up to five unique CCD regions may be specified.

Individual HMASK Sequence

The HMASK programmable timing shown in Figure 18 provides two HMASK toggle positions and an H1MASK polarity setting. These registers can be used to disable the horizontal H1 and H2 outputs during the vertical transfer period. As shown in Figure 18, the H2(A, B) outputs are always the opposite polarity of the H1(A–D) outputs. The H1MASKSTART and H1MASKSTOP registers reference the 11-bit VD counter.

Individual PBLK Sequences

Up to two individual PBLK pulses can be programmed per line using the registers in Table XI. During the time PBLK is active, the DOUT[9:0] data is fixed at the level set in the PBLK_LEVEL (control addr 0x03) register. Figures 19, 20, and 21 provide examples of PBLK registers described in Table XI.

Table X. HD and VD Registers

Register Name	Length (Bits)	Register Type	Range	Description
VDLEN	11	Mode_Reg(4)	0–2047 Line Number	11-Bit VD Counter Length
VDTOG1	4	Mode_Reg(4)	0–15 Pixel Location	VD Toggle Position 1. See Figure 17.
VDTOG2	4	Mode_Reg(4)	0–15 Pixel Location	VD Toggle Position 2. See Figure 17.
HDTOG1	12	Mode_Reg(2)	0–4095 Pixel Location	HD Toggle Position 1. See Figure 17.
HDTOG2	12	Mode_Reg(2)	0–4095 Pixel Location	HD Toggle Position 2. See Figure 17.
HDTOG3	12	Mode_Reg(3)	0–4095 Pixel Location	HD Toggle Position 3. See Figure 17.
HDTOG4	12	Mode_Reg(3)	0–4095 Pixel Location	HD Toggle Position 4. See Figure 17.
HDLASTLEN	12	Mode_Reg(4)	0–4095 Pixel Location	HD Last Line Length. See Figure 17.
HDLEN0	12	Mode_Reg(15)	0–4095 Pixel Location	12-Bit HD Counter Length Value for CCD Region 0
HDLEN1	12	Mode_Reg(16)	0–4095 Pixel Location	12-Bit HD Counter Length Value for CCD Region 1
HDLEN2	12	Mode_Reg(17)	0–4095 Pixel Location	12-Bit HD Counter Length Value for CCD Region 2
HDLEN3	12	Mode_Reg(18)	0–4095 Pixel Location	12-Bit HD Counter Length Value for CCD Region 3
HDLEN4	12	Mode_Reg(19)	0–4095 Pixel Location	12-Bit HD Counter Length Value for CCD Region 4
VDHD_INVERT	1	Control 0x04	HIGH/LOW	VD and HD Inversion Control

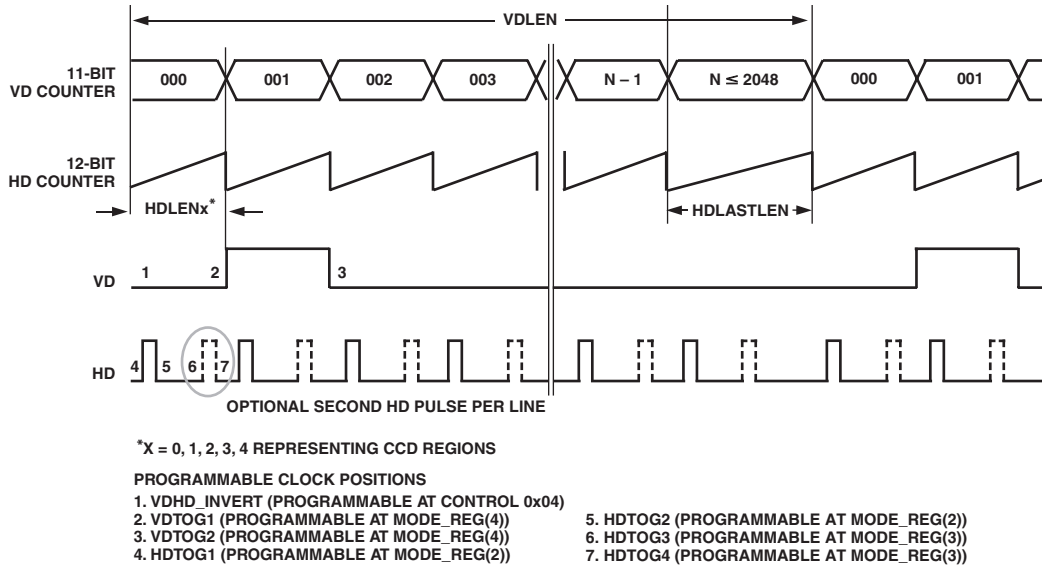

Figure 17. VD and HD Programmable Locations

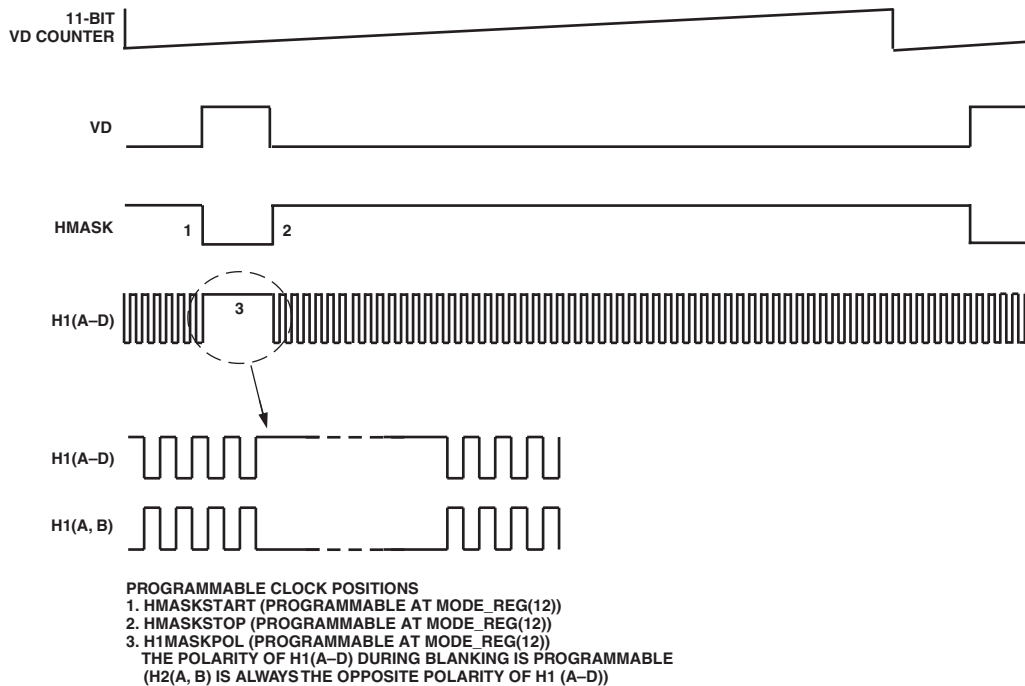
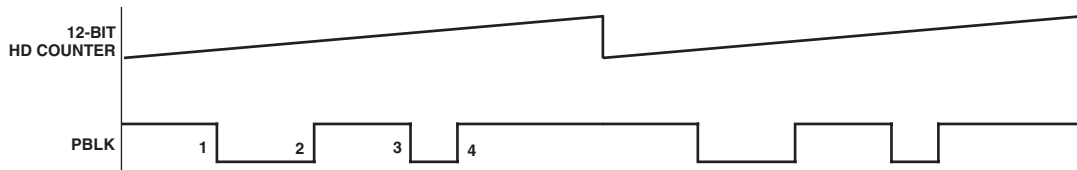

Figure 18. Programmable Clock Positions for HMASK

Table XI. PBLK Registers

Register Name	Length (Bits)	Register Type	Range	Description
PBLK_LEVEL	1	Control 0x03	HIGH/LOW	0 = Blank Output Data to Zero, 1 = Blank Output Data to REFBLACK
PBLKTOG1	12	Mode_Reg(9)	0-4095 Pixel Locations	Sets PBLK Toggle Position 1 within the Line
PBLKTOG2	12	Mode_Reg(9)	0-4095 Pixel Locations	Sets PBLK Toggle Position 2 within the Line
PBLKTOG3	12	Mode_Reg(10)	0-4095 Pixel Locations	Sets PBLK Toggle Position 3 within the Line
PBLKTOG4	12	Mode_Reg(10)	0-4095 Pixel Locations	Sets PBLK Toggle Position 4 within the Line
PBLKSTART	11	Mode_Reg(11)	0-2047 Line Number	Sets the Line Number the PBLK Pulse Will Start In
PBLKSTOP	11	Mode_Reg(11)	0-2047 Line Number	Sets the Line Number the PBLK Pulse Will Stop In



- PROGRAMMABLE CLOCK POSITIONS
1. PBLKTOG1 (PROGRAMMABLE AT MODE_REG(9))
 2. PBLKTOG2 (PROGRAMMABLE AT MODE_REG(9))
 3. PBLKTOG3 (PROGRAMMABLE AT MODE_REG(10))
 4. PBLKTOG4 (PROGRAMMABLE AT MODE_REG(10))

Figure 19. PBLK Timing

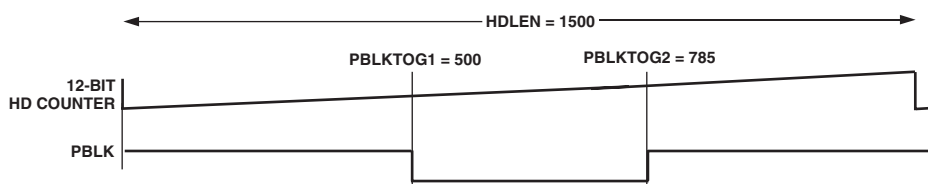

1. PBLKTOG1 = 500
2. PBLKTOG2 = 785
3. PBLKTOG3 = 4095
4. PBLKTOG4 = 4095
5. THIS PBLK PULSE SEQUENCE IS USED IN THE EXAMPLE BELOW.

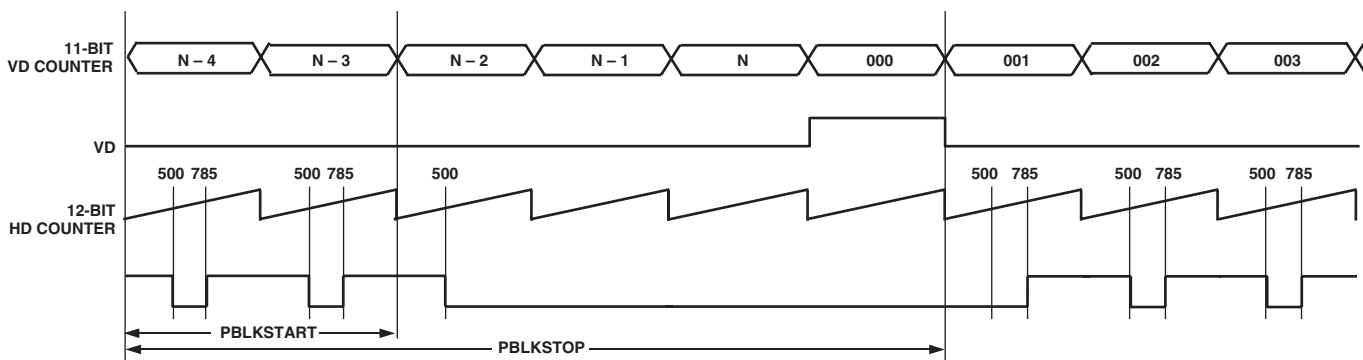

1. PBLKSTART = N - 2
2. PBLKSTOP = 001
3. THIS EXAMPLE SHOWS HOW PBLK IS LOW IN THE VERTICAL BLANKING REGION FROM PBLKTOG1 IN LINE PBLKSTART UNTIL PBLKTOG2 IN LINE PBLKSTOP. AS SHOWN IN THE ABOVE FIGURE, PBLK REMAINS LOW FROM PBLKTOG1 TO PBLKTOG2.

Figure 20. Example of PBLK Applied in Vertical Blanking Region Using PBLKSTART and PBLKSTOP Registers

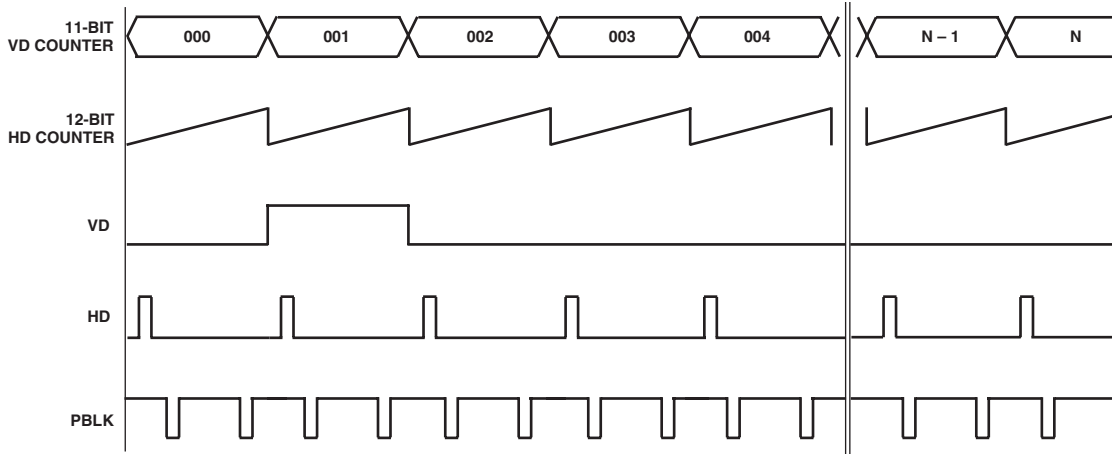

Figure 21. Example with PBLKSTOP = PBLKSTART = 2048

Controlling CLPOB Clamp Pulse Timing

Up to two individual CLPOB pulses can be programmed per line using the CLPOBTOG_x (x = 1, 2, 3, 4) registers in Table XII. As shown in Figure 19, these registers reference the 12-bit HD counter. Additional CLPOBEN_n (n = 0, 1, 2, 3, 4) registers are

provided that allow for independently enabling and disabling the CLPOB pulse in each region of the CCD. Figure 23 shows an example of disabling the CLPOB pulse while operating in CCD region 1.

Table XII. CLPOB Registers

Register Name	Length (Bits)	Register Type	Range	Description
CLPOBTOG1	12	Mode_Reg(5)	0–4095 Pixel Location	First Toggle Position for CLPOB
CLPOBTOG2	12	Mode_Reg(5)	0–4095 Pixel Location	First Toggle Position for CLPOB
CLPOBTOG3	12	Mode_Reg(6)	0–4095 Pixel Location	First Toggle Position for CLPOB
CLPOBTOG4	12	Mode_Reg(6)	0–4095 Pixel Location	First Toggle Position for CLPOB
CLPOBEN0	1	Mode_Reg(15)	Enabled/Disabled	CCD Region 0 CLPOB Enable Disable Control
CLPOBEN1	1	Mode_Reg(16)	Enabled/Disabled	CCD Region 1 CLPOB Enable Disable Control
CLPOBEN2	1	Mode_Reg(17)	Enabled/Disabled	CCD Region 2 CLPOB Enable Disable Control
CLPOBEN3	1	Mode_Reg(18)	Enabled/Disabled	CCD Region 3 CLPOB Enable Disable Control
CLPOBEN4	1	Mode_Reg(19)	Enabled/Disabled	CCD Region 4 CLPOB Enable Disable Control

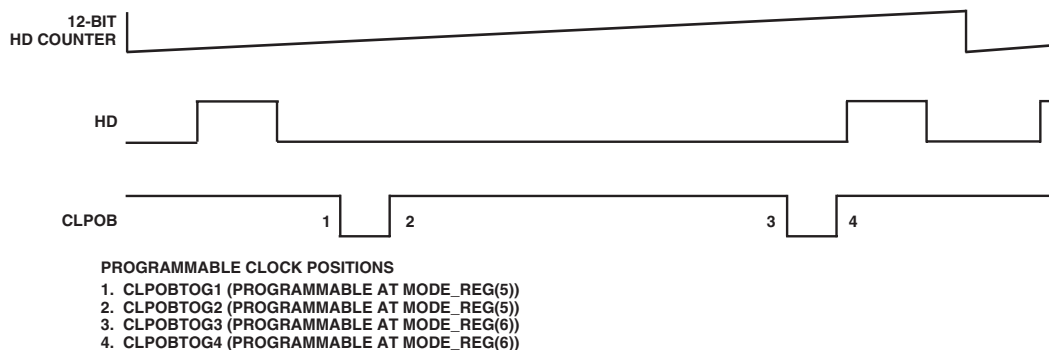

Figure 22. CLPOB Toggle Positions

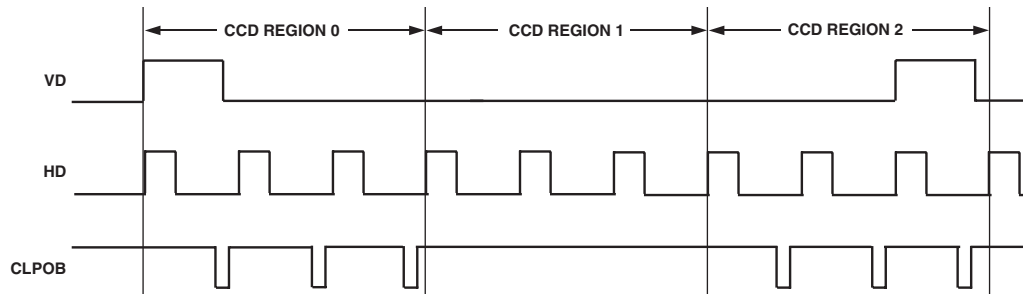

Figure 23. Example with CLPOBEN1 = 0

Vertical Sensor Transfer Gate Timing

The vertical transfer sensor gate (TG) pulses are used to transfer the pixel charges from the light-sensitive image area into the light-shielded vertical registers. When a mechanical shutter is not being used, this transfer effectively ends the exposure period during the image acquisition. From the light-shield vertical registers, the image is then read out line by line using the vertical transfer pulses in conjunction with the high speed horizontal clocks.

The AD9937 provides four programmable vertical transfer gate pulses (TG1A, TG1B, TG3A, and TG3B). Table XIII lists the TG registers. Two unique TG pulses can be preprogrammed using the TGTOG_x (x = 0, 1) registers. As shown in Figure 24, these toggle registers reference the 12-bit H counter for resolution control at the pixel level. Once the toggle positions have been programmed, the TGPATSELx (x = 0, 1) can be used to select which of the two TG pulses will be output on the TG1A/B and TG3A/B pins. The TG1A/B and TG3A/B outputs are selected as a group. As a result, the TG1A and TG1B outputs will always be the same. This also applies for the TG3A and TG3B outputs. For example, if TGPATSEL0 = 0, TG1A and TG1B will have the outputs provided by the TGTOG1_0 and TGTOG2_0 registers.

The TGMASK register can be used to individually mask (disable) any one of the TG outputs. For example, if TGMASK = 1, the TG1A will not be output. All TG outputs can be disabled by setting TGEN = 0.

SHUTTER TIMING CONTROL

CCD image exposure is controlled through use of the substrate clock signal (OFD), which pulses the CCD substrate to clear out accumulated charge. The AD9937 supports two types of OFD shutter timing: normal shutter mode and high precision shutter mode. The registers used for OFD programming are described in Table XIV.

Normal Shutter Mode

Figure 24 shows the VD and OFD output for normal shutter mode. Programming the OFD outputs is similar to programming the TG pulse whereas two unique OFD pulses can be preprogrammed using the OFDTOG_x (x = 0, 1) registers. The OFDTOG_x registers reference the 12-bit HD counter as shown in Figure 24. Once the toggle positions have been programmed, the OFDPATSEL register is used to select which of the two preprogrammed OFD pulses will be output. The OFD will pulse once per line for as many lines set in the OFDNUM register.

High Precision Shutter Mode

High precision shuttering is controlled in the same way as normal shuttering but requires a second set of shutter registers. In this mode, the OFD still pulses once per line, but the last OFD in the field will have an additional OFD pulse whose location is determined by the OFDHPTOG1 and OFDHPTOG2 registers. An example of this is shown in Figure 25. Finer resolution of the exposure time is possible using this mode. Leaving both OFDHPTOG registers set to 4095 disables the high precision shutter mode (default setting).

Table XIII. TG Registers

Register Name	Length (Bits)	Register Type	Range	Description
TGEN	1	Control 0x10	High/Low	TG Output Enable Control (0 = Disable, 1 = Enable)
TGTOG1_0	12	Shut_Reg(1)	0–4095 Pixel Location	TG0 Pulse Toggle Position 1
TGTOG2_0	12	Shut_Reg(1)	0–4095 Pixel Location	TG0 Pulse Toggle Position 2
TGTOG1_1	12	Shut_Reg(2)	0–4095 Pixel Location	TG1 Pulse Toggle Position 1
TGTOG2_1	12	Shut_Reg(2)	0–4095 Pixel Location	TG1 Pulse Toggle Position 2
TGACTLINE	7	Mode_Reg(1)	0–127 Pixel Location	Line in Field where TG Outputs are Active
TGPATSEL0	1	Mode_Reg(1)	High/Low	TG1 A/B Pattern Selector (0 = TG0, 1 = TG1)
TGPATSEL1	1	Mode_Reg(1)	High/Low	TG3 A/B Pattern Selector (0 = TG0, 1 = TG1)
TGMASK	4	Mode_Reg(1)	4 Individual Bits	TG Masking Control (0 = No Masking, 1 = Mask TG1A, 2 = Mask TG1B, 3 = Mask TG3A, 4 = Mask TG3B)

Table XIV. OFD Registers

Register Name	Length (Bits)	Register Type	Range	Description
OFDEN	1	Control 0x10	High/Low	OFD Output Enable Control (0 = Disable, 1 = Enable)
OFDNUM	11	Control 0x10	0–2048 Pulses	Total Number of OFD Pulses per Field
OFDHPTOG1	12	Control 0x11	0–4095 Pixel Locations	High Precision Toggle Position 1. See Figure 24.
OFDHPTOG2	12	Control 0x11	0–4095 Pixel Locations	High Precision Toggle Position 2. See Figure 24.
OFDTOG1_0	12	Shut_Reg(3)	0–4095 Pixel Locations	OFD0 Pulse Toggle Position 1
OFDTOG2_0	12	Shut_Reg(3)	0–4095 Pixel Locations	OFD0 Pulse Toggle Position 2
OFDTOG1_1	12	Shut_Reg(4)	0–4095 Pixel Locations	OFD1 Pulse Toggle Position 1
OFDTOG2_1	12	Shut_Reg(4)	0–4095 Pixel Locations	OFD1 Pulse Toggle Position 2
OFDPATSEL	1	Mode_Reg(1)	High/Low	OFD Pattern Selector (0 = OFD0, 1 = OFD1)

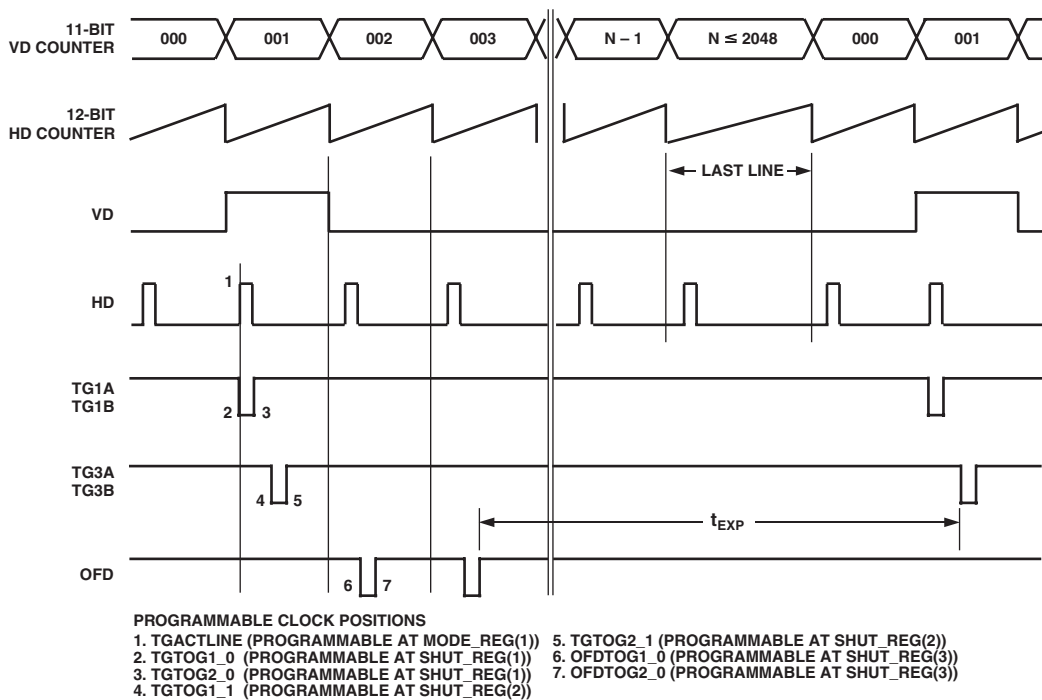

Figure 24. Horizontal Timing Example with TGACTION = 1 and OFDNUM = 2

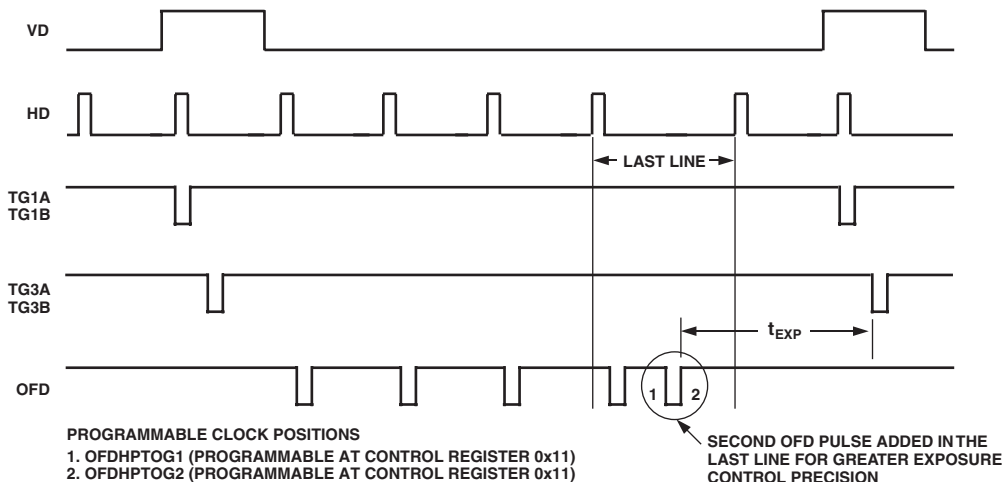

Figure 25. High Precision

Controlling LM Pulse Timing

The AD9937 provides an LM output pulse that is fully programmable by using the registers in Table XV. Two unique sets of LM pulses can be preprogrammed using the LMLEN_x, LMTOG1_x, and LMTOG2_x (x = 0, 1) registers. Once these pulses are preprogrammed, they can be individually selected to be output in any of the five CCD regions by using the LMPATSEL_n register (n = 0, 1, 2, 3, 4). The number of repetitions can also be individually programmed for each CCD region by using the LMREP_n register (n = 0, 1, 2, 3, 4).

The 12-bit H counter and 8-bit LM counters are used for configuring the LM pulse. The 8-bit LM counter resets to 0 when

the 12-bit H counter resets to 0 set by the HDLEN register. The LMSTART0 and LMSTART1 positions reference the 12-bit H counter value zero. The 8-bit LM counter begins counting when LMSTART0 is reached; it counts up to the value set in the LMLEN_x register, as shown in Figure 26. The LM pulse toggle positions reference the 8-bit LM counter.

Figures 26 and 27 provide examples of programming the LM pulses. Figure 26 shows an example when LMSTART1 is less than HDLEN. In this case, multiple sets of LM pulses can be output between the HDLEN lengths. The number of sets is determined by the value of HDLEN and LMSTART1. Figure 27 shows that only one set of LM pulses will be output when LMSTART1 is greater than HDLEN.

Table XV. LM Registers

Register Name	Length (Bits)	Register Type	Range	Description
LM_INVERT	1	Control 0x04	High/Low	LM Inversion Control (1 = Invert Programmed LM)
LMSTART0*	12	Mode_Reg(13)	0–4095 Pixels	LM Counter Start Position 1
LMSTART1*	12	Mode_Reg(13)	0–4095 Pixels	LM Counter Start Position 2
LMLEN0	8	HLM_Reg(8)	0–255 Pixels	LM Counter Length for LM0
LMTOG1_0	8	HLM_Reg(8)	0–255 Pixels	LM0 Toggle Position 1
LMTOG2_0	8	HLM_Reg(8)	0–255 Pixels	LM0 Toggle Position 2
LMLEN1	8	HLM_Reg(9)	0–255 Pixels	LM Counter Length for LM1
LMTOG1_1	8	HLM_Reg(9)	0–255 Pixels	LM1 Toggle Position 1
LMTOG2_1	8	HLM_Reg(9)	0–255 Pixels	LM1 Toggle Position 2
LMPATSEL0	1	Mode_Reg(15)	High/Low	Selects CCD Region 0 LM Pattern (0 = LM0, 1 = LM1)
LMREP0	2	Mode_Reg(15)	0–3 LM Repetitions	LM Repetition Number in CCD Region 0
LMPATSEL1	1	Mode_Reg(16)	High/Low	Selects CCD Region 1 LM Pattern (0 = LM0, 1 = LM1)
LMREP1	2	Mode_Reg(16)	0–3 LM Repetitions	LM Repetition Number in CCD Region 1
LMPATSEL2	1	Mode_Reg(17)	High/Low	Selects CCD Region 2 LM Pattern (0 = LM0, 1 = LM1)
LMREP2	2	Mode_Reg(17)	0–3 LM Repetitions	LM Repetition Number in CCD Region 2
LMPATSEL3	1	Mode_Reg(18)	High/Low	Selects CCD Region 3 LM Pattern (0 = LM0, 1 = LM1)
LMREP3	2	Mode_Reg(18)	0–3 LM Repetitions	LM Repetition Number in CCD Region 3
LMPATSEL4	1	Mode_Reg(19)	High/Low	Selects CCD Region 4 LM Pattern (0 = LM0, 1 = LM1)
LMREP4	2	Mode_Reg(19)	0–3 LM Repetitions	LM Repetition Number in CCD Region 4

*LMSTART0 and LMSTART1 reference the 12-bit HD counter.

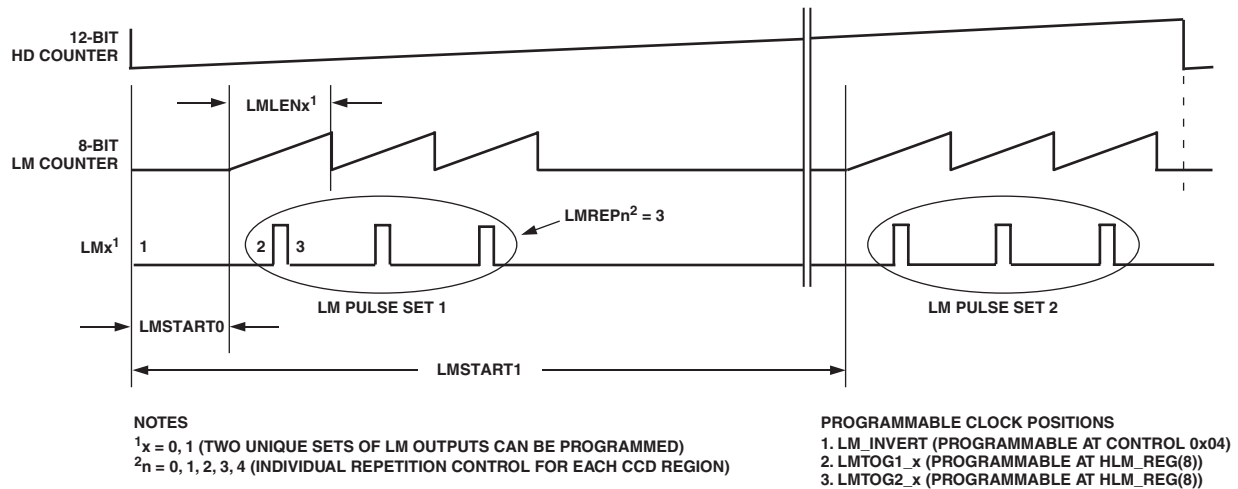

Figure 26. Example of LM Pulse with LMSTART1 < HDLEN

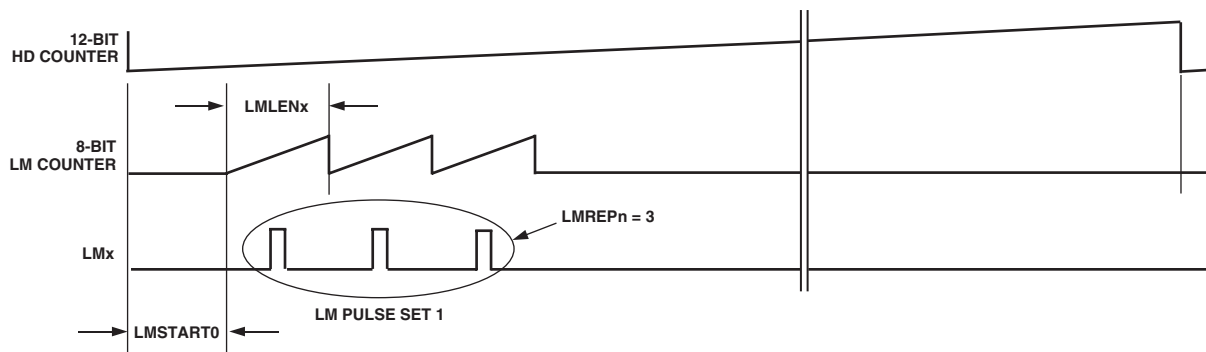

Figure 27. Example of LM Pulse with LMSTART1 > HDLEN

SPECIAL HORIZONTAL PATTERN TIMING

The AD9937 provides the ability to interrupt the normal horizontal H1(A–D) and H2(A, B) clocking in order to apply a special pattern on these outputs. This special horizontal pattern timing occurs during the period when the LM outputs are active. Table XVI lists the registers used to program the special H patterns. Figure 28 provides an example of a special H pattern being applied to the H1A output.

The timing diagram shown in Figure 28 identifies the registers associated with outputting the special H patterns. Although only

the H1A output is shown, the same special H timing can be independently configured on the remaining horizontal outputs by using the registers described in Table XVI. As shown in Figure 28, the special H1A output begins when SPHSTARTx is reached. It is important to note that there are two SPHSTART registers. If SPHPATSEL = 0, the SPHSTART0 register will be used, whereas if SPHPATSEL = 1, the SPHSTART1 register will be used. The special H patterns can be enabled and disabled for each of the five CCD regions by using the SPHENx (x = 0, 1, 2, 3, 4).

MASKING H1 AND H2 OUTPUTS

The H1 and H2 outputs can be masked during the horizontal and vertical transfers as shown in Figures 29 and 30.

Horizontal Masking

The H1 clocks are masked with the polarity set by the H1MASKPOL register as shown in Figure 29. The H2 outputs will always be the opposite polarity of H1. The H1 and H2 outputs are masked from HDLEN + 1 to HBLKTOG1 position when HDLASTLEN is the same as HDLEN. In the case when HDLASTLEN is greater than HDLEN, the H1 and H2 outputs

will be masked during the entire last line. It is recommended to always program HBLKTOG3 and HBLKTOG4 to 4095 when only one H-blanking in a line is required. It is also recommended to program HBLKTOG1 < HBLKTOG2 < HBLKTOG3 < HBLKTOG4.

Vertical Masking

As shown in Figure 30, the H1 and H2 outputs remain masked if the horizontal HMASK is followed by the vertical HMASK region or if the vertical HMASK region is followed by the horizontal HMASK region.

Table XVI. Special H Pattern Registers

Register Name	Length (Bits)	Register Type	Range	Description
HBLKTOG1 ¹	12	Mode_Reg(7)	0–4095 Pixel Locations	HBLK Toggle Position 1
HBLKTOG2 ¹	12	Mode_Reg(7)	0–4095 Pixel Locations	HBLK Toggle Position 2
HBLKTOG3 ¹	12	Mode_Reg(8)	0–4095 Pixel Locations	HBLK Toggle Position 3
HBLKTOG4 ¹	12	Mode_Reg(8)	0–4095 Pixel Locations	HBLK Toggle Position 4
H1APOL	1	HLM_Reg(1)	High/Low	H1A Special H Pattern Start Polarity
H1BPOL	1	HLM_Reg(1)	High/Low	H1B Special H Pattern Start Polarity
H1CPOL	1	HLM_Reg(1)	High/Low	H1C Special H Pattern Start Polarity
H1DPOL	1	HLM_Reg(1)	High/Low	H1D Special H Pattern Start Polarity
H2APOL	1	HLM_Reg(1)	High/Low	H2A Special H Pattern Start Polarity
H2BPOL	1	HLM_Reg(1)	High/Low	H2B Special H Pattern Start Polarity
SPHSTART0 ²	8	HLM_Reg(8)	0–255 Pixel Locations	LM Pattern #0 (LM0) Special H Pulse Start Position
SPHSTART1 ²	8	HLM_Reg(9)	0–255 Pixel Locations	LM Pattern #1 (LM1) Special H Pulse Start Position
SPH1A1	6	HLM_Reg(2)	6 Individual Bits	H1A Special H Pattern during LM Repetition 1
SPH1B1	6	HLM_Reg(2)	6 Individual Bits	H1B Special H Pattern during LM Repetition 1
SPH1C1	6	HLM_Reg(2)	6 Individual Bits	H1C Special H Pattern during LM Repetition 1
SPH1D1	6	HLM_Reg(3)	6 Individual Bits	H1D Special H Pattern during LM Repetition 1
SPH2A1	6	HLM_Reg(3)	6 Individual Bits	H2A Special H Pattern during LM Repetition 1
SPH2B1	6	HLM_Reg(3)	6 Individual Bits	H2B Special H Pattern during LM Repetition 1
SPH1A2	6	HLM_Reg(4)	6 Individual Bits	H1A Special H Pattern during LM Repetition 2
SPH1B2	6	HLM_Reg(4)	6 Individual Bits	H1B Special H Pattern during LM Repetition 2
SPH1C2	6	HLM_Reg(4)	6 Individual Bits	H1C Special H Pattern during LM Repetition 2
SPH1D2	6	HLM_Reg(5)	6 Individual Bits	H1D Special H Pattern during LM Repetition 2
SPH2A2	6	HLM_Reg(5)	6 Individual Bits	H2A Special H Pattern during LM Repetition 2
SPH2B2	6	HLM_Reg(5)	6 Individual Bits	H2B Special H Pattern during LM Repetition 2
SPH1A3	6	HLM_Reg(6)	6 Individual Bits	H1A Special H Pattern during LM Repetition 3
SPH1B3	6	HLM_Reg(6)	6 Individual Bits	H1B Special H Pattern during LM Repetition 3
SPH1C3	6	HLM_Reg(6)	6 Individual Bits	H1C Special H Pattern during LM Repetition 3
SPH1D3	6	HLM_Reg(7)	6 Individual Bits	H1D Special H Pattern during LM Repetition 3
SPH2A3	6	HLM_Reg(7)	6 Individual Bits	H2A Special H Pattern during LM Repetition 3
SPH2B3	6	HLM_Reg(7)	6 Individual Bits	H2B Special H Pattern during LM Repetition 3
SPHEN0	1	Mode_Reg(15)	High/Low	Special H Pattern Enable in CCD Region 0
SPHEN1	1	Mode_Reg(16)	High/Low	Special H Pattern Enable in CCD Region 1
SPHEN2	1	Mode_Reg(17)	High/Low	Special H Pattern Enable in CCD Region 2
SPHEN3	1	Mode_Reg(18)	High/Low	Special H Pattern Enable in CCD Region 3
SPHEN4	1	Mode_Reg(19)	High/Low	Special H Pattern Enable in CCD Region 4

NOTES

¹The HBLKTOGx toggle positions reference the 12-bit HD counter.

²The SPHSTART0 and SPHSTART1 toggle positions reference the 8-bit LM counter.

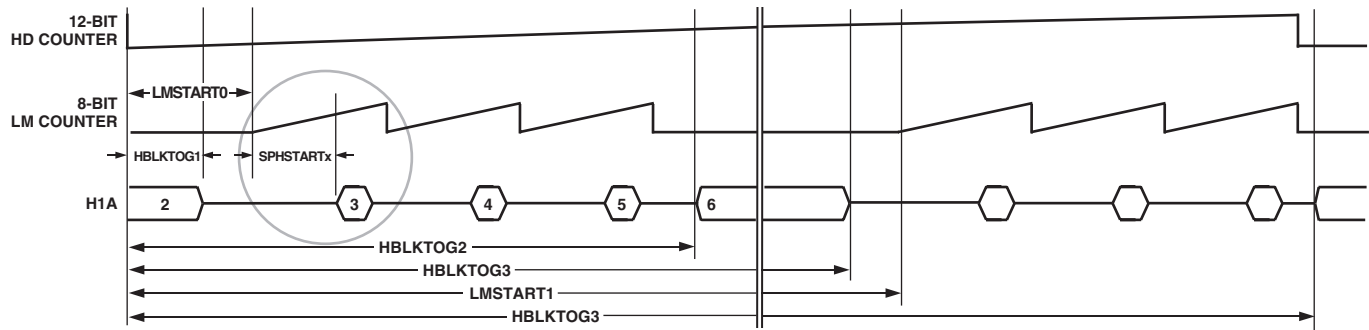

PROGRAMMING NOTES

1. THERE ARE TWO SPHSTART REGISTERS. THEY ARE SPHSTART0 AND SPHSTART1. SPHSTART0 IS USED WHEN THE LM0 PULSE IS SELECTED BY SETTING LMPATSEL = 0. SPHSTART1 IS USED WHEN THE LM1 PULSE IS SELECTED BY SETTING LMPATSEL = 1.
2. THIS REGION REPRESENTS NORMAL H1A OUTPUTS.
3. THIS REGION REPRESENTS SPECIAL H1A PATTERN BEING OUTPUT DURING THE LM REP 1. THE SPH1A1 REGISTER IS USED TO SET THE SPECIAL H1A PATTERN IN THIS REGION.
4. THIS REGION REPRESENTS SPECIAL H1A PATTERN BEING OUTPUT DURING THE LM REP 2. THE SPH1A2 REGISTER IS USED TO SET THE SPECIAL H1A PATTERN IN THIS REGION.
5. THIS REGION REPRESENTS SPECIAL H1A PATTERN BEING OUTPUT DURING THE LM REP 3. THE SPH1A3 REGISTER IS USED TO SET THE SPECIAL H1A PATTERN IN THIS REGION.
6. THIS REGION REPRESENTS NORMAL H1A OUTPUTS.

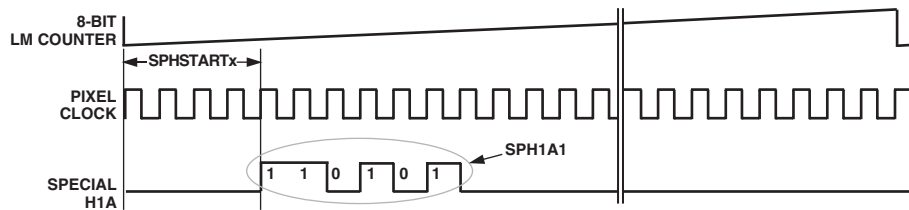

PROGRAMMING NOTES

1. THIS EXAMPLE SHOWS H1A OUTPUT FOR REGION 3 ABOVE. IN THIS EXAMPLE: SPH1A1 = 110101.
2. THE SPECIAL H PATTERN STARTING POLARITY CAN BE INDEPENDENTLY SET FOR EACH H OUTPUT USING THE POL REGISTERS LISTED IN TABLE XVI. NOTE: THE SPECIAL H STARTING POLARITY WILL OCCUR AT THE START OF SPHSTARTx. (ABOVE: H1APOL = 0)

Figure 28. Example of Programming the Special H-Output Patterns

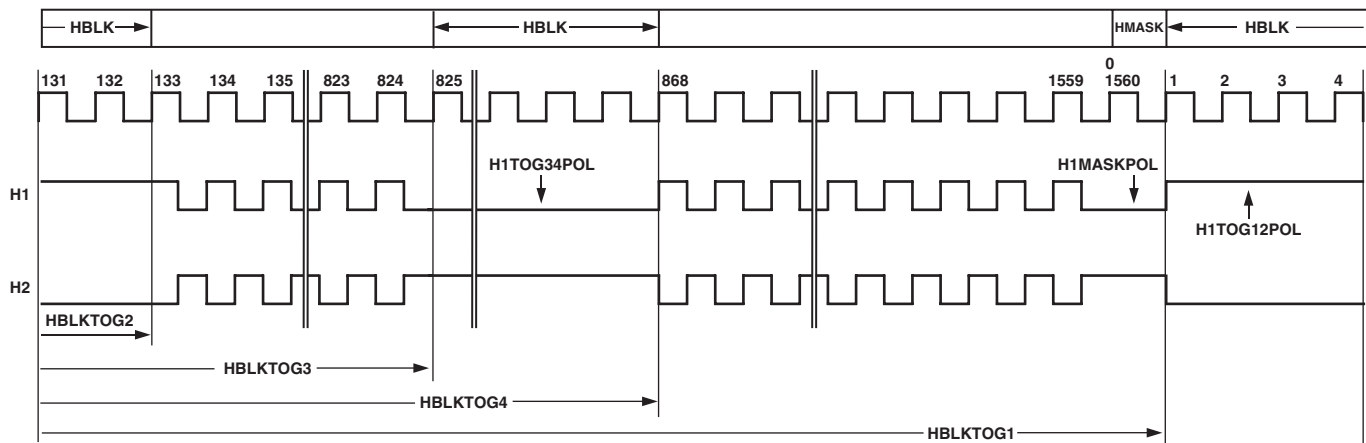

Figure 29. Example of Horizontal HMASK Masking

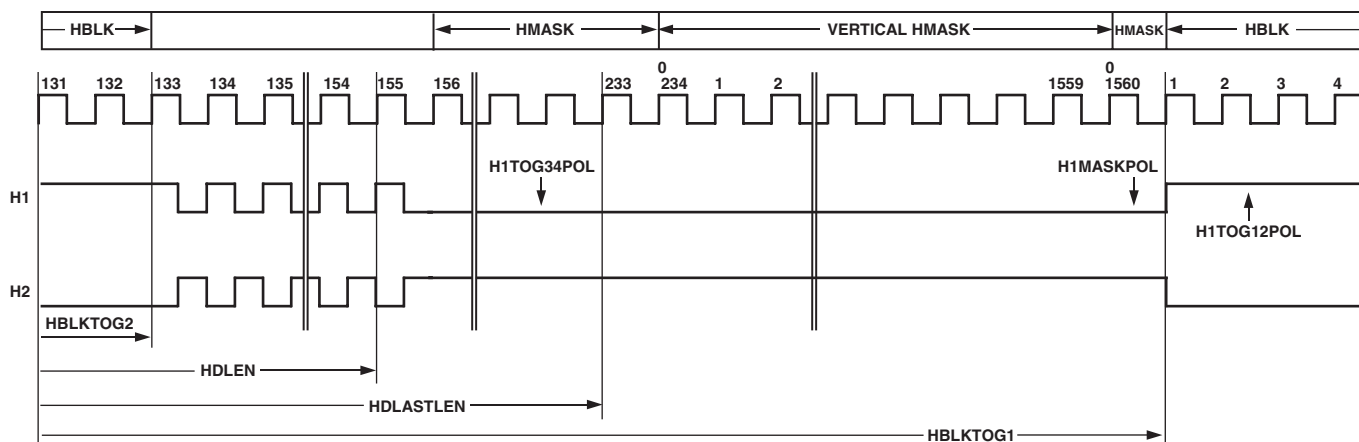

Figure 30. Example of Vertical HMASK Masking with HDLASTLEN > HDLEN with HMASTKSTART = 0 and HMASKSTOP = 1560

VERTICAL TIMING GENERATION

The AD9937 provides a very flexible solution for generating vertical CCD timing, and can support multiple CCDs and different system architectures. The 4-phase vertical transfer clocks V1–V4 are used to shift each line of pixels into the horizontal output register of the CCD. The AD9937 allows these outputs to be individually programmed into different pulse patterns. Vertical sequence control registers then organize the individual vertical pulses into the desired CCD vertical timing arrangement.

The AD9937 can preprogram three unique sets of vertical transfer pulses known as VTP0, VTP1, and VTP2. Each VTP set consists of the four vertical clocks (V1A/B, V2, V3A/B, and V4), as shown in Figure 32. Once preprogrammed, any one of the three unique VTP sets can then be selected to be output in any one of the five CCD regions by using the VTPPATSELx (x = 0, 1, 2, 3, 4) registers. The VTP_Reg(1–9) registers listed in Table II are used for generating the VTP pulse sets.

Figure 32 shows an example of programming one VTPx (x = 0, 1, 2) pulse set. Once a VTP pulse set has been configured, multiple repetitions of this set can be repeated to create an entire VTP sequence. This is accomplished by using the VTPREPn (n = 0, 1, 2, 3, 4) registers where n represents the five CCD regions. An example of repeating a VTP set is shown in Figure 33.

CCD REGIONS

Up to five unique CCD regions can be preprogrammed using the sequence change position registers as described in Table XVII. The SCPx (x = 0, 1, 2, 3, 4) registers determine when the settings in Mode_Reg(15–19) are active. For example, the SCP1 register activates the registers at Mode_Reg(16) for CCD region 1. Note that SCP0 is not programmable. The SCP0 position always starts at Line 0, as shown in Figure 31.

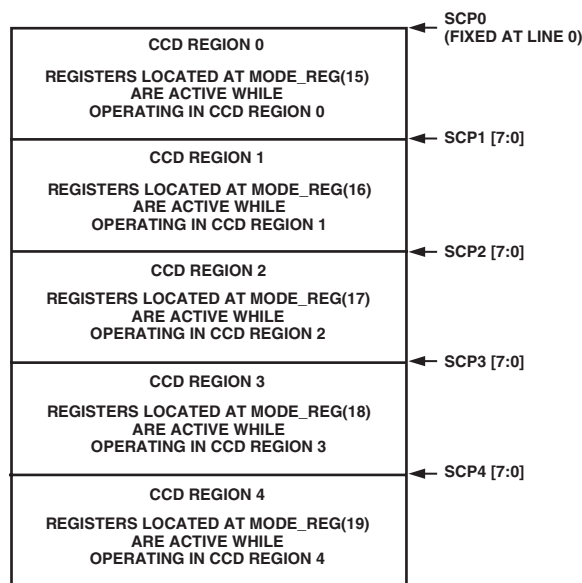
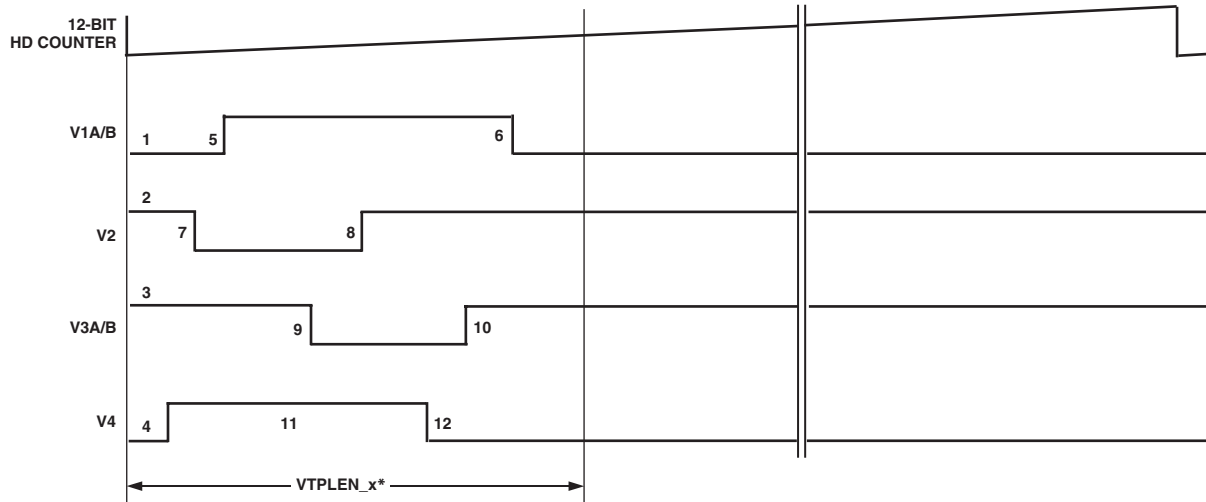

Figure 31. Sequence Change Positions

Table XVII. Sequence Change Positions Registers

Register Name*	Length (Bits)	Register Type	Range	Description
SCP1	8	Mode_Reg(14)	0–255 Line Positions	Sequence Change Position 1
SCP2	8	Mode_Reg(14)	0–255 Line Positions	Sequence Change Position 2
SCP3	8	Mode_Reg(14)	0–255 Line Positions	Sequence Change Position 3
SCP4	8	Mode_Reg(14)	0–255 Line Positions	Sequence Change Position 4

*There is no SCP0 register. The SCP0 position is always fixed at Line 0.



PROGRAMMING NOTES
 *(x = 0, 1, 2) THE x REPRESENTS THE THREE SEPARATE REGISTERS FOR VTP0, VTP1, AND VTP2 SETS. THIS ALSO APPLIES TO THE x USED IN THE PROGRAMMABLE CLOCK POSITIONS BELOW.

PROGRAMMABLE CLOCK POSITIONS

- | | |
|--|---|
| 1. V1POL_x (PROGRAMMABLE AT VTP_REG(x)) | 7. V2TOG1_x (PROGRAMMABLE AT VTP_REG(x)) |
| 2. V2POL_x (PROGRAMMABLE AT VTP_REG(x)) | 8. V2TOG2_x (PROGRAMMABLE AT VTP_REG(x)) |
| 3. V3POL_x (PROGRAMMABLE AT VTP_REG(x)) | 9. V3TOG1_x (PROGRAMMABLE AT VTP_REG(x)) |
| 4. V4POL_x (PROGRAMMABLE AT VTP_REG(x)) | 10. V3TOG2_x (PROGRAMMABLE AT VTP_REG(x)) |
| 5. V1TOG1_x (PROGRAMMABLE AT VTP_REG(x)) | 11. V4TOG1_x (PROGRAMMABLE AT VTP_REG(x)) |
| 6. V1TOG2_x (PROGRAMMABLE AT VTP_REG(x)) | 12. V4TOG2_x (PROGRAMMABLE AT VTP_REG(x)) |

Figure 32. Example of Programming One VTP Pulse

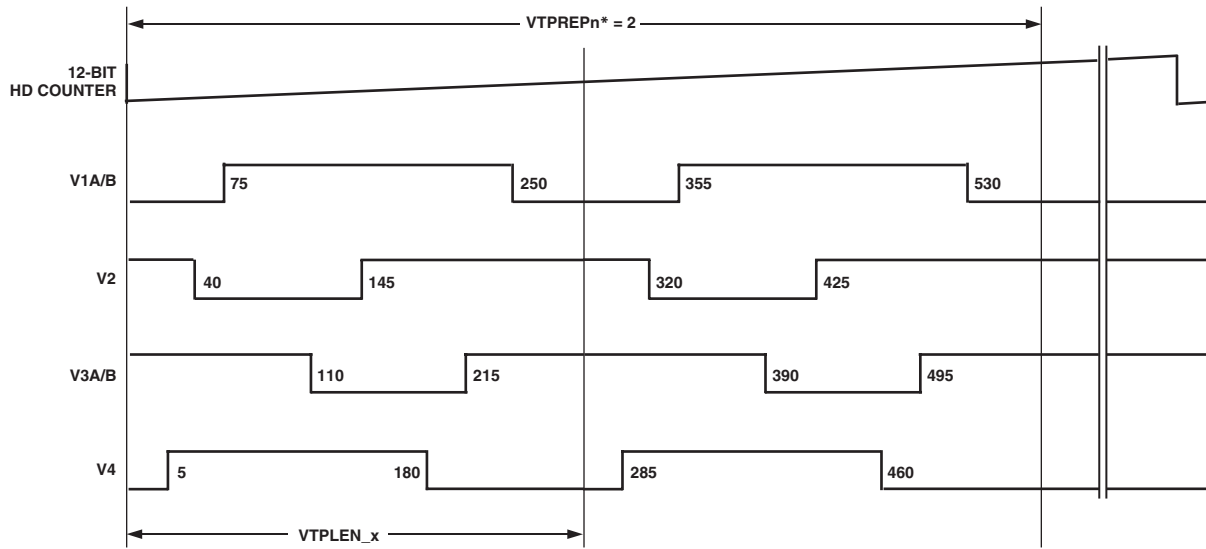

*(n = 0, 1, 2, 3, 4) n REPRESENTS THE NUMBER OF PROGRAMMABLE CCD REGIONS. THE NUMBER OF REPETITIONS IN EACH CCD REGION CAN BE INDEPENDENTLY SET USING THE VTPREP REGISTER FOR THAT REGION.

Figure 33. Example of Creating a Sequence of VTP Pulses by Using the VTPREP Register

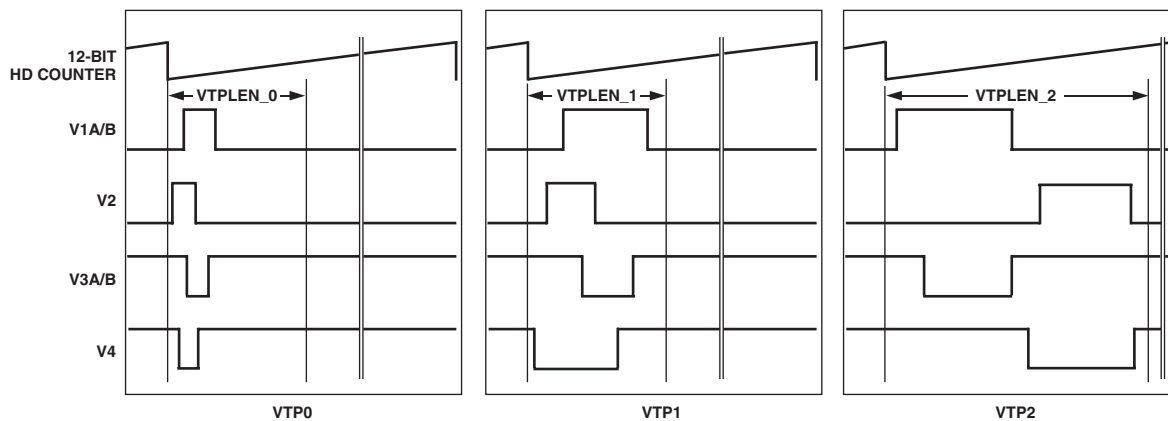

Figure 34. Example of Three Preprogrammed VTP Pulses

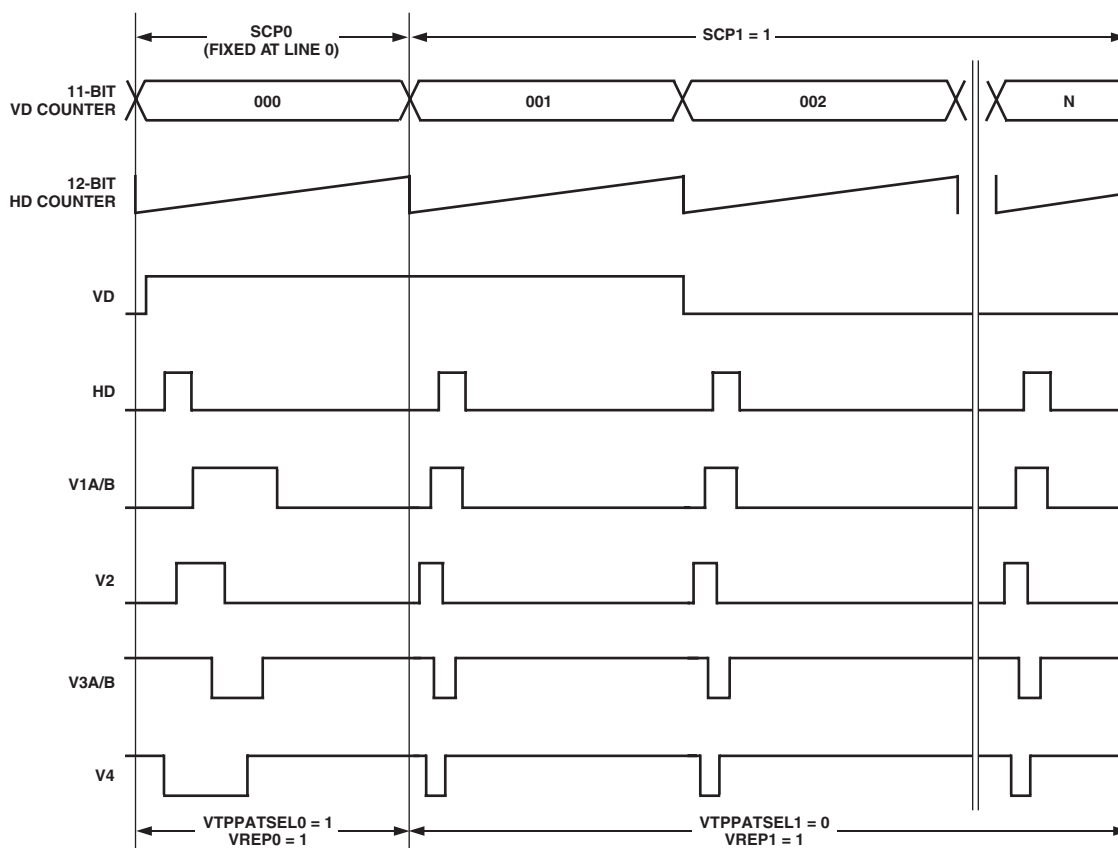

Figure 35. Example of Applying VTP Pulse Sequences to CCD Regions

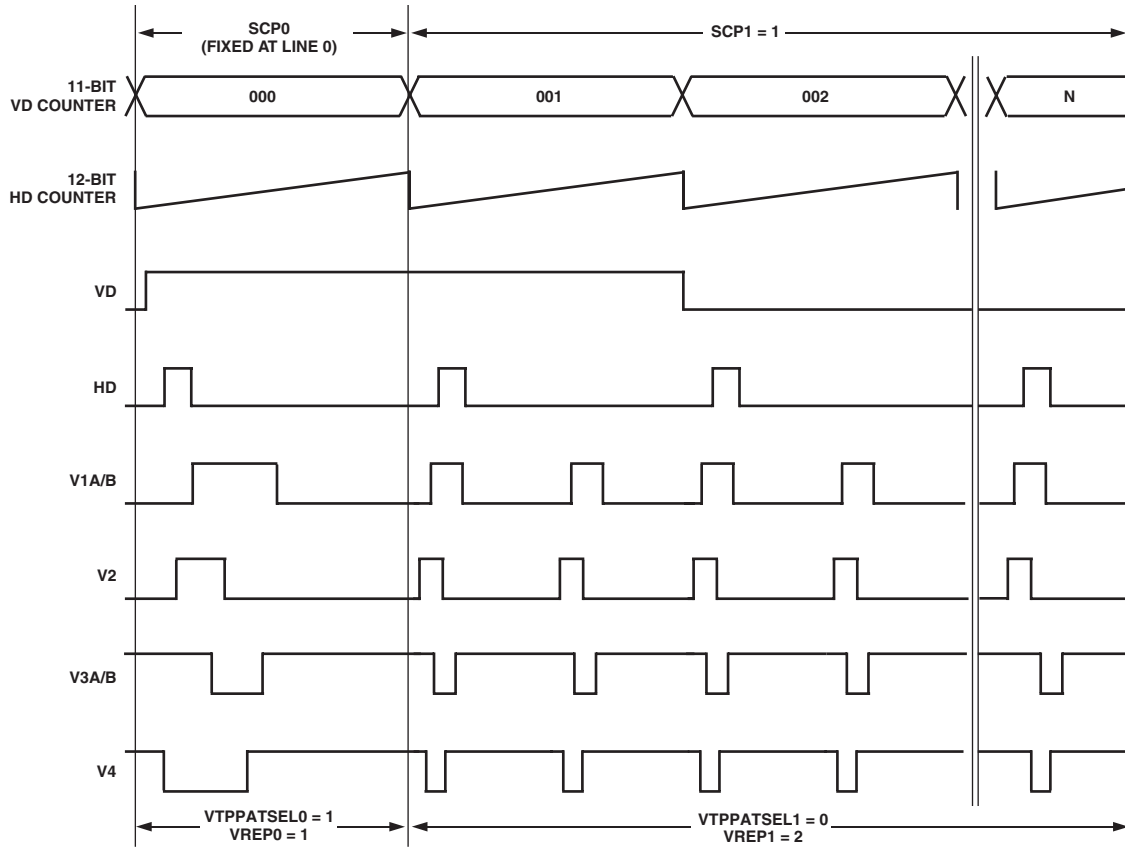

Figure 36. Example of VTP Pulse Sequence with VREP = 2 in CCD Region 1

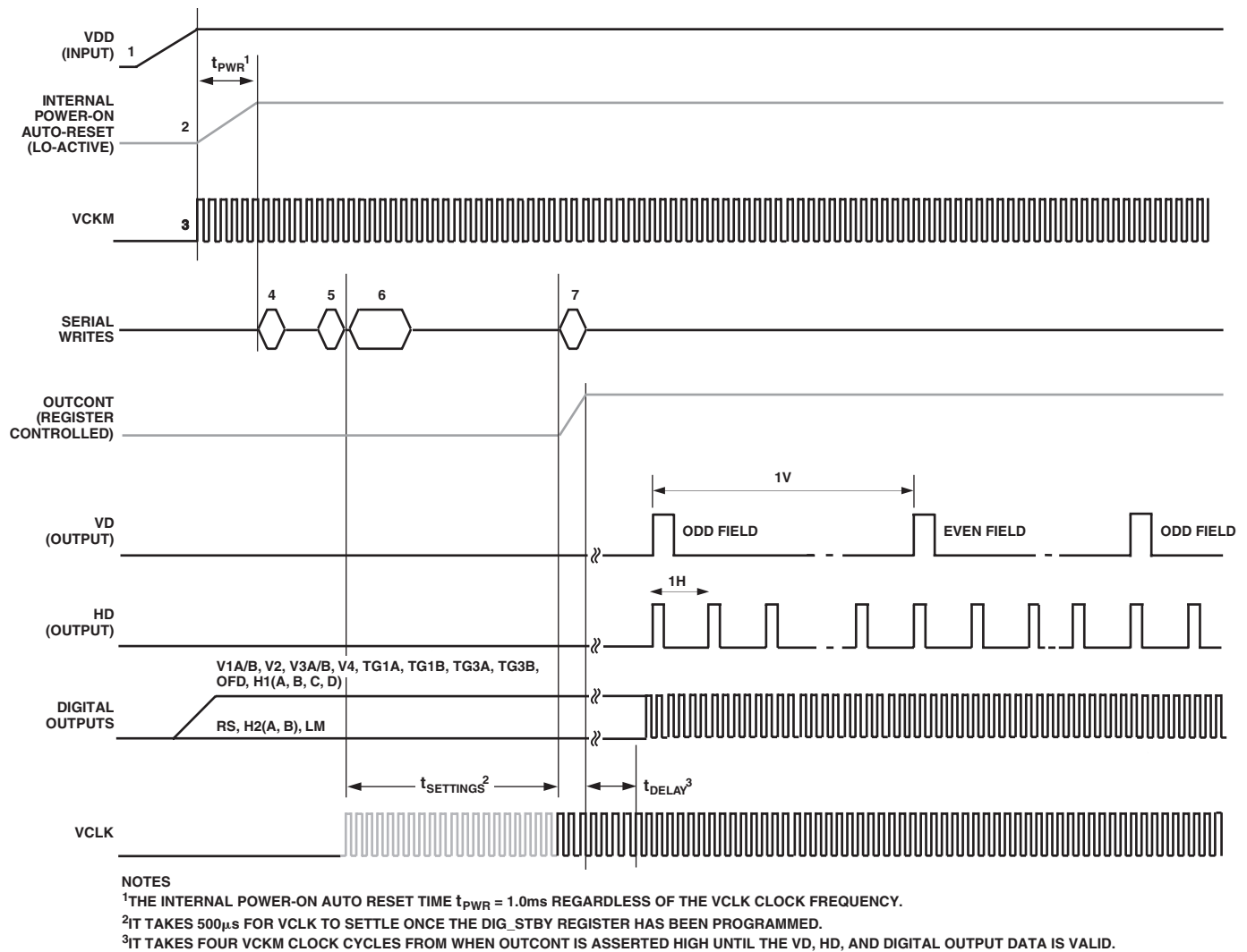

Figure 37. Recommended Power-Up Sequence

POWER-UP FOR MASTER MODE

When the AD9937 is powered up, the following sequence is recommended. (Refer to Figure 37 for each step.)

1. Turn on power supplies for AD9937.
2. The internal power-on auto-reset circuit will deassert 1.0 ms after VDD settles. (All internal registers are reset to the default values.)
3. The VCKM clock can be applied as soon as VDD settles.
4. Reset the internal AD9937 registers: write a 0x000000 to the SW_RESET register (addr 0x00). This will set all internal register values to their default values. (This step is optional because the internal power-on reset circuit is applied at power-up.)
5. Write a 1 to the DIG_STBY and AFE_STBY registers (addr 0x02). This will put the digital and analog circuits into the normal operating mode.
6. Program all control, system, and mode registers.
7. Write a 1 to the OUTCONT_REG (addr 0x01). This will put the digital outputs into the normal operating mode. The internal OUTCONT will be asserted high on the rising edge of the 32nd SCK clock when writing to the OUTCONT_REG.

**Table XVIII. Start-Up Polarities
(While OUTCONT = LO)**

Output	OUTCONT = LO
V1A/B	HI
V2	HI
V3A/B	HI
V4	HI
TG1A	HI
TG1B	HI
TG3A	HI
TG3B	HI
OFD	HI
H1(A-D)	HI
H2(A, B)	LO
LM	LO
RS	LO

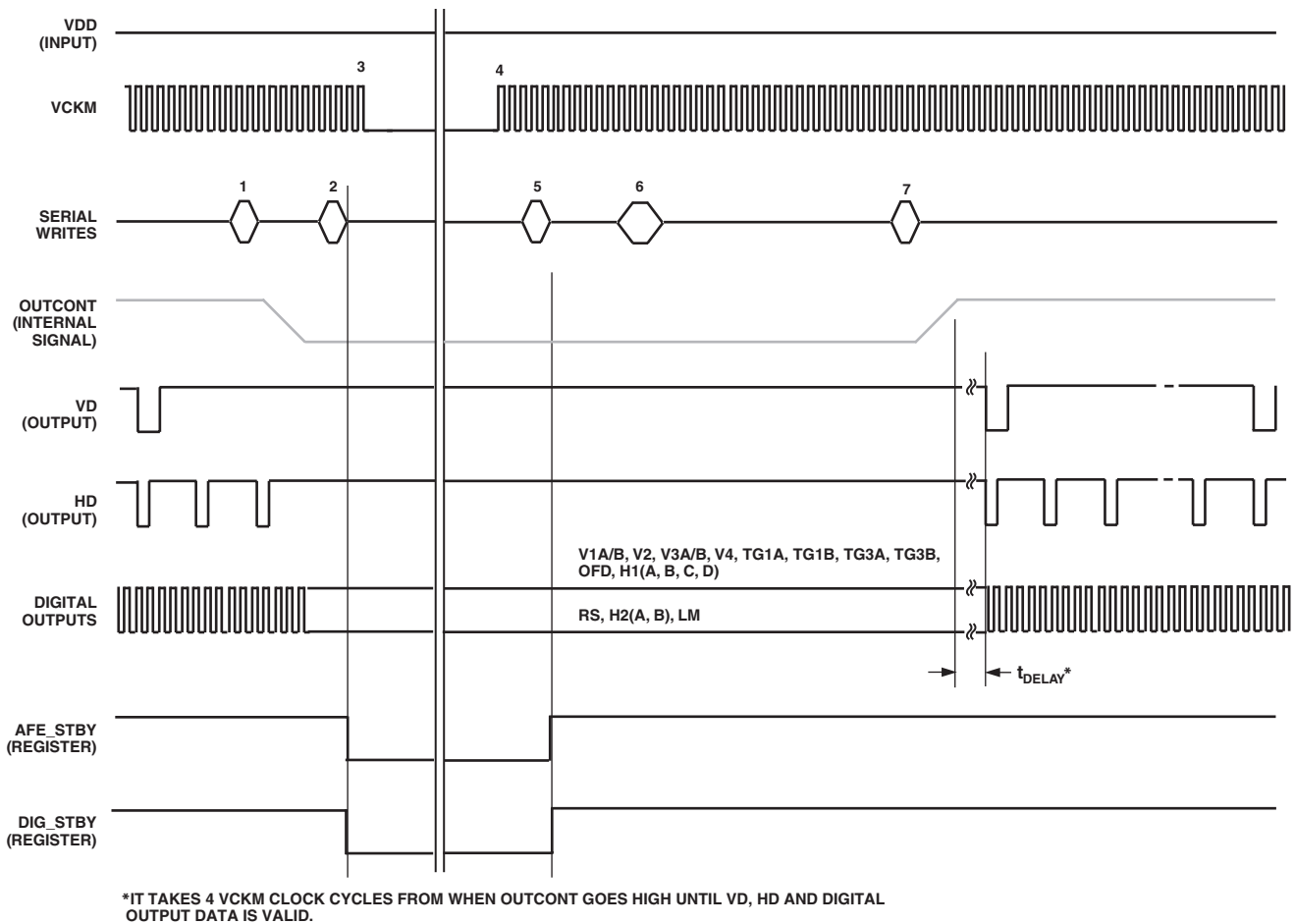

Figure 38. Recommended Standby Sequence

STANDBY SEQUENCE

The following sequence is recommended when the AD9937 is put into standby operation. (Refer to Figure 38 for each step.)

1. Write a 0 to the OUTCONT_REG register (addr 0x01).
2. Write a 0 to the DIG_STBY and AFE_STBY registers (addr 0x02). This will put the digital and analog circuits into the standby operating mode.
3. Stop VCKM clock. (This is optional.)
4. Apply VCKM when ready to come out of standby operation.
5. Write a 1 to the DIG_STBY and AFE_STBY registers (addr 0x02). This will put the digital and analog circuits into the normal operating mode.
6. Program any necessary control, system, or mode registers.
7. Write a 1 to the OUTCONT_REG register (addr 0x01) to begin operation.

POWER-DOWN SEQUENCE

The following sequence is recommended when AD9937 is being powered down. (Refer to Figure 39 for each step.)

1. Write a 0 to the OUTCONT_REG register (addr 0x01).

2. Write a 0 to the DIG_STBY and AFE_STBY registers (addr 0x02). This will put the digital and analog circuits into the standby operating mode.
3. Stop VCKM clock.
4. Turn off power supplies to AD9937.

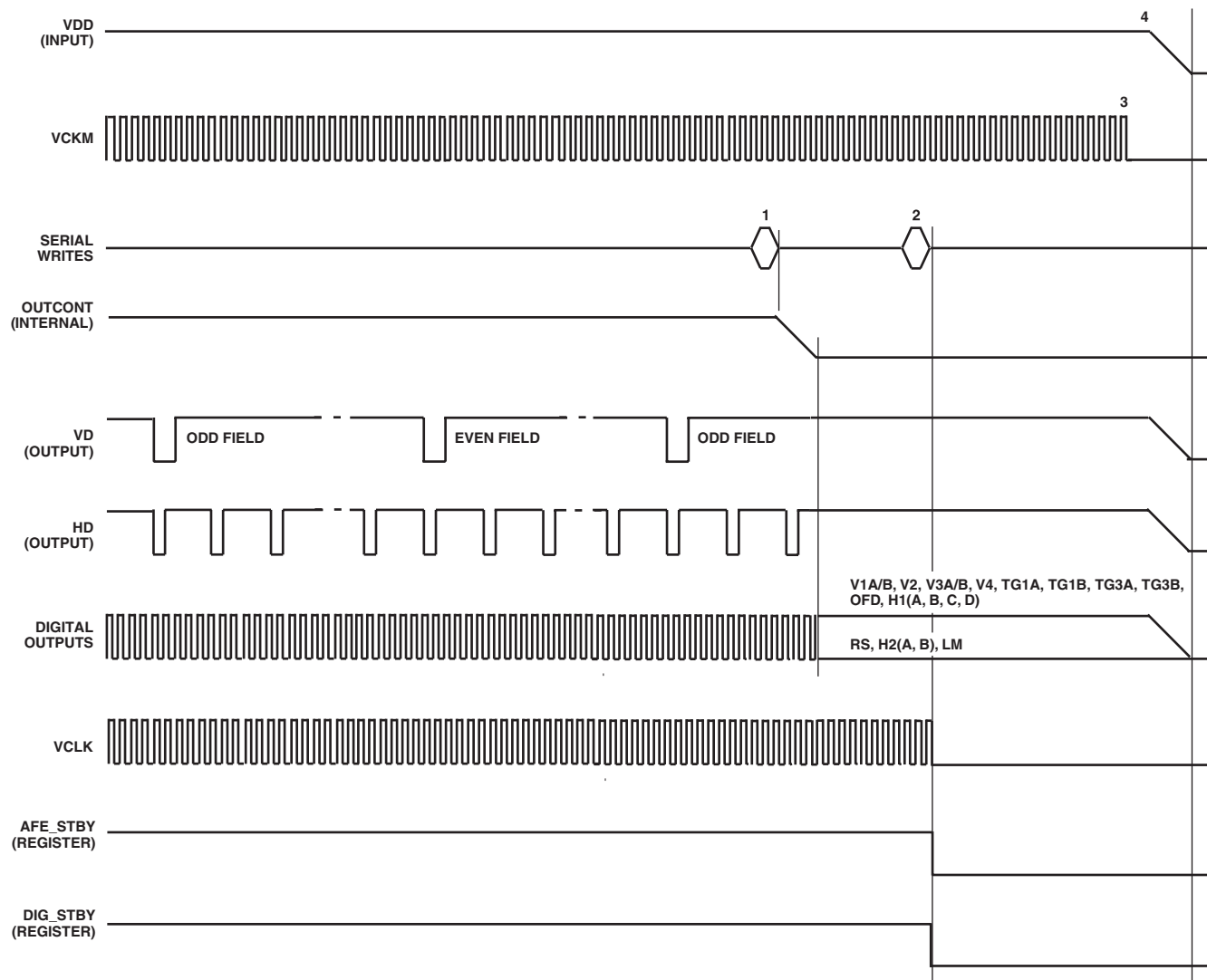

Figure 39. Recommended Power-Down Sequence

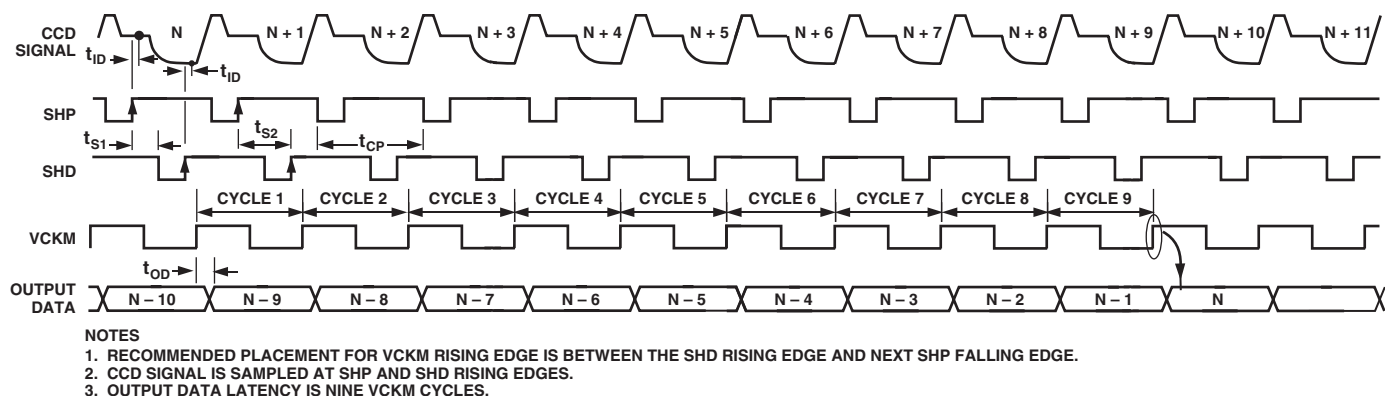

Figure 40. Pipeline Latency

AD9937

CIRCUIT LAYOUT INFORMATION

The AD9937 typical circuit connection is shown in Figure 41. The PCB layout is critical in achieving good image quality from the AD9937 product. All of the supply pins, particularly the AVDD, DVDD, TCVDD, RSVDD, HVDD1, and HVDD2 supplies, must be decoupled to ground with good quality high frequency chip capacitors. The decoupling capacitors should be located as close as possible to the supply pins, and should have a very low impedance path to a continuous ground plane. There should also be a 4.7 μF or larger value bypass capacitor for each main supply although this is not necessary for each individual pin.

In most applications, it is easier and recommended to share the same supply for AVDD, DVDD, TCVDD, RSVDD, HVDD1, and HVDD2, which may be done as long as the individual supply pins are separately bypassed at each supply pin. A separate 3 V supply should be used for DRVDD with this supply pin decoupled to the same ground plane as the rest of the chip. A separate ground for DRVSS is not recommended.

The analog bypass pins (REFB, REFT) should also be carefully decoupled to ground as close as possible to their respective pins. The analog input (CCDIN) capacitor should also be located close to the pin.

The H1(A–D), H2(A, B), and RS printed circuit board traces should be designed to have low inductance to avoid excessive distortion of the signals. Heavier traces are recommended, because of the large transient current demand on H1(A–D) and H2(A, B) by the CCD. If possible, physically locate the AD9937 closer to the CCD to reduce the inductance on these lines. As always, the routing path should be as direct as possible from the AD9937 to the CCD. Careful trace impedance considerations must also be made with applications using a flex printed circuit (FPC) connecting the CCD to the AD9937. FPC trace impedances can be controlled by applying a solid uniform ground plane under the H1(A–D), H2(A, B), and RS traces. This helps minimize the amount of overshoot and ringing on these signals at the CCD inputs.

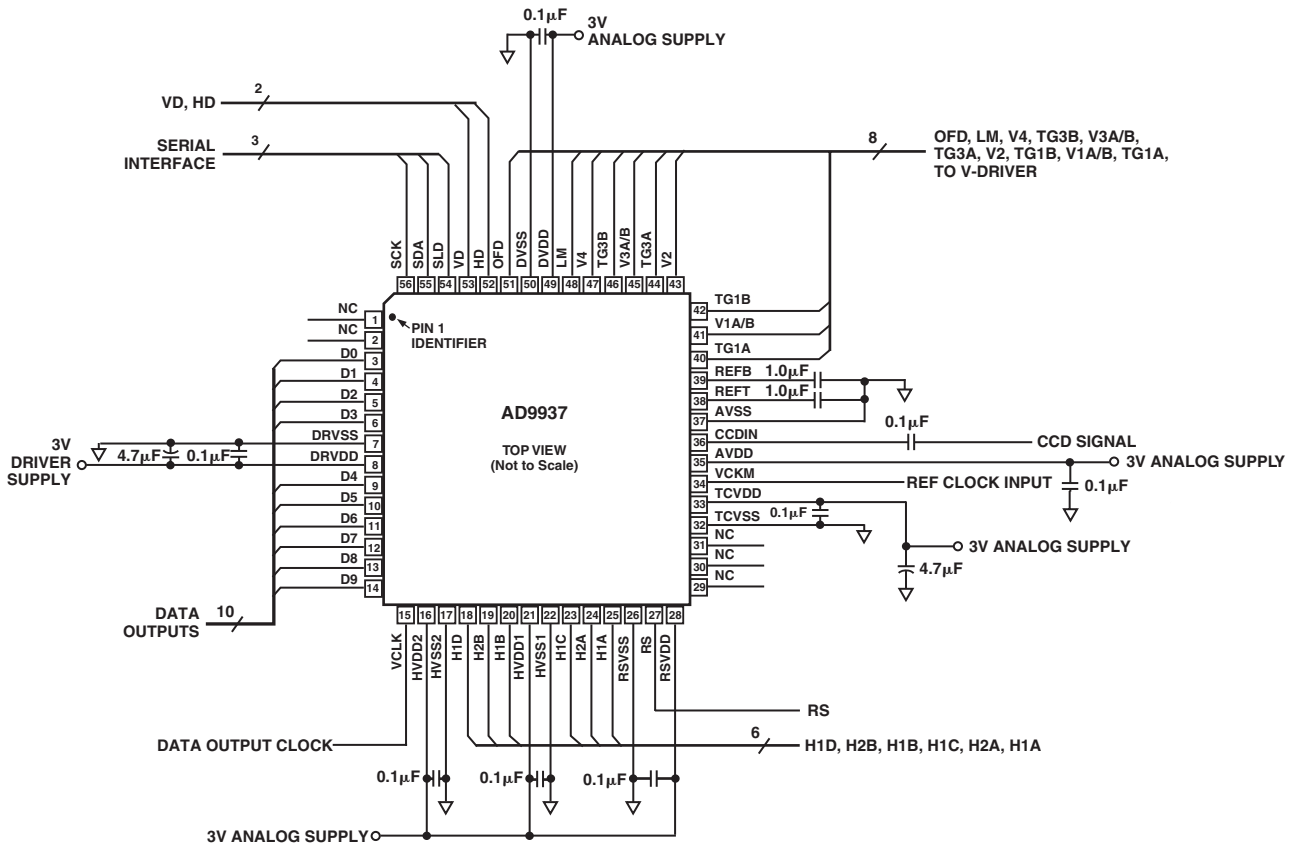

Figure 41. Typical Circuit Configuration

Figures 42 and 43 show the recommended AD9937 supply grouping. Figure 42 shows how the supplies should be tied together when there are only two available supply sources, whereas Figure 43 shows how the supplies can be tied together when there are three

available supply sources. In either case, all grounds should be tied together as shown.

Also as shown in Figures 42 and 43 is that the AD9937 DRVDD supply can be shared with the system ASIC/DSP.

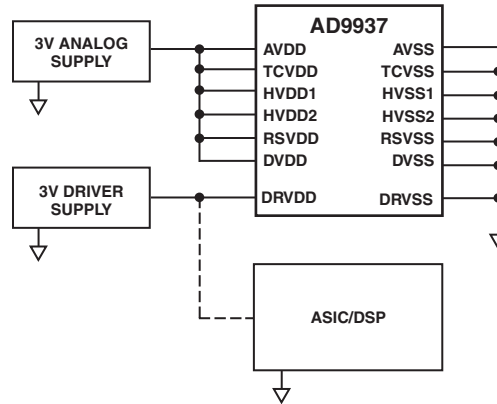

Figure 42. Recommended Supply Grouping with Two Available Supply Sources

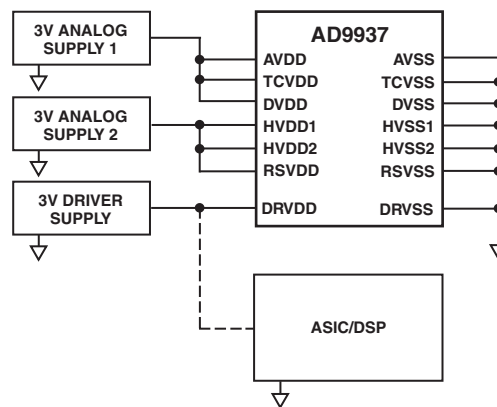

Figure 43. Recommended Supply Grouping with Three Available Supply Sources

Looking for pricing, stock, or lifecycle information?

Click below to explore more details on WIN SOURCE:

 [View AD9937BCPZ-24 on WIN SOURCE](#)

 [Analog Devices Inc. Information](#)

Optimize Your Supply Chain with WIN SOURCE Solutions

-  Global Sourcing Solution
-  Obsolete Management
-  Cost Control Management
-  Shortage Management
-  Alternative Solution
-  Excess Inventory Management