



**THE DATASHEET OF  
AD9920ABBCZ**





### FEATURES

- Integrated 19-channel V-driver
- 1.8 V AFETG core
- 24 programmable vertical clock signals
- Correlated double sampler (CDS) with -3 dB, 0 dB, +3 dB, and +6 dB gain
- 12-bit, 40.5 MHz analog-to-digital converter (ADC)
- Black level clamp with variable level control
- Complete on-chip timing generator
- Precision Timing core with ~400 ps resolution
- On-chip 3 V horizontal and RG drivers
- General-purpose outputs (GPOs) for shutter and system support
- On-chip sync generator with external sync input
- On-chip 1.8 V low dropout (LDO) regulator
- 105-ball, 8 mm x 8 mm CSP\_BGA package

### APPLICATIONS

Digital still cameras

### GENERAL DESCRIPTION

The AD9920A is a highly integrated charge-coupled device (CCD) signal processor for digital still camera applications. It includes a complete analog front end (AFE) with analog-to-digital conversion, combined with a full-function programmable timing generator and 19-channel vertical driver (V-driver). The timing generator is capable of supporting up to 24 vertical clock signals to control advanced CCDs. The on-chip V-driver supports up to 19 channels for use with six-field CCDs. A Precision Timing® core allows adjustment of high speed clocks with approximately 400 ps resolution at 40.5 MHz operation. The AD9920A also contains six GPOs that can be used for shutter and system functions.

The analog front end includes black level clamping, variable gain CDS, and a 12-bit ADC. The timing generator provides all the necessary CCD clocks: RG, H-clocks, V-clocks, sensor gate pulses, substrate clock, and substrate bias control.

The AD9920A is specified over an operating temperature range of -25°C to +85°C.

### FUNCTIONAL BLOCK DIAGRAM

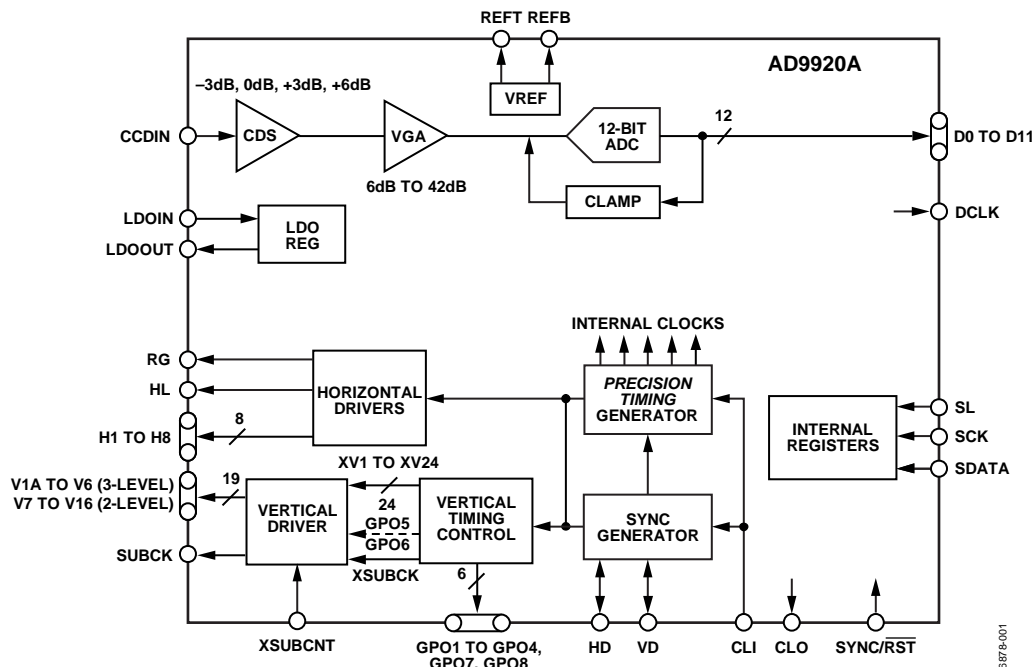

Figure 1.

### Rev. B

Information furnished by Analog Devices is believed to be accurate and reliable. However, no responsibility is assumed by Analog Devices for its use, nor for any infringements of patents or other rights of third parties that may result from its use. Specifications subject to change without notice. No license is granted by implication or otherwise under any patent or patent rights of Analog Devices. Trademarks and registered trademarks are the property of their respective owners.

## TABLE OF CONTENTS

Features .....	1	V-Driver Slew Rate Control.....	60
Applications.....	1	Shutter Timing Control.....	60
General Description.....	1	Substrate Clock Operation (SUBCK) .....	60
Functional Block Diagram .....	1	Field Counters.....	63
Revision History .....	3	General-Purpose Outputs (GPOs) .....	64
Specifications.....	4	GP Lookup Table (LUT).....	68
Digital Specifications .....	5	Complete Exposure/Readout Operation Using Primary Counter and GPO Signals.....	69
Analog Specifications.....	5	SG Control Using GPO .....	71
Timing Specifications .....	7	Manual Shutter Operation Using Enhanced SYNC Modes..	73
Vertical Driver Specifications .....	8	Analog Front End Description and Operation .....	77
Absolute Maximum Ratings.....	10	Applications Information .....	79
Thermal Resistance .....	10	Power-Up Sequence for Master Mode.....	79
ESD Caution.....	10	Power-Up Sequence for Slave Mode.....	81
Pin Configuration and Function Descriptions.....	11	Power-Down Sequence for Master and Slave Modes.....	83
Typical Performance Characteristics .....	14	Additional Restrictions in Slave Mode.....	84
Equivalent Circuits .....	15	Vertical Toggle Position Placement Near Counter Reset.....	85
Terminology .....	16	Standby Mode Operation .....	86
Theory of Operation .....	17	CLI Frequency Change.....	86
H-Counter Behavior in Slave Mode.....	17	Circuit Layout Information.....	88
High Speed <i>Precision Timing Core</i> .....	18	Typical 3 V System .....	88
Digital Data Outputs.....	22	External Crystal Application .....	88
Horizontal Clamping and Blanking.....	23	Circuit Configurations .....	89
Horizontal Timing Sequence Example.....	30	Serial Interface .....	93
Vertical Timing Generation .....	32	Serial Interface Timing.....	93
Vertical Sequences (VSEQ).....	34	Layout of Internal Registers.....	94
Vertical Timing Example.....	51	Updating New Register Values .....	95
Internal Vertical Driver Connections (18-Channel Mode)..	53	Complete Register Listing .....	96
Internal Vertical Driver Connections (19-Channel Mode)..	54	Outline Dimensions .....	112
Output Polarity of Vertical Transfer Clocks and Substrate Clock .....	55	Ordering Guide .....	112

**REVISION HISTORY****6/10—Rev. A to Rev. B**

Changes to Figure 1.....	1	Changes to Figure 96 .....	75
Changes to Figure 9, Figure 10, Figure 12, and Figure 13 .....	15	Changes to Figure 100 .....	77
Moved Terminology Section.....	16	Changes to Figure 102 .....	80
Changes to Figure 15 .....	17	Changes to Power-Up Sequence for Slave Mode Section .....	81
Moved Generating HBLK Line Alternation Section .....	24	Changes to Figure 103 .....	82
Moved Figure 32.....	25	Changes to Power-Down Sequence for Master and Slave Modes Section.....	83
Moved Figure 33.....	27	Added Table 48; Renumbered Tables Sequentially.....	86
Changes to Vertical Sequences (VSEQ) Section .....	34	Changes to Figure 108 .....	88
Changes to Special Vertical Sequence Alternation (SVSA) Mode Section .....	38	Changes to Figure 109 .....	89
Added Table 18; Renumbered Tables Sequentially .....	44	Changes to Figure 110 .....	90
Deleted Figure 77; Renumbered Figures Sequentially .....	61	Changes to Figure 111 .....	91
Changes to SUBCK Low Speed Operation Section and Table 43 .....	61	Changes to Figure 112 .....	92
Changes to Figure 81 .....	62	Changes to Layout of Internal Registers Section and Figure 115 .....	94
Changes to Table 45 .....	64	Changes to Table 53 .....	97
Changes to Scheduled Toggles Section and Figure 85 .....	66	Changes to Table 57 .....	99
Changes to Figure 86, ShotTimer Sequences Section, and Figure 87 .....	67	Changes to Table 59 .....	101
Changes to Complete Exposure/Readout Operation Using Primary Counter and GPO Signals Section .....	69	Changes to Table 61 .....	105
Changes to Triggered Control of GPO5 Section.....	71	Changes to Table 63 .....	108
		Updated Outline Dimensions.....	112

**6/09—Revision A: Initial Version**

# AD9920A

## SPECIFICATIONS

Table 1.

Parameter	Test Conditions/Comments	Min	Typ	Max	Unit
TEMPERATURE RANGE					
Operating		-25		+85	°C
Storage		-65		+150	°C
POWER SUPPLY VOLTAGE INPUTS					
AVDD	AFE analog supply	1.6	1.8	2.0	V
TCVDD	Timing core supply	1.6	1.8	2.0	V
CLIVDD	CLI input supply	1.6	3.0	3.6	V
RGVDD	RG, HL driver supply	2.1	3.0	3.6	V
HVDD1 and HVDD2	H1 to H8 driver supplies	2.1	3.0	3.6	V
DVDD	Digital logic supply	1.6	1.8	2.0	V
DRVDD	Parallel data output driver supply	1.6	3.0	3.6	V
IOVDD	Digital I/O supply	1.6	3.0	3.6	V
V-DRIVER POWER SUPPLY VOLTAGES					
VDVDD	V-driver/logic supply	1.6	3.0	3.6	V
VH1, VH2	V-driver high supply	11.0	15.0	16.5	V
VL1, VL2	V-driver low supply	-8.5	-7.5	-5.5	V
VM1, VM2	V-driver midsupply	-1.5	0.0	+1.5	V
VLL	SUBCK low supply	-11.0	-7.5	-5.5	V
VH1, VH2 to VL1, VL2, VLL				23.5	V
VMM <sup>1</sup>	SUBCK midsupply	VLL	0.0	VDVDD	V
LDO <sup>2</sup>					
LDOIN	LDO supply input	2.5	3.0	3.6	V
Output Voltage		1.8	1.9	2.05	V
Output Current		60	100		mA
POWER SUPPLY CURRENTS—40.5 MHz OPERATION					
AVDD	1.8 V		27		mA
TCVDD	1.8 V		5		mA
CLIVDD	3 V		1.5		mA
RGVDD	3.3 V, 20 pF RG load, 20 pF HL load		10		mA
HVDD1 and HVDD2 <sup>3</sup>	3.3 V, 480 pF total load on H1 to H8		59		mA
DVDD	1.8 V		9.5		mA
DRVDD	3 V, 10 pF load on each data output pin (D0 to D11)		6		mA
IOVDD	3 V, depends on load and output frequency of digital I/O		2		mA
POWER SUPPLY CURRENTS—STANDBY MODE OPERATION					
Standby1 Mode			20		mA
Standby2 Mode			5		mA
Standby3 Mode			1.5		mA
MAXIMUM CLOCK RATE (CLI)		40.5		MHz	
MINIMUM CLOCK RATE (CLI)		10		MHz	

<sup>1</sup> VMM must be greater than VLL and less than VDVDD.

<sup>2</sup> LDO should be used only for the AD9920A 1.8 V supplies, not for external circuitry.

<sup>3</sup> The total power dissipated by the HVDD (or RGVDD) can be approximated using the following equation:

$$\text{Total HVDD Power} = (C_L \times \text{HVDD} \times \text{Pixel Frequency}) \times \text{HVDD}$$

**DIGITAL SPECIFICATIONS**

IOVDD = 1.6 V to 3.6 V, RGVDD = HVDD1 and HVDD2 = 2.7 V to 3.6 V,  $C_L = 20$  pF,  $T_{MIN}$  to  $T_{MAX}$ , unless otherwise noted.

**Table 2.**

Parameter	Symbol	Test Conditions/Comments	Min	Typ	Max	Unit
LOGIC INPUTS (IOVDD)						
High Level Input Voltage	$V_{IH}$		$V_{DD} - 0.6$			V
Low Level Input Voltage	$V_{IL}$				0.6	V
High Level Input Current	$I_{IH}$			10		$\mu$ A
Low Level Input Current	$I_{IL}$			10		$\mu$ A
Input Capacitance	$C_{IN}$			10		pF
LOGIC OUTPUTS (IOVDD, DRVDD)						
High Level Output Voltage	$V_{OH}$	$I_{OH} = 2$ mA	$V_{DD} - 0.5$			V
Low Level Output Voltage	$V_{OL}$	$I_{OL} = 2$ mA			0.5	V
RG and H-DRIVER OUTPUTS (HVDD1, HVDD2, and RGVDD)						
High Level Output Voltage	$V_{OH}$	Maximum current	$V_{DD} - 0.5$			V
Low Level Output Voltage	$V_{OL}$	Maximum current			0.5	V
Maximum H1 to H8 Output Current		Programmable	30			mA
Maximum HL and RG Output Current		Programmable	17			mA
Maximum Load Capacitance		Each output	60			pF
CLI INPUT						
High Level Input Voltage	$V_{IHCLI}$	With CLO oscillator disabled	$CLIVDD/2 + 0.5$			V
Low Level Input Voltage	$V_{ILCLI}$				$CLIVDD/2 - 0.5$	V

**ANALOG SPECIFICATIONS**

AVDD = 1.8 V,  $f_{CLI} = 40.5$  MHz, typical timing specifications,  $T_{MIN}$  to  $T_{MAX}$ , unless otherwise noted.

**Table 3.**

Parameter	Test Conditions/Comments	Min	Typ	Max	Unit
CDS <sup>1</sup>					
DC Restore	AVDD – 0.5 V	1.21	1.3	1.44	V
Allowable CCD Reset Transient	Limit is the lower of AVDD + 0.3 V or 2.2 V		0.5	0.8	V
CDS Gain Accuracy	VGA gain = 6.3 dB (Code 15, default value)				
–3 dB CDS Gain		–3.1	–2.6	–2.1	dB
0 dB CDS Gain		–0.6	–0.1	+0.4	dB
+3 dB CDS Gain		2.7	3.2	3.7	dB
+6 dB CDS Gain		5.2	5.7	6.2	dB
Maximum Input Range Before Saturation					
–3 dB CDS Gain			1.4		V p-p
0 dB CDS Gain			1.0		V p-p
+3 dB CDS Gain			0.7		V p-p
+6 dB CDS Gain			0.5		V p-p
Allowable OB Pixel Amplitude <sup>1</sup>					
0 dB CDS Gain (Default)		–100		+200	mV
+6 dB CDS Gain		–50		+100	mV
VARIABLE GAIN AMPLIFIER (VGA)					
Gain Control Resolution			1024		Steps
Gain Monotonicity			Guaranteed		
Gain Range					
Low Gain	VGA Code 15, default		6.3		dB
Maximum Gain	VGA Code 1023		42.4		dB

# AD9920A

Parameter	Test Conditions/Comments	Min	Typ	Max	Unit
BLACK LEVEL CLAMP					
Clamp Level Resolution			1024		Steps
Clamp Level	Measured at ADC output				
Minimum Clamp Level	Code 0		0		LSB
Maximum Clamp Level	Code 1023		255		LSB
ADC					
Resolution		12			Bits
Differential Nonlinearity (DNL) <sup>2</sup>			±0.5		LSB
No Missing Codes			Guaranteed		
Integral Nonlinearity (INL) <sup>2</sup>			±3.0		LSB
Full-Scale Input Voltage			2.0		V
VOLTAGE REFERENCE					
Reference Top Voltage (REFT)			1.4		V
Reference Bottom Voltage (REFB)			0.4		V
SYSTEM PERFORMANCE	Includes entire signal chain				
Gain Accuracy	0 dB CDS gain				
Low Gain	VGA Code 15 Gain = (0.0358 × code) + 5.76 dB	5.7	6.2	6.7	dB
Maximum Gain	VGA Code 1023	41.8	42.3	42.8	dB
Peak Nonlinearity, 1 V Input Signal <sup>2</sup>	6 dB VGA gain, 0 dB CDS gain applied		0.1	0.3	%
Total Output Noise <sup>2</sup>	AC-grounded input, 6 dB VGA gain applied		0.6		LSB rms
Power Supply Rejection (PSR) <sup>2</sup>	Measured with step change on supply		40		dB

<sup>1</sup> Input signal characteristics are defined as shown in Figure 2.

<sup>2</sup> See the Terminology section.

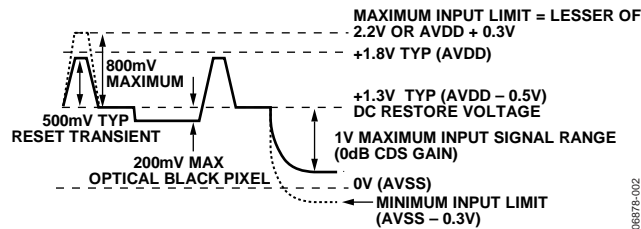

Figure 2. Input Signal Characteristics

06878-002

## TIMING SPECIFICATIONS

$C_L = 20$  pF,  $AVDD = DVDD = TCVDD = 1.8$  V,  $f_{CLI} = 40.5$  MHz, unless otherwise noted.

Table 4.

Parameter	Test Conditions/ Comments	Symbol	Min	Typ	Max	Unit
MASTER CLOCK	See Figure 18					
CLI Clock Period		$t_{CONV}$	24.7			ns
CLI High/Low Pulse Width			$0.8 \times t_{CONV}/2$	$t_{CONV}/2$	$1.2 \times t_{CONV}/2$	ns
Delay from CLI Rising Edge to Internal Pixel Position 0		$t_{CLIDLy}$		6		ns
SLAVE MODE SPECIFICATIONS	See Figure 105					
VD Falling Edge to HD Falling Edge		$t_{VDHD}$	0		VD period – $t_{CONV}$	ns
HD Falling Edge to CLI Rising Edge	Only valid if $OSC\_RST = 0$	$t_{HDCLI}$	3		$t_{CONV} - 2$	ns
HD Falling Edge to CLO Rising Edge	Only valid if $OSC\_RST = 1$	$t_{HDCLo}$	3		$t_{CONV} - 2$	ns
CLI Rising Edge to SHPLOC	Internal sample edge	$t_{CLISHP}$	3		$t_{CONV} - 2$	ns
AFE						
SHPLOC Sample Edge to SHDLOC Sample Edge	See Figure 23	$t_{s1}$	$0.8 \times t_{CONV}/2$	$t_{CONV}/2$	$t_{CONV} - t_{s2}$	ns
SHDLOC Sample Edge to SHPLOC Sample Edge	See Figure 23	$t_{s2}$	$0.8 \times t_{CONV}/2$	$t_{CONV}/2$	$t_{CONV} - t_{s1}$	ns
AFE Pipeline Delay	See Figure 26			16		Cycles
AFE CLPOB Pulse Width			2	20		Pixels
DATA OUTPUTS						
Output Delay from DCLK Rising Edge	See Figure 25	$t_{OD}$		1		ns
Pipeline Delay from SHP/SHD Sampling to Data Output				16		Cycles
SERIAL INTERFACE						
Maximum SCK Frequency	Must not exceed CLI frequency	$f_{SCLK}$	40.5			MHz
SL to SCK Setup Time		$t_{LS}$	10			ns
SCK to SL Hold Time		$t_{LH}$	10			ns
SDATA Valid to SCK Rising Edge Setup		$t_{DS}$	10			ns
SCK Falling Edge to SDATA Valid Hold		$t_{DH}$	10			ns
TIMING CORE SETTING RESTRICTIONS						
Inhibited Region for SHP Edge Location <sup>1</sup>	See Figure 23	$t_{SHPINH}$	50		62	Edge location
Inhibited Region for SHP or SHD with Respect to H-Clocks <sup>2, 3, 4</sup>	See Figure 23 and Figure 24					
RETIME = 0, MASK = 0		$t_{SHDINH}$	HxNEGLOC – 14		HxNEGLOC – 2	Edge location
RETIME = 0, MASK = 1		$t_{SHDINH}$	HxPOSLOC – 14		HxPOSLOC – 2	Edge location
RETIME = 1, MASK = 0		$t_{SHPINH}$	HxNEGLOC – 14		HxNEGLOC – 2	Edge location
RETIME = 1, MASK = 1		$t_{SHPINH}$	HxPOSLOC – 14		HxPOSLOC – 2	Edge location
Inhibited Region for DOUTPHASE Edge Location	See Figure 23	$t_{DOUTINH}$	SHDLOC + 1		SHDLOC + 12	Edge location

<sup>1</sup> Applies only to slave mode operation. The inhibited area for SHP is needed to meet the timing requirement for  $t_{CLISHP}$  for proper H-counter reset operation.

<sup>2</sup> When the HBLKRETIME bits (Address 0x35, Bits[3:0]) are enabled, the inhibit region for the SHD location changes to the inhibit region for the SHP location.

<sup>3</sup> When the HBLK masking polarity registers (V-sequence Register 0x18[24:21]) are set to 0, the H-edge reference becomes HxNEGLOC.

<sup>4</sup> The H-clock signals that have SHP/SHD inhibit regions depend on the HCLK mode: Mode 1 = H1; Mode 2 = H1, H2; Mode 3 = H1, H3; and 3-Phase Mode = Phase 1, Phase 2, and Phase 3.

# AD9920A

## VERTICAL DRIVER SPECIFICATIONS

VH1, VH2 = 12 V; VM1, VM2, VMM = 0 V; VL1, VL2, VLL = -6 V;  $C_L$  shown in load model;  $T_A = 25^\circ\text{C}$ .

Table 5.

Parameter	Symbol	Test Conditions/Comments	Min	Typ	Max	Unit
V1A TO V13		Simplified load conditions, 3000 pF to ground + 30 $\Omega$ in series, SRSW = VSS				
Delay Time, VL to VM and VM to VH	$t_{PLM}, t_{PMH}$			40		ns
Delay Time, VM to VL and VH to VM	$t_{PML}, t_{PHM}$			40		ns
Rise Time, VL to VM	$t_{RLM}$			150		ns
Rise Time, VM to VH	$t_{RMH}$			315		ns
Fall Time, VM to VL	$t_{FML}$			250		ns
Fall Time, VH to VM	$t_{FHM}$			165		ns
Output Currents						
At -7.25 V				10		mA
At -0.25 V				-22		mA
At +0.25 V				22		mA
At +14.75 V				-10		mA
$R_{ON}$					35	$\Omega$
V14, V15, V16		Simplified load conditions, 3000 pF to ground + 30 $\Omega$ in series				
Delay Time, VL to VM	$t_{PLM}$			45		ns
Delay Time, VM to VL	$t_{PML}$			45		ns
Rise Time, VL to VM	$t_{RLM}$			345		ns
Fall Time, VM to VL	$t_{FML}$			280		ns
Output Currents						
At -7.25 V				10		mA
At -0.25 V				-7		mA
$R_{ON}$					55	$\Omega$
SUBCK OUTPUT		Simplified load conditions, 1000 pF to ground				
Delay Time, VLL to VH	$t_{PLH}$			50		ns
Delay Time, VH to VLL	$t_{PHL}$			50		ns
Delay Time, VLL to VMM	$t_{PLM}$			50		ns
Delay Time, VMM to VH	$t_{PMH}$			50		ns
Delay Time, VH to VMM	$t_{PHM}$			50		ns
Delay Time, VMM to VLL	$t_{PML}$			50		ns
Rise Time, VLL to VH	$t_{RLH}$			50		ns
Rise Time, VLL to VMM	$t_{RLM}$			55		ns
Rise Time, VMM to VH	$t_{RMH}$			50		ns
Fall Time, VH to VLL	$t_{FHL}$			55		ns
Fall Time, VH to VMM	$t_{FHM}$			100		ns
Fall Time, VMM to VLL	$t_{FML}$			40		ns
Output Currents						
At -7.25 V				20		mA
At -0.25 V				-12		mA
At +0.25 V				12		mA
At +14.75 V				-20		mA
$R_{ON}$					35	$\Omega$
SRCTL INPUT RANGE		Valid only when SRSW is high	0.8		VDVDD	V

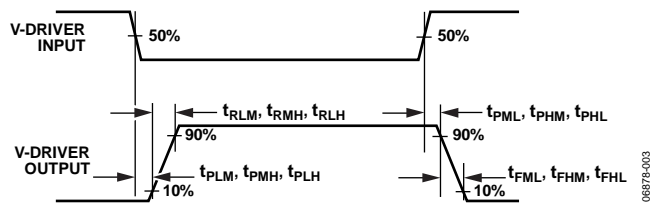

Figure 3. Definition of V-Driver Timing Specifications

## ABSOLUTE MAXIMUM RATINGS

Table 6.

Parameter	Rating
AVDD to AVSS	-0.3 V to +2.2 V
TCVDD to TCVSS	-0.3 V to +2.2 V
HVDD1, HVDD2 to HVSS1, HVSS2	-0.3 V to +3.9 V
RGVDD to RGVSS	-0.3 V to +3.9 V
DVDD to DVSS	-0.3 V to +2.2 V
DRVDD to DRVSS/LDOVSS	-0.3 V to +3.9 V
IOVDD to IOVSS	-0.3 V to +3.9 V
VDVDD to VDVSS	-0.3 V to +3.9 V
CLIVDD to TCVSS	-0.3 V to +3.9 V
VH1, VH2 to VL1, VL2, VLL	-0.3 V to +25.0 V
VH1, VH2 to VDVSS	-0.3 V to +17.0 V
VL1, VL2 to VDVSS	-17.0 V to +0.3 V
VM1, VM2 to VDVSS	-6.0 V to +3.0 V
VLL to VDVSS	-17.0 V to +0.3 V
VMM to VDVSS	VLL - 0.3 V to VDVDD + 0.3 V
V1A to V16 to VDVSS	VLx - 0.3 V to VHx + 0.3 V
RG and HL Outputs to RGVSS	-0.3 V to RGVDD + 0.3 V
H1 to H8 Outputs to HVSSx	-0.3 V to HVDDx + 0.3 V
VDR_EN, XSUBCNT, SRCTL, SRSW to VDVSS	-0.3 V to VDVDD + 0.3 V
Digital Outputs to IOVSS	-0.3 V to IOVDD + 0.3 V
Digital Inputs to IOVSS	-0.3 V to IOVDD + 0.3 V
SCK, SL, SDATA to DVSS	-0.3 V to DVDD + 0.3 V
REFT, REFB, CCDIN to AVSS	-0.3 V to AVDD + 0.3 V
Junction Temperature	150°C
Lead Temperature (Soldering, 10 sec)	350°C

Stresses above those listed under Absolute Maximum Ratings may cause permanent damage to the device. This is a stress rating only; functional operation of the device at these or any other conditions above those indicated in the operational section of this specification is not implied. Exposure to absolute maximum rating conditions for extended periods may affect device reliability.

### THERMAL RESISTANCE

$\theta_{JA}$  is specified for the worst-case conditions, that is, a device soldered in a circuit board for surface-mount packages.

Table 7. Thermal Resistance

Package Type	$\theta_{JA}$	Unit
CSP_BGA (BC-105-1)	40.3	°C/W

### ESD CAUTION



**ESD (electrostatic discharge) sensitive device.** Charged devices and circuit boards can discharge without detection. Although this product features patented or proprietary protection circuitry, damage may occur on devices subjected to high energy ESD. Therefore, proper ESD precautions should be taken to avoid performance degradation or loss of functionality.

## PIN CONFIGURATION AND FUNCTION DESCRIPTIONS

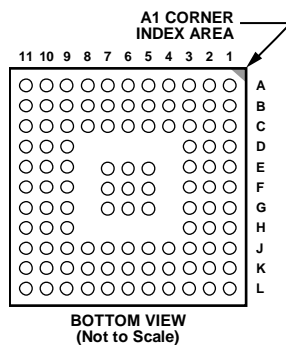

Figure 4. Pin Configuration

Table 8. Pin Function Descriptions

Pin No.	Mnemonic	Type <sup>1</sup>	Description
L6	AVDD	P	Analog Supply.
J7, K8	AVSS	P	Analog Supply Ground.
A10	DVDD	P	Digital Logic Supply.
A9	DVSS	P	Digital Logic Ground.
L5	CLIVDD	P	CLI Input Supply.
K6	TCVDD	P	Analog Timing Core Supply.
K4	TCVSS	P	Analog Timing Core Ground.
A2	DRVDD	P	Data Driver Supply.
B2	DRVSS/LDOVSS	P	Data Driver and LDO Ground.
E1	HVDD1	P	H-Driver Supply.
E2	HVSS1	P	H-Driver Ground.
G1	HVDD2	P	H-Driver Supply.
G2	HVSS2	P	H-Driver Ground.
J1	HVDD2	P	H-Driver Supply.
J2	HVSS2	P	H-Driver Ground.
L3	RGVDD	P	RG, HL Driver Supply.
K3	RGVSS	P	RG, HL Driver Ground.
B1	LDOIN	P	LDO 3.3 V Input.
C1	LDOOUT	P	LDO Output Voltage.
H11	IOVDD	P	Digital I/O Supply.
G11	IOVSS	P	Digital I/O Ground.
C11	VDVDD	P	V-Driver Logic Supply (3 V).
C10	VDVSS	P	V-Driver Ground.
E3	VM1	P	V-Driver Midsupply.
D3	VL1	P	V-Driver Low Supply.
C3	VH1	P	V-Driver High Supply.
J3	VH2	P	V-Driver High Supply.
H3	VL2	P	V-Driver Low Supply.
F3	VM2	P	V-Driver Midsupply.
G3	VMM	P	V-Driver Midsupply for SUBCK Output.
J4	VLL	P	V-Driver Low Supply for SUBCK Output.
L7	CCDIN	AI	CCD Signal Input.
K7	CCDGND	AI	CCD Ground.
C2	SRCTL	AI	Slew Rate Control Pin. Tie to VDVSS if not used.
L8	REFT	AO	Voltage Reference Top Bypass.
L9	REFB	AO	Voltage Reference Bottom Bypass.
D11	VD	DIO	Vertical Sync Pulse.
E10	HD	DIO	Horizontal Sync Pulse.

# AD9920A

Pin No.	Mnemonic	Type <sup>1</sup>	Description
E11	SYNC/RST	DO	SYNC Pin (Internal Pull-Up Resistor)/External Reset Input (Active Low).
K9	SL	DI	3-Wire Serial Load Pulse (Internal Pull-Up Resistor).
K10	SDATA	DI	3-Wire Serial Data.
L10	SCK	DI	3-Wire Serial Clock.
B11	VDR_EN	DI	Enable V-Outputs When High.
K11	XSUBCNT	DI	XSUBCNT Input to SUBCK Buffer.
C9	SRSW	DI	Slew Rate Control Enable. Tie to ground to disable.
J6	LEGEN	DI	Legacy Mode Enable Bar. Tie to ground for legacy 18-channel mode.
J5	CLI	DI	Reference Clock Input.
K5	CLO	DO	Clock Output for Crystal.
F10	GPO1	DO	General-Purpose Output.
H9	GPO2	DO	General-Purpose Output.
G10	GPO3	DO	General-Purpose Output.
F11	GPO4	DO	General-Purpose Output.
H10	GPO7	DO	General-Purpose Output.
J11	GPO8	DO	General-Purpose Output.
B9	D0	DO	Data Output (LSB).
C6	D1	DO	Data Output.
C7	D2	DO	Data Output.
A8	D3	DO	Data Output.
A7	D4	DO	Data Output.
B7	D5	DO	Data Output.
B6	D6	DO	Data Output.
A6	D7	DO	Data Output.
A5	D8	DO	Data Output.
B4	D9	DO	Data Output.
A4	D10	DO	Data Output.
A3	D11	DO	Data Output (MSB).
B3	DCLK	DO	Data Clock Output.
D1	H1	DO	CCD Horizontal Clock.
D2	H2	DO	CCD Horizontal Clock.
F1	H3	DO	CCD Horizontal Clock.
F2	H4	DO	CCD Horizontal Clock.
H1	H5	DO	CCD Horizontal Clock.
H2	H6	DO	CCD Horizontal Clock.
K1	H7	DO	CCD Horizontal Clock.
K2	H8	DO	CCD Horizontal Clock.
L2	HL	DO	CCD Horizontal Clock.
L4	RG	DO	CCD Reset Gate Clock.
G9	V1A	VO3	CCD Vertical Transfer Clock. Three-level output (XV1 + XV16).
G6	V1B	VO3	CCD Vertical Transfer Clock. Three-level output (XV1 + XV17).
G5	V2A	VO3	CCD Vertical Transfer Clock. Three-level output (XV2 + XV18).
E9	V2B	VO3	CCD Vertical Transfer Clock. Three-level output (XV2 + XV19).
J9	V3A	VO3	CCD Vertical Transfer Clock. Three-level output (XV3 + XV20).
F6	V3B	VO3	CCD Vertical Transfer Clock. Three-level output. $\overline{\text{LEGEN}}$ is low, XV3 + XV21. $\overline{\text{LEGEN}}$ is high, XV23 + XV21.
F5	V4	VO3	CCD Vertical Transfer Clock. Three-level output (XV4 + XV22).
E5	V5	VO3	CCD Vertical Transfer Clock. Three-level output. $\overline{\text{LEGEN}}$ is low, XV5 + XV23. $\overline{\text{LEGEN}}$ is high, XV5 + GPO5.
D10	V6	VO3	CCD Vertical Transfer Clock. Three-level output. $\overline{\text{LEGEN}}$ is low, XV6 + XV24. $\overline{\text{LEGEN}}$ is high, XV6 + GPO6.
F9	V7	VO2	CCD Vertical Transfer Clock. Two-level output (XV7).
F7	V8	VO2	CCD Vertical Transfer Clock. Two-level output (XV8).

Pin No.	Mnemonic	Type <sup>1</sup>	Description
D9	V9	VO2	CCD Vertical Transfer Clock. Two-level output (XV9).
C4	V10	VO2	CCD Vertical Transfer Clock. Two-level output (XV10).
C5	V11	VO2	CCD Vertical Transfer Clock. Two-level output (XV11).
B5	V12	VO2	CCD Vertical Transfer Clock. Two-level output (XV12).
E6	V13	VO2	CCD Vertical Transfer Clock. Two-level output (XV13).
E7	V14	VO2	CCD Vertical Transfer Clock. Two-level output (XV14).
C8	V15	VO2	CCD Vertical Transfer Clock. Two-level output (XV15).
J8	V16	VO2	CCD Vertical Transfer Clock. Two-level output (XV24). Available only when $\overline{\text{LEGEN}}$ is high (19-channel mode).
G7	SUBCK	VO3	CCD Substrate Clock Output.
A1, A11, B8, B10, J10, L1, L11	NC		Not Internally Connected.

<sup>1</sup> AI = analog input; AO = analog output; DI = digital input; DO = digital output; DIO = digital input/output; P = power; VO2 = vertical driver output, two-level; VO3 = vertical driver output, three-level.

## TYPICAL PERFORMANCE CHARACTERISTICS

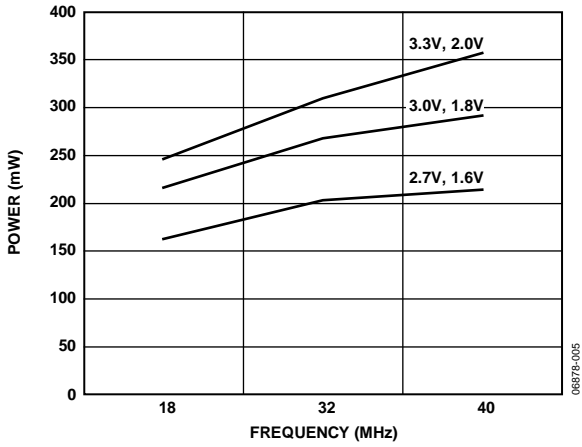

Figure 5. AFETG Power vs. Frequency (V-Driver Not Included);  
 $AVDD = TCVD = DVDD = 1.8V$ , All Other Supplies at 2.7V, 3.0V, or 3.3V

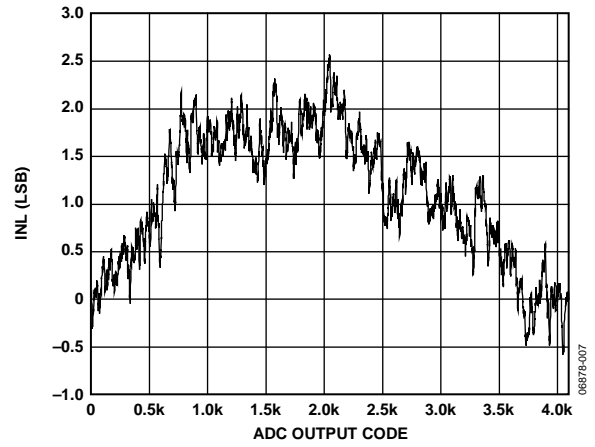

Figure 7. Typical System Integral Nonlinearity (INL) Performance

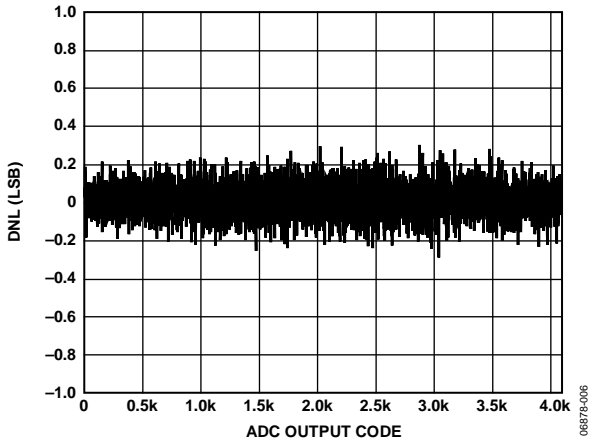

Figure 6. Typical Differential Nonlinearity (DNL) Performance

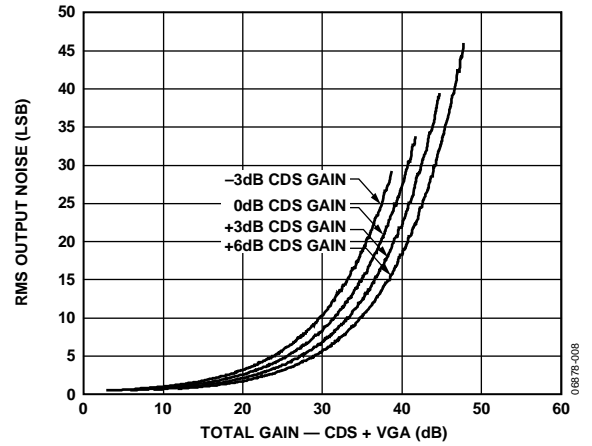

Figure 8. Output Noise vs. Total Gain (CDS + VGA)

# EQUIVALENT CIRCUITS

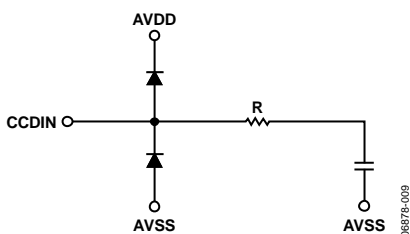

Figure 9. CCDIN

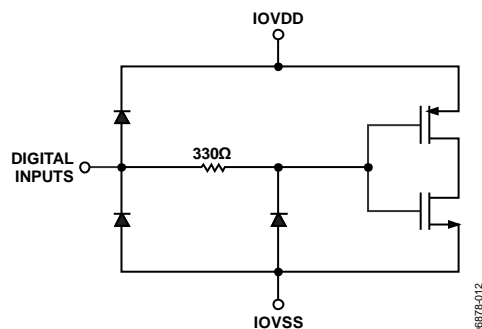

Figure 12. Digital Inputs

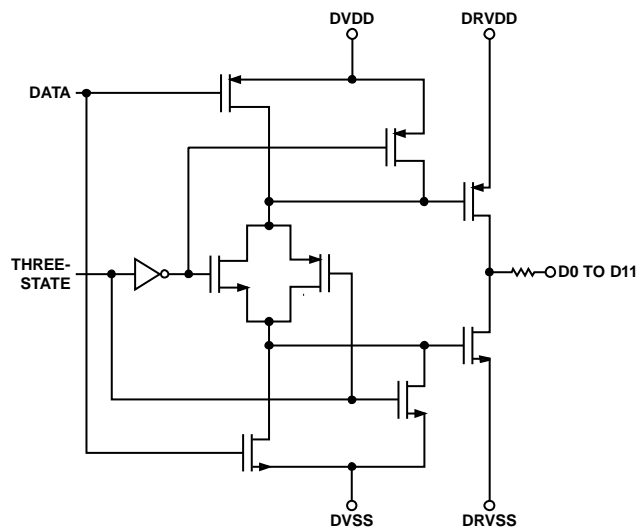

Figure 10. Digital Data Outputs

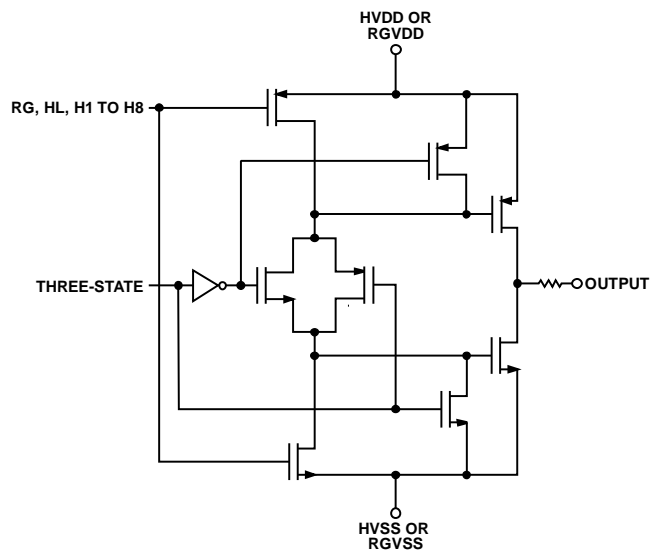

Figure 13. H1 to H8, HL, RG Drivers

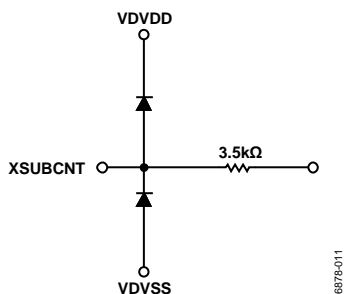

Figure 11. XSUBCNT

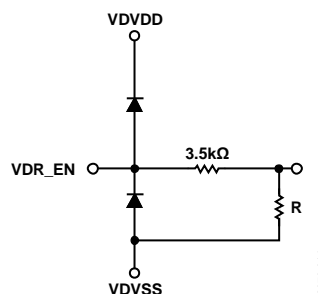

Figure 14. VDR\_EN

## TERMINOLOGY

### Differential Nonlinearity (DNL)

An ideal ADC exhibits code transitions that are exactly 1 LSB apart. DNL is the deviation from this ideal value. It is often specified in terms of resolution for which no missing codes are guaranteed. No missing codes guaranteed to 12-bit resolution indicates that all 4096 codes, each for its respective input, must be present over all operating conditions.

### Integral Nonlinearity (INL)

INL is defined as the maximum deviation of the actual analog output from the ideal output, determined by a straight line drawn from zero scale to full scale.

### Peak Nonlinearity

Peak nonlinearity, a full signal chain specification, refers to the peak deviation of the output of the AD9920A from a true straight line. The point used as zero scale occurs 0.5 LSB before the first code transition. Positive full scale is defined as a level 1 LSB and 0.5 LSB beyond the last code transition. The deviation is measured from the middle of each particular output code to the true straight line. The error is then expressed as a percentage of the 2 V ADC full-scale signal. The input signal is always appropriately amplified to fill the ADC full-scale range.

### Power Supply Rejection (PSR)

The PSR is measured with a step change applied to the supply pins. The PSR specification is calculated from the change in the data outputs for a given step change in the supply voltage.

### Total Output Noise

The rms output noise is measured using histogram techniques. The standard deviation of the ADC output codes is calculated in LSB and represents the rms noise level of the total signal chain at the specified gain setting. The output noise can be converted to an equivalent voltage using the relationship

$$1 \text{ LSB} = (\text{ADC Full Scale}/2^n \text{ Codes})$$

where  $n$  is the bit resolution of the ADC.

For the AD9920A, 1 LSB = 0.244 mV.

## THEORY OF OPERATION

Figure 15 shows the typical system block diagram for the AD9920A in master mode. The CCD output is processed by the AD9920A AFE circuitry, which consists of a CDS, black level clamp, and ADC. The digitized pixel information is sent to the digital image processor chip, which performs the postprocessing and compression. To operate the CCD, all CCD timing parameters are programmed into the AD9920A from the system microprocessor through the 3-wire serial interface. From the master clock, CLI, provided by the image processor or external crystal, the AD9920A generates the CCD horizontal and vertical clocks and the internal AFE clocks. External synchronization is provided by a sync pulse from the microprocessor, which resets the internal counters and resyncs the VD and HD outputs.

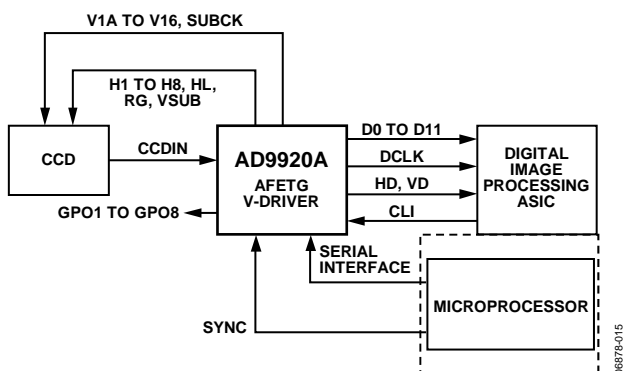

Figure 15. Typical System Block Diagram, Master Mode

Alternatively, the AD9920A can be operated in slave mode. In this mode, the VD and HD are provided externally from the image processor, and all AD9920A timing is synchronized with VD and HD.

The H-drivers for H1 to H8, HL, and RG are included in the AD9920A, allowing these clocks to be directly connected to the CCD. An H-driver voltage of up to 3.6 V is supported. V1A to V16 and SUBCK vertical clocks are included as well, allowing the AD9920A to provide all horizontal and vertical clocks necessary to clock data out of a CCD.

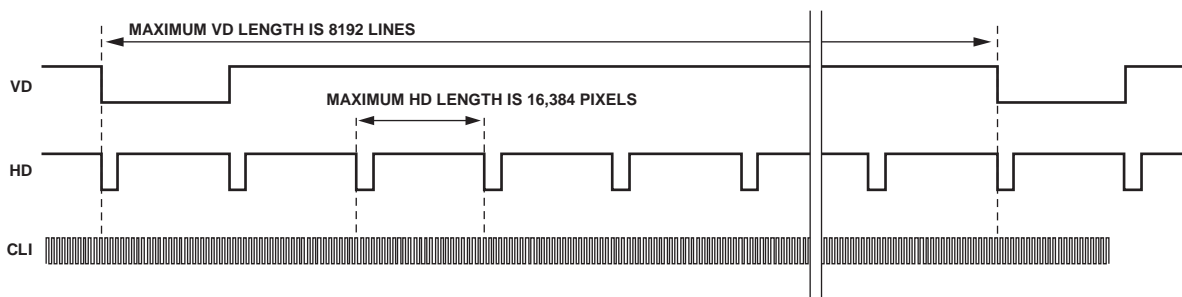

Figure 17. Maximum VD/HD Dimensions

The AD9920A includes programmable general-purpose outputs (GPOs) that can trigger mechanical shutter and strobe (flash) circuitry.

Figure 16 and Figure 17 show the maximum horizontal and vertical counter dimensions for the AD9920A. All internal horizontal and vertical clocking is controlled by these counters, which specify line and pixel locations. Maximum HD length is 16,384 pixels per line, and maximum VD length is 8192 lines per field.

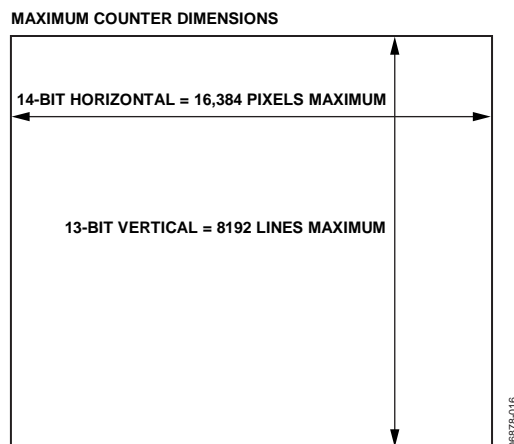

Figure 16. Vertical and Horizontal Counters

### H-COUNTER BEHAVIOR IN SLAVE MODE

In the AD9920A, the internal H-counter holds at its maximum count of 16,383 instead of rolling over. This feature allows the AD9920A to be used in applications that contain a line length greater than 16,384 pixels. Although no programming values for the vertical and horizontal signals are available beyond 8191, the H, RG, and AFE clocking continues to operate, sampling the remaining pixels on the line.

# AD9920A

## HIGH SPEED PRECISION TIMING CORE

The AD9920A generates high speed timing signals using the flexible *Precision Timing* core. This core is the foundation for generating the timing used for both the CCD and the AFE; it includes the reset gate (RG), horizontal drivers (H1 to H8, HL), and SHP/SHD sample clocks. A unique architecture makes it routine for the system designer to optimize image quality by providing precise control over the horizontal CCD readout and the AFE correlated double sampling.

The high speed timing of the AD9920A operates the same way in either master or slave mode configuration. For more information on synchronization and pipeline delays, see the Power-Up Sequence for Master Mode section.

### Timing Resolution

The *Precision Timing* core uses a 1× master clock input as a reference (CLI). This clock should be the same as the CCD pixel clock frequency. Figure 18 illustrates how the internal timing core

divides the master clock period into 64 steps or edge positions. Using a 40.5 MHz CLI frequency, the edge resolution of the *Precision Timing* core is approximately 0.4 ns. If a 1× system clock is not available, it is possible to use a 2× reference clock by programming the CLIDIVIDE register (AFE Register Address 0x0D). The AD9920A then internally divides the CLI frequency by 2.

### High Speed Clock Programmability

Figure 19 shows when the high speed clocks RG, H1 to H8, HL, SHP, and SHD are generated. The RG pulse has programmable rising and falling edges and can be inverted using the polarity control. Horizontal Clock H1 has programmable rising and falling edges and polarity control. In HCLK Mode 1, H3, H5, and H7 are equal to H1. H2, H4, H6, and H8 are always inverses of H1.

The edge location registers are each six bits wide, allowing the selection of all 64 edge locations. Figure 23 shows the default timing locations for all of the high speed clock signals.

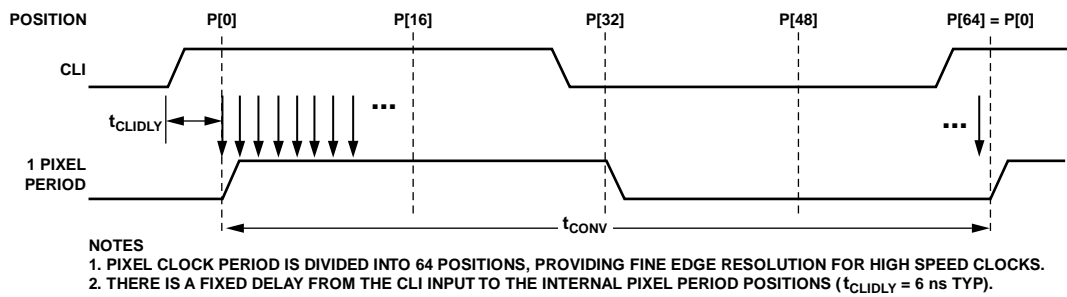

Figure 18. High Speed Clock Resolution from CLI, Master Clock Input

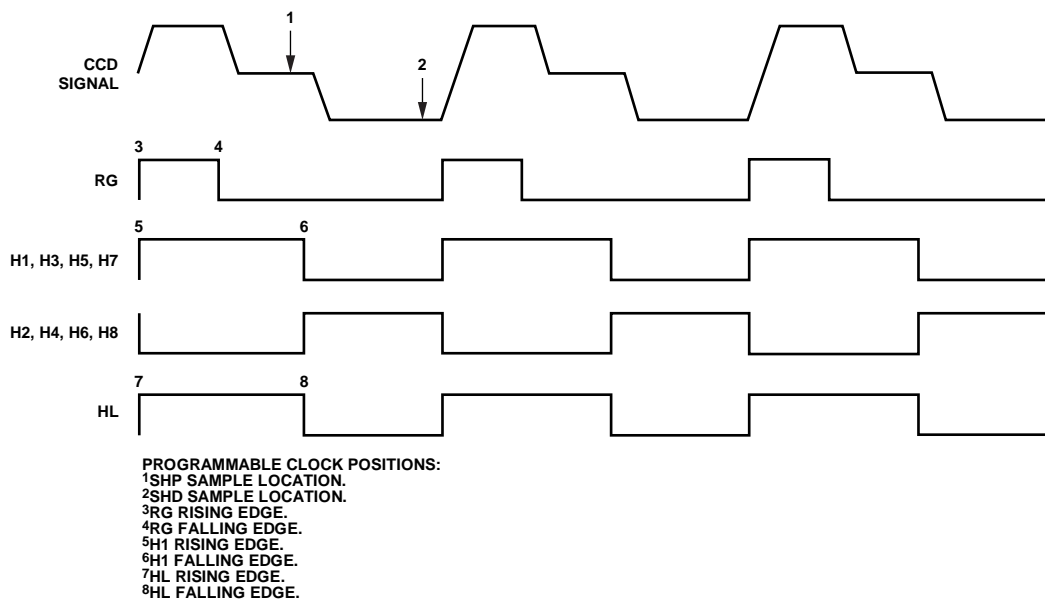

Figure 19. High Speed Clock Programmable Locations (HCLKMODE = 0x01)

### H-Driver and RG Outputs

In addition to the programmable timing positions, the AD9920A features on-chip output drivers for the RG, HL, and H1 to H8 outputs. These drivers are powerful enough to drive the CCD inputs directly. The H-driver and RG current can be adjusted for optimum rise/fall time for a particular load by using the drive strength control registers (Address 0x36 and Address 0x37). The 3-bit drive setting for each H1 to H8 output is adjustable in 4.3 mA increments: 0 = off, 1 = 4.3 mA, 2 = 8.6 mA, 3 = 12.9 mA, 4 = 17.3 mA, 5 = 21.6 mA, 6 = 25.9 mA, and 7 = 30.2 mA.

The 3-bit drive settings for the HL and RG outputs are also adjustable in 4.3 mA increments, but with a maximum drive strength of 17.3 mA: 0 = off, 1 = 4.3 mA, 2 = 8.6 mA, 3 = 12.9 mA, 4 = 4.3 mA, 5 = 8.6 mA, 6 = 12.9 mA, and 7 = 17.3 mA.

As shown in Figure 19, when HCLK Mode 1 is used, the H2, H4, H6, and H8 outputs are inverses of the H1, H3, H5, and H7 outputs. Using the HCLKMODE register (Address 0x24, Bits[4:0]), it is possible to select a different configuration.

Table 10 shows a comparison of the different programmable settings for each HCLK mode. Figure 20 and Figure 21 show the settings for HCLK Mode 2 and HCLK Mode 3, respectively.

It is recommended that all H1 to H8 outputs on the AD9920A be used together for maximum flexibility in drive strength settings. A typical CCD with H1 and H2 inputs should have only the AD9920A H1, H3, H5, and H7 outputs connected together to drive the CCD H1 and should have only the AD9920A H2, H4, H6, and H8 outputs connected together to drive the CCD H2.

In 3-phase HCLK mode, only six of the HCLK outputs are used, with two outputs driving each of the three phases:

- H1 and H2 are connected to CCD Phase 1.
- H5 and H6 are connected to CCD Phase 2.
- H7 and H8 are connected to CCD Phase 3.

**Table 9. Timing Core Register Parameters for H1, H2, HL, RG, SHP, and SHD**

Parameter	Length (Bits)	Range	Description
Positive Edge	6	0 to 63 edge location	Positive edge location for H1, H2, HL, H3P1, and RG.
Negative Edge	6	0 to 63 edge location	Negative edge location for H1, H2, HL, H3P1, and RG.
Sampling Location	6	0 to 63 edge location	Sampling location for internal SHP and SHD signals.
Drive Strength	3	0 to 7 current steps	Drive current for H1 to H8, HL, and RG outputs (4.3 mA per step).

**Table 10. HCLK Modes, Selected by Address 0x24, Bits[4:0]**

HCLKMODE	Register Value	Description
Mode 1	0x01	H1 edges are programmable with H3 = H5 = H7 = H1, H2 = H4 = H6 = H8 = inverse of H1.
Mode 2	0x02	H1 edges are programmable with H3 = H5 = H7 = H1. H2 edges are programmable with H4 = H6 = H8 = H2.
Mode 3	0x04	H1 edges are programmable with H3 = H1 and H2 = H4 = inverse of H1. H5 edges are programmable with H7 = H5 and H6 = H8 = inverse of H5.
3-Phase Mode	0x10	H1 edges are programmable using Address 0x33 and H2 = H1 (Phase 1). H5 edges are programmable using Address 0x31 and H6 = H5 (Phase 2). H7 edges are programmable using Address 0x30 and H8 = H7 (Phase 3).
Invalid Selection	All other values	Invalid register settings. Do not use.

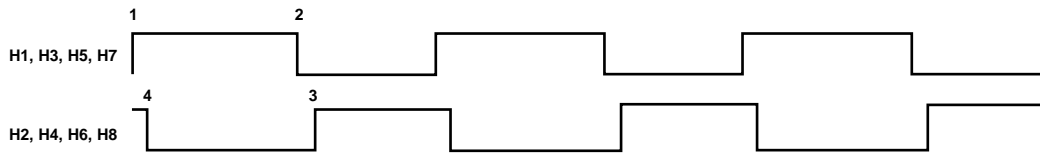

H1 TO H8 PROGRAMMABLE LOCATIONS:  
 1H1 RISING EDGE.  
 2H1 FALLING EDGE.  
 3H2 RISING EDGE.  
 4H2 FALLING EDGE.

Figure 20. HCLK Mode 2 Operation

06879-020

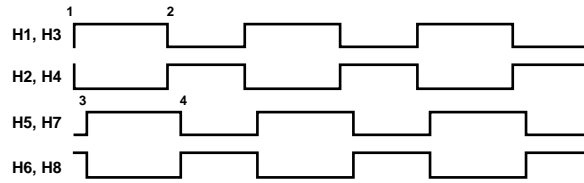

H1 TO H8 PROGRAMMABLE LOCATIONS:  
 1H1 RISING EDGE.  
 2H1 FALLING EDGE.  
 3H5 RISING EDGE.  
 4H5 FALLING EDGE.

Figure 21. HCLK Mode 3 Operation

06879-021

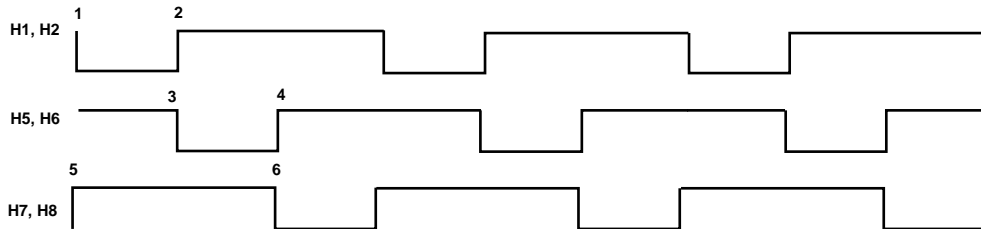

H1 TO H8 PROGRAMMABLE LOCATIONS:  
 1H1 FALLING EDGE.  
 2H1 RISING EDGE.  
 3H5 FALLING EDGE.  
 4H5 RISING EDGE.  
 5H7 RISING EDGE.  
 6H7 FALLING EDGE.

Figure 22. 3-Phase HCLK Mode Operation

06878-022

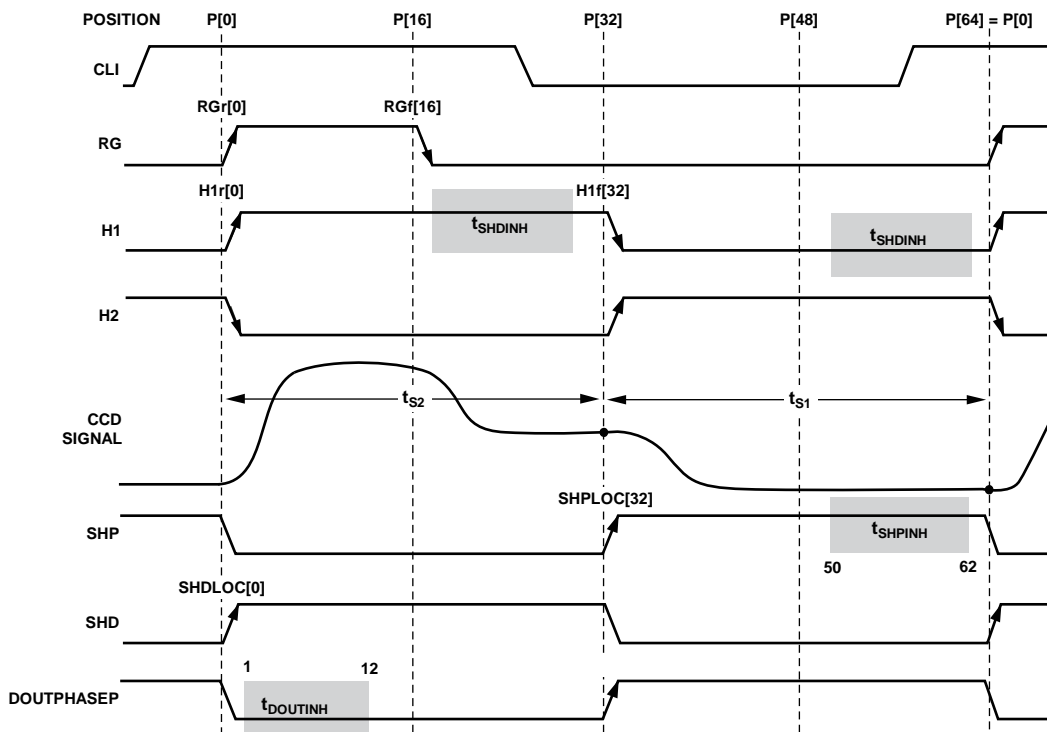

### NOTES

1. ALL SIGNAL EDGES ARE FULLY PROGRAMMABLE TO ANY OF THE 64 POSITIONS WITHIN ONE PIXEL PERIOD. TYPICAL POSITIONS FOR EACH SIGNAL ARE SHOWN. HCLK MODE 1 IS SHOWN.
2. CERTAIN POSITIONS SHOULD BE AVOIDED FOR EACH SIGNAL, SHOWN ABOVE AS INHIBIT REGIONS.
3. IF A SETTING IN THE INHIBIT REGION IS USED, AN UNSTABLE PIXEL SHIFT CAN OCCUR IN THE HBLK LOCATION OR AFE PIPELINE.
4. THE  $t_{SHPINH}$  AREA FROM 50 TO 62 ONLY APPLIES IN SLAVE MODE.
5. THE  $t_{SHDINH}$  AREA WILL APPLY TO EITHER H1 RISING OR FALLING EDGE, DEPENDING ON THE VALUE OF THE H1HBLK MASKING POLARITY.
6. THE  $t_{SHDINH}$  AREA CAN ALSO BE CHANGED TO A  $t_{SHPINH}$  AREA IF THE H1HBLKRETIME BIT = 1.

Figure 23. High Speed Timing Default Locations

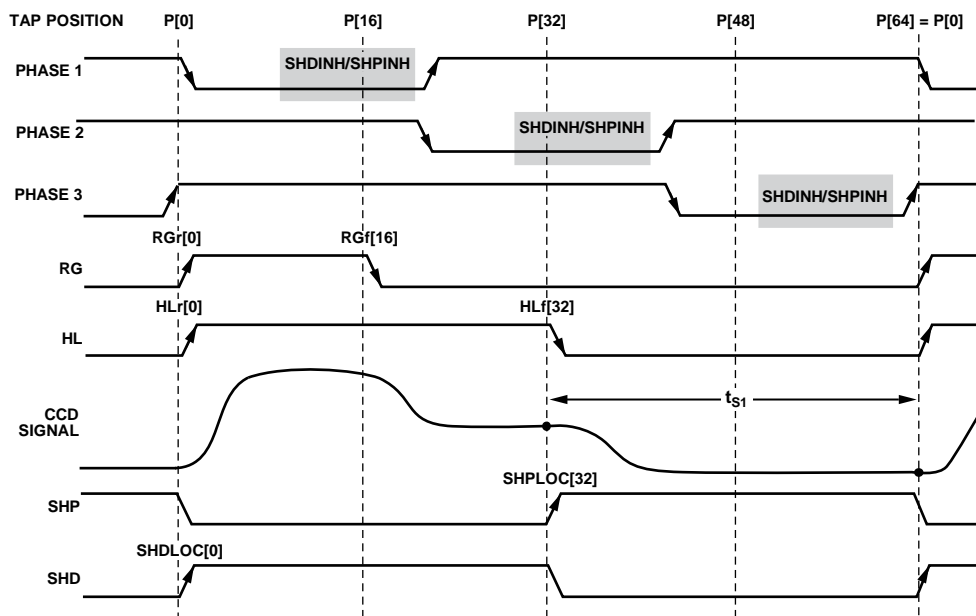

### NOTES

1. ALL SIGNAL EDGES ARE FULLY PROGRAMMABLE TO ANY OF THE 64 POSITIONS WITHIN ONE PIXEL PERIOD. TYPICAL POSITIONS FOR EACH SIGNAL ARE SHOWN USING 3-PHASE HCLK MODE.
2. THE RISING EDGE OF EACH HCLK PHASE HAS AN ASSOCIATED SHDINH.
3. WHEN THE HBLK RETIME BITS (0x35 [3:0]) ARE ENABLED, THE INHIBITED AREA BECOMES SHPINH.
4. WHEN THE HBLK MASK LEVEL FOR PHASE 1, 2, OR 3 IS CHANGED TO LOW, THE INHIBIT AREA IS REFERENCED TO THE HCLK FALLING EDGE, INSTEAD OF THE HCLK RISING EDGE.

Figure 24. High Speed Timing Typical Locations, 3-Phase HCLK Mode

## DIGITAL DATA OUTPUTS

The AD9920A data output and DCLK phase are programmable using the DOUTPHASE registers (Address 0x39, Bits[13:0]). DOUTPHASEP (Bits[5:0]) selects any edge location from 0 to 63, as shown in Figure 25. DOUTPHASEN (Bits[13:8]) does not actually program the phase of the data outputs but is used internally and should always be programmed to a value of DOUTPHASEP plus 32 edges. For example, if DOUTPHASEP is set to 0, DOUTPHASEN should be set to 32 (0x20).

Normally, the data output and DCLK signals track in phase, based on the contents of the DOUTPHASE registers. The DCLK output phase can also be held fixed with respect to the data outputs by setting the DCLKMODE register high (Address 0x39, Bit 16). In this mode, the DCLK output remains at a fixed phase equal to a delayed version of CLI, and the data output phase remains programmable.

The pipeline delay through the AD9920A is shown in Figure 26. After the CCD input is sampled by SHD, there is a 16-cycle delay until the data is available.

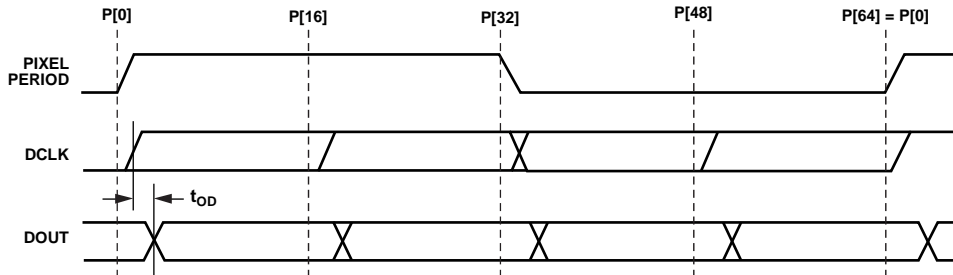

- NOTES**
1. DATA OUTPUT (DOUT) AND DCLK PHASE ARE ADJUSTABLE WITH RESPECT TO THE PIXEL PERIOD.
  2. WITHIN ONE CLOCK PERIOD, THE DATA TRANSITION CAN BE PROGRAMMED TO 64 DIFFERENT LOCATIONS.
  3. DCLK CAN BE INVERTED WITH RESPECT TO DOUT BY USING THE DCLKINV REGISTER.

06878-025

Figure 25. Digital Output Phase Adjustment Using DOUTPHASEP Register

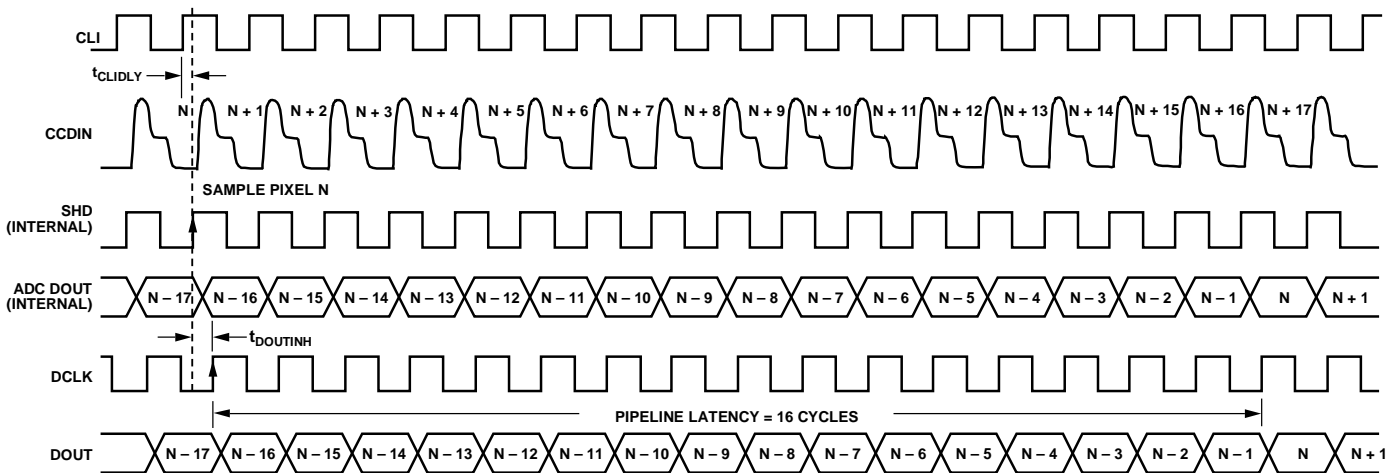

- NOTES**
1. TIMING VALUES SHOWN ARE SHDLOC = 0, WITH DCLKMODE = 0.
  2. HIGHER VALUES OF SHD AND/OR DOUTPHASE SHIFT DOUT TRANSITION TO THE RIGHT, WITH RESPECT TO CLI LOCATION.
  3. RECOMMENDED VALUE FOR DOUTPHASE IS TO USE SHPLOC OR UP TO 15 EDGES FOLLOWING SHPLOC.

Figure 26. Digital Data Output Pipeline Delay

06878-026

## HORIZONTAL CLAMPING AND BLANKING

The horizontal clamping and blanking pulses of the AD9920A are fully programmable to suit a variety of applications. Individual control is provided for CLPOB, PBLK, and HBLK in the different regions of each field. This allows the dark pixel clamping and blanking patterns to be changed at each stage of the readout to accommodate different image transfer timing and high speed line shifts.

### Individual CLPOB and PBLK Patterns

The AFE horizontal timing consists of CLPOB and PBLK, as shown in Figure 27. These two signals are programmed independently using the registers shown in Table 11. The start polarity for the CLPOB (or PBLK) signal is CLPOBPOL (PBLKPOL), and the first and second toggle positions of the pulse are CLPOBTOG1 (PBLKTOG1) and CLPOBTOG2 (PBLKTOG2). Both signals are active low and should be programmed accordingly.

A separate pattern for CLPOB and PBLK can be programmed for each vertical sequence. As described in the Vertical Timing Generation section, several V-sequences can be created, each containing a unique pulse pattern for CLPOB and PBLK.

Figure 57 shows how the sequence change positions divide the readout field into regions. By assigning a different V-sequence to each region, the CLPOB and PBLK signals can change with each change in the vertical timing.

### CLPOB and PBLK Masking Areas

Additionally, the AD9920A allows the CLPOB and PBLK signals to be disabled in certain lines in the field without changing any of the existing CLPOB pattern settings.

To use CLPOB (or PBLK) masking, the CLPMASKSTART (PBLKMASKSTART) and CLPMASKEND (PBLKMASKEND) registers are programmed to specify the start and end lines in the field where the CLPOB (PBLK) patterns are ignored. The three sets of start and end registers allow up to three CLPOB (PBLK) masking areas to be created.

The CLPOB and PBLK masking registers are not specific to a certain V-sequence; they are always active for any existing field of timing. During operation, to disable the CLPOB masking feature, these registers must be set to the maximum value of 0x1FFF or a value greater than the programmed VD length.

Note that to disable CLPOB (or PBLK) masking during power-up, it is recommended that CLPMASKSTART (PBLKMASKSTART) be set to 8191 and that CLPMASKEND (PBLKMASKEND) be set to 0. This prevents any accidental masking caused by register update events.

**Table 11. CLPOB and PBLK Pattern Registers**

Register	Length (Bits)	Range	Description
CLPOBPOL	1	High/low	Starting polarity of CLPOB for each V-sequence.
PBLKPOL	1	High/low	Starting polarity of PBLK for each V-sequence.
CLPOBTOG1	13	0 to 8191 pixel location	First CLPOB toggle position within line for each V-sequence.
CLPOBTOG2	13	0 to 8191 pixel location	Second CLPOB toggle position within line for each V-sequence.
PBLKTOG1	13	0 to 8191 pixel location	First PBLK toggle position within line for each V-sequence.
PBLKTOG2	13	0 to 8191 pixel location	Second PBLK toggle position within line for each V-sequence.
CLPMASKSTART	13	0 to 8191 line location	CLPOB masking area—starting line within field (maximum of three areas).
CLPMASKEND	13	0 to 8191 line location	CLPOB masking area—ending line within field (maximum of three areas).
PBLKMASKSTART	13	0 to 8191 line location	PBLK masking area—starting line within field (maximum of three areas).
PBLKMASKEND	13	0 to 8191 line location	PBLK masking area—ending line within field (maximum of three areas).

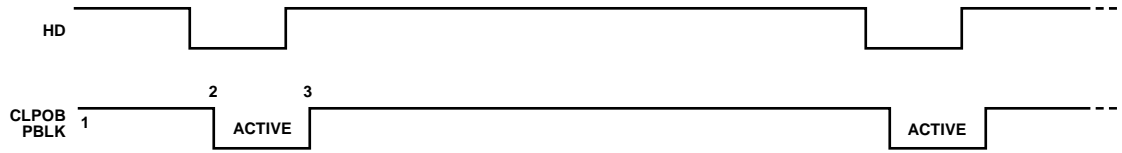

PROGRAMMABLE SETTINGS:  
<sup>1</sup>START POLARITY (CLAMP AND BLANK REGION ARE ACTIVE LOW).  
<sup>2</sup>FIRST TOGGLE POSITION.  
<sup>3</sup>SECOND TOGGLE POSITION.

06878-027

Figure 27. Clamp and Preblank Pulse Placement

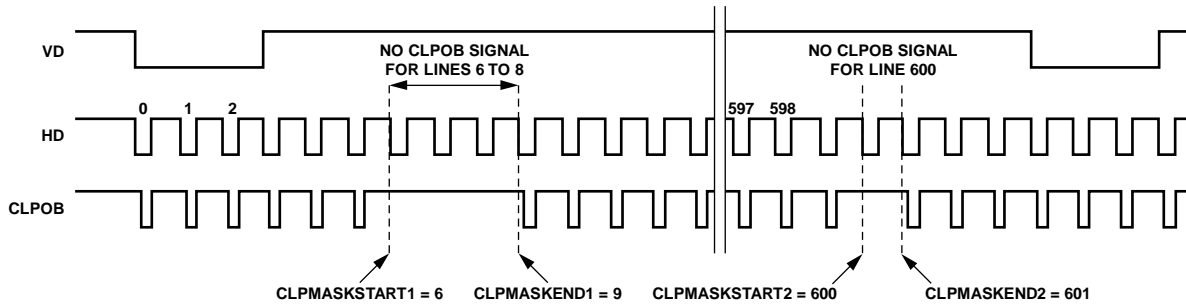

06878-028

Figure 28. CLPOB Masking Example

### Individual HBLK Patterns

The HBLK programmable timing shown in Figure 29 is similar to the timing of CLPOB and PBLK; however, there is no start polarity control. Only the toggle positions are used to designate the start and stop positions of the blanking period. Additionally, separate masking polarity controls for each H-clock phase designate the polarity of the horizontal clock signals during the blanking period. Setting HBLKMASK\_H1 high sets H1—and, therefore, H3, H5, and H7—low during the blanking, as shown in Figure 30. As with the CLPOB and PBLK signals, HBLK registers are available in each V-sequence, allowing different blanking signals to be used with different vertical timing sequences.

The AD9920A supports two modes of HBLK operation. HBLK Mode 0 supports basic operation and pixel mixing HBLK operation. HBLK Mode 1 supports advanced HBLK operation.

The following sections describe each mode in detail. Register parameters are described in detail in Table 12.

### HBLK Mode 0 Operation

There are six toggle positions available for HBLK. Normally, only two of the toggle positions are used to generate the standard HBLK interval. However, the additional toggle positions can be used to generate special HBLK patterns, as shown in Figure 31. The pattern in this example uses all six toggle positions to generate two extra groups of pulses during the HBLK interval. By changing the toggle positions, different patterns can be created.

Separate toggle positions are available for even and odd lines. If alternation is not needed, the same values should be loaded into the registers for even (HBLKTOGE) and odd (HBLKTOGO) lines.

Multiple repeats of the HBLK signal are enabled by setting the HBLKLEN and HBLKREP registers along with the six toggle positions (four are shown in Figure 32).

### Generating HBLK Line Alternation

HBLK Mode 0 provides the ability to alternate different HBLK toggle positions on even and odd lines. HBLK line alternation can be used alone or in conjunction with V-pattern odd/even alternation (see the Generating Line Alternation for V-Sequences and HBLK section). Separate toggle positions are available for even and odd lines. If even/odd line alternation is not needed, the same values should be loaded into the registers for even (HBLKTOGE) and odd (HBLKTOGO) lines.

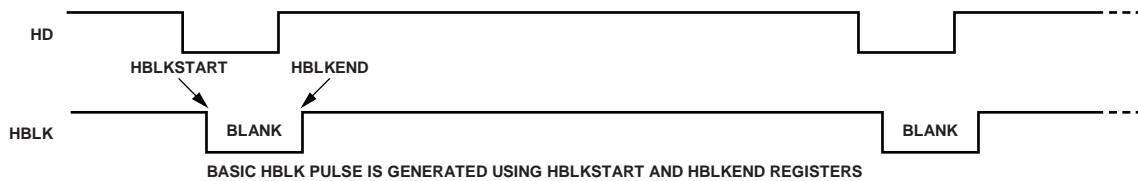

Figure 29. Typical Horizontal Blanking Pulse Placement (HBLK\_MODE = 0)

06876-116

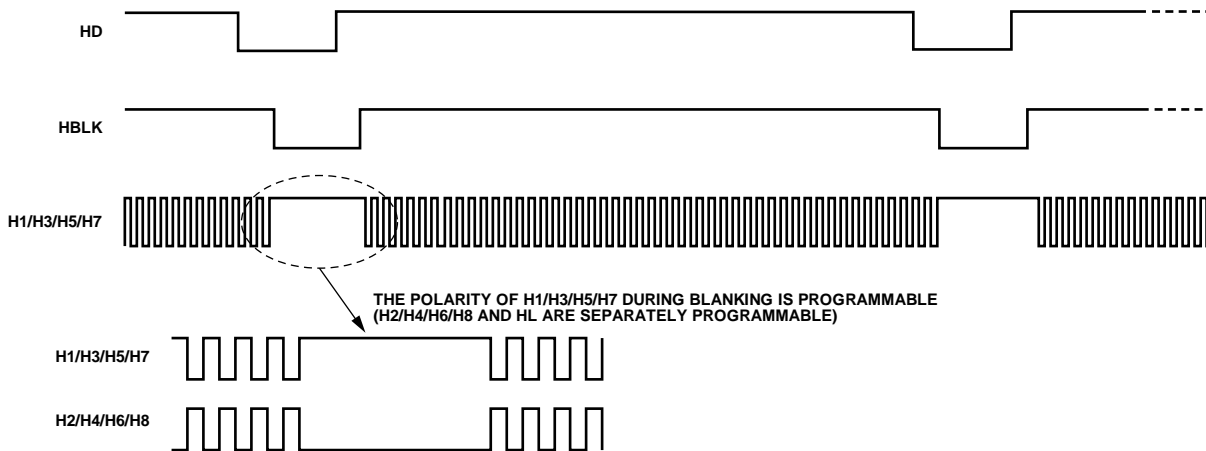

Figure 30. HBLK Masking Polarity Control

06876-029

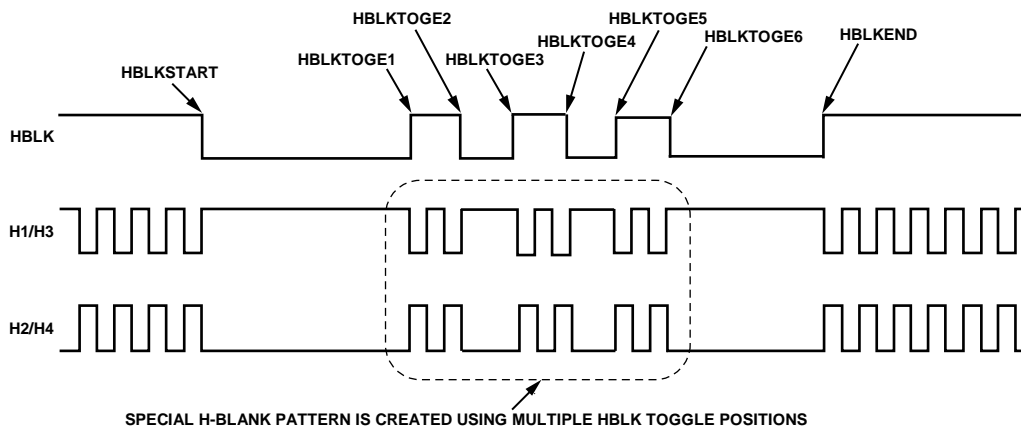

Figure 31. Using Multiple Toggle Positions for HBLK (HBLK\_MODE = 0)

06876-030

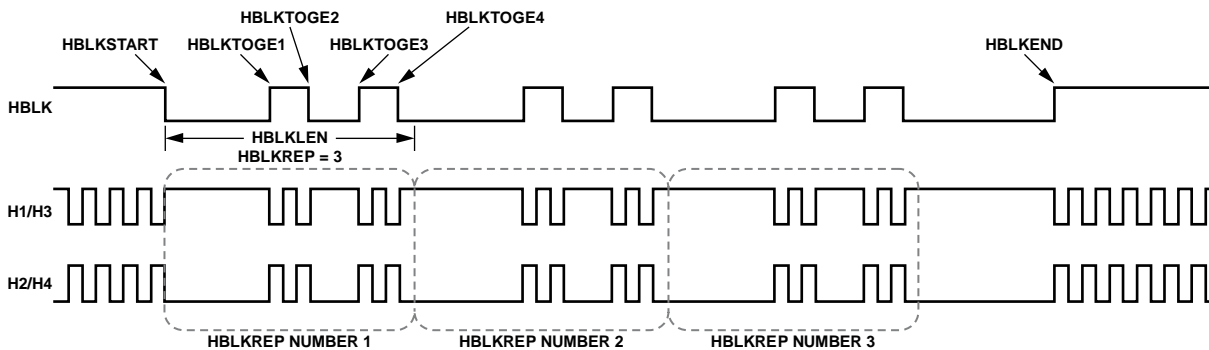

Figure 32. HBLK Repeating Pattern Using HBLK\_MODE = 0

06876-031

# AD9920A

**Table 12. HBLK Pattern Registers**

Register	Length (Bits)	Range	Description
HBLK_MODE	2	0 to 1 HBLK modes	Enables different HBLK toggle position operations. 0 = normal mode; six toggle positions available for even and odd lines. If even/odd alternation is not needed, set toggles for even and odd lines to the same value. In addition to the six toggle positions, the HBLKSTART, HBLKEND, HBLKLEN, and HBLKREP registers can be used to generate HBLK patterns. If even/odd alternation is not needed, set toggles for even and odd lines to the same value. 1 = advanced HBLK mode; divides HBLK interval into six repeat areas. Uses HBLKSTARTA/B/C and RAXHxREPA/B/C registers; the latter, depending on the mode of operation, are stored in the HBLKTOGO1 to HBLKTOGO6 and HBLKTOGE1 to HBLKTOGE6 registers (Address 0x19 to Address 0x1E; see Table 63). 2 = test mode only; do not access. 3 = test mode only; do not access.
HBLKSTART	13	0 to 8191 pixel location	Start location for HBLK in HBLK Mode 0 and HBLK Mode 1.
HBLKEND	13	0 to 8191 pixel location	End location for HBLK in HBLK Mode 0 and HBLK Mode 1.
HBLKLEN	13	0 to 8191 pixels	HBLK length in HBLK Mode 0 and HBLK Mode 1.
HBLKREP	13	0 to 8191 repetitions	Number of HBLK repetitions in HBLK Mode 0 and HBLK Mode 1.
HBLKMASK_H1	1	High/low	Masking polarity for H1/H3/H5/H7 during HBLK.
HBLKMASK_H2	1	High/low	Masking polarity for H2/H4/H6/H8 during HBLK.
HBLKMASK_HL	1	High/low	Masking polarity for HL during HBLK.
HBLKMASK_H3P	1	High/low	Masking polarity for H3P during 3-phase mode during HBLK.
HBLKTOGO1	13	0 to 8191 pixel location	First HBLK toggle position for odd lines in HBLK Mode 0.
HBLKTOGO2	13	0 to 8191 pixel location	Second HBLK toggle position for odd lines in HBLK Mode 0.
HBLKTOGO3	13	0 to 8191 pixel location	Third HBLK toggle position for odd lines in HBLK Mode 0.
HBLKTOGO4	13	0 to 8191 pixel location	Fourth HBLK toggle position for odd lines in HBLK Mode 0.
HBLKTOGO5	13	0 to 8191 pixel location	Fifth HBLK toggle position for odd lines in HBLK Mode 0.
HBLKTOGO6	13	0 to 8191 pixel location	Sixth HBLK toggle position for odd lines in HBLK Mode 0.
HBLKTOGE1	13	0 to 8191 pixel location	First HBLK toggle position for even lines in HBLK Mode 0.
HBLKTOGE2	13	0 to 8191 pixel location	Second HBLK toggle position for even lines in HBLK Mode 0.
HBLKTOGE3	13	0 to 8191 pixel location	Third HBLK toggle position for even lines in HBLK Mode 0.
HBLKTOGE4	13	0 to 8191 pixel location	Fourth HBLK toggle position for even lines in HBLK Mode 0.
HBLKTOGE5	13	0 to 8191 pixel location	Fifth HBLK toggle position for even lines in HBLK Mode 0.
HBLKTOGE6	13	0 to 8191 pixel location	Sixth HBLK toggle position for even lines in HBLK Mode 0.
RA0H1REPA/B/C	12	0 to 15 HCLK pulses for each A, B, and C	HBLK Repeat Area 0. Number of H1 repetitions for HBLKSTARTA/B/C in HBLK Mode 1 for even lines; odd lines defined using HBLKALT_PAT. Bits[3:0]: RA0H1REPA. Number of H1 pulses following HBLKSTARTA. Bits[7:4]: RA0H1REPB. Number of H1 pulses following HBLKSTARTB. Bits[11:8]: RA0H1REPC. Number of H1 pulses following HBLKSTARTC.
RA1H1REPA/B/C	12	0 to 15 HCLK pulses	HBLK Repeat Area 1. Number of H1 repetitions for HBLKSTARTA/B/C.
RA2H1REPA/B/C	12	0 to 15 HCLK pulses	HBLK Repeat Area 2. Number of H1 repetitions for HBLKSTARTA/B/C.
RA3H1REPA/B/C	12	0 to 15 HCLK pulses	HBLK Repeat Area 3. Number of H1 repetitions for HBLKSTARTA/B/C.
RA4H1REPA/B/C	12	0 to 15 HCLK pulses	HBLK Repeat Area 4. Number of H1 repetitions for HBLKSTARTA/B/C.
RA5H1REPA/B/C	12	0 to 15 HCLK pulses	HBLK Repeat Area 5. Number of H1 repetitions for HBLKSTARTA/B/C.
RA0H2REPA/B/C	12	0 to 15 HCLK pulses for each A, B, and C	HBLK Repeat Area 0. Number of H2 repetitions for HBLKSTARTA/B/C in HBLK Mode 1 for even lines; odd lines defined using HBLKALT_PAT. Bits[3:0]: RA0H2REPA. Number of H2 pulses following HBLKSTARTA. Bits[7:4]: RA0H2REPB. Number of H2 pulses following HBLKSTARTB. Bits[11:8]: RA0H2REPC. Number of H2 pulses following HBLKSTARTC.
RA1H2REPA/B/C	12	0 to 15 HCLK pulses	HBLK Repeat Area 1. Number of H2 repetitions for HBLKSTARTA/B/C.
RA2H2REPA/B/C	12	0 to 15 HCLK pulses	HBLK Repeat Area 2. Number of H2 repetitions for HBLKSTARTA/B/C.
RA3H2REPA/B/C	12	0 to 15 HCLK pulses	HBLK Repeat Area 3. Number of H2 repetitions for HBLKSTARTA/B/C.
RA4H2REPA/B/C	12	0 to 15 HCLK pulses	HBLK Repeat Area 4. Number of H2 repetitions for HBLKSTARTA/B/C.
RA5H2REPA/B/C	12	0 to 15 HCLK pulses	HBLK Repeat Area 5. Number of H2 repetitions for HBLKSTARTA/B/C.

Register	Length (Bits)	Range	Description
HBLKSTARTA	13	0 to 8191 pixel location	HBLK Repeat Area Start Position A for HBLK Mode 1. Set to 8191 if not used.
HBLKSTARTB	13	0 to 8191 pixel location	HBLK Repeat Area Start Position B for HBLK Mode 1. Set to 8191 if not used.
HBLKSTARTC	13	0 to 8191 pixel location	HBLK Repeat Area Start Position C for HBLK Mode 1. Set to 8191 if not used.
HBLKALT_PAT0	3	0 to 5 even repeat area	HBLK Mode 1, Repeat Area 0 pattern for odd lines. Selected from previously defined even line repeat areas.
HBLKALT_PAT1	3	0 to 5 even repeat area	HBLK Mode 1, Repeat Area 1 pattern for odd lines.
HBLKALT_PAT2	3	0 to 5 even repeat area	HBLK Mode 1, Repeat Area 2 pattern for odd lines.
HBLKALT_PAT3	3	0 to 5 even repeat area	HBLK Mode 1, Repeat Area 3 pattern for odd lines.
HBLKALT_PAT4	3	0 to 5 even repeat area	HBLK Mode 1, Repeat Area 4 pattern for odd lines.
HBLKALT_PAT5	3	0 to 5 even repeat area	HBLK Mode 1, Repeat Area 5 pattern for odd lines.

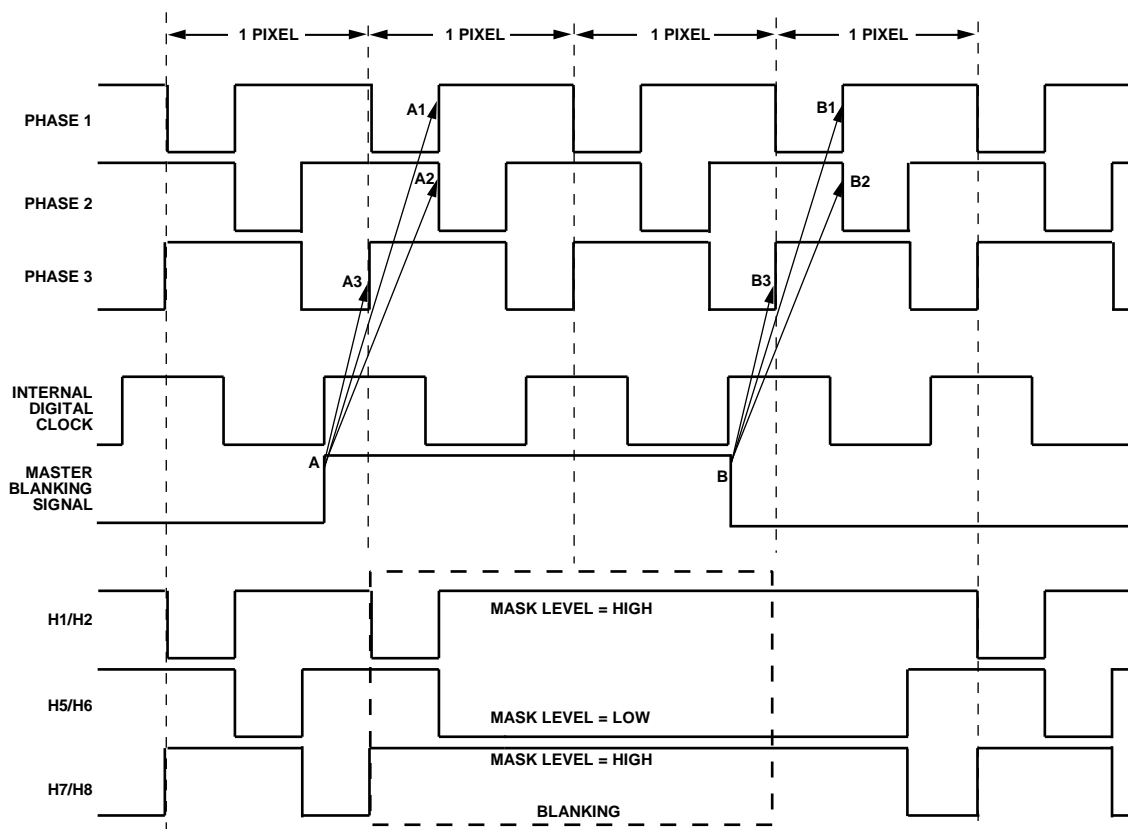

Figure 33. Example of Correct HBLK Behavior

06878-032

### HBLK Fine Retime Control

An additional set of register bits is available for use during 3-phase HCLK mode to provide fine adjustment of each HCLK phase during the HBLK interval. The fine retime bits (Address 0x35, Bits[23:20]) allow for the adjustment of the correct number of HCLK cycles during the HBLK interval.

Figure 33 through Figure 35 show the different settings that can be used based on the location of the HBLK toggle positions, the location of the internal digital clock, and the masking polarity of the different HCLK phases. By using the fine retime bits, the exact pulse behavior for each HCLK phase can be generated.

Figure 33 shows the desired HBLK behavior for all three phases when the internal digital clock is located before the Phase 3 rising edge. Figure 34 shows the effect of changing the internal clock phase (changing SHDLOC) to a different location. This causes incorrect blanking on Phase 1 and Phase 2.

Figure 35 shows how the fine retime bits for Phase 1 and Phase 2 are used to generate the correct blanking behavior, matching the result shown in Figure 33.

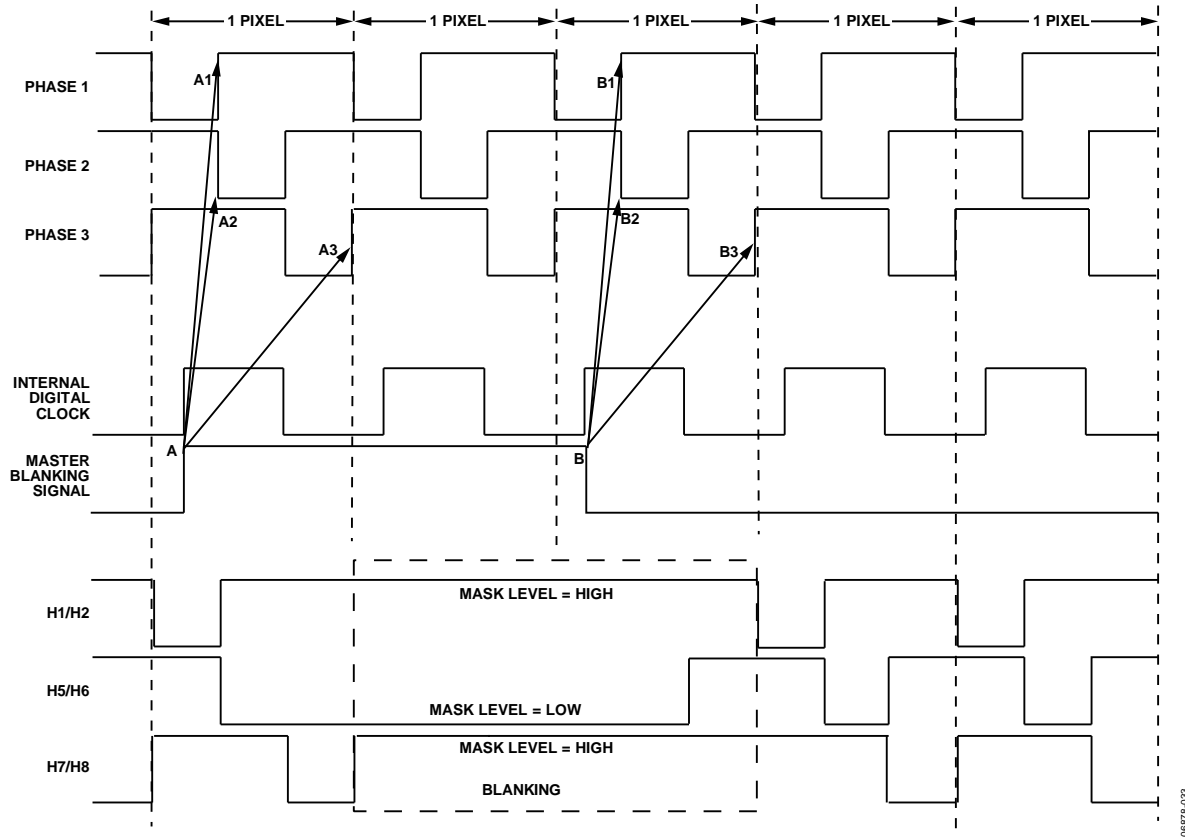

Figure 34. Incorrect HBLK Behavior Caused by Internal Clock Position

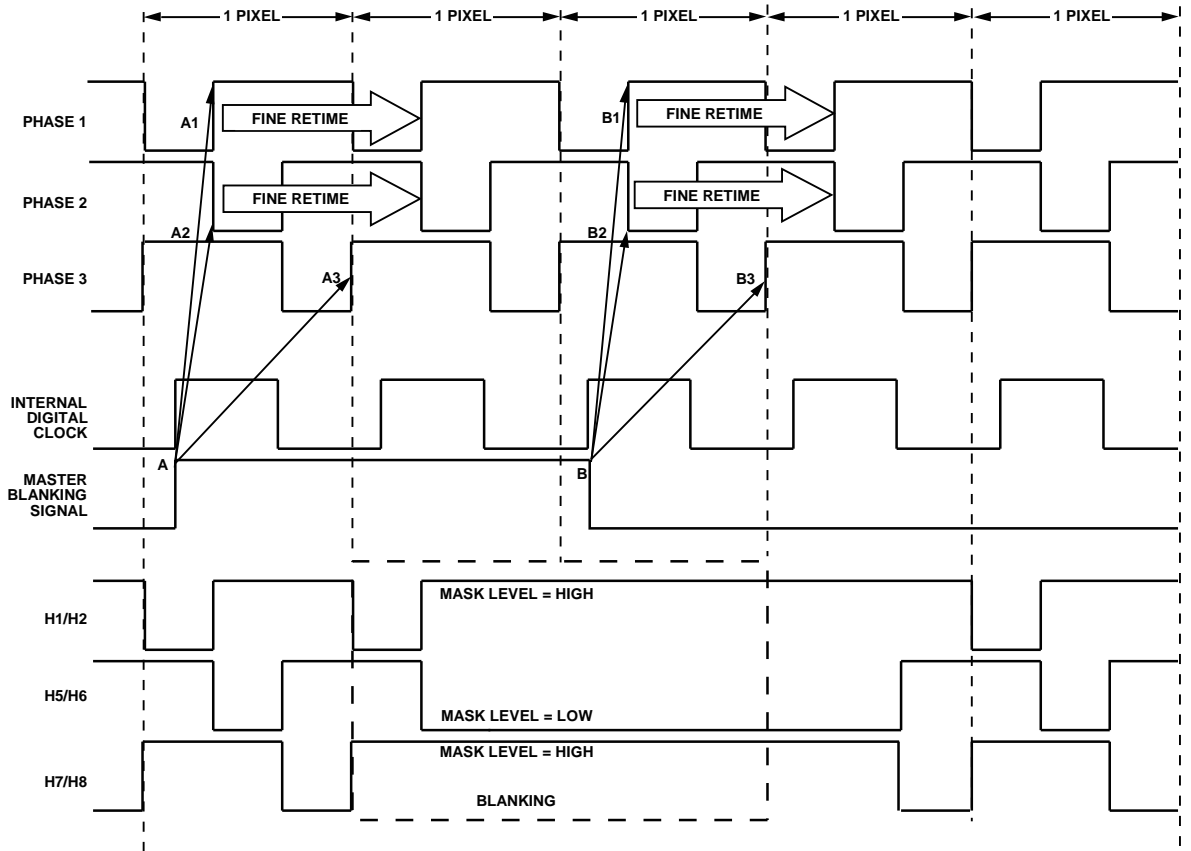

Figure 35. Fine Retime on Phase 2 to Achieve Correct HBLK

### Increasing H-Clock Width During HBLK

The AD9920A allows the H1 to H8 pulse width to be increased during the HBLK interval. As shown in Figure 36, the H-clock frequency can be reduced by a factor of 1/2, 1/4, 1/6, 1/8, 1/10, 1/12, and so on, up to 1/30. To enable this feature, the HCLK\_WIDTH register (Address 0x35, Bits[7:4]) is set to a value between 1 and 15. When this register is set to 0, the wide HCLK feature is disabled. The reduced frequency occurs for only the H1 to H8 pulses that are located within the HBLK area.

The HCLK\_WIDTH register is generally used in conjunction with special HBLK patterns to generate vertical and horizontal mixing in the CCD.

### HBLK Mode 1 Operation

HBLK Mode 1 allows more advanced HBLK pattern operation. If multiple areas of HCLK pulses that are unevenly spaced from one another are needed, HBLK Mode 1 can be used. Using a separate set of registers, HBLK Mode 1 can divide the HBLK region into up to six repeat areas (see Table 12).

As shown in Figure 37, each repeat area shares a common group of toggle positions: HBLKSTARTA, HBLKSTARTB, and HBLKSTARTC. However, the number of toggles following a start position can be unique in each repeat area by using the RAXH1REP and RAXH2REP registers; these registers, depending on the mode of operation, are stored in the HBLKTOGO1 to HBLKTOGO6 and HBLKTOGE1 to HBLKTOGE6 registers (Address 0x19 to Address 0x1E; see Table 63).

Table 13. HCLK Width Register

Register	Length (Bits)	Description
HCLK_WIDTH	4	Controls the H1 to H8 pulse widths during HBLK as a fraction of pixel rate 0 = same frequency as pixel rate; 1 = 1/2 pixel frequency (doubles the HCLK pulse width); 2 = 1/4 pixel frequency; 3 = 1/6 pixel frequency; 4 = 1/8 pixel frequency; 5 = 1/10 pixel frequency; 15 = 1/30 pixel frequency

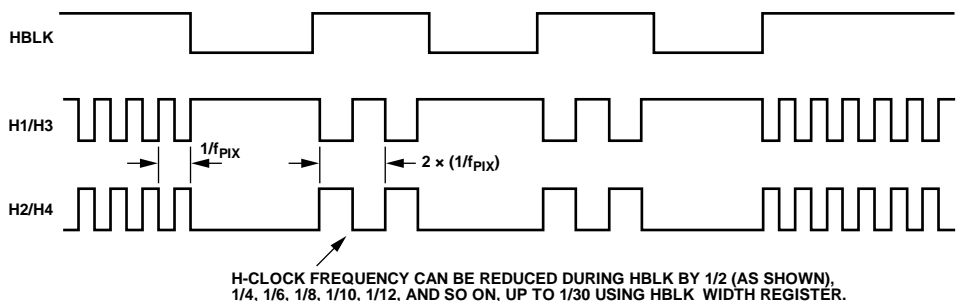

Figure 36. Generating Wide H-Clock Pulses During HBLK Interval

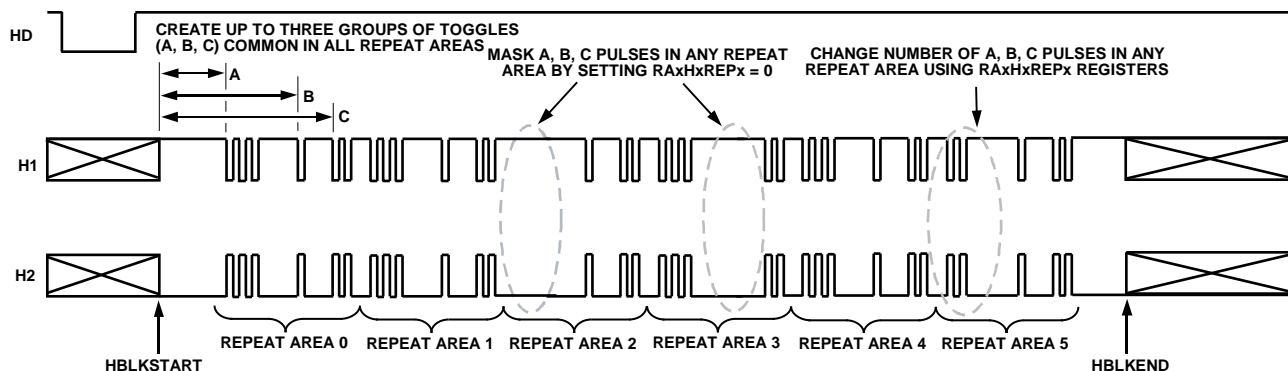

Figure 37. HBLK Mode 1 Registers



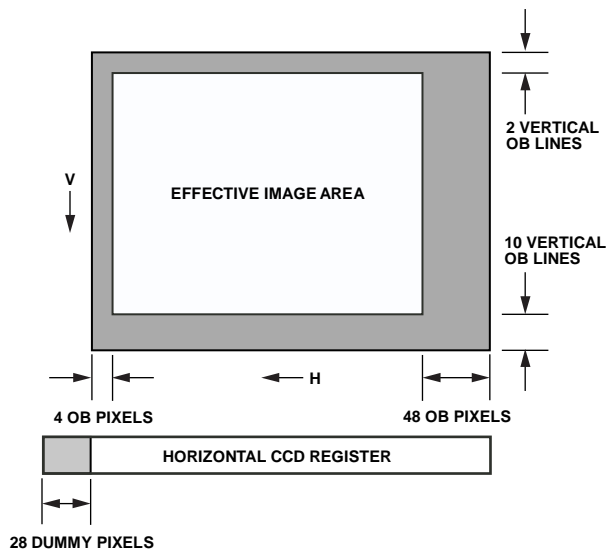
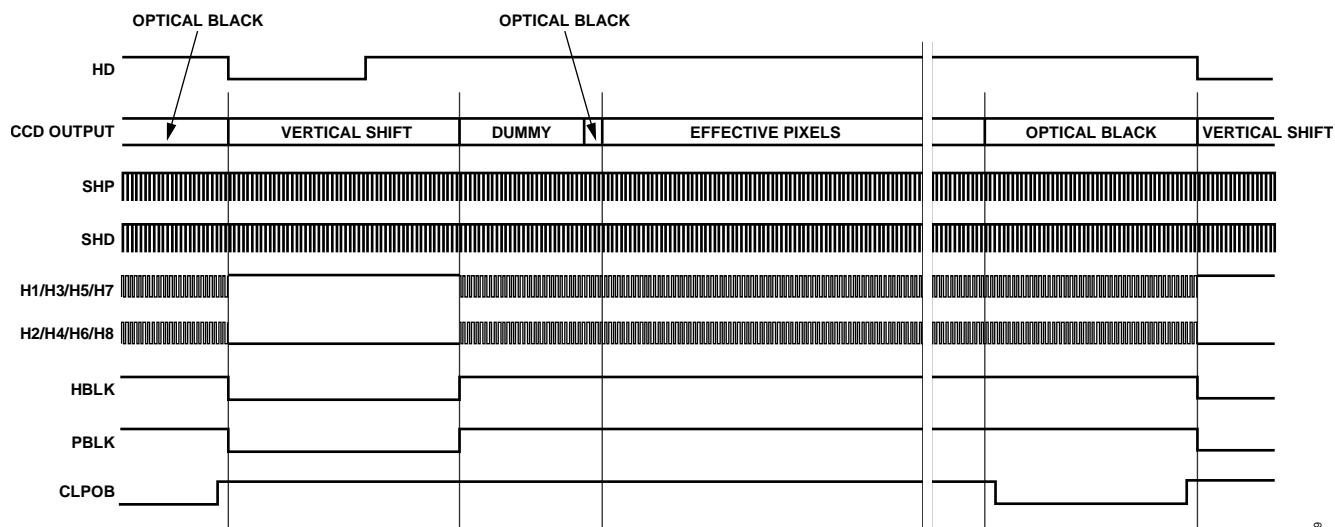

Figure 39. Example CCD Configuration

08879-038



NOTES  
1. PBLK ACTIVE (LOW) SHOULD NOT BE USED DURING CLPOB ACTIVE (LOW).

Figure 40. Horizontal Sequence Example

08879-038

## VERTICAL TIMING GENERATION

The AD9920A provides a flexible solution for generating vertical CCD timing and can support multiple CCDs and different system architectures. The vertical transfer clocks are used to shift each line of pixels into the horizontal output register of the CCD. The AD9920A allows these outputs to be individually programmed into various readout configurations by using a four-step process.

Figure 41 shows an overview of how the vertical timing is generated in four steps.

1. The individual pulse patterns for XV1 to XV24 are created by using the vertical pattern group registers.

2. The V-pattern groups are used to build the V-sequences where additional information is added.
3. The readout for an entire field is constructed by dividing the field into regions and then assigning a sequence to each region. Each field can contain up to nine different regions to accommodate the various steps of the readout, such as high speed line shifts and unique vertical line transfers. The total number of V-patterns, V-sequences, and fields is programmable but limited by the number of registers.
4. The mode registers allow the different fields to be combined in any order for various readout configurations.

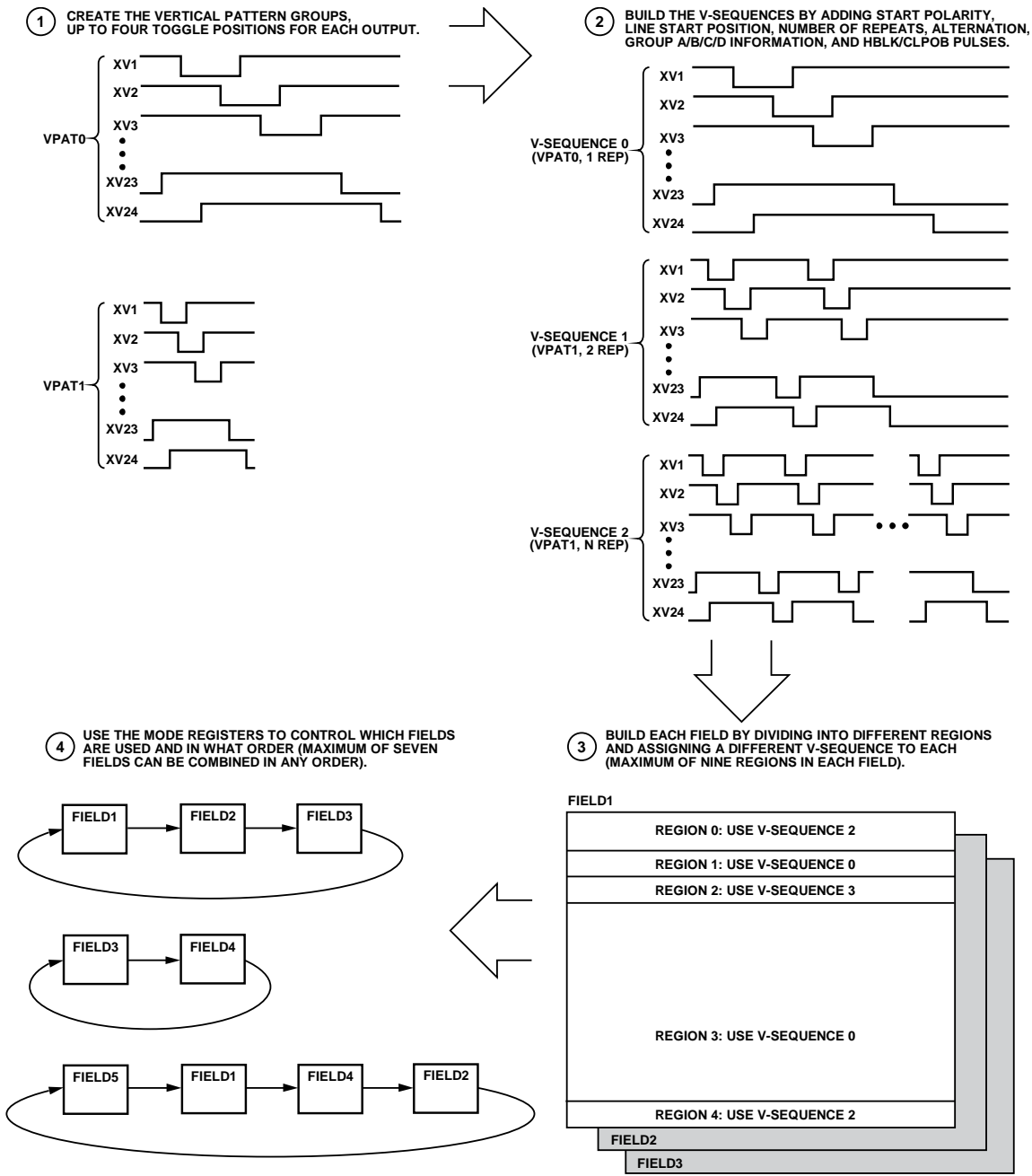

Figure 41. Summary of Vertical Timing Generation

06B7E-040

**Vertical Pattern Groups (VPAT)**

The vertical pattern groups define the individual pulse patterns for each XV1 to XV24 output signal. Table 14 summarizes the registers available for generating each V-pattern group. The first, second, third, and fourth toggle positions (VTOG1, VTOG2, VTOG3, and VTOG4) are the pixel locations within the line where the pulse transitions. All toggle positions are 13-bit values, allowing their placement anywhere in the first 8191 pixels of the line.

More registers are included in the vertical sequence registers to specify the output pulses. VPOL specifies the start polarity for each signal; VSTART specifies the start position of the V-pattern group within the line; VLEN designates the total length of the V-pattern group, which determines the number of pixels between each of the pattern repetitions when repetitions are used.

The VSTART position is actually an offset value for each toggle position. The actual pixel location for each toggle, measured from the HD falling edge (Pixel 0), is equal to the VSTART value plus the toggle position.

When the selected V-output is designated as a VSG pulse, either the VTOG1/VTOG2 or VTOG3/VTOG4 pair is selected using V-Sequence Address 0x03, VSGPATSEL. All four toggle positions are not simultaneously available for VSG pulses.

All unused V-channels must have their toggle positions programmed to either 0 or maximum value. This prevents unpredictable behavior because the default values of the V-pattern group registers are unknown.

**Table 14. Vertical Pattern Group Registers**

Register	Length (Bits)	Description
VTOG1	13	First toggle position within the line for each XV1 to XV24 output, relative to VSTART value.
VTOG2	13	Second toggle position, relative to VSTART value.
VTOG3	13	Third toggle position, relative to VSTART value.
VTOG4	13	Fourth toggle position, relative to VSTART value.

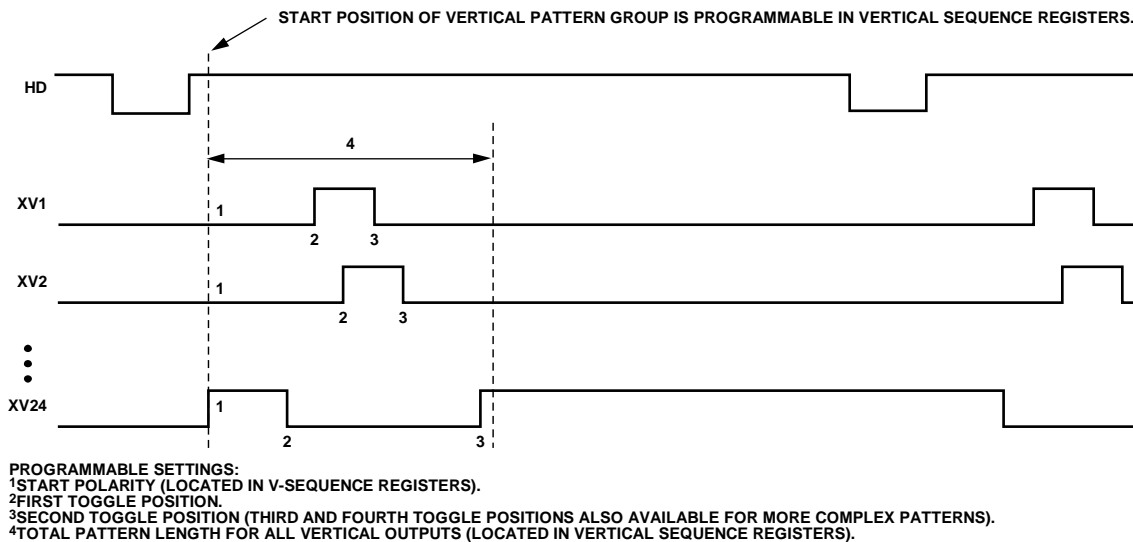

Figure 42. Vertical Pattern Group Programmability

06878-041

## VERTICAL SEQUENCES (VSEQ)

The vertical sequences are created by selecting one of the V-pattern groups and adding repeats, start position, horizontal clamping, and blanking information. The V-sequences are programmed using the registers shown in Table 15. Figure 43 shows an example of how these registers are used to generate the V-sequences.

The VPATSELA, VPATSELB, VPATSELC, and VPATSELD registers select which V-pattern is used in a given V-sequence. Having four groups available allows each vertical output to be mapped to a different V-pattern. The user can add repetitions to the selected V-pattern group for high speed line shifts or for line binning by using the VREP registers for odd and even lines.

Generally, the same number of repetitions is programmed into both registers. If a different number of repetitions is required on odd and even lines, separate values can be used for each register (see the Generating Line Alternation for V-Sequences and HBLK section). The VSTARTA, VSTARTB, VSTARTC, and VSTARTD registers specify where in the line the V-pattern group starts. The VMASK\_EVEN and VMASK\_ODD registers are used in conjunction with the FREEZE/RESUME registers to enable optional masking of the V-outputs. One or more of the FREEZE1/RESUME1, FREEZE2/RESUME2, FREEZE3/RESUME3, and FREEZE4/RESUME4 registers can be enabled.

The line length (in pixels) is programmable using the HDLEN registers. Each V-sequence can have a different line length to accommodate various image readout techniques. The maximum number of pixels per line is 8192. The last line of the field is programmed separately using the HDLASTLEN register, which is located in the field register section (see Table 64).

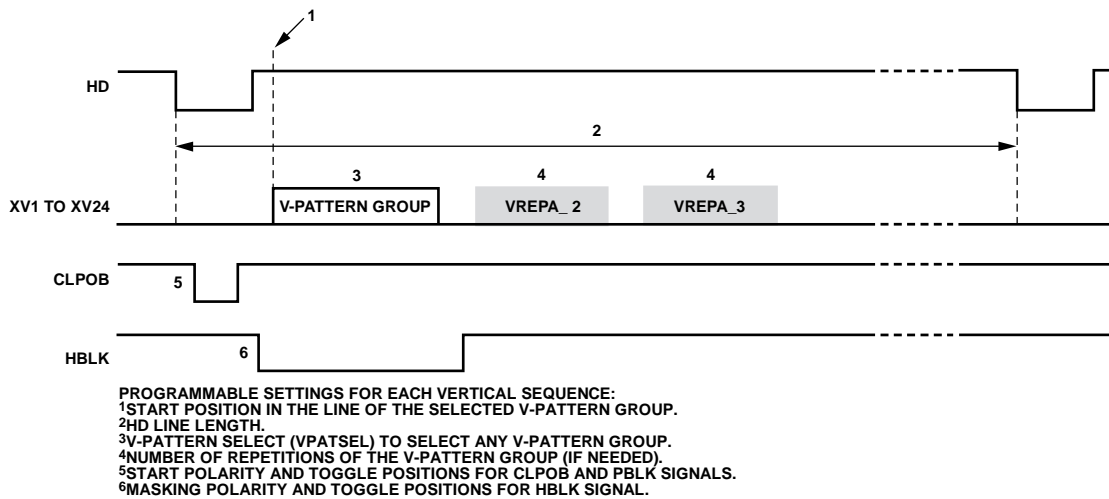

Figure 43. V-Sequence Programmability

06875-0-02

Table 15. Summary of V-Sequence Registers (see Table 11 and Table 12 for the CLPOB, PBLK, and HBLK Register Summary)

Register	Length (Bits)	Description
HOLD	4	Use in conjunction with VMASK_EVEN and VMASK_ODD. 1 = Enable HOLD function instead of FREEZE/RESUME function.
CONCAT_GRP	4	Combines toggle positions of Group A, Group B, Group C, and Group D when enabled. Only Group A settings for start, polarity, length, and repetition are used when this mode is selected. 0 = disable. 1 = enable the addition of all toggle positions from VPATSELA/B/C/D. 2 to 15 = test mode only; do not use.
VREP_MODE	2	Selects line alternation for V-output repetitions. Two separate controls: one for Group A and the other for Group B, Group C, and Group D. 0 = disable alternation. Group A uses VREPA_1, Groups B/C/D use VREP_EVEN for all lines. 1 = two-line. Group A alternates VREPA_1 and VREPA_2. Groups B/C/D alternate VREP_EVEN and VREP_ODD. 2 = three-line. Group A alternates VREPA_1, VREPA_2, and VREPA_3. Groups B/C/D follow a VREP_EVEN, VREP_ODD, VREP_ODD, VREP_EVEN, VREP_ODD, VREP_ODD pattern. 3 = four-line. Group A alternates VREPA_1, VREPA_2, VREPA_3, and VREPA_4. Groups B/C/D follow two-line alternation.
LASTREPLEN_EN	4	Enable a separate pattern length to be used during the last repetition of the V-sequence. One bit for each group (A, B, C, and D); Group A is the LSB. Set bit high to enable. Recommended value is enabled.
HDLENE	14	HD line length for even lines in the V-sequence.
HDLENO	14	HD line length for odd lines in the V-sequence.
VPOL	24	Group A start polarity bits for each XV1 to XV24 signal.
GROUPSEL_0	24	Assigns each XV1 to XV12 signal to Group A, Group B, Group C, or Group D. Two bits for each signal. Bits[1:0] are for XV1. Bits[3:2] are for XV2. Bits[23:22] are for XV12. 0 = assign to Group A. 1 = assign to Group B. 2 = assign to Group C. 3 = assign to Group D.
GROUPSEL_1	24	Assigns each XV13 to XV24 signal to Group A, Group B, Group C, or Group D. Two bits for each signal. Bits[1:0] are for XV13. Bits[3:2] are for XV14. Bits[23:22] are for XV24. 0 = assign to Group A. 1 = assign to Group B. 2 = assign to Group C. 3 = assign to Group D.
VPATSELA	5	Selected V-pattern for Group A.
VPATSELB	5	Selected V-pattern for Group B.
VPATSELC	5	Selected V-pattern for Group C.
VPATSELD	5	Selected V-pattern for Group D.
VSTARTA	13	Start position for the selected V-pattern Group A.
VSTARTB	13	Start position for the selected V-pattern Group B.
VSTARTC	13	Start position for the selected V-pattern Group C.
VSTARTD	13	Start position for the selected V-pattern Group D.
VLENA	13	Length of selected V-pattern Group A.
VLENB	13	Length of selected V-pattern Group B.
VLENC	13	Length of selected V-pattern Group C.
VLEND	13	Length of selected V-pattern Group D.
VREPA_1	13	Number of repetitions for the V-pattern Group A for first lines (even).
VREPA_2	13	Number of repetitions for the V-pattern Group A for second lines (odd).
VREPA_3	13	Number of repetitions for the V-pattern Group A for third lines.
VREPA_4	13	Number of repetitions for the V-pattern Group A for fourth lines.

# AD9920A

Register	Length (Bits)	Description
VREP_B_ODD	13	Number of repetitions for the V-pattern Group B for odd lines.
VREP_C_ODD	13	Number of repetitions for the V-pattern Group C for odd lines.
VREP_D_ODD	13	Number of repetitions for the V-pattern Group D for odd lines.
VREP_B_EVEN	13	Number of repetitions for the V-pattern Group B for even lines.
VREP_C_EVEN	13	Number of repetitions for the V-pattern Group C for even lines.
VREP_D_EVEN	13	Number of repetitions for the V-pattern Group D for even lines.
FREEZE1	13	Pixel location where the V-outputs freeze or hold (see VMASK_EVEN and VMASK_ODD). Also used as VALTSEL0_EVEN, Bits[12:0] register when special VSEQALT_EN mode is enabled.
FREEZE2	13	Pixel location where the V-outputs freeze or hold (see VMASK_EVEN and VMASK_ODD). Also used as VALTSEL1_EVEN, Bits[12:0] register when special VSEQALT_EN mode is enabled.
FREEZE3	13	Pixel location where the V-outputs freeze or hold (see VMASK_EVEN and VMASK_ODD). Also used as VALTSEL0_ODD, Bits[12:0] register when special VSEQALT_EN mode is enabled.
FREEZE4	13	Pixel location where the V-outputs freeze or hold (see VMASK_EVEN and VMASK_ODD). Also used as VALTSEL1_ODD, Bits[12:0] register when special VSEQALT_EN mode is enabled.
RESUME1	13	Pixel location where the V-outputs resume operation (see VMASK_EVEN and VMASK_ODD). Also used as VALTSEL0_EVEN, Bits[17:13] register when special VSEQALT_EN mode is enabled.
RESUME2	13	Pixel location where the V-outputs resume operation (see VMASK_EVEN and VMASK_ODD). Also used as VALTSEL1_EVEN, Bits[17:13] register when special VSEQALT_EN mode is enabled.
RESUME3	13	Pixel location where the V-outputs resume operation (see VMASK_EVEN and VMASK_ODD). Also used as VALTSEL0_ODD, Bits[17:13] register when special VSEQALT_EN mode is enabled.
RESUME4	13	Pixel location where the V-outputs resume operation (see VMASK_EVEN and VMASK_ODD). Also used as VALTSEL1_ODD, Bits[17:13] register when special VSEQALT_EN mode is enabled.
LASTREPLEN_A	13	Separate length for last repetition of vertical pulses for Group A. Must be enabled using LASTREPLEN_EN. Should be programmed to a value equal to the VLENA register.
LASTREPLEN_B	13	Separate length for last repetition of vertical pulses for Group B. Must be enabled using LASTREPLEN_EN. Should be programmed to a value equal to the VLENB register.
LASTREPLEN_C	13	Separate length for last repetition of vertical pulses for Group C. Must be enabled using LASTREPLEN_EN. Should be programmed to a value equal to the VLENC register.
LASTREPLEN_D	13	Separate length for last repetition of vertical pulses for Group D. Must be enabled using LASTREPLEN_EN. Should be programmed to a value equal to the VLEND register.
VSEQALT_EN	1	Special V-sequence alternation mode is enabled when this register is programmed high.
VALTSEL0_EVEN	18	Select lines for special V-sequence alternation mode for even lines. Used to concatenate VPAT Group A, Group B, Group C, and Group D into unique merged patterns. Setting is used to specify one segment, with up to a maximum of 18 segments. (The FREEZE/RESUME registers function as VALTSEL when VSEQALT_EN is enabled.)
VALTSEL1_EVEN	18	Select lines for special V-sequence alternation mode for even lines. Used to concatenate VPAT Group A, Group B, Group C, and Group D into unique merged patterns. Setting is used to specify one segment, with up to a maximum of 18 segments. (The FREEZE/RESUME registers function as VALTSEL when VSEQALT_EN is enabled.)
VALTSEL0_ODD	18	Select lines for special V-sequence alternation mode for odd lines. Used to concatenate VPAT Group A, Group B, Group C, and Group D into unique merged patterns. Setting is used to specify one segment, with up to a maximum of 18 segments. (The FREEZE/RESUME registers function as VALTSEL when VSEQALT_EN is enabled.)
VALTSEL1_ODD	18	Select lines for special V-sequence alternation mode for odd lines. Used to concatenate VPAT Group A, Group B, Group C, and Group D into unique merged patterns. Setting is used to specify one segment, with up to a maximum of 18 segments. (The FREEZE/RESUME registers function as VALTSEL when VSEQALT_EN is enabled.)
SPC_PAT_EN	3	Enable special V-pattern to be inserted into one repetition of a VPATA series. SPC_PAT_EN, Bit 0: set to 1 to enable VPATB to be used as special pattern insertion. SPC_PAT_EN, Bit 1: set to 1 to enable VPATC to be used as special pattern insertion. SPC_PAT_EN, Bit 2: set to 1 to enable VPATD to be used as special pattern insertion.
SEQ_ALT_INC	1	0 = normal operation. 1 = automatically increments the sequence number at the end of the line, unless a sequence change position boundary is reached.
SEQ_ALT_RST	1	0 = normal operation. 1 = automatically resets the sequence number back to the sequence defined for that particular region in the active field register.

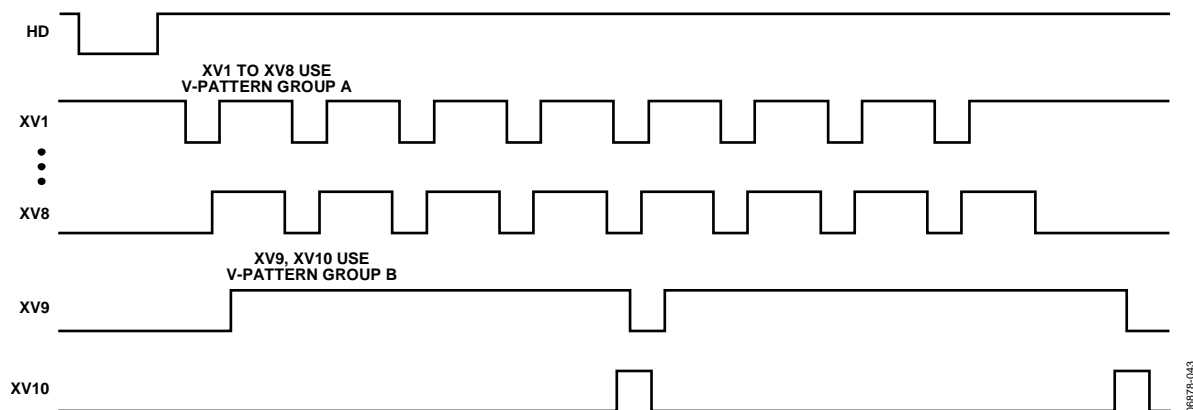

Figure 44. Using Separate Group A and Group B Patterns

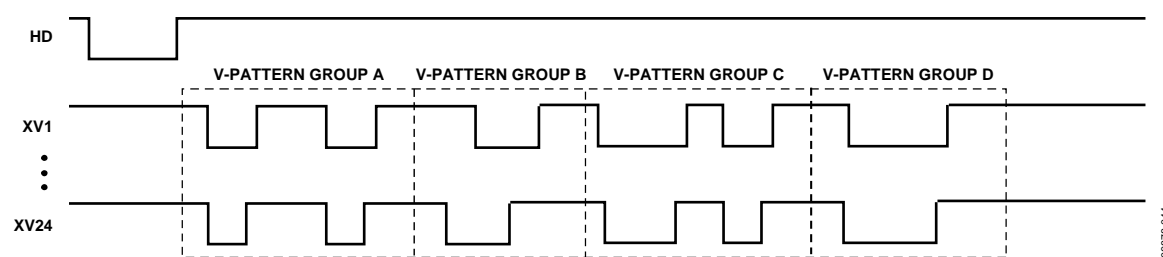

Figure 45. Combining Multiple V-Patterns Using CONCAT\_GRP = 1

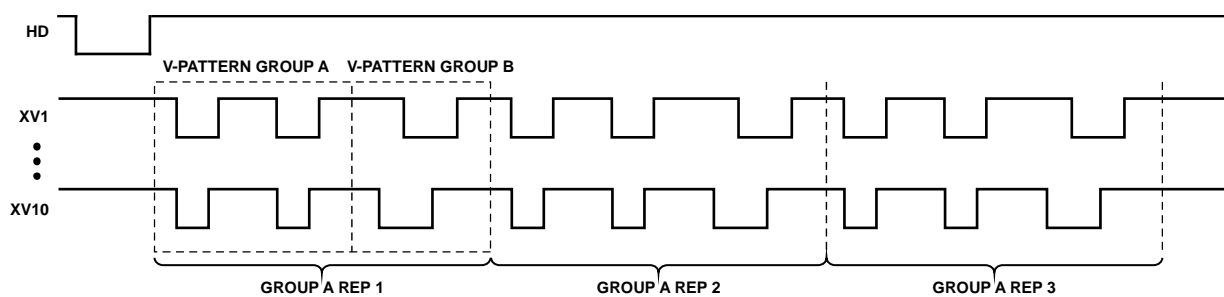

Figure 46. Combining Group A and Group B Patterns with Repetition

### Group A/Group B/Group C/Group D Selection

The AD9920A has the flexibility to use four different V-pattern groups in a vertical sequence. In general, the vertical outputs use the same V-pattern group during a particular sequence. It is possible to assign some of the outputs to a different V-pattern group, which can be useful in certain CCD readout modes.

The GROUPSEL registers are used to select the group (A, B, C, or D) for each V-output. In general, only a single V-pattern group is needed for the vertical outputs; therefore, Group A should be selected for all outputs by default (GROUPSEL\_0, GROUPSEL\_1 = 0x00). In this configuration, all outputs use the V-pattern group specified by the VPATSELA register.

If additional flexibility is needed, some outputs can be set to Group B, Group C, or Group D in the GROUPSEL registers. In this case, those selected outputs use the V-pattern group specified by the VPATSELB, VPATSELC, or VPATSELD registers. Figure 44 shows an example where the V9 and V10 outputs use a separate V-pattern Group B to perform special CCD timing.

Another application of the Group A, Group B, Group C, and Group D registers is to combine up to four different V-pattern groups together for more complex patterns. This is accomplished by setting the CONCAT\_GRP register (Address 0x00, Bits[13:10]) equal to 0x01. This setting combines the toggle positions from the V-pattern groups specified by registers VPATSELA, VPATSELB, VPATSELC, and VPATSELD for a maximum of up to 16 toggle positions. Example timing for the CONCAT\_GRP = 1 feature is shown in Figure 45.

If only two groups are needed (up to eight toggle positions) for the specified timing, the VPATSELB, VPATSELC, and VPATSELD registers can be programmed to the same value. If only three groups are needed, VPATSELC and VPATSELD can be programmed to the same value. Following this approach conserves register memory if the four separate V-patterns are not needed.

Note that when CONCAT\_GRP is enabled, the Group A settings are used only for start position, polarity, length, and repetitions. All toggle positions for Group A, Group B, Group C, and Group D are combined together and applied using the settings in the VSTARTA, VPOL, VLENB, and VREPA registers.

### Special Vertical Sequence Alternation (SVSA) Mode

The AD9920A has additional flexibility for combining four different V-pattern groups in a random sequence that can be programmed for specific CCD requirements. This mode of operation allows custom vertical sequences for CCDs that require more complex vertical timing patterns. For example, using the special vertical sequence alternation mode, it is possible to support random pattern concatenation, with additional support for odd/even line alternation.

Figure 47 illustrates four common and repetitive vertical pattern segments, A through D, that are derived from the complete vertical pattern. Figure 48 illustrates how each group can be concatenated together in an arbitrary order.

To enable the SVSA mode, write the VSEQALT\_EN bit, Address 0x00, Bit 6 in the V-sequence registers, equal to 0x01. This enables the FREEZE/RESUME registers to function as VALTSEL registers.

To create SVSA timing, divide the complete vertical timing pattern into four common and repetitive segments. Identify the related segments as VPATA, VPATB, VPATC, or VPATD. Up to four toggle positions for each segment can be programmed using the V-pattern registers.

Table 16 shows how the segments are specified using a 2-bit representation. Each bit from VALTSEL0 and VALTSEL1 is combined to produce four values, corresponding to Pattern A, Pattern B, Pattern C, and Pattern D.

**Table 16. VALTSEL Bit Settings for Even and Odd Lines**

Parameter	VALTSEL Bit Settings			
VALTSEL0_EVEN	0	0	1	1
VALTSEL1_EVEN	0	1	0	1
VALTSEL0_ODD	0	0	1	1
VALTSEL1_ODD	0	1	0	1
Resulting Pattern for Even Lines	A	B	C	D
Resulting Pattern for Odd Lines	A	B	C	D

When the entire pattern is divided, program VALTSEL0 (even and odd), Bits[17:0] and VALTSEL1 (even and odd), Bits[17:0] so that the segments are concatenated in the desired order. If separate odd and even lines are not required, set the odd and even registers to the same value.

Figure 49 illustrates the process of using six vertical pattern segments that are concatenated into a small, merged pattern.

Program the register VREPA\_1 to specify the number of segments that are concatenated into each merged pattern. The maximum number of segments that can be concatenated to create a merged pattern is 18. Program VLENB, VLENC, and VLEND to be of equal length. Finally, program HBLK to generate the proper H-clock timing using the procedure described in the HBLK Mode 1 Operation section.

It is important to note that because the FREEZE/RESUME registers are used to specify the VALTSEL registers, it is impossible to use both the FREEZE/RESUME functions and the SVSA mode.

**Table 17. VALTSEL Register Locations**

Function of FREEZE/RESUME Registers When VSEQALT_EN = 1	Register Location
VALTSEL0_EVEN, Bits[12:0]	VSEQ register FREEZE1, Bits[12:0]
VALTSEL0_EVEN, Bits[17:13]	VSEQ register RESUME1, Bits[17:13]
VALTSEL1_EVEN, Bits[12:0]	VSEQ register FREEZE2, Bits[12:0]
VALTSEL1_EVEN, Bits[17:13]	VSEQ register RESUME2, Bits[17:13]
VALTSEL0_ODD, Bits[12:0]	VSEQ register FREEZE3, Bits[12:0]
VALTSEL0_ODD, Bits[17:13]	VSEQ register RESUME3, Bits[17:13]
VALTSEL1_ODD, Bits[12:0]	VSEQ register FREEZE4, Bits[12:0]
VALTSEL1_ODD, Bits[17:13]	VSEQ register RESUME4, Bits[17:13]

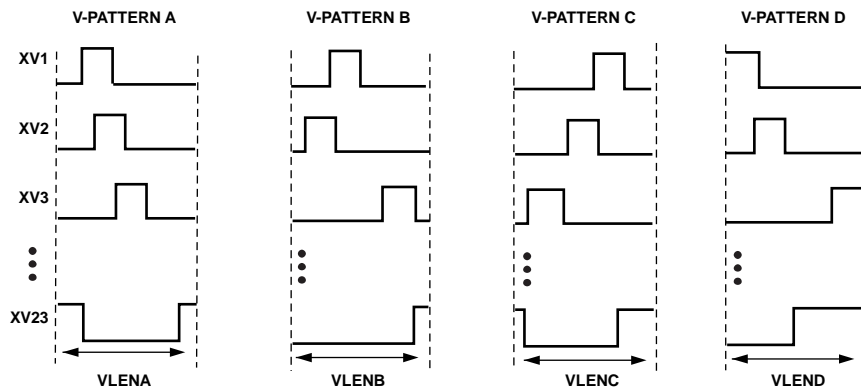

NOTES  
 1. EACH SEGMENT MUST BE THE SAME LENGTH.  
 VLENA = VLENB = VLENC = VLEND.

Figure 47. Vertical Timing Divided into Four Segments: VPATA, VPATB, VPATC, and VPATD

06878-046

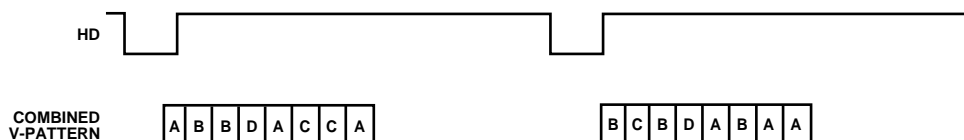

NOTES  
 1. ABLE TO CONCATENATE PATTERNS TOGETHER ARBITRARILY.  
 2. EACH PATTERN CAN HAVE UP TO FOUR TOGGLES PROGRAMMED.  
 3. CAN CONCATENATE UP TO 18 PATTERNS INTO A MERGED PATTERN.  
 4. ODD AND EVEN LINES CAN HAVE A DIFFERENT PATTERN CONCATENATION SPECIFIED BY VALTSEL EVEN AND ODD REGISTERS.

Figure 48. Concatenating Each VPAT Group in an Arbitrary Order

06878-047

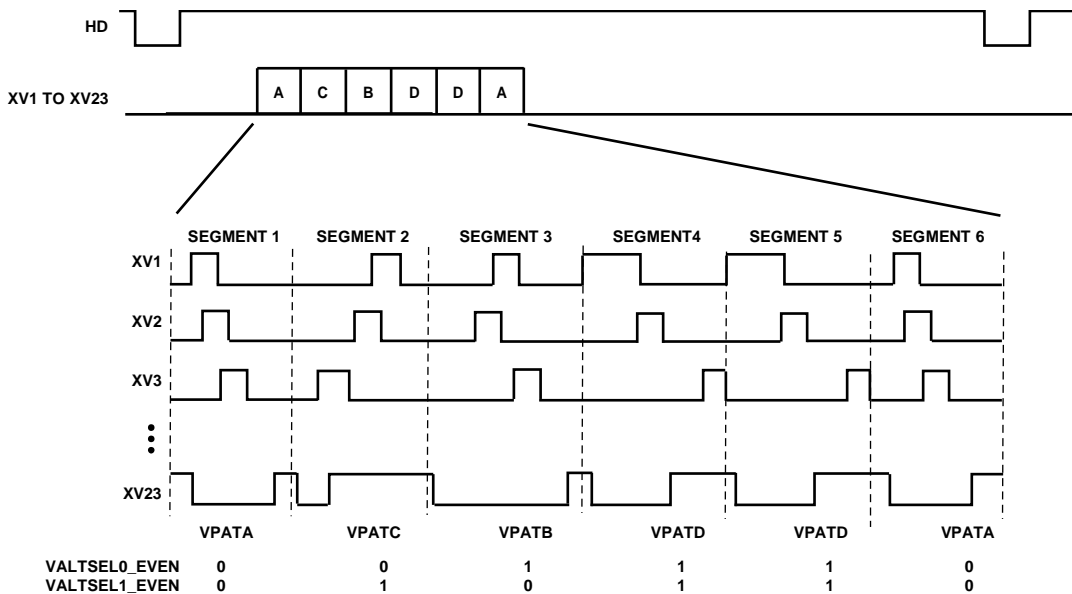

NOTES  
 1. SIX V-PATTERN SEGMENTS CONCATENATED INTO A MERGED PATTERN.  
 2. COMMON AND REPETITIVE VTP SEGMENTS DERIVED FROM THE COMPLETE VTP PATTERN.  
 3. VALTSEL REGISTERS SPECIFY SEGMENT ORDER TO CREATE THE CONCATENATED MERGED PATTERN.

Figure 49. Example of Special V-Sequence Alternation Mode Using VALTSEL Registers to Specify Segment Order

06878-048

## Using the LASTREPLEN\_EN Register

The LASTREPLEN\_EN register (Address 0x00, Bits[19:16] in the V-sequence registers) is used to enable a separate pattern length to be used in the final repetition of several pulse repetitions. If a different last length is not required, it is still recommended that the LASTREPLEN\_EN register bits be set high (enabled) and that the LASTREPLEN\_A, LASTREPLEN\_B, LASTREPLEN\_C, and LASTREPLEN\_D registers be set to a value equal to the VLENA, VLENB, VLENC, and VLEND register values, respectively.

## Generating Line Alternation for V-Sequences and HBLK

During low resolution readout, some CCDs require a different number of vertical clocks on alternate lines. The AD9920A can support this requirement by using the VREP registers. These registers allow a different number of V-pattern group repetitions

to be programmed on odd and even lines. Only the number of repeats can be different in odd and even lines if the V-pattern group remains the same. There are separate controls for the assigned Group A, Group B, Group C, and Group D patterns. All groups can support odd and even line alternation. Group A uses the VREPA\_1 and VREPA\_2 registers; Group B, Group C, and Group D use the corresponding VREP<sub>x</sub>\_ODD and VREP<sub>x</sub>\_EVEN registers. Using the additional VREPA\_3 and VREPA\_4 registers, Group A can also support three-line and four-line alternation.

As described in the Generating HBLK Line Alternation section, the HBLK signal can be alternated for odd and even lines. Figure 50 shows an example of V-pattern group repetition alternation and HBLK Mode 0 alternation used together.

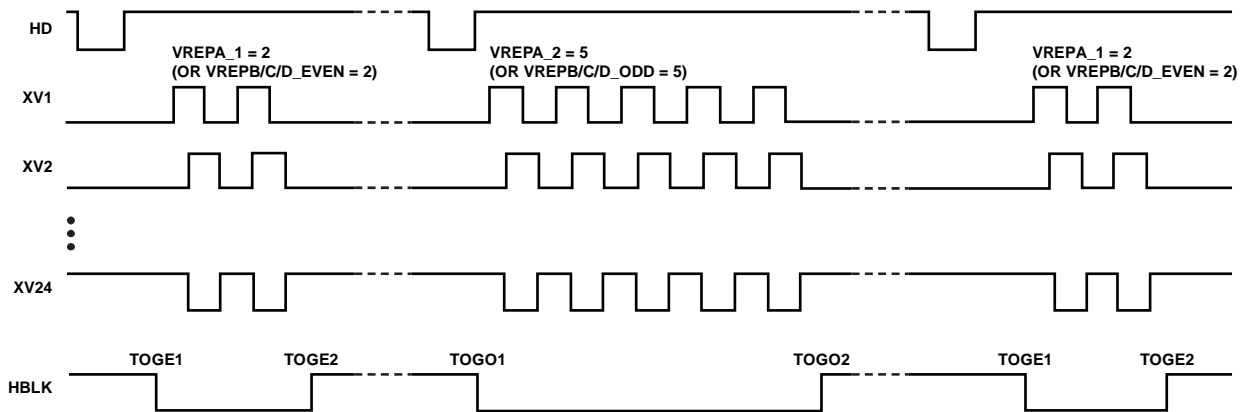

### NOTES

1. THE NUMBER OF REPEATS FOR V-PATTERN GROUPS A/B/C/D CAN BE ALTERNATED ON ODD AND EVEN LINES.
2. GROUP A ALSO SUPPORTS 3- AND 4-LINE ALTERNATION USING THE ADDITIONAL VREPA\_3 AND VREPA\_4 REGISTERS.
3. THE HBLK TOGGLE POSITIONS CAN BE ALTERNATED BETWEEN ODD AND EVEN LINES TO GENERATE DIFFERENT HBLK PATTERNS.

Figure 50. Odd/Even Line Alternation of V-Pattern Group Repetitions and HBLK Toggle Positions

06876-049

**Vertical Masking Using the FREEZE/RESUME Registers**

As shown in Figure 51 and Figure 52, the FREEZE/RESUME registers are used to temporarily mask the V-outputs. The pixel locations to begin the masking (FREEZE) and end the masking (RESUME) create an area in which the vertical toggle positions are ignored. At the pixel location specified in the FREEZE register, the V-outputs are held static at their current dc state, high or low. The V-outputs are held until the pixel location specified by the RESUME register is reached, at which point the signals continue with any remaining toggle positions, if any exist.

Four sets of FREEZE/RESUME registers are provided, allowing the vertical outputs to be interrupted up to four times in the same line.

When masking is enabled, each group (Group A, Group B, Group C, and Group D) uses the same FREEZE/RESUME positions.

Note that the FREEZE/RESUME registers are also used as the VALTSEL0 and VALTSEL1 registers during special vertical alternation mode (see the Special Vertical Sequence Alternation (SVSA) Mode section).

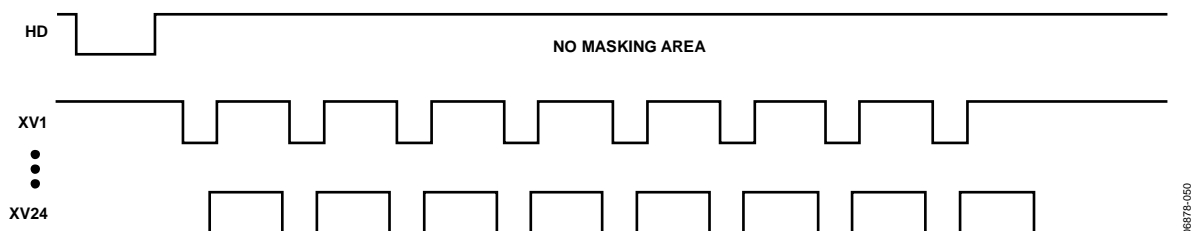
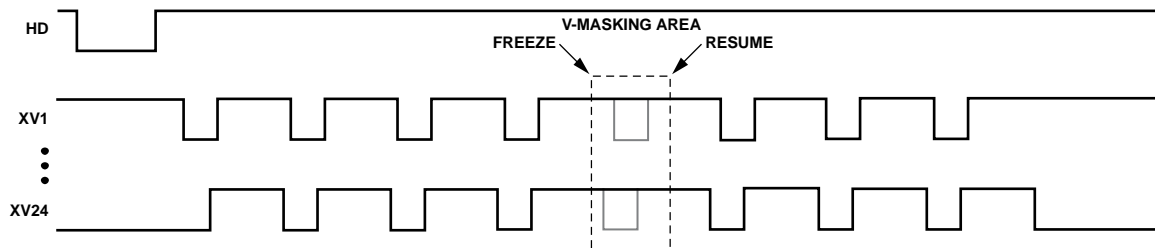

Figure 51. No FREEZE/RESUME

06875-050



- NOTES
1. ALL TOGGLE POSITIONS WITHIN THE FREEZE/RESUME MASKING AREA ARE IGNORED. H-COUNTER CONTINUES TO COUNT DURING MASKING.
  2. FOUR SEPARATE MASKING AREAS ARE AVAILABLE, USING FREEZE1/RESUME1, FREEZE2/RESUME2, FREEZE3/RESUME3, AND FREEZE4/RESUME4 REGISTERS.

Figure 52. Using FREEZE/RESUME

06875-051

## Hold Area Using the FREEZE/RESUME Registers

The FREEZE/RESUME registers can also be used to create a hold area in which the V-outputs are temporarily held and later continued, starting at the point where they were held. As shown in Figure 53, the hold area function is different from the vertical

masking function in that the V-outputs continue from where they stopped rather than continuing from where they would have been. The hold area temporarily stops the pixel counter for the V-outputs, whereas vertical masking allows the counter to continue in the masking area.

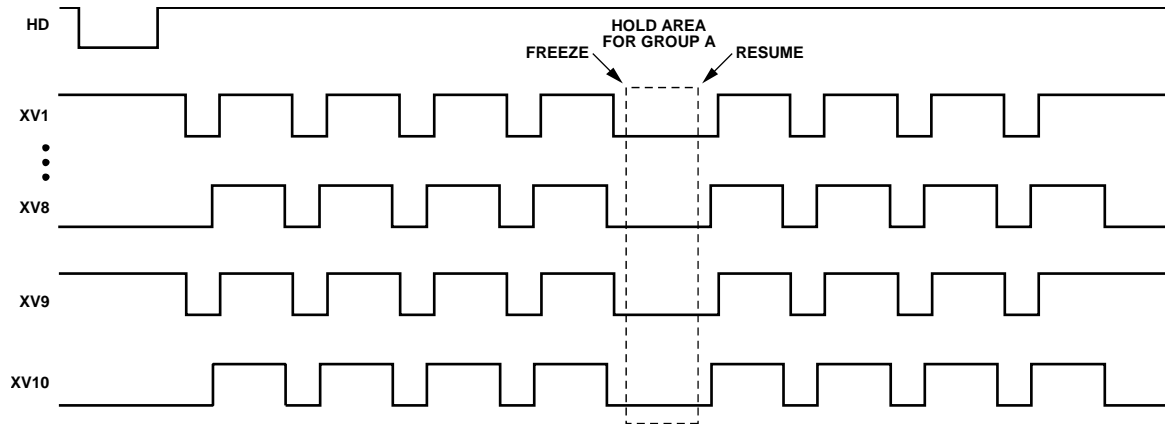

**NOTES**

1. WHEN HOLD = 1 FOR ANY V-SEQUENCE GROUP, THE FREEZE AND RESUME REGISTERS ARE USED TO SPECIFY THE HOLD AREA.
2. IN THIS EXAMPLE, XV1 TO XV10 ARE ASSIGNED TO GROUP A. HOLD BIT FOR GROUP A = 1.
3. H-COUNTER FOR GROUP A (XV1 TO XV10) STOPS DURING HOLD AREA.

Figure 53. Hold Area for Group A

06878-052

**Special Pattern Insertion**

Additional flexibility is available using the SPC\_PAT\_EN register bits, which allow a Group B, Group C, or Group D pattern to be inserted into a series of Group A repetitions. This feature is useful when a different pattern is needed at the start, middle, or end of a sequence.

Figure 54 shows an example of a sweep region using VPATA with multiple repetitions where a single repetition of VPATB

has been added into the middle of the sequence. Figure 55 shows more detail on how to set the registers to achieve the desired timing.

Note that VREP B is used to specify which repetition number has the special pattern inserted instead of VPATA. VPATB always has priority over VPATC or VPATD if more than one SPC\_PAT\_EN bit is enabled (that is, SPC\_PAT\_EN, Bit 0 has priority over SPC\_PAT\_EN, Bit 1 and Bit 2).

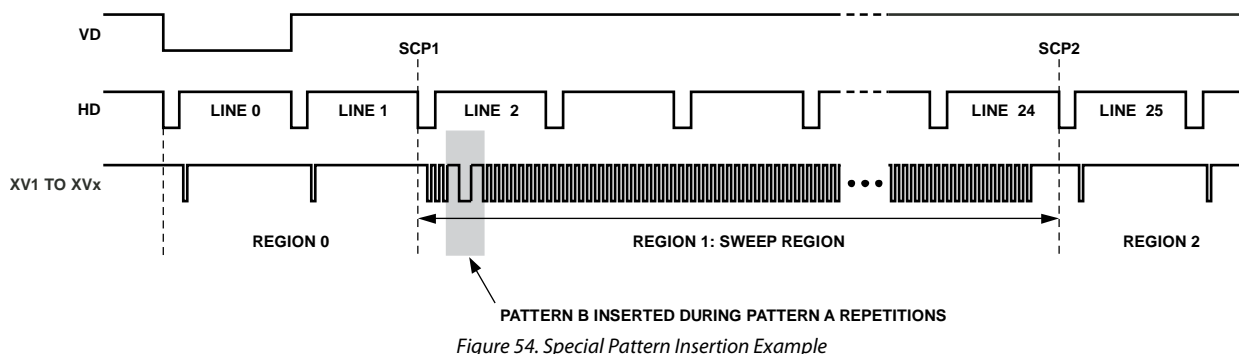

06678-053

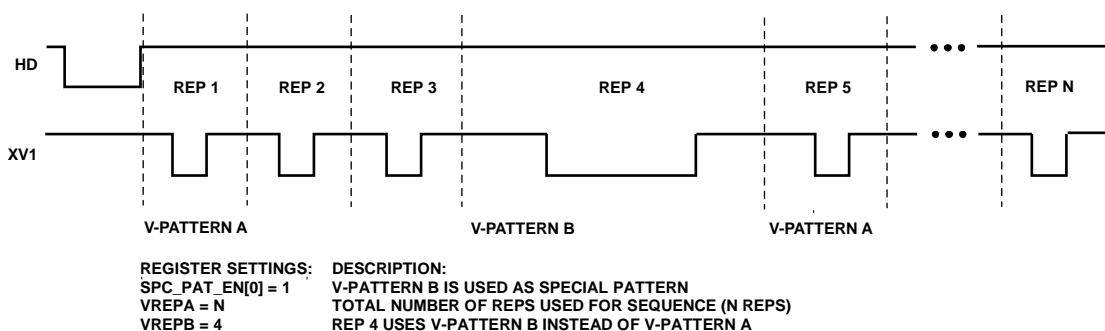

**NOTES**  
1. VSTARTB MUST BE SET EQUAL TO VSTARTA.

Figure 55. Special Pattern Insertion Registers

06678-054

# AD9920A

## Sequence Line Alternation

To support the timing requirements of some advanced CCDs in a memory-efficient manner, the AD9920A can automatically increment the sequence number at the end of a given line through the use of the SEQ\_ALT\_INC register (V-Sequence Register 0x09, Bit 20). It can also reset the sequence number to the sequence defined in the field register through the SEQ\_ALT\_RST register (V-Sequence Register 0x09, Bit 21). Combining these two registers allows the user to create a loop of sequences for a given region. See Figure 56 for an example of how to use these two functions together. The example in Figure 56 uses the register settings listed in Table 18.

With these settings, at Sequence Change Position 0 (SCP0), the AD9920A steps into Sequence 2. Because the Sequence 2 SEQ\_ALT\_INC = 1 and the SEQ\_ALT\_RST = 0, at the end of

that line the sequence number automatically increments to Sequence 3. In the same way, at the end of that line, the sequence number automatically increments to Sequence 4.

Because SEQ\_ALT\_INC = 0 and SEQ\_ALT\_RST = 1 for Sequence 4, the AD9920A automatically resets the sequence number to the sequence defined for that region in the field register, which in this case is Sequence 2. The AD9920A continues to loop in this fashion between Sequence 2, Sequence 3, and Sequence 4 until it reaches the next sequence change position.

It is important to note that the sequence number can increment only at the end of a line and cannot be used to create more complex patterns within one line. This is distinctly different from the special vertical sequence alternation mode, which allows the user to concatenate multiple sequences within one line (see the Special Vertical Sequence Alternation (SVSA) Mode section).

**Table 18. Register Settings for the Example in Figure 56**

Field Registers	Sequence 2 Registers	Sequence 3 Registers	Sequence 4 Registers	Sequence 6 Registers
SCP0 = 0, SEQ0 = 2	SEQ_ALT_INC = 1	SEQ_ALT_INC = 1	SEQ_ALT_INC = 0	SEQ_ALT_INC = 0
SCP1 = 6, SEQ1 = 6	SEQ_ALT_RST = 0	SEQ_ALT_RST = 0	SEQ_ALT_RST = 1	SEQ_ALT_RST = 0

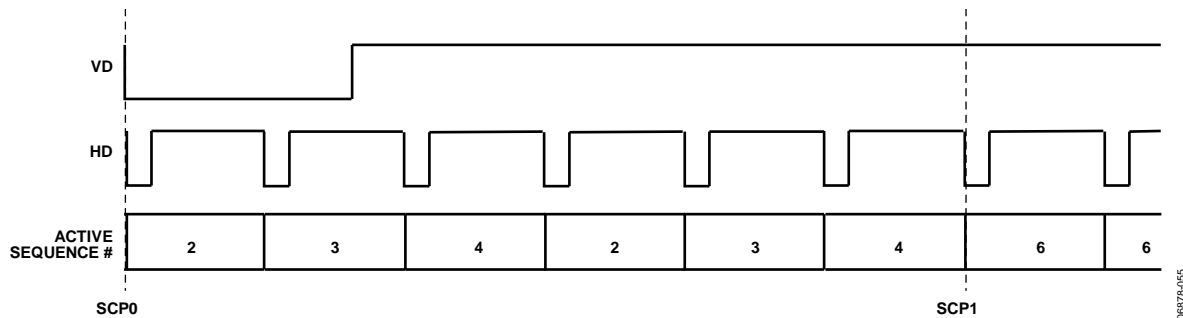

Figure 56. Example Output Using SEQ\_ALT\_INC and SEQ\_ALT\_RST Functions

### Complete Field: Combining V-Sequences

After the V-sequences are created, they are combined to create different readout fields. A field consists of up to nine regions; within each region, a different V-sequence can be selected. Figure 57 shows how the sequence change positions (SCPs) designate the line boundary for each region and how the SEQ registers then select which V-sequence is used in each region. Registers to control the VSG outputs are also included in the field registers. Table 19 summarizes the registers used to create the various fields.

The SEQ registers, one for each region, select which of the V-sequences are active in each region. The MULT\_SWEEP registers, one for each region, are used to enable sweep mode and/or multiplier mode in any region. The SCP registers create the line boundaries for each region. The VDLEN register specifies the total number of lines in the field. The HDLEN registers specify the total number of pixels per line.

The HDLASTLEN register specifies the number of pixels in the last line of the field.

The SGMASK register is used to enable or disable each individual VSG output. There are two bits for each VSG output to enable separate masking in SGACTLINE1 and SGACTLINE2.

Setting a masking bit high masks the output; setting it low enables the output. The VSGPATSEL register assigns one of the eight SG patterns to each VSG output. The individual SG patterns are created separately using the SG pattern registers. The SGACTLINE1 register specifies which line in the field contains the VSG outputs. The optional SGACTLINE2 register allows VSG pulses to be output on a different line. Separate masking is not available for SGACTLINE1 and SGACTLINE2, unless separate sequences are assigned to SGACTLINE1 and SGACTLINE2. Note that to ensure proper SUBCK operation when using both SGACTLINE1 and SGACTLINE2, SGACTLINE2 must be programmed to occur before SGACTLINE1.

**Table 19. Field Registers (CLPOB, PBLK Masking Shown in Table 11)**

Register	Length (Bits)	Range	Description
SEQ	5	0 to 31 V-sequence number	Selected V-sequence for each region in the field.
MULT_SWEEP	2	0 to 3	Enable multiplier mode and/or sweep mode for each region. 0 = multiplier off, sweep off. 1 = multiplier off, sweep on. 2 = multiplier on, sweep off. 3 = multiplier on, sweep on.
SCP	13	0 to 8191 line number	Sequence change position for each region.
VDLEN	13	0 to 8191 lines	Total number of lines in each field.
HDLASTLEN	13	0 to 8191 pixels	Length in pixels of the last HD line in each field.
VSGPATSEL	24	High/low	VSGPATSEL selects which two V-pattern toggle positions are used by each V-output. Each bit represents one V-output: Bit 0 = XV1 output, Bit 23 = XV24 output. 0 = use TOG1 and TOG2. 1 = use TOG3 and TOG4.
SGMASK	24	High/low, each VSG	Set high to mask each individual VSG output. Bit 0: XV1 mask. Bit 23: XV24 mask.
SGACTLINE1	13	0 to 8191 line number	Selects the line in the field where the VSG signals are active.
SGACTLINE2	13	0 to 8191 line number	Selects a second line in the field to repeat the VSG signals. If this register is not used, set it equal to SGACTLINE1 or to the maximum value.

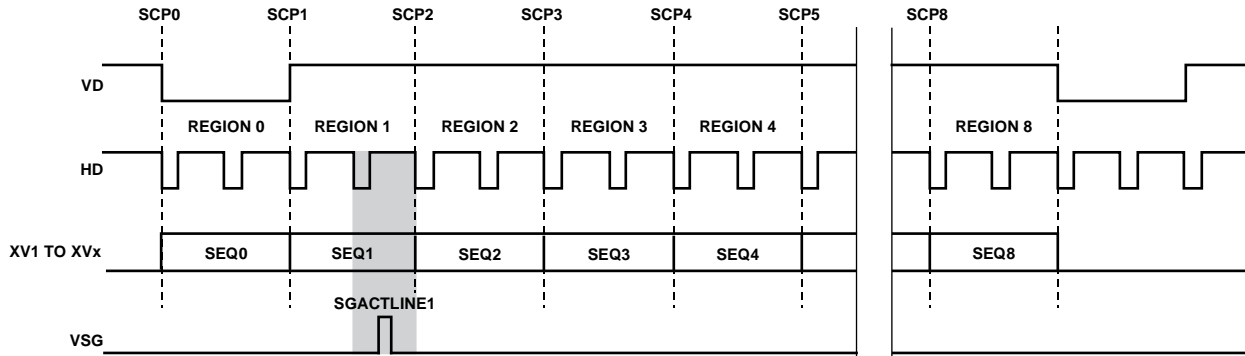

**FIELD SETTINGS:**  
 1. SEQUENCE CHANGE POSITIONS (SCP0 TO SCP8) DEFINE EACH OF THE NINE AVAILABLE REGIONS IN THE FIELD.  
 2. SEQ0 TO SEQ8 SELECT THE DESIRED V-SEQUENCE FOR EACH REGION.  
 3. SGACTION1 REGISTER SELECTS WHICH HD LINE IN THE FIELD CONTAINS THE SENSOR GATE PULSE(S).

Figure 57. Complete Field Divided into Regions

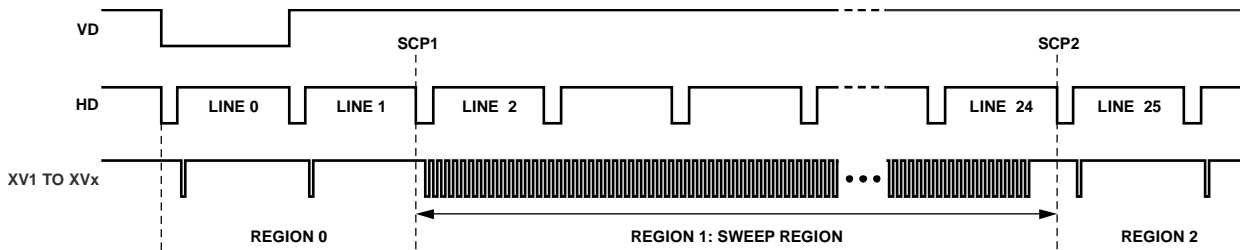

Figure 58. Example of Sweep Region for High Speed Vertical Shift

## Sweep Mode Operation

The AD9920A contains an additional mode of vertical timing operation called sweep mode. This mode is used to generate a large number of repetitive pulses that span across multiple HD lines. An example of where this mode is needed is at the start of the CCD readout operation. At the end of the image exposure before the image is transferred by the sensor gate pulses, the vertical interline CCD registers should be free of all charge. This can be accomplished by quickly shifting out any charge using a long series of pulses from the vertical outputs. Depending on the vertical resolution of the CCD, up to 3000 clock cycles might be needed to shift the charge out of each vertical CCD line. This operation spans across multiple HD line lengths. Normally, the AD9920A vertical timing must be contained within one HD line length, but when sweep mode is enabled, the HD boundaries are ignored until the region is finished. To enable sweep mode within any region, program the appropriate SWEEP register to high.

Figure 58 shows an example of the sweep mode operation. The number of vertical pulses needed depends on the vertical resolution of the CCD. The toggle positions for the XV1 to XV24 signals are generated using the V-pattern registers (see Table 14). A single pulse is created using the polarity and toggle position registers. The number of repetitions is then programmed to match the number of vertical shifts required by the CCD. Repetitions are programmed into the V-sequence registers using the VREP registers (see Table 15). This produces a pulse train of the appropriate length. Normally, the pulse train is truncated at the end of the HD line length, but when sweep mode is enabled for this region, the HD boundaries are ignored.

In Figure 58, the sweep region occupies 23 HD lines. After the sweep mode region is complete, normal sequence operation resumes in the next region. When using sweep mode, be sure to set the region boundaries (using the sequence change positions) to the appropriate lines to prevent the sweep operation from overlapping with the next V-sequence.

**Multiplier Mode**

To generate very wide vertical timing pulses, a vertical region can be configured into a multiplier region. This mode uses the V-pattern registers in a slightly different manner. Multiplier mode can be used to support unusual CCD timing requirements, such as vertical pulses that are wider than the 13-bit V-pattern toggle position counter. In general, the 13-bit toggle position counter can be used with the sweep mode feature to support very wide pulses; however, multiplier mode can be used to generate even wider pulses.

The start polarity and toggle positions are still used in the same manner as in the standard V-pattern group programming, but VLEN is used differently. Instead of using the pixel counter (HD counter) to specify the toggle position locations (VTOG1, VTOG2, VTOG3, and VTOG4) of the V-pattern group, the VLEN is multiplied by the VTOG position to allow very long pulses to be generated.

To calculate the exact toggle position, which is counted in pixels after the start position, use the following equation:

$$\text{Multiplier Mode Toggle Position} = \text{VTOG} \times \text{VLEN}$$

Because the VTOG register is multiplied by VLEN, the resolution of the toggle position placement is reduced. If VLEN = 4, the toggle position precision is reduced to four-pixel increments instead of to single-pixel increments. Table 20 summarizes how the V-pattern group registers are used in multiplier mode operation. In multiplier mode, the VREP registers must always be programmed to the same value as the highest toggle position.

Figure 59 illustrates this operation. The first toggle position is 2, and the second toggle position is 9. In nonmultiplier mode, this causes the V-sequence to toggle at Pixel 2 and then at Pixel 9 within a single HD line. However, in multiplier mode, toggle positions are multiplied by the value of VLEN (in this case, 4); therefore, the first toggle occurs at Pixel 8, and the second toggle occurs at Pixel 36. Sweep mode is also enabled to allow the toggle positions to cross the HD line boundaries.

**Table 20. Multiplier Mode Register Parameters**

Register	Length (Bits)	Range	Description
MULT_SWEEPx	1	High/low	High enables multiplier mode.
VPOL	1	High/low	Starting polarity of XV1 to XV24 signals in each V-pattern group.
VTOG	13	0 to 8191 pixel location	Toggle positions for XV1 to XV24 signals in each V-pattern group.
VLEN	13	0 to 8191 pixels	Used as multiplier factor for toggle position counter.
VREP	13	0 to 8191 pixel location	With VREP_MODE = 0, VREP_EVEN must be set to the same value as the highest VTOG value. VREP_ODD and VREPA can be set to 0.

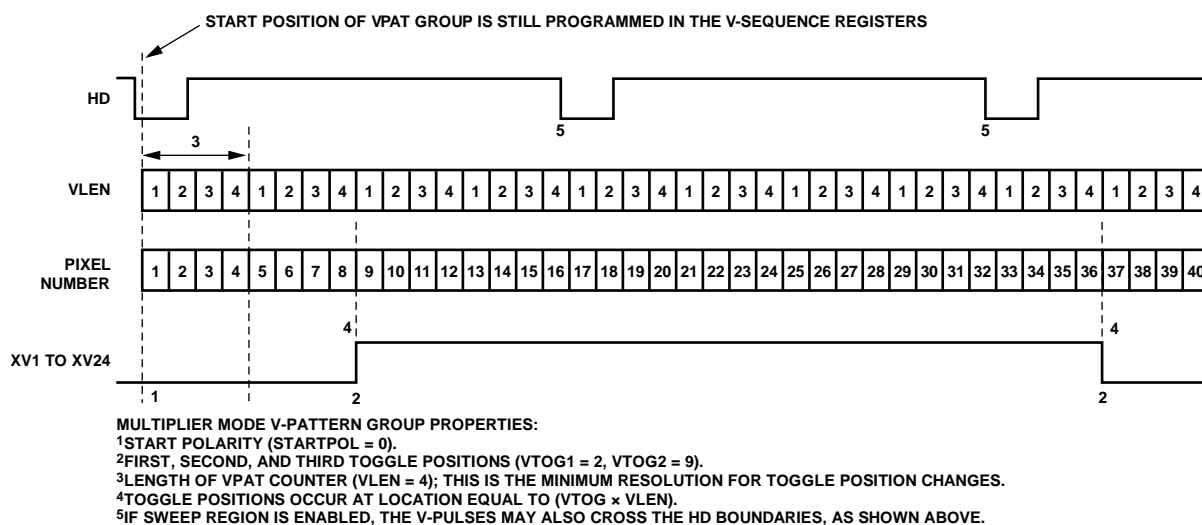

Figure 59. Example of Multiplier Region for Wide Vertical Pulse Timing

0887B-058

## Vertical Sensor Gate (Shift Gate) Patterns

In an interline CCD, the vertical sensor gate (VSG) pulses are used to transfer the pixel charges from the light-sensitive image area into light-shielded vertical registers. From the light-shielded vertical registers, the image is clocked out line-by-line using the vertical transfer pulses (XV signals) in conjunction with the high speed horizontal clocks. The AD9920A has 24 vertical signals, and each signal can be assigned as a VSG pulse instead of as an XV pulse.

Table 21 summarizes the VSG control registers, which are mainly located in the field register space (see Table 19). The VSGSELECT register (Address 0x1C in the fixed address space) determines which vertical outputs are assigned as VSG pulses. When a signal is selected to be a VSG pulse, only the starting polarity and two of the V-pattern toggle positions are used. The VSGPATSEL register in the V-sequence registers is used to assign either TOG1 and TOG2 or TOG3 and TOG4 to the VSG signal.

Note that only two of the four V-pattern toggle positions are available when a vertical signal is selected to be a VSG pulse.

The SGACTION1 and SGACTION2 registers are used to select which line in the field is the VSG line. The VSG active line location is used to reference when the substrate clocking (SUBCK) signal begins to operate in each field. For more information, see the Substrate Clock Operation (SUBCK) section.

Also located in the field registers, the SGMASK register selects which individual VSG pulses are active in a given field. Therefore, all SG patterns to be preprogrammed into the V-pattern registers and the appropriate pulses for the different fields can be enabled separately.

The AD9920A is an integrated AFETG and V-driver, so the connections between the AFETG and V-driver are fixed, as shown in Figure 65 and Figure 66. The VSGSELECT register must be programmed to 0xFF8000.

**Table 21. VSG Control Registers (also see Field Registers in Table 19)**

Register	Length (Bits)	Range	Description
VSGSELECT (Located in Fixed Address Space, 0x1C)	24	High/low	Selection of VSG signals from XV signals. Set to 1 to make signal a VSG. The recommended setting for this register is 0xFF8000. Bit 0: XV1 selection (0 = XV pulse; 1 = VSG pulse). Bit 1: XV2 selection. Bit 23: XV24 selection.
VSGPATSEL	24	High/low	When VSG signal is selected using the VSGSELECT register, VSGPATSEL selects which V-pattern toggle positions are used. When this register is set to 0, Toggle 1 and Toggle 2 are used. When this register is set to 1, Toggle 3 and Toggle 4 are used. Bit 0: XV1 selection (0 = use TOG1, TOG2; 1 = use TOG3, TOG4). Bit 1: XV2 selection. Bit 23: XV24 selection.
SGMASK	24	High/low, each VSG	Set high to mask each individual VSG output. Bit 0: XV1 mask. Bit 23: XV24 mask.
SGACTION1	13	0 to 8191 line number	Selects the line in the field where the VSG signals are active.
SGACTION2	13	0 to 8191 line number	Selects a second line in the field to repeat the VSG signals. If this register is not used, set it equal in value to SGACTION1 or to the maximum value.

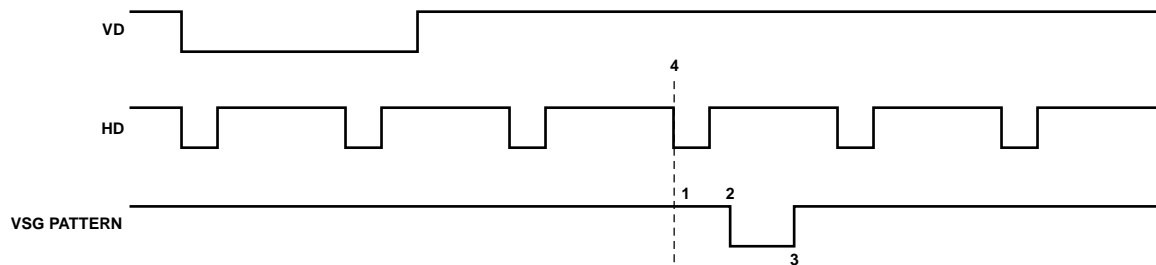

PROGRAMMABLE SETTINGS FOR EACH PATTERN:  
<sup>1</sup>START POLARITY OF PULSE (FROM VPOL IN SEQUENCE REGISTERS).  
<sup>2</sup>FIRST TOGGLE POSITION (FROM V-PATTERN REGISTERS).  
<sup>3</sup>SECOND TOGGLE POSITION (FROM V-PATTERN REGISTERS).  
<sup>4</sup>ACTIVE LINE FOR VSG PULSES WITHIN THE FIELD (FROM FIELD REGISTERS).

Figure 60. Vertical Sensor Gate Pulse Placement

068716-058

### Mode Registers

The mode registers are used to select the field timing of the AD9920A. Typically, all of the field, V-sequence, and V-pattern information is programmed into the AD9920A at startup. During operation, the mode registers allow the user to select any combination of field timing to meet the requirements of the system. The advantage of using the mode registers in conjunction with preprogrammed timing is that it greatly reduces the system programming requirements during camera operation. Only a few register writes are required when the camera operating mode is changed; the vertical timing information does not need to be changed with each camera mode change.

A basic still camera application can require six fields of vertical timing—one for draft mode operation, one for autofocusing, and four for still image readout. All of the register timing information for the six fields is loaded at startup. Then, during camera operation, the mode registers select which field timing is active, depending on how the camera is being used.

Table 22 shows how the mode registers are used. The mode register (Address 0x2A) specifies how many total fields are used. Any value from 1 to 7 can be selected using these three bits.

The other two registers (Address 0x2B and Address 0x2C) are used to select which of the programmed fields are used and in which order. Up to seven fields can be used in a single write to the mode register. The AD9920A starts with the field timing specified by FIELD1, and on the next VD switches to the timing specified by FIELD2, and so on. After completing the total number of fields specified by the mode register, the AD9920A repeats by starting at the first field. This continues until a new write to the mode register occurs. Figure 61 shows example mode register settings for different field configurations.

Note that only a write to Address 0x2C properly resets the field counter. Therefore, when changing the values in any of the mode registers, it is recommended that all three registers be updated together in the same field (VD period).

#### Caution

The mode registers are SCK updated by default. If they are configured as VD-updated registers by writing Address 0xB4 = 0x03FF and Address 0xB5 = 0xFC00, the new mode information is updated on the second VD falling edge after the write occurs, rather than on the first VD falling edge. See Figure 63 for an example.

**Table 22. Mode Registers**

Address	Name	Length (Bits)	Description
0x2A	MODE	3	Total number of fields to cycle through. Set from 1 to 7.
0x2B	FIELD1	5	Selected field (from FIELD registers in configurable memory) for the first field to cycle through.
	FIELD2	5	Selected field (from FIELD registers in configurable memory) for the second field to cycle through.
	FIELD3	5	Selected field (from FIELD registers in configurable memory) for the third field to cycle through.
	FIELD4	5	Selected field (from FIELD registers in configurable memory) for the fourth field to cycle through.
	FIELD5	5	Selected field (from FIELD registers in configurable memory) for the fifth field to cycle through.
0x2C	FIELD6	5	Selected field (from FIELD registers in configurable memory) for the sixth field to cycle through.
	FIELD7	5	Selected field (from FIELD registers in configurable memory) for the seventh field to cycle through.

**EXAMPLE 1:**  
 TOTAL FIELDS = 3, FIRST FIELD = FIELD1, SECOND FIELD = FIELD2, THIRD FIELD = FIELD3  
 MODE SETTINGS:  
 0x2A = 0x03  
 0x2B = 0x820  
 0x2C = 0x00

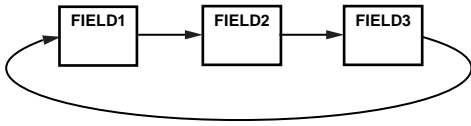

**EXAMPLE 2:**  
 TOTAL FIELDS = 1, FIRST FIELD = FIELD3  
 MODE SETTINGS:  
 0x2A = 0x01  
 0x2B = 0x03  
 0x2C = 0x00

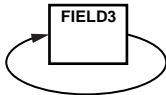

**EXAMPLE 3:**  
 TOTAL FIELDS = 4, FIRST FIELD = FIELD5, SECOND FIELD = FIELD1, THIRD FIELD = FIELD4, FOURTH FIELD = FIELD2  
 MODE SETTINGS:  
 0x2A = 0x04  
 0x2B = 0x11025  
 0x2C = 0x00

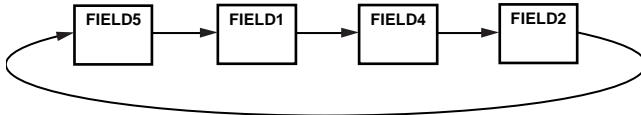
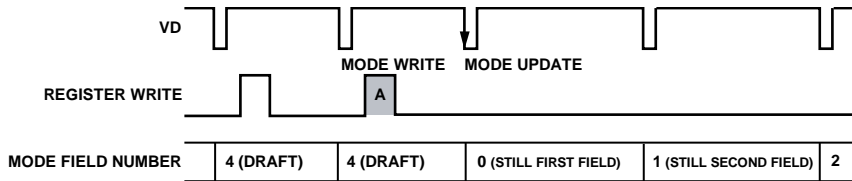

Figure 61. Using the Mode Registers to Select Field Timing

068778-062



**EXAMPLE MODE REGISTER CHANGE:**  
 REGISTER WRITE A—WRITE TO MODE REGISTERS 0x2A, 0x2B, 0x2C TO SPECIFY CHANGE FROM DRAFT MODE (FIELD4) TO STILL MODE (FIELD1/2/3).  
 ALSO WRITE TO VGA GAIN OR ANY NEW REGISTER VALUES NEEDED FOR STILL FRAME OPERATION, SUCH AS NEW FIELD INFORMATION.

Figure 62. Update of Mode Register, SCK Updated (Default Setting)

068778-060

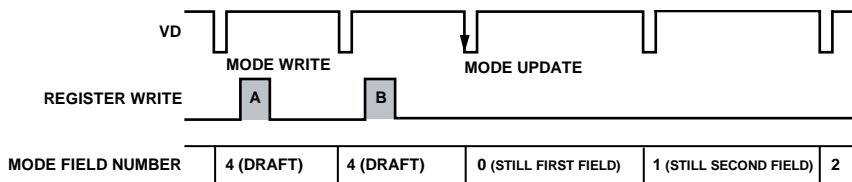

**EXAMPLE MODE REGISTER CHANGE:**  
 REGISTER WRITE A—WRITE TO MODE REGISTERS 0x2A, 0x2B, 0x2C TO SPECIFY CHANGE FROM DRAFT MODE (FIELD4) TO STILL MODE (FIELD1/2/3).  
 REGISTER WRITE B—WRITE TO VGA GAIN OR ANY NEW REGISTER VALUES NEEDED FOR STILL FRAME OPERATION, SUCH AS NEW FIELD INFORMATION.

**NOTES**  
 1. NEW MODE INFORMATION IS UPDATED AT SECOND VD FALLING EDGE AFTER SERIAL WRITE A.

Figure 63. Update of Mode Register, VD Updated

068778-061

## VERTICAL TIMING EXAMPLE

To better understand how the AD9920A vertical timing generation is used, consider the example CCD timing chart in Figure 64. This example illustrates a CCD using a general three-field readout technique. As shown in Figure 64, each readout field must be divided into separate regions to perform each step of the readout. The sequence change positions (SCPs) determine the line boundaries for each region, and the SEQ registers assign a particular V-sequence to each region. The V-sequences contain the specific timing information required in each region: V1 to V6 pulses (using V-pattern groups), HBLK/CLPOB timing, and VSG patterns for the SG active lines.

This timing example requires four regions for each of the three fields, labeled Region 0, Region 1, Region 2, and Region 3. Because the AD9920A allows many individual fields to be programmed, FIELD1, FIELD2, and FIELD3 can be used to meet the requirements of this timing example. The four regions for each field are very similar in this example, but the individual registers for each field allow flexibility to accommodate other timing charts.

Region 0 is a high speed, vertical shift region. Sweep mode can be used to generate this timing operation with the desired number of high speed vertical pulses needed to clear any charge from the CCD vertical registers.

Region 1 consists of only two lines and uses standard single-line vertical shift timing. The timing of this region area is the same as the timing in Region 3.

Region 2 is the sensor gate line in which the VSG pulses transfer the image into the vertical CCD registers. This region may require the use of the second V-pattern group for the SG active line.

Region 3 also uses the standard single-line vertical shift timing, the same timing as Region 1. Four regions are required in each of the three fields.

The timing for Region 1 and Region 3 is essentially the same, reducing the complexity of the register programming. Other registers must be used during the actual readout operation. These include the mode registers, shutter control registers (PRIMARY\_ACTION, SUBCK, and GPO for MSHUT and VSUB control), and AFE gain registers.

### ***Important Note Regarding Signal Polarities***

When programming the AD9920A to generate the V1 to V24 and SUBCK signals, the external V-driver circuit usually inverts these signals. Carefully check the timing signals that are required at the input and output of the V-driver circuit being used, and adjust the polarities of the AD9920A outputs accordingly.

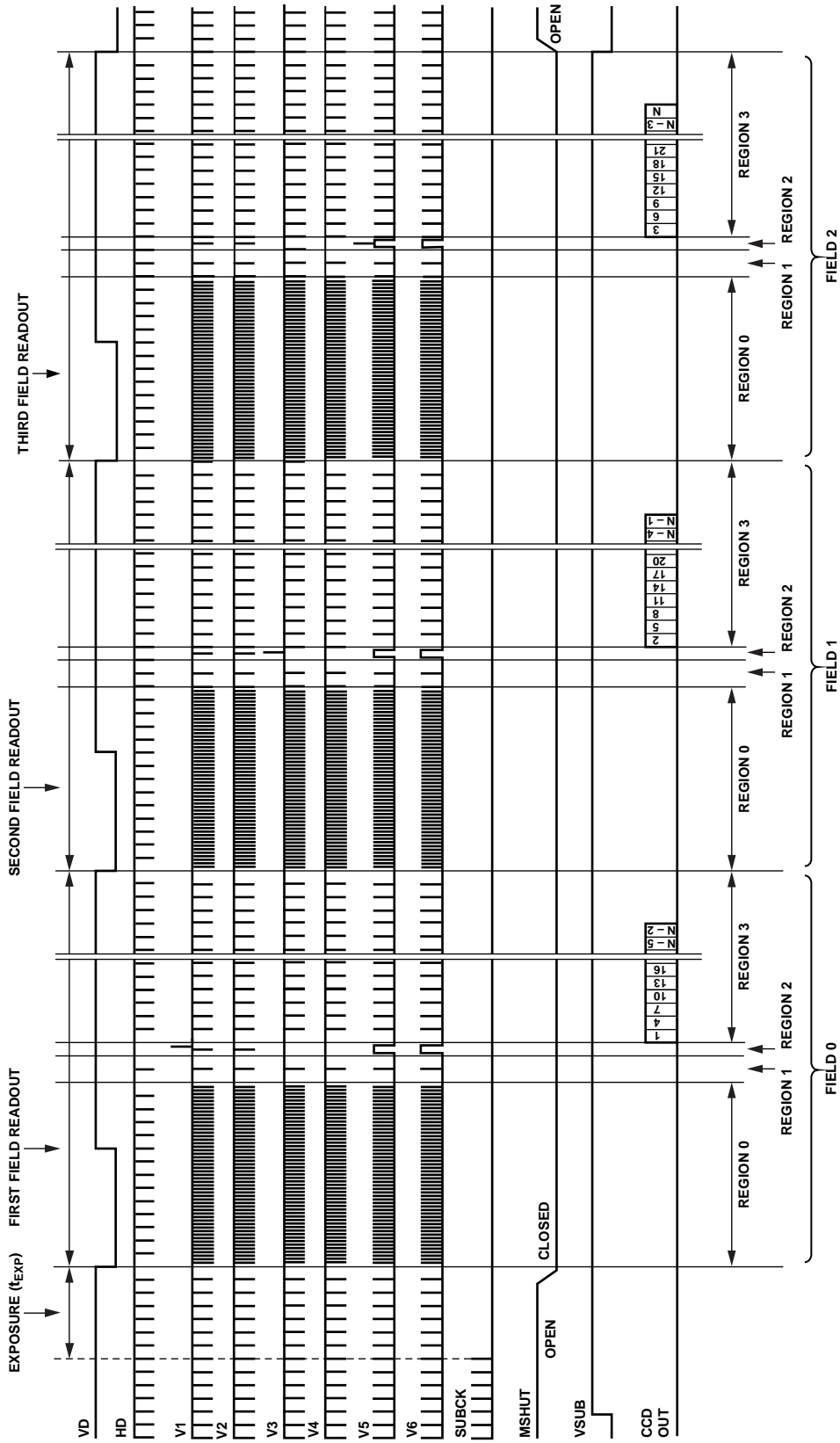

Figure 64. CCD Timing Example—Dividing Each Field into Regions

06878-083

INTERNAL VERTICAL DRIVER CONNECTIONS (18-CHANNEL MODE)

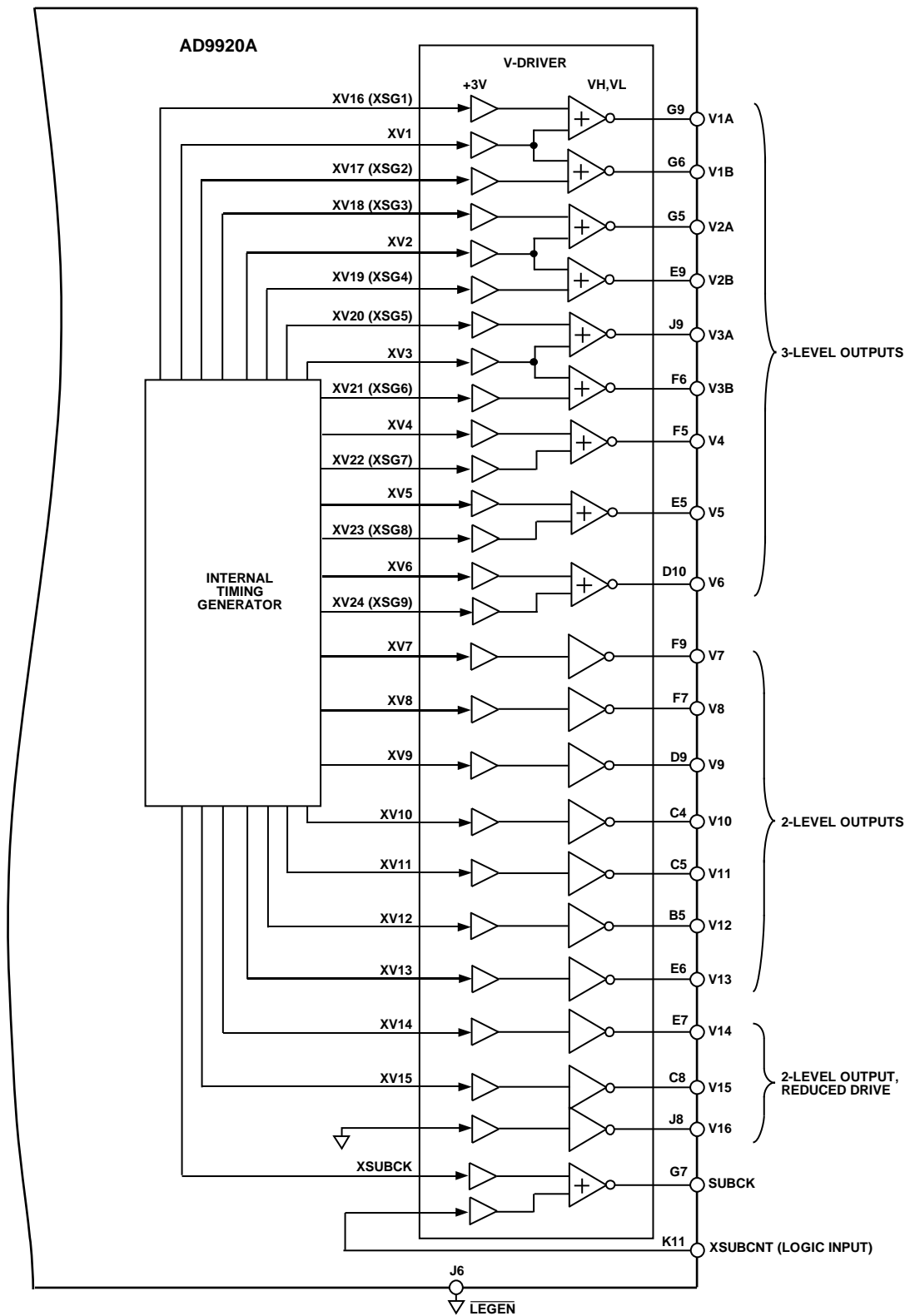

Figure 65. Internal AFETG to V-Driver Connections, Legacy Mode (18-Channel Mode)

06978-064

# AD9920A

## INTERNAL VERTICAL DRIVER CONNECTIONS (19-CHANNEL MODE)

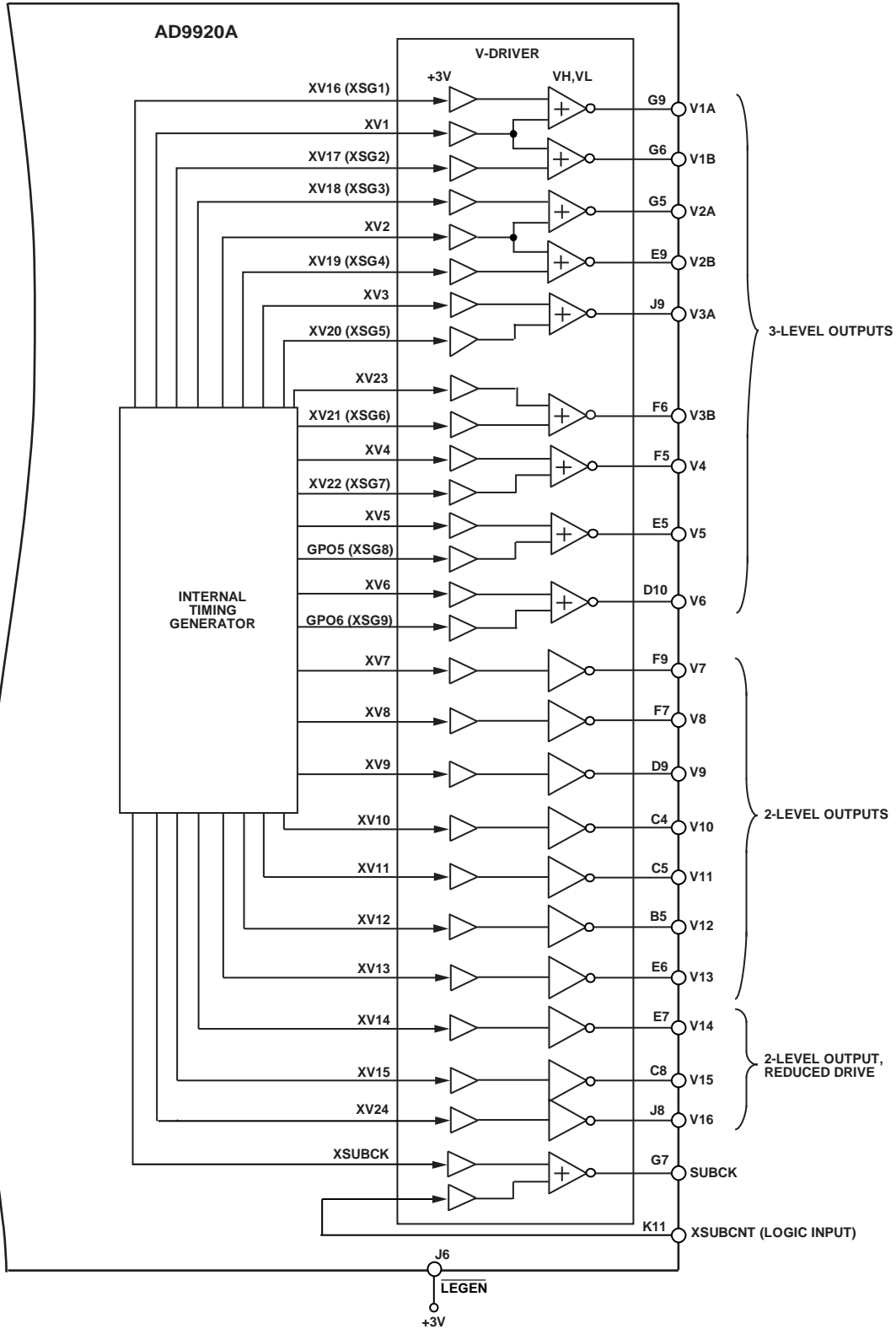

Figure 66. Internal AFETG to V-Driver Connections (19-Channel Mode)

06978-005

## OUTPUT POLARITY OF VERTICAL TRANSFER CLOCKS AND SUBSTRATE CLOCK

Table 23. V1A Output Polarity

LEGEN	Vertical Driver Input		V1A Output
	XV1	XV16 (XSG1)	
X	L	L	VH
X	L	H	VM
X	H	L	VL
X	H	H	VL

Table 24. V1B Output Polarity

LEGEN	Vertical Driver Input		V1B Output
	XV1	XV17 (XSG2)	
X	L	L	VH
X	L	H	VM
X	H	L	VL
X	H	H	VL

Table 25. V2A Output Polarity

LEGEN	Vertical Driver Input		V2A Output
	XV2	XV18 (XSG3)	
X	L	L	VH
X	L	H	VM
X	H	L	VL
X	H	H	VL

Table 26. V2B Output Polarity

LEGEN	Vertical Driver Input		V2B Output
	XV2	XV19 (XSG4)	
X	L	L	VH
X	L	H	VM
X	H	L	VL
X	H	H	VL

Table 27. V3A Output Polarity

LEGEN	Vertical Driver Input		V3A Output
	XV3	XV20 (XSG5)	
X	L	L	VH
X	L	H	VM
X	H	L	VL
X	H	H	VL

Table 28. V3B Output Polarity

LEGEN	Vertical Driver Input			V3B Output
	XV3	XV23	XV21 (XSG6)	
L	L	X	L	VH
L	L	X	H	VM
L	H	X	L	VL
L	H	X	H	VL
H	X	L	L	VH
H	X	L	H	VM
H	X	H	L	VL
H	X	H	H	VL

Table 29. V4 Output Polarity

LEGEN	Vertical Driver Input		V4 Output
	XV4	XV22 (XSG7)	
X	L	L	VH
X	L	H	VM
X	H	L	VL
X	H	H	VL

Table 30. V5 Output Polarity

LEGEN	Vertical Driver Input			V5 Output
	XV5	XV23 (XSG8)	GPO5 (XSG8)	
L	L	L	X	VH
L	L	H	X	VM
L	H	L	X	VL
L	H	H	X	VL
H	L	X	L	VH
H	L	X	H	VM
H	H	X	L	VL
H	H	X	H	VL

Table 31. V6 Output Polarity

LEGEN	Vertical Driver Input			V6 Output
	XV6	XV24 (XSG9)	GPO6 (XSG9)	
L	L	L	X	VH
L	L	H	X	VM
L	H	L	X	VL
L	H	H	X	VL
H	L	X	L	VH
H	L	X	H	VM
H	H	X	L	VL
H	H	X	H	VL

Table 32. V7 Output Polarity

LEGEN	Vertical Driver Input		V7 Output
	XV7		
X	L		VM
X	H		VL

Table 33. V8 Output Polarity

LEGEN	Vertical Driver Input		V8 Output
	XV8		
X	L		VM
X	H		VL

Table 34. V9 Output Polarity

LEGEN	Vertical Driver Input		V9 Output
	XV9		
X	L		VM
X	H		VL

# AD9920A

Table 35. V10 Output Polarity

LEGEN	Vertical Driver Input	V10 Output
	XV10	
X	L	VM
X	H	VL

Table 36. V11 Output Polarity

LEGEN	Vertical Driver Input	V11 Output
	XV11	
X	L	VM
X	H	VL

Table 37. V12 Output Polarity

LEGEN	Vertical Driver Input	V12 Output
	XV12	
X	L	VM
X	H	VL

Table 38. V13 Output Polarity

LEGEN	Vertical Driver Input	V13 Output
	XV13	
X	L	VM
X	H	VL

Table 39. V14 Output Polarity

LEGEN	Vertical Driver Input	V14 Output
	XV14	
X	L	VM
X	H	VL

Table 40. V15 Output Polarity

LEGEN	Vertical Driver Input	V15 Output
	XV15	
X	L	VM
X	H	VL

Table 41. V16 Output Polarity

LEGEN	Vertical Driver Input	V16 Output
	XV24	
L	X	VL
H	L	VM
H	H	VL

Table 42. SUBCK Output Polarity

LEGEN	Vertical Driver Input		SUBCK Output
	XSUBCK	XSUBCNT	
X	L	L	VH
X	L	H	VH
X	H	L	VMM
X	H	H	VLL

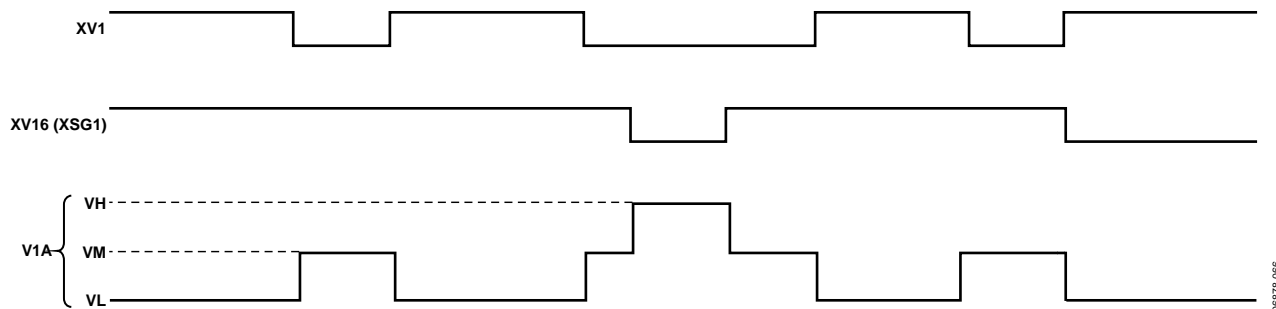

Figure 67. XV1, XV16, and V1A Output Polarities

06878-066

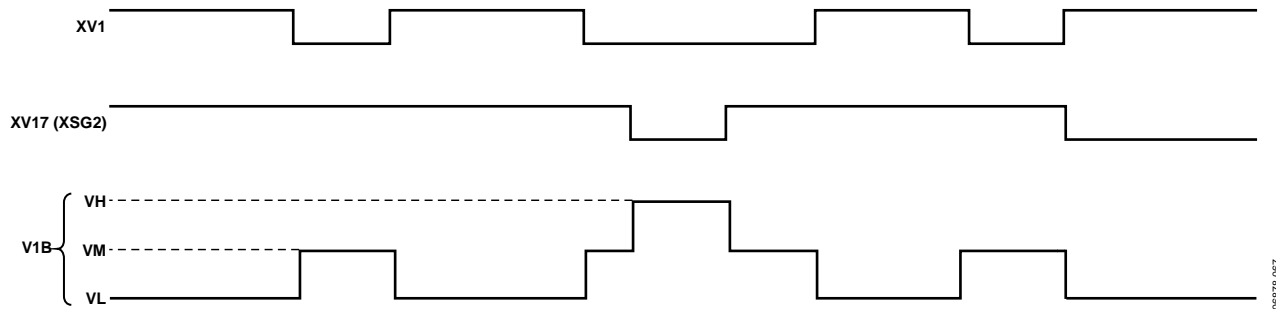

Figure 68. XV1, XV17, and V1B Output Polarities

06878-067

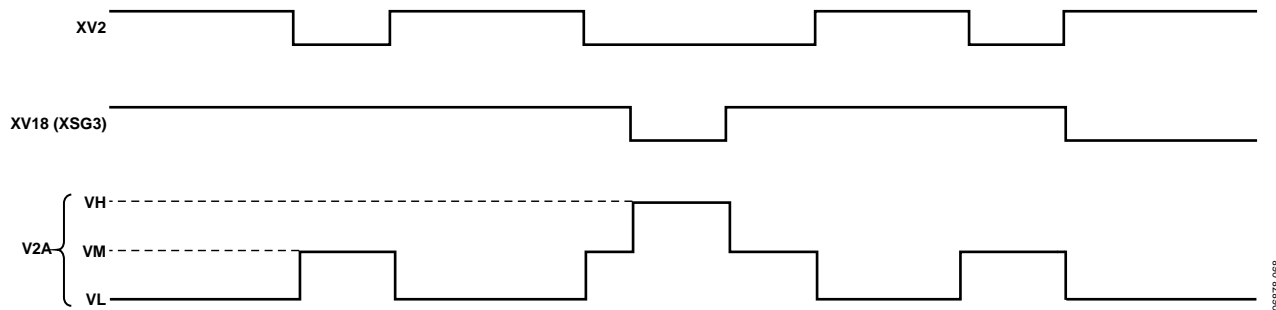

Figure 69. XV2, XV18, and V2A Output Polarities

06878-068

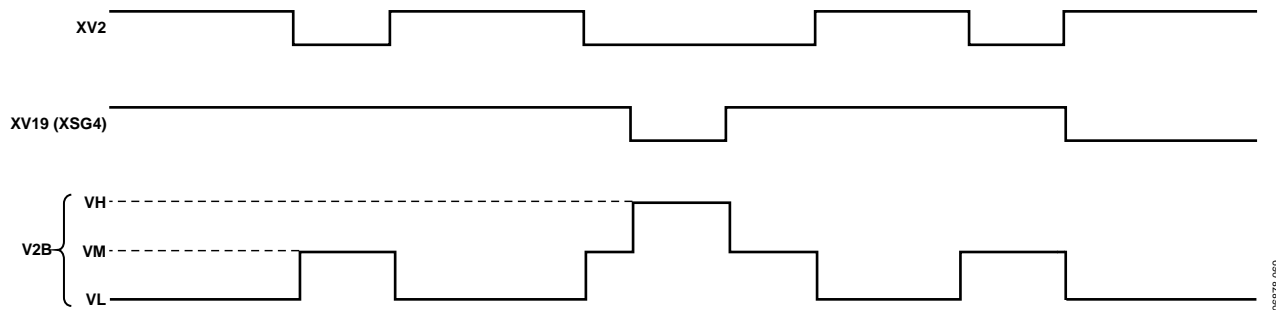

Figure 70. XV2, XV19, and V2B Output Polarities

06878-069

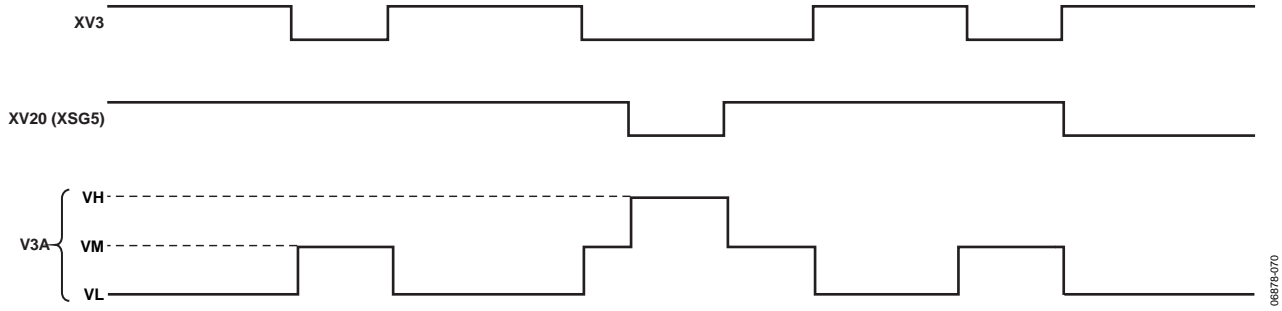

Figure 71. XV3, XV20, and V3A Output Polarities

06878-070

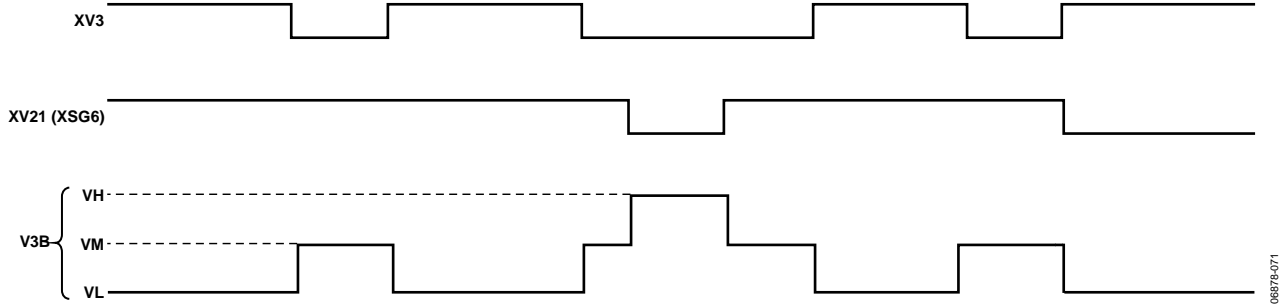

Figure 72. XV3, XV21, and V3B Output Polarities ( $\overline{\text{LEGEN}} = \text{Low}$ )

06878-071

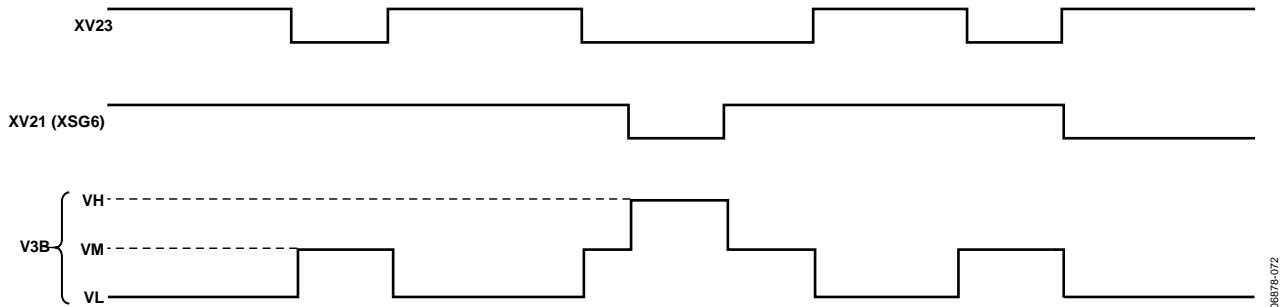

Figure 73. XV23, XV21, and V3B Output Polarities ( $\overline{\text{LEGEN}} = \text{High}$ )

06878-072

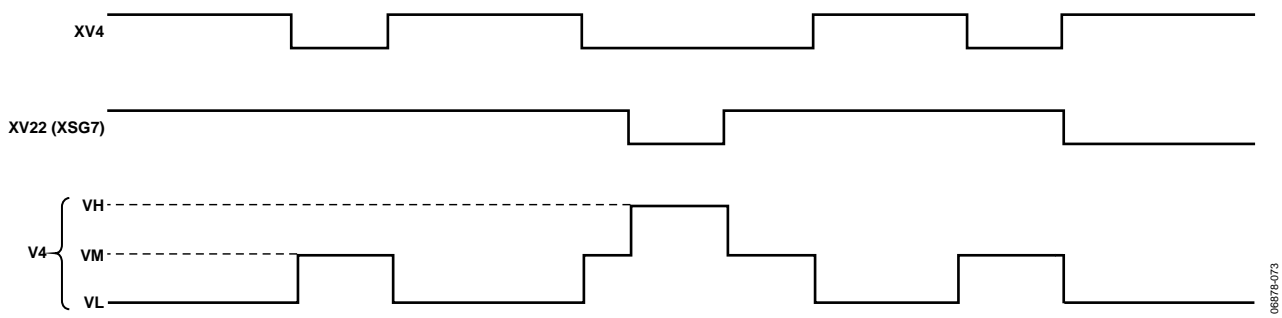

Figure 74. XV4, XV22, and V4 Output Polarities

06878-073

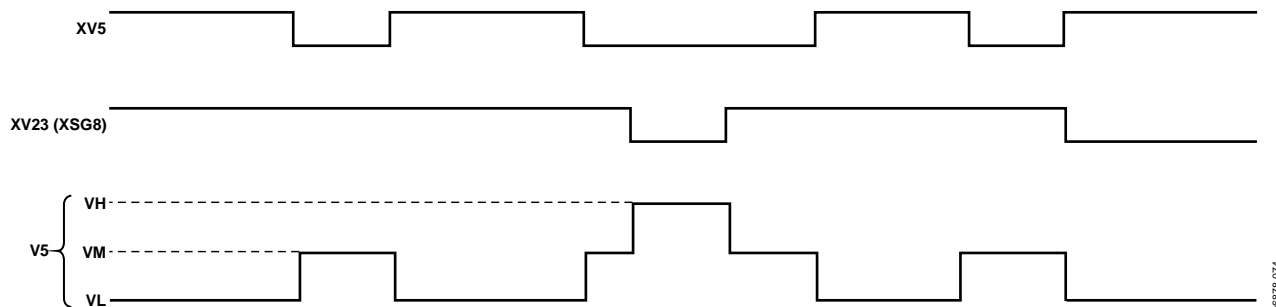

Figure 75. XV5, XV23, and V5 Output Polarities ( $\overline{\text{LEGEN}} = \text{Low}$ )

06878-074

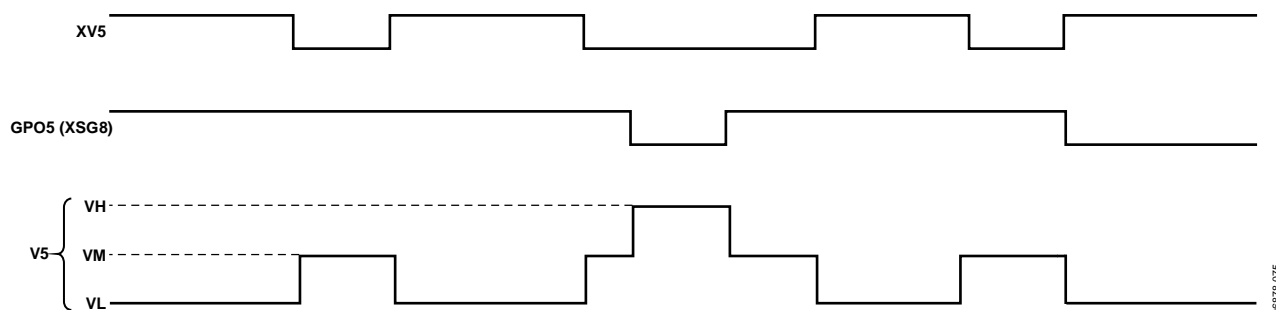

Figure 76. XV5, GPO5, and V5 Output Polarities ( $\overline{\text{LEGEN}} = \text{High}$ )

06878-075

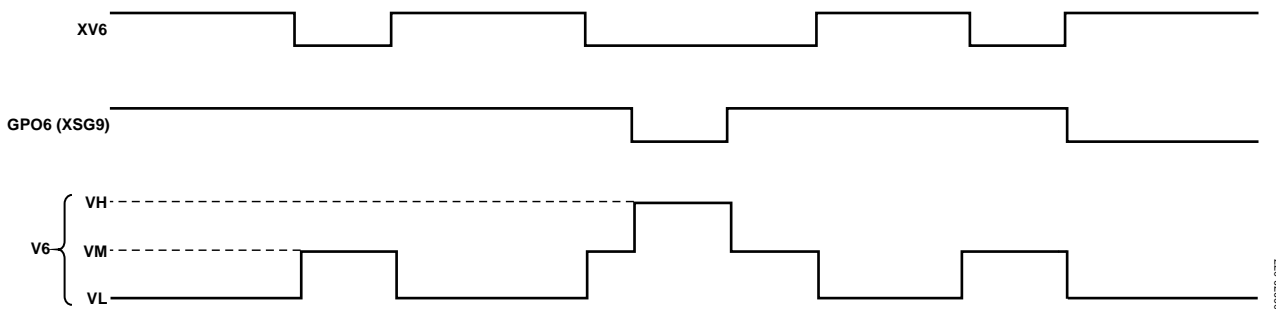

Figure 77. XV6, GPO6, and V6 Output Polarities ( $\overline{\text{LEGEN}} = \text{High}$ )

06878-077

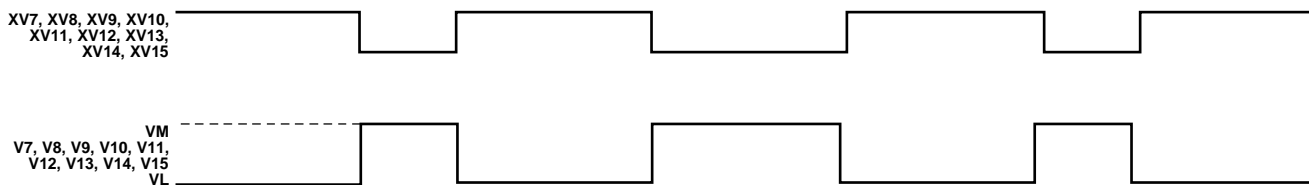

Figure 78. Two-Level V-Driver Output Polarities

06878-078

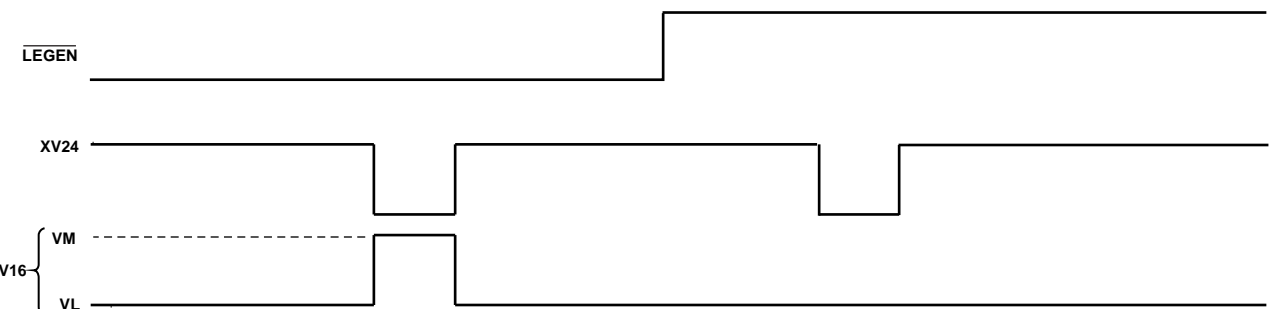

Figure 79. XV24 and V16 Output Polarities

06878-079

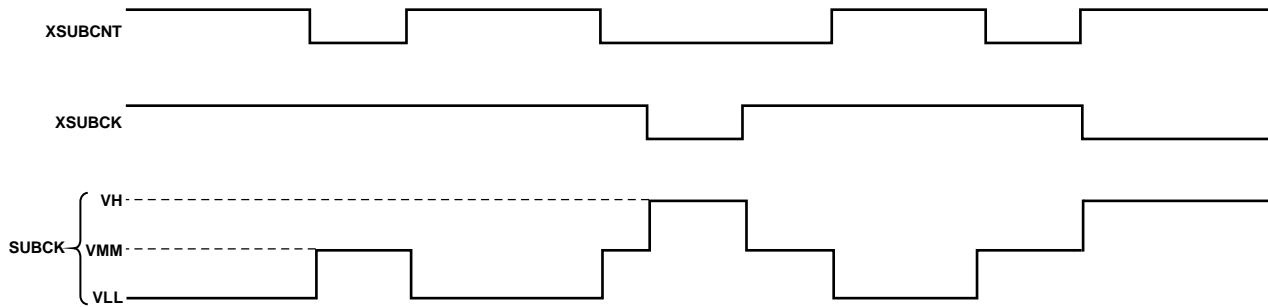

Figure 80. XSUBCNT, XSUBCK, and SUBCK Output Polarities

06879-080

## V-DRIVER SLEW RATE CONTROL

The AD9920A allows the user to moderate the slew rates of the V-driver outputs when transitioning to VM and VL (this feature does not affect transitions to VH). This feature minimizes coupling from V-driver activity that occurs while the AD9920A is clocking valid image pixel data out of the CCD.

There are both coarse and fine mechanisms for controlling the slew rate of the V1A to V13 outputs. If SRSW = VDD and SRCTL = VDD, the V1A to V13 switches have roughly 10% of their normal drive strength (that is, when SRSW = VSS). If SRSW = VDD and SRCTL < VDD, the voltage applied to SRCTL controls the slew rate for V1A to V13 transitions from VM to VL and from VL to VM. For values from 800 mV to VDD, V1A to V13 transition at a fraction of their maximum slew rate that is roughly proportional to the voltage applied to SRCTL. (It is not recommended that voltages less than 800 mV be applied to SRCTL.)

The user must tune this voltage for the specific system to determine the optimal setting that ensures maximum charge transfer efficiency and minimizes any coupling from V-driver activity into the image. V14, V15, and V16 are permanently weak compared with V1A to V13 and are not affected by the slew rate control function. Note that the slew rate control feature is intended only for use with CCDs that require V-driver activity outside the normal horizontal clock blanking region.

## SHUTTER TIMING CONTROL

The AD9920A supports the generation of electronic shuttering (SUBCK) and also features flexible general-purpose outputs (GPOs) to control mechanical shuttering, CCD substrate bias switching, and strobe circuitry. In the following sections, the terms sense gate (SG) and vertical sense gate (VSG) are used interchangeably.

## SUBSTRATE CLOCK OPERATION (SUBCK)

The CCD image exposure time is controlled by the substrate clock signal (SUBCK), which pulses the CCD substrate to clear out accumulated charge. The AD9920A supports three types of electronic shuttering: normal, high precision, and low speed. Along with the SUBCK pulse placement, the AD9920A can accommodate different readout configurations to further suppress the SUBCK pulses during multiple field readouts.

The SUBCK signal is a programmable string of pulses, each occupying a line following the primary sense gate active line, SGACTLINE1 (see Table 43). The SUBCK signal has programmable pulse width, line placement, and number of pulses to accurately control the exposure time.

### SUBCK Normal Operation

By default, the AD9920A operates in the normal SUBCK configuration, in which the SUBCK signal is pulsing in every VD field (see Figure 81). The SUBCK pulse occurs once per line, and the total number of repetitions within the field determines the length of the exposure time. The SUBCK pulse polarity and toggle positions within a line are programmable using the SUBCK\_POL and SUBCK\_TOG1 registers (see Table 43). The number of SUBCK pulses per field is programmed in the SUBCKNUM register (Address 0x75).

As shown in Figure 81, the SUBCK pulses always begin in the line following the SG active line, which is specified in the SGACTLINE registers for each field. The SUBCK\_POL, SUBCK\_TOG1, SUBCK\_TOG2, SUBCKNUM, and SUBCKSUPPRESS registers are updated at the start of the line after the sensor gate line, as described in the Updating New Register Values section.

### ***SUBCK High Precision Operation***

High precision shuttering is used in the same manner as normal shuttering, but it uses an additional register to control the last SUBCK pulse. In this mode, the SUBCK still pulses once per line, but the last SUBCK in the field has an additional SUBCK pulse, whose location is determined by the SUBCKHP\_TOG registers, as shown in Figure 82. Finer resolution of the exposure time is possible using this mode. Leaving the SUBCKHP\_TOG registers set to their maximum value (0xFFFFF) disables the last SUBCK pulse (default setting).

### ***SUBCK Low Speed Operation***

Normal and high precision shutter operations are used when the exposure time is less than one field. For exposure times greater than one field, the low speed (LS) shutter features can be used. The AD9920A includes a field counter (primary field counter) to regulate long exposure times. The primary field counter (Address 0x70) must be activated to serve as the trigger for the LS operation. The durations of the LS exposure and read are specified by the SGMASK\_NUM and SUBCKMASK\_NUM registers (Address 0x74), respectively. As shown in Figure 83, this mode suppresses the SUBCK and VSG outputs for up to 8192 fields (VD periods).

To activate an LS shutter operation, trigger the start of the exposure by writing to the PRIMARY\_ACTION register bits according to the desired effect (see Table 59). When the primary counter is activated, the next VD period becomes the first active period of the exposure for which the VSG and SUBCK masks are applied.

Optionally, if the SUBCKMASK\_SKIP1 register is enabled, the AD9920A ignores the first VSG and SUBCK masks in the subsequent fields. This is generally desired so that the exposure time begins in the field after the exposure operation is initiated. Figure 83 shows operation with SUBCKMASK\_SKIP1 = 1. The same functionality can also be achieved using the PRIMARY\_DELAY register along with the PRIMARY\_ACTION register.

If the PRIMARY\_ACTION register is used while the SUBCKMASK\_NUM and SGMASK\_NUM registers are set to 0, the behavior of the SUBCK and VSG signals is not different from the normal shutter or high precision shutter operations. Therefore, the primary field counter can be used for other tasks (described in the General-Purpose Outputs (GPOs) section) without disrupting normal activity. In addition, a secondary field counter is available that has no effect on the SUBCK and VSG signals. These counters are described in detail in the Field Counters section.

### ***SUBCKSUPPRESS Register***

By default, the SUBCK pulses begin in the line following SGMASK\_NUM. For applications where the SUBCK pulse should be suppressed for one or more lines following the VSG line, the SUBCKSUPPRESS register can be programmed. This register setting delays the start of the SUBCK pulses until the specified number of lines following SGMASK\_NUM.

### ***Read After Exposure***

To read the CCD data after exposure, the SG should resume normal activity while the SUBCK remains null. By default, the AD9920A generates the VSG pulses in every field. When only a single exposure and a single frame read are desired, as in the case of preview mode, the VSG and SUBCK pulses can operate in every field.

Other applications require that a greater number of frames be read, in which case SUBCK must be masked until the readout is finished. The SUBCKMASK\_NUM register specifies the total number of fields (exposure and read) to mask SUBCK. A two-field CCD frame read mode typically requires two additional fields of SUBCK masking (SUBCKMASK\_NUM = 2). A three-field, 6-phase CCD requires three additional fields of SUBCK masking after the read begins (SUBCKMASK\_NUM = 3).

Note that the SUBCKMASK\_SKIP1 register setting allows SUBCK pulses at the beginning of the field of exposure.

**Table 43. SUBCK and Exposure/Read Register Parameters**

<b>Register</b>	<b>Length (Bits)</b>	<b>Range</b>	<b>Description</b>
SGMASK_NUM	13	0 to 8191 number of fields	Exposure duration (number of fields to suppress VSG) for LS operation.
SUBCKMASK_NUM	13	0 to 8191 number of fields	Exposure plus readout duration (number of fields to suppress SUBCK) for LS.
SUBCKMASK_SKIP1	1	On/off	Suppress SG/SUBCK masks for one field (default = 0). Typically set to 1.
SUBCKSUPPRESS	13	0 to 8191 lines	Number of lines to suppress the start of SUBCK pulses after SGMASK_NUM.
SUBCKNUM	13	1 to 8191 number of pulses	Total number of SUBCK pulses per field, at one pulse per line.
SG_SUPPRESS	1	On/off	Suppress the SG and allow SUBCK to finish at SUBCKNUM.
SUBCK_TOG1	14	0 to 16383 pixel locations	SUBCK Toggle Position 1.
SUBCK_TOG2	14	0 to 16383 pixel locations	SUBCK Toggle Position 2.
SUBCK_POL	1	Low/high	SUBCK start polarity.
SUBCKHP_TOG1	14	0 to 16383 pixel locations	High precision SUBCK Toggle Position 1. Selectable as SG or VD updated.
SUBCKHP_TOG2	14	0 to 16383 pixel locations	High precision SUBCK Toggle Position 2. Selectable as SG or VD updated.

# AD9920A

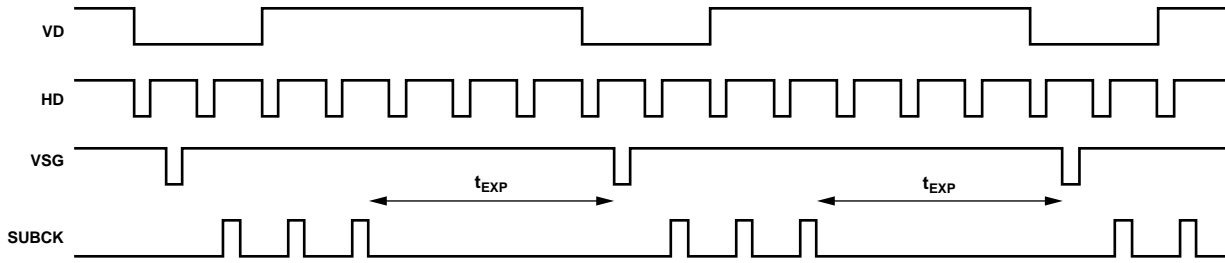

**SUBCK PROGRAMMABLE SETTINGS:**

1. PULSE POLARITY USING THE SUBCK\_POL REGISTER.
2. NUMBER OF PULSES WITHIN THE FIELD USING THE SUBCKNUM REGISTER (SUBCKNUM = 3 IN THIS EXAMPLE).
3. PIXEL LOCATION OF PULSE WITHIN THE LINE AND PULSE WIDTH PROGRAMMED USING THE SUBCK\_TOG1 TOGGLE POSITION REGISTER.

Figure 81. Normal SUBCK Operation

068776-081

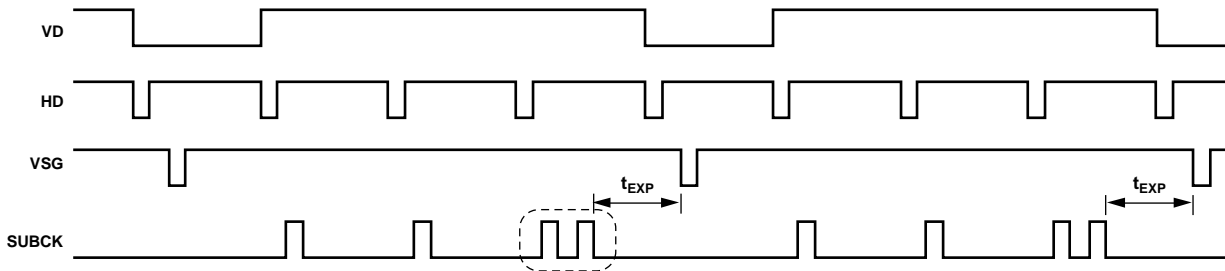

**NOTES**

1. SECOND SUBCK PULSE IS ADDED IN THE LAST SUBCK LINE.
2. LOCATION OF SECOND PULSE IS FULLY PROGRAMMABLE USING THE SUBCKHP TOGGLE POSITION REGISTERS.

Figure 82. High Precision SUBCK Operation

068776-082

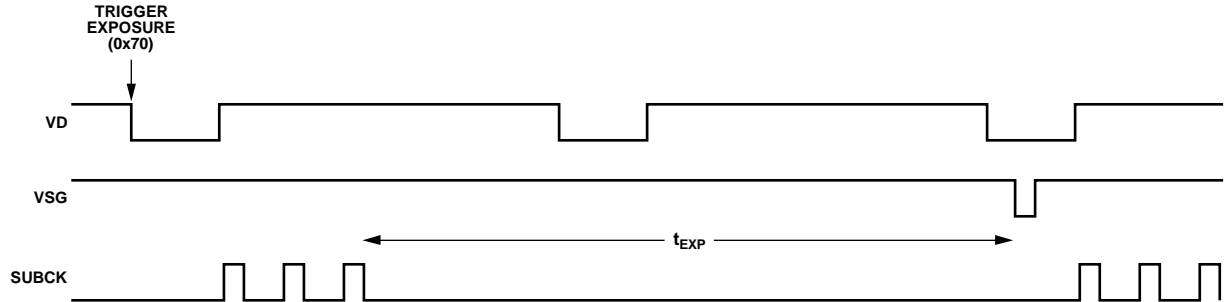

**NOTES**

1. SUBCK CAN BE SUPPRESSED FOR MULTIPLE FIELDS BY PROGRAMMING THE EXPOSURE REGISTER TO BE GREATER THAN 0.
2. THIS EXAMPLE USES EXPOSURE = 1.
3. TRIGGER REGISTER MUST ALSO BE USED TO START THE LOW SPEED EXPOSURE.
4. VD/HD OUTPUTS CAN ALSO BE SUPPRESSED USING THE VDHD\_MASK REGISTER = 1.

Figure 83. Low Speed SUBCK Operation (SUBCKMASK\_SKIP1 = 1)

068776-083

## FIELD COUNTERS

The AD9920A contains three field counters (primary, secondary, and mode). When these counters are active, they increment with each VD cycle. The mode counter is the field counter used with the mode register to control the vertical timing signals (see the Mode Registers section).

The primary and secondary counters are more flexible and are generally used for shuttering signal applications. Both the primary and secondary counters have several modes of operation that are selected by Address 0x70. These modes are as follows:

- Normal (single count)
- RapidShot (repeating count)
- ShotTimer (delayed count)

- ShotTimer with RapidShot
- Manual exposure
- Manual readout
- Force to idle

The primary counter regulates the expose and read actions by regulating the SUBCK and VSG signals. In addition, if the RapidShot feature is used with the primary counter, the SUBCK and VSG masking automatically repeats as necessary for multiple expose/read cycles. The secondary counter has no effect on the SUBCK or VSG signal. Both counters can be used to regulate the general-purpose signals described in the General-Purpose Outputs (GPOs) section.

**Table 44. Primary/Secondary Field Counter Registers (Address 0x70, Address 0x71, and Address 0x72)**

Register	Length (Bits)	Description
PRIMARY_ACTION	3	0 = idle, no counter action. GPO signals can still be controlled using polarity or by setting the appropriate GP_PROTOCOL register to 1.
SECOND_ACTION	3	1 = activate counter. Single cycle of counter from 1 to counter maximum value and then return to idle state. 2 = RapidShot. After reaching the maximum counter value, the counter wraps and repeats until reset. 3 = ShotTimer. Active single cycle of counter after added delay of n fields (use the corresponding DELAY register). 4 = ShotTimer with RapidShot. Same as RapidShot (SECOND_ACTION register = 2) but with an added delay of n fields between each repetition. 5 = manual exposure. Primary counter stays in exposure until manual readout or reset to idle. This mode keeps the SUBCK and VSG pulses masked indefinitely. 6 = manual readout. Primary counter switches to readout (VSG pulses becomes active). 7 = force to idle.
PRIMARY_MAX	13	Primary counter maximum value.
SECOND_MAX	12	Secondary counter maximum value.
VDHD_MASK	3	Mask VD/HD during counter operation.
PRIMARY_DELAY	13	ShotTimer. Number of fields to delay before the next primary count (exposure) starts. If using ShotTimer with RapidShot, the delay value is used between each repetition.
PRIMARY_SKIP	1	When using ShotTimer with RapidShot, use the primary delay value only before the first count (exposure).
SECOND_DELAY	13	ShotTimer. Number of fields to delay before the next secondary count starts. If using ShotTimer with RapidShot, the delay value is used between each repetition.
SECOND_SKIP	1	When using ShotTimer with RapidShot, use the secondary delay value only before the first count.

# AD9920A

## GENERAL-PURPOSE OUTPUTS (GPOs)

The AD9920A provides programmable outputs to control a mechanical shutter, the strobe/flash, the CCD bias select signal, or any other external component with general-purpose (GP) signals. Eight GP signals, with up to four toggles each, are available to be programmed and assigned to special GPO pins. These pins are bidirectional and allow visibility (as an output) and external control (as an input) of HBLK, PBLK, CLPOB, and OUT\_CONTROL. The GPO registers are described in Table 45.

Note that GPO5 and GPO6 are used to control the SG signals for the V5 and V6 outputs of the AD9920A. See the SG Control Using GPO section for more information.

### GP Toggles

When configured as an output, each GPO output can deliver a signal that is the result of programmable toggle positions. The GP signals are independent and can be linked to a specific VD period or to a range of VD periods via the primary or secondary field counters through the GP protocol register (Address 0x73). As a result of their associations with the field counters, the GP toggles inherit the characteristics of the field counters, such as RapidShot and ShotTimer.

To program the GP toggles, complete the following steps:

1. Program the toggle positions (Address 0x7C to Address 0xAB).
2. Program the GP protocol (Address 0x73).

3. Program the counter parameters (Address 0x71 to Address 0x72).
4. Activate the counter (Address 0x70).

For Protocol 1 (no counter association), skip Step 3 and Step 4.

With these four steps, the GP signals can be programmed to accomplish many common tasks. Careful protocol selection and application of the field counters yields efficient results to allow the GP signals smooth integration with concurrent operations.

Note that the SUBCK and VSG masks are linked to the primary counter; however, if their parameters are 0, the GPO can use the primary counter without expose/read activity.

The secondary counter is independent and can be used simultaneously with the primary counter. Some applications may require the use of both primary and secondary field counters with different GPO protocols, start times, and durations. Such operations are easily handled by the AD9920A.

Several simple examples of GPO applications using only one GPO and one field counter follow. These examples can be used as building blocks for more complex GPO activity. In addition, specific GPO signals can be passed through a four-input lookup table (LUT) to realize combinational logic between them. For example, GP1 and GP2 can be sent through an XOR lookup table, and the result can be delivered on GP1, GP2, or both. In addition, GP1 or GP2 can deliver its original toggles.

**Table 45. GPO Registers**

Register	Length (Bits)	Range	Description
GP1_PROTOCOL	3	0 to 7	0 = idle
GP2_PROTOCOL	3	0 to 7	1 = no counter association; use MANUAL_TRIG bits to enable each GP signal.
GP3_PROTOCOL	3	0 to 7	2 = test only.
GP4_PROTOCOL	3	0 to 7	3 = test only.
GP5_PROTOCOL	3	0 to 7	4 = link to mode counter (from vertical timing generation).
GP6_PROTOCOL	3	0 to 7	5 = link to primary counter (also allows GP signals to repeat with RapidShot).
GP7_PROTOCOL	3	0 to 7	6 = link to secondary counter (also allows GP signals to repeat with RapidShot).
GP8_PROTOCOL	3	0 to 7	7 = keep on.
MANUAL_TRIG	8	On/off	Manual trigger for each GP signal. For use with Protocol 1.
GP[1:8]_POL	8	Low/high	Starting polarity for GP signals. Only updated when GPx_PROTOCOL = 0.
SEL_GP[1:8]	8	On/off	1 = select GP toggles visible at GPO1 to GPO4, GPO7, and GPO8 when output is enabled (default). 0 = select vertical signals visible at GPO4 to GPO8 when output is enabled. GPO4: XSUBCK. GPO5: XV21. GPO6: XV22. GPO7: XV23. GPO8: XV24.
GPO_OUTPUT_EN	8	On/off	1 = enable GPO1 to GPO4, GPO7, and GPO8 outputs (one bit per output). 0 = disable GPO1 to GPO4, GPO7, and GPO8 outputs; pins are high-Z (default).
GPx_USE_LUT	8	On/off	Send GP signals through a programmable lookup table (LUT).
LUT_FOR_GP12	4	Logic setting	Desired logic to be realized on GPO1 combined with GPO2.
LUT_FOR_GP34	4	Logic setting	Desired logic to be realized on GPO3 combined with GPO4.
LUT_FOR_GP56	4	Logic setting	Desired logic to be realized on GPO5 combined with GPO6.

Register	Length (Bits)	Range	Description
LUT_FOR_GP78	4	Logic setting	Desired logic to be realized on GPO7 combined with GPO8. Example logic settings for LUT_FOR_GPxy: 0x06 = GPy XOR GPx (see Figure 89). 0x07 = GPy NAND GPx. 0x08 = GPy AND GPx. 0x0E = GPy OR GPx.
GPx_TOGx_FD	13	0 to 8191 fields	Field of activity, relative to primary and secondary counter for corresponding toggle.
GPx_TOGx_LN	13	0 to 8191 lines	Line of activity for corresponding toggle.
GPx_TOGx_PX	13	0 to 8191 pixels	Pixel of activity for corresponding toggle.
GPO_INT_EN	1	On/off	When set to 1, internal signals are viewable on GPO1 to GPO3. Also, set the SEL_GPx bit low to output internal signals. GPO1 = internal clock. GPO2 = CLPOB. GPO3 = delayed sample clock.

# AD9920A

## Single-Field Toggles

Single-field toggles occur in the next field only. There can be up to four toggles in the field. The mode is set with GP\_PROTOCOL equal to 1, and the toggles are triggered in the next field by writing to the MANUAL\_TRIG register (Register 0x70, Bits[13:6]). In this mode, the field toggle settings must be set to a value of 1. Two consecutive fields do not have activity. If toggles are required to repeat in the next field, the MANUAL\_TRIG register can be written to in consecutive fields.

### Preparation

The GP toggle positions can be programmed any time prior to use. For example,

```
0x7C ← 0x000A001
0x7D ← 0x0002000
0x7E ← 0x000000F
0x7F ← 0x00C4002
0x80 ← 0x0004000
0x81 ← 0x00000B3
```

### Details

A) Field 0:        0x70 ← 0x0000040  
                       0x73 ← 0x0000001  
 B) Field 1:        0x73 ← 0x0000000

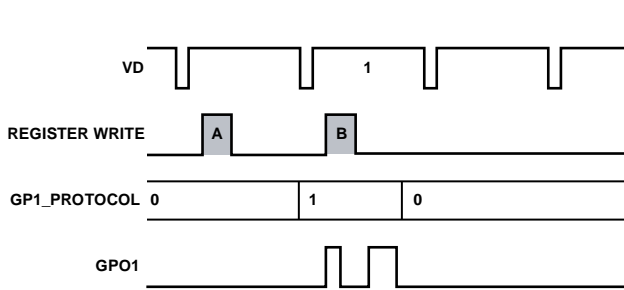

**NOTES**  
 1. THE FIELD TOGGLE POSITION MUST BE SET TO 1 WHEN GP\_PROTOCOL IS 1.  
 CAUTION! THE GP\_PROTOCOL MUST BE RESET BEFORE USING AGAIN.

06878-084

Figure 84. Single-Field Toggles Using GP\_PROTOCOL = 1

## Scheduled Toggles

Scheduled toggles are programmed to occur during upcoming fields. For example, there can be one toggle in Field 1, two toggles in Field 3, and a last toggle in Field 4. The mode is set with GP\_PROTOCOL = 5 or GP\_PROTOCOL = 6. Mode 5 tells the GPO to obey the primary field counter, and Mode 6 tells the GPO to obey the secondary field counter.

Note that for GP\_PROTOCOL = 5 or GP\_PROTOCOL = 6, at least one toggle must be programmed in Field 1 for the AD9920A to output the proper pattern on the GPO pins. If no toggle is programmed in Field 1, all subsequent toggle positions are ignored when GP\_PROTOCOL = 5 or GP\_PROTOCOL = 6. This restriction applies only to GP\_PROTOCOL = 5 or GP\_PROTOCOL = 6.

### Preparation

The GP toggle positions can be programmed any time prior to use. For example,

```
0x7C ← 0x00C4001
0x7D ← 0x0004000
0x7E ← 0x00000B3
```

### Details

A) Field 0:        0x70 ← 0x0000008  
                       0x73 ← 0x0000006

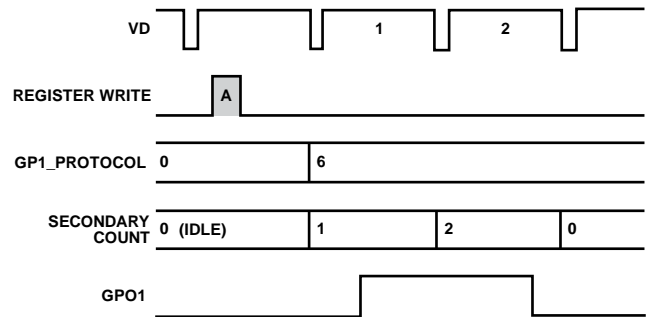

**CAUTION! THE PRIMARY COUNTER REGULATES THE SUBCK AND VSG ACTIVITY. LINK A GPO TO THE PRIMARY COUNTER ONLY IF SUBCK AND VSG ACTIVITY WILL OCCUR DURING EXPOSURE/READ.**

06878-085

Figure 85. Scheduled Toggles Using GP\_PROTOCOL = 6

**RapidShot Sequences**

RapidShot technology provides continuous repetition of scheduled toggles.

**Preparation**

The GP toggle positions can be programmed any time prior to use. For example,

- 0x71 ← 0x0004000
- 0x7C ← 0x000A001
- 0x7D ← 0x0002000
- 0x7E ← 0x000000F
- 0x7F ← 0x00C4002
- 0x80 ← 0x0004000
- 0x81 ← 0x00000B3
- 0x73 ← 0x0000006

**Details**

- A) Field 0: 0x70 ← 0x0000010
- B) Field 2: 0x70 ← 0x0000007

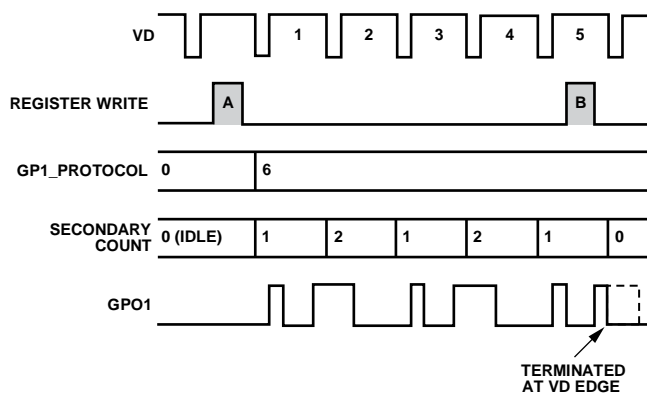

CAUTION! THE FIELD COUNTER MUST BE FORCED INTO IDLE STATE TO TERMINATE REPETITIONS.

Figure 86. RapidShot Toggle Operation Using GP\_PROTOCOL = 6

06873-086

**ShotTimer Sequences**

ShotTimer technology provides internal delay of scheduled toggles. The delay is in terms of fields.

**Preparation**

The GP toggle positions can be programmed any time prior to use. For example,

- 0x71 ← 0x0004000
- 0x72 ← 0x000C000
- 0x7C ← 0x000A001
- 0x7D ← 0x0002000
- 0x7E ← 0x000000F
- 0x73 ← 0x0000006

**Details**

- A) Field 0: 0x70 ← 0x0000018

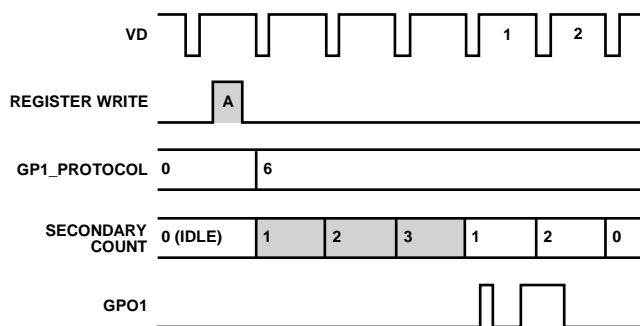

Figure 87. ShotTimer Toggle Operation Using GP\_PROTOCOL = 6

06874-087

## GP LOOKUP TABLE (LUT)

The AD9920A is equipped with a lookup table for each pair of consecutive GP signals when configured as outputs. GPO1 is always combined with GPO2, GPO3 is always combined with GPO4, GPO5 is always combined with GPO6, and GPO7 is always combined with GPO8. The external GPO outputs from each pair can output the result of the LUT or the original GP internal signal.

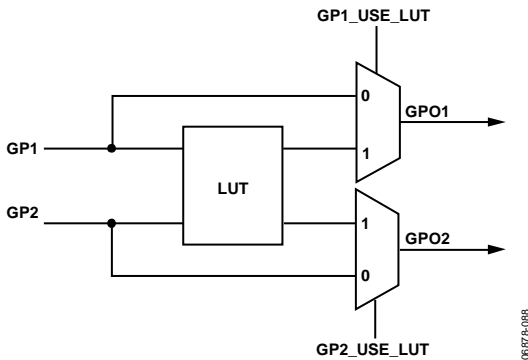
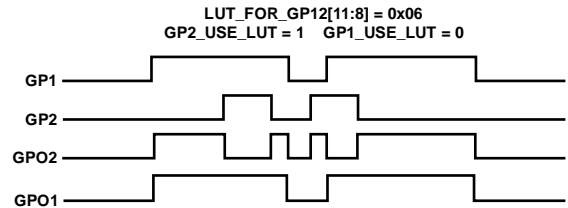

Figure 88. Internal LUT for GPO1 and GPO2 Signals

Address 0x7B configures the behavior of the LUT and which signals receive the result. Each 4-bit LUT\_FOR\_GPxy register can realize any logic combination of GPx and GPy. For example, Table 46 shows how the register values of LUT\_FOR\_GP12, Bits[11:8], are determined. XOR, NAND, AND, and OR results are shown, but any 4-bit combination is possible. A simple example of XOR gating is shown in Figure 89.

Table 46. LUT Results Based on GP1 and GP2 Values

GP2	GP1	LUT: XOR	LUT: NAND	LUT: AND	LUT: OR
0	0	0	1	0	0
0	1	1	1	0	1
1	0	1	1	0	1
1	1	0	0	1	1



NOTES  
1. LOGIC COMBINATION (XOR) OF PROGRAMMED TOGGLES GP1 AND GP2.

Figure 89. LUT Example for GP1 XOR GP2

## Field Counter and GPO Limitations

The following is a summary of the known limitations of the field counters and GPO signals.

- The field counter trigger (PRIMARY\_ACTION and SECOND\_ACTION registers, Address 0x70) is automatically reset at the start of every VD period. Therefore, there must be one VD period between sequential programming to that address.
- If GPx\_PROTOCOL = 1, it must be manually reset to GPx\_PROTOCOL = 0 one VD period before it can be used again. If manual toggles are desired in sequential fields, the MANUAL\_TRIG register should be used in conjunction with GPx\_PROTOCOL = 1.

## COMPLETE EXPOSURE/READOUT OPERATION USING PRIMARY COUNTER AND GPO SIGNALS

Figure 90 illustrates a typical expose/read cycle while exercising the GPO signals. Using a three-field CCD with an exposure time that is greater than one field but less than two fields in duration requires a total of five fields for the entire exposure/readout operation. Other exposure times and CCD field configurations require modification of these example settings.

Note that if the mode registers are changed to be VD updated, as shown in the Mode Registers section and in Figure 63, the mode update is delayed by one additional field. This should be accounted for in selecting the number of fields to cycle and in determining which VD location to write to the mode registers.

1. The primary counter is used to control the masking of VSG and SUBCK during exposure/readout. The PRIMARY\_MAX register (Address 0x71) should be set equal to the total number of fields used for exposure and readout. In this example, PRIMARY\_MAX = 5.

The SUBCK masking should not occur immediately at the next VD edge (Step 2) because this would define an exposure time that begins in the previous field. Write to the PRIMARY\_DELAY register (Address 0x72) to delay the masking of VSG and SUBCK pulses in the first exposure field. In this example, PRIMARY\_DELAY = 1.

Write to the SUBCKMASK\_NUM register (Address 0x74) to specify the number of fields to mask SUBCK while the CCD data is read. In this example, SUBCKMASK\_NUM = 4.

Write to the SGMASK\_NUM register (Address 0x74) to specify the number of fields to mask VSG outputs during exposure. In this example, SGMASK\_NUM = 1.

Write to the PRIMARY\_ACTION register (Address 0x70) to trigger the GP1 (STROBE), GP2 (MSHUT), and GP3 (VSUB) signals and to start the expose/read operation.

Write to the mode registers to configure the next five fields. The first two fields during exposure are the same as the current draft mode fields, and the following three fields are the still image frame readout fields. The register settings for the draft mode field and the three readout fields are previously programmed. Note that if the mode registers are changed to VD updated, only one field of exposure should be included (the second one) because the mode settings are delayed an extra field.

2. VD/HD falling edge updates the serial writes from 1.
3. GP3 (VSUB) output turns on at the field/line/pixel specified. In Figure 90, VSUB Example 1 and Example 2 use GP3TOG1\_FD = 1.
4. GP1 (STROBE) output turns on and off at the location specified.
5. GP2 (MSHUT) output turns off at the location specified.
6. The next VD falling edge automatically starts the first read field.
7. The next VD falling edge automatically starts the second read field.
8. The next VD falling edge automatically starts the third read field.
9. Write to the mode register to reconfigure the single draft mode field timing. Note that if the mode registers are changed to VD updated, this write should occur one field earlier.
10. VD/HD falling edge updates the serial writes from 9. VSG outputs return to draft mode timing. SUBCK output resumes operation. GP2 (MSHUT) output returns to the on position (active or open). GP3 (VSUB) output returns to the off position (inactive).

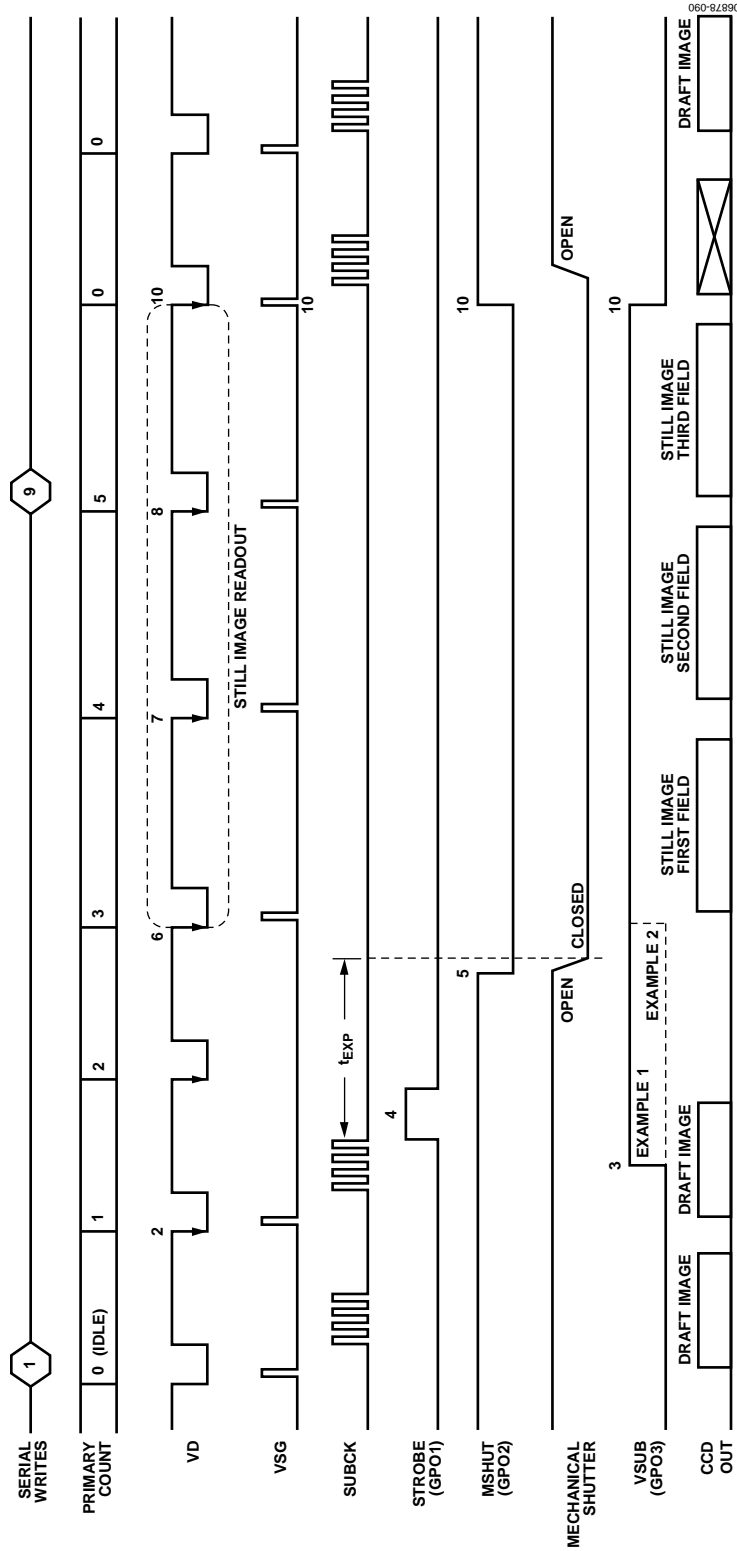

060-84890

Figure 90. Complete Exposure/Readout Operation Using Primary Counter and GPO Signals

### SG CONTROL USING GPO

The AD9920A uses two of the GPO signals to generate the SG signals for the three-level outputs V5 and V6. Because GPO5 and GPO6 are used as inputs to the vertical driver, they must be properly initialized at power-up to avoid incorrect V-driver output levels. During different CCD timing modes, the GPO signals can be controlled in several ways to produce the proper SG signal operation.

#### GPO5/GPO6 Power-Up Settings

GPO5 and GPO6 should be programmed with a polarity of high at power-up by setting the GP5\_POL and GP6\_POL bits (Address 0x7A, Bits[5:4]) equal to 11. This setting provides the correct polarity in the V-driver, because the XSG signals should be active low at the V-driver inputs. At power-up, the GPO5 and GPO6 outputs should also be enabled, by setting Register Address 0x7A, Bits[21:20] and Bits[13:12] all equal to 1, so that there is a defined state at all times.

#### Manual Control of GPO5

Figure 91 shows an example exposure/readout sequence of the AD9920A used in 18-channel mode without any GPO signals used for SG control. Figure 92 shows the 19-channel mode, with GPO5 used to control the SG signal for the V5 output. In this configuration, the GPO manual control method is used.

A serial write to the GP5\_PROTOCOL register is used to set the protocol of GPO5 equal to 1 (no counter association). The manual trigger bit for GPO5 (Address 0x70, Bit 10) is then written on the field previous to the field that requires the GPO5 (SG) signal. At the end of the readout, the GP5\_PROTOCOL register can be reset to 0 (idle).

#### Triggered Control of GPO5

Figure 93 shows the 19-channel mode, again with GPO5 used to control the SG signal for the V5 output. In this configuration, however, the secondary counter (scheduled toggles) method is used. A serial write to the GP5\_PROTOCOL register is used to set the protocol of GPO5 equal to 6 (link to secondary counter). At the start of the exposure, the field toggle location for GPO5 is programmed to the desired field count value to trigger the GPO5 signal. Then, the secondary counter is triggered. The secondary counter automatically increments and generates the GPO pulse in the proper field location during readout. At the end of the readout, the GPO5 protocol is automatically reset to idle.

The advantage of using the secondary counter is that no serial writes are required during exposure or readout, unlike the manual control method. The disadvantage is that more information must be programmed before the start of exposure, such as the exact field location where the GPO pulse is needed, taking into account the length of the exposure and readout fields.

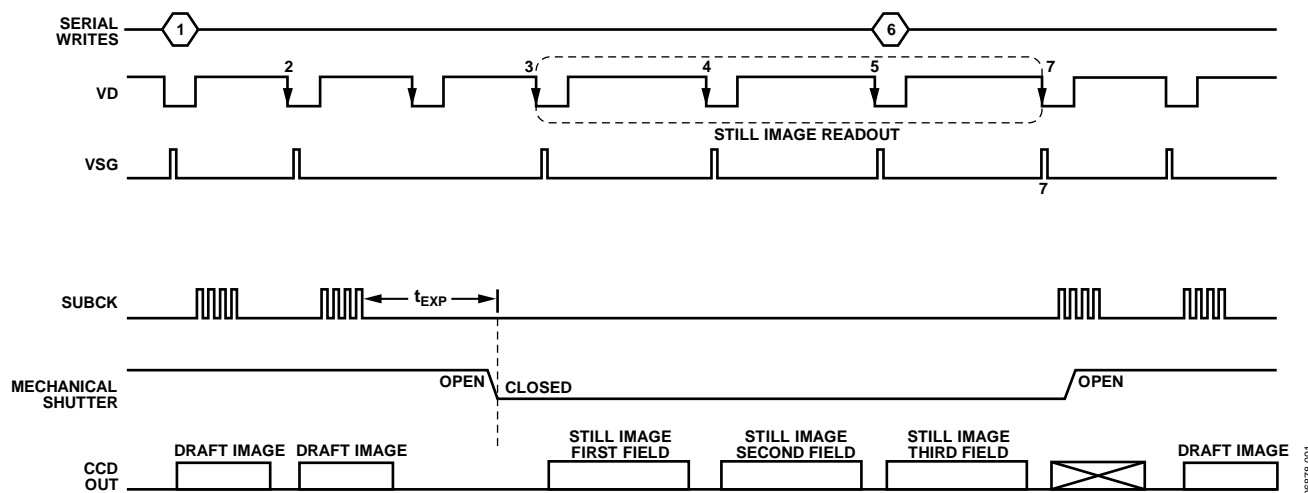

Figure 91. Exposure/Readout Operation Without Using GPO for SG Signal

# AD9920A

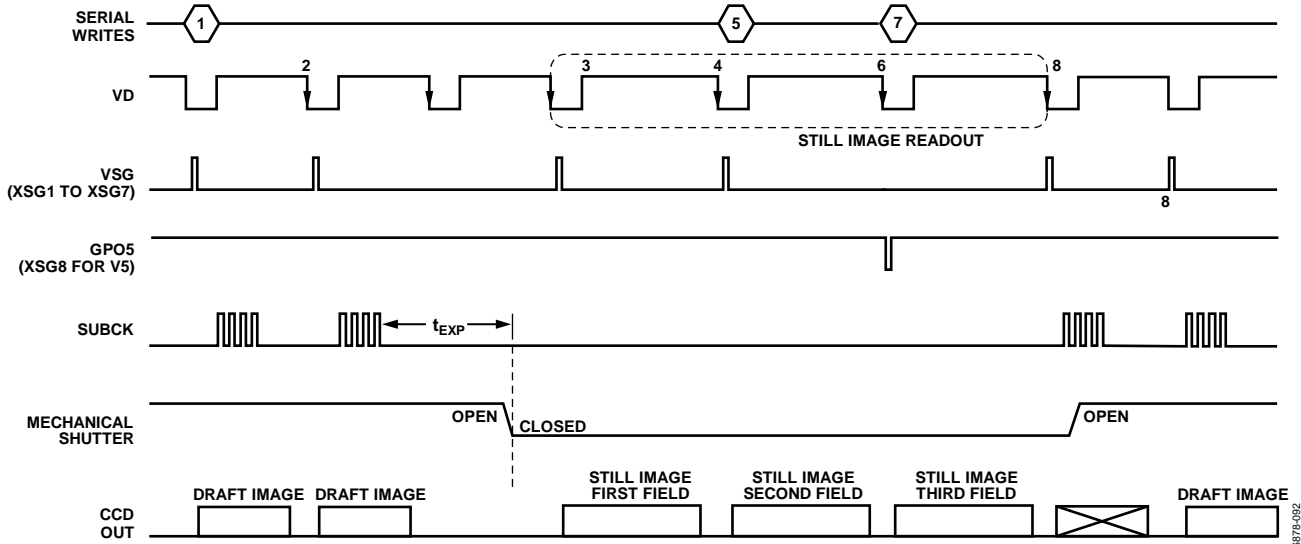

Figure 92. Using GPO5 Manual Trigger Mode for SG Signal

068778-092

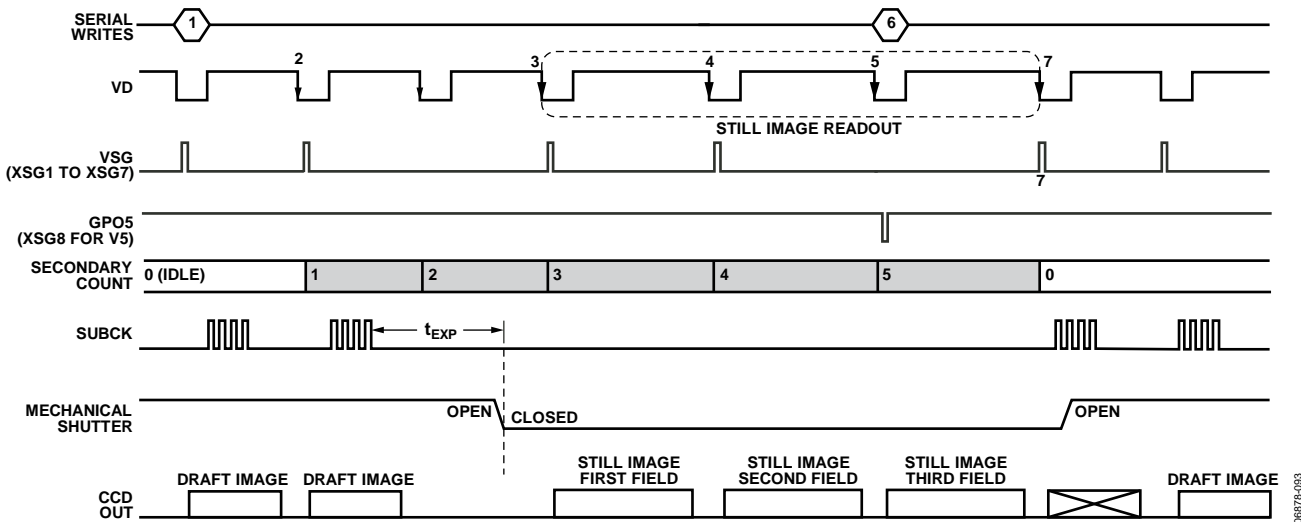

Figure 93. Using GPO5 with Secondary Counter to Control SG Signal

068778-093

## MANUAL SHUTTER OPERATION USING ENHANCED SYNC MODES

The AD9920A also supports an external signal to control exposure, using the SYNC input. Generally, the SYNC input is used as an asynchronous reset signal during master mode operation. When the enhanced SYNC mode is enabled, the SYNC input provides additional control of the exposure operation.

### Normal SYNC Mode (Mode 1)

By default, the SYNC input is used in master mode to synchronize the internal counters of the AD9920A with external timing. The horizontal, vertical, and field designator signals are reset by the rising edge of the SYNC pulse. Figure 94 shows how this mode operates, highlighting the behavior of the mode field designator.

### Enhanced SYNC Modes (Mode 2 and Mode 3)

The enhanced SYNC modes can be used to accommodate unique synchronization requirements during exposure operations. In SYNC Mode 2, the V and VSG outputs are suspended and the VD output is masked. The V-outputs are held at the dc value established by the V-Sequence 0 start polarities. There is no SCP operation, but the H-counter is still enabled. Finally, the AFE sampling clocks, HD, H/RG, CLPOB, and HBLK, are operational and use V-Sequence 0 behavior. See Figure 95 for more details.

To enable the enhanced SYNC modes, set the ENH\_SYNC\_EN register (Address 0x13, Bit 3) to 1.

SYNC Mode 3 uses all the features of Mode 2, but the V-outputs are continuous through the SYNC pulse interval. VD control pulses are masked during the SYNC interval, and the HD pulse can also be masked, if required (see Figure 96).

It is important to note that in both enhanced modes, the SYNC pulse resets the counters at both the falling edge and the rising edge of the SYNC pulse.

### Register Update and Field Designator

When using SYNC Mode 2 or SYNC Mode 3, VD-updated registers, such as PRIMARY\_ACTION, are not updated during the SYNC interval, and the SCP0 function is ignored and held at 0 (see Figure 97).

When using either SYNC Mode 2 or SYNC Mode 3, both the rising and falling edges increment the internal field designator; therefore, the new register data takes effect and VTP information is updated to new SEQ0 data. However, this does not occur if the mode register is creating an output of one field. In that case, the region, sequence, and group information does not change (see Figure 98).

### Shutter Operation in SLR Mode

The following steps are shown in Figure 99.

1. To turn on VSUB, write to the appropriate GP registers to trigger VSUB and start the manual exposure (PRIMARY\_ACTION = 5). This change takes effect after the next VD. SUBCK is suppressed during the exposure and readout phases.
2. To turn on MSHUT during the interval between the next VD and SYNC, write to the appropriate GP register. When MSHUT is in the on position, it has line and pixel control. This change takes effect on the SYNC falling edge because there is an internal VD.
3. If the mode register is programmed to cycle through multiple fields (5, 7, 3, 5, 7, 3, ..., in this example), the internal field designator increments. If the mode register is not required to increment, set up the mode register such that it outputs only one field. This prevents the mode counter from incrementing during the SYNC interval.
4. Write to the manual readout trigger to begin the manual readout (PRIMARY\_ACTION = 6). Write to the appropriate GP registers to trigger MSHUT to toggle low at the end of the exposure. This change takes effect on the SYNC rising edge during readout. Because VD register update is disabled, the trigger takes effect on the SYNC rising edge. The MSHUT falling edge is aligned with the SYNC rising edge. Because the MSHUT falling edge is aligned with VD, it may be necessary to insert a dummy VD to delay the readout.

Because the internal exposure counter (the primary counter) is not used during manual SYNC mode operation and the VD register update is disabled, control is lost on the fine placement of the GP signals for VSUB, MSHUT, and STROBE edges while SYNC is low.

### Serial Registers for Enhanced SYNC Modes

SYNC Mode 2 and SYNC Mode 3 are controlled using the registers listed in Table 47. These registers are located at Address 0x13, Bits[6:3].

**Table 47. Registers for Enhanced SYNC Modes**

Register	Length (Bits)	Description
ENH_SYNC_EN	1	High active to enable masking (default low)
SYNC_MASK_V	1	High active to enable masking (default high)
SYNC_MASK_VD	1	High active to enable masking (default high)
SYNC_MASK_HD	1	High active to enable masking (default low)

# AD9920A

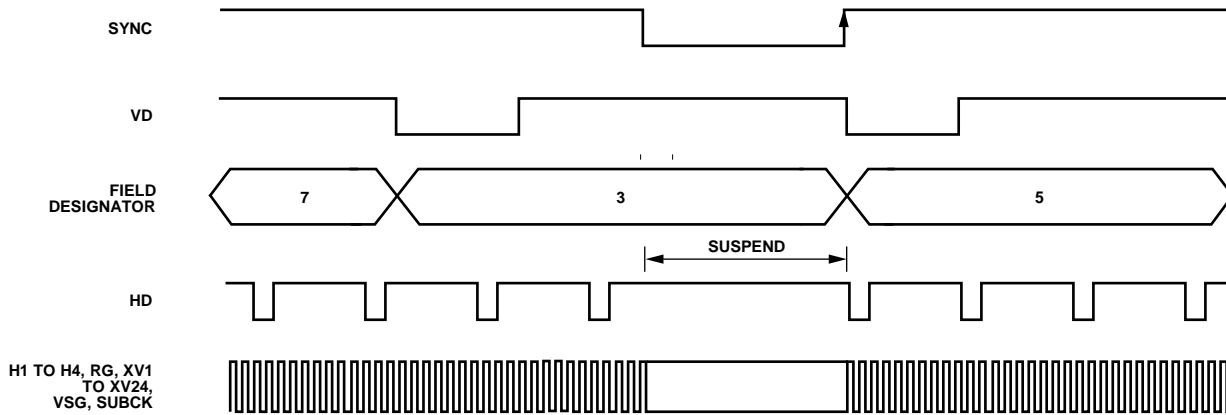

**NOTES**

1. THE SYNC RISING EDGE RESETS VD/HD AND COUNTERS TO 0.
2. SYNC POLARITY IS PROGRAMMABLE USING SYNCPOL REGISTER (ADDR 0x13).
3. DURING SYNC LOW, ALL INTERNAL COUNTERS ARE RESET AND VD/HD CAN BE SUSPENDED USING THE SYNCSPEND REGISTER (ADDR 0x13).
4. THE SYNC RISING EDGE CAUSES THE INTERNAL FIELD DESIGNATOR TO INCREMENT.
5. IF SYNCSPEND = 1, VERTICAL CLOCKS, H1 TO H4, AND RG ARE HELD AT THE SAME POLARITY SPECIFIED BY OUT\_CONTROL = LOW.
6. IF SYNCSPEND = 0, ALL CLOCK OUTPUTS CONTINUE TO OPERATE NORMALLY UNTIL THE SYNC RESET EDGE.

068778-034

Figure 94. Normal SYNC (Default Mode 1)

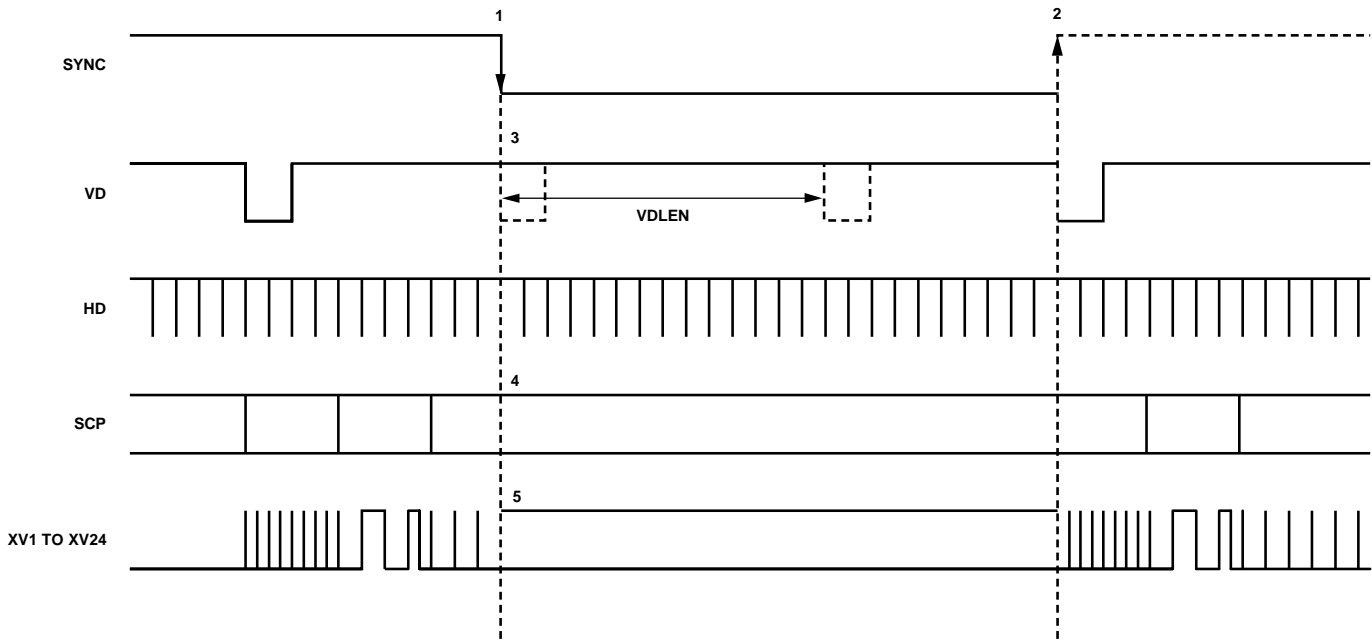

- 1 FALLING EDGE RESYNCS THE CIRCUIT TO THE LINE/PIXEL NUMBER 0. VD AND HD INTERNALLY RESYNC.
- 2 RISING EDGE RESETS COUNTERS.
- 3 VD IS DISABLED DURING SYNC. THE REGISTER IS PROGRAMMABLE.
- 4 SCP, HBLK, AND CLPOB ARE HELD AT SEQ0 VALUE.
- 5 XV1 TO XV24 SIGNALS ARE HELD AT THE V-OUTPUT START POLARITY.

Figure 95. Enhanced SYNC Mode 2 with Vertical Signals Held at VTP Start Value

068778-035

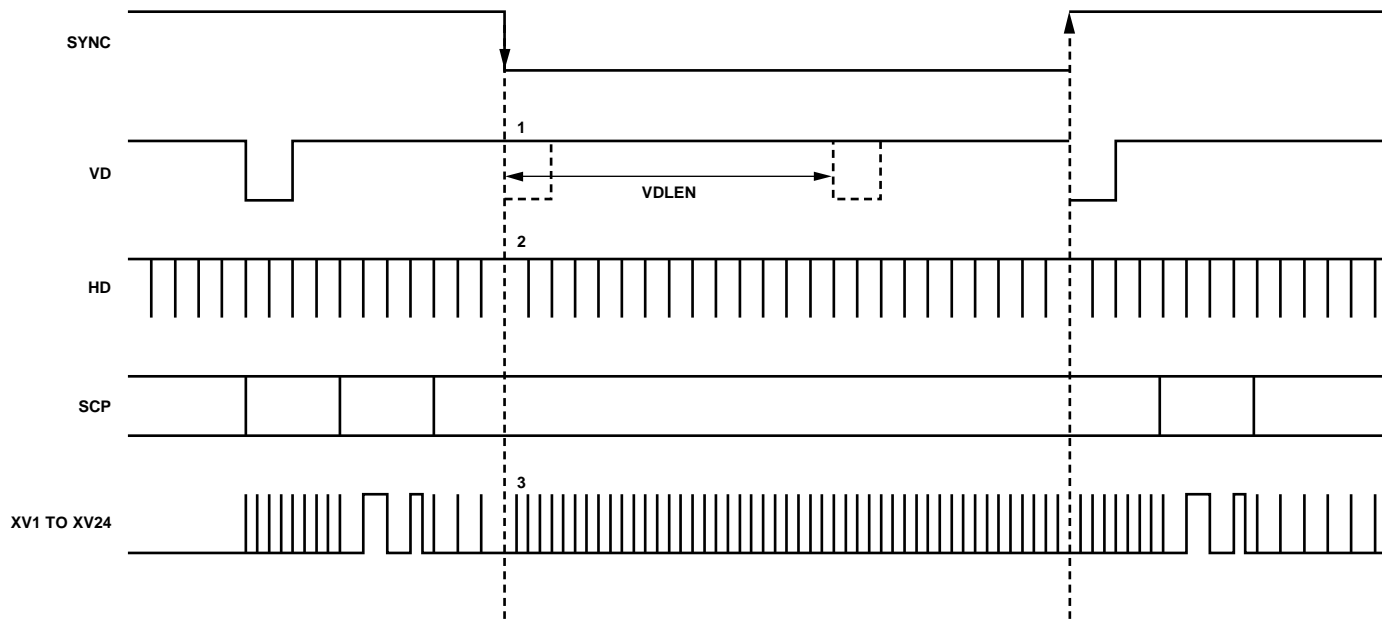

<sup>1</sup>SYNC\_MASK\_VD REGISTER ENABLES MASKING OF VD DURING SYNCSPEND WHEN SET HIGH (DEFAULT).  
<sup>2</sup>SYNC\_MASK\_HD REGISTER ENABLES MASKING OF HD DURING SYNCSPEND WHEN SET HIGH (DEFAULT).  
<sup>3</sup>V-OUTPUT PULSES CONTINUE IN SEQUENCE.

Figure 96. Enhanced SYNC Mode 3

06376-096

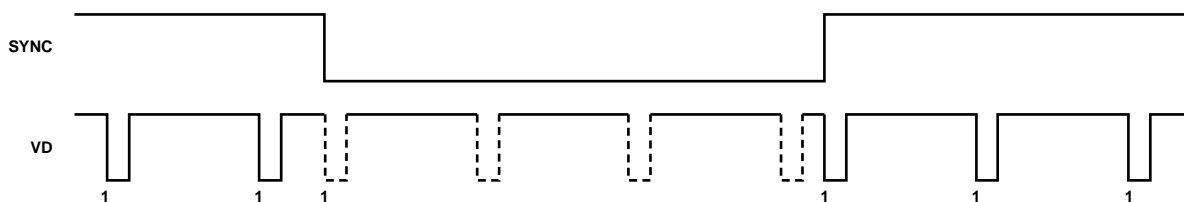

<sup>1</sup>VD REGISTERS ARE UPDATED HERE.

NOTES  
 1. VD-UPDATED REGISTERS (FOR EXAMPLE, PRIMARY\_ACTION) ARE DISABLED DURING THE SYNC INTERVAL.

Figure 97. Register Update Behavior

06376-097

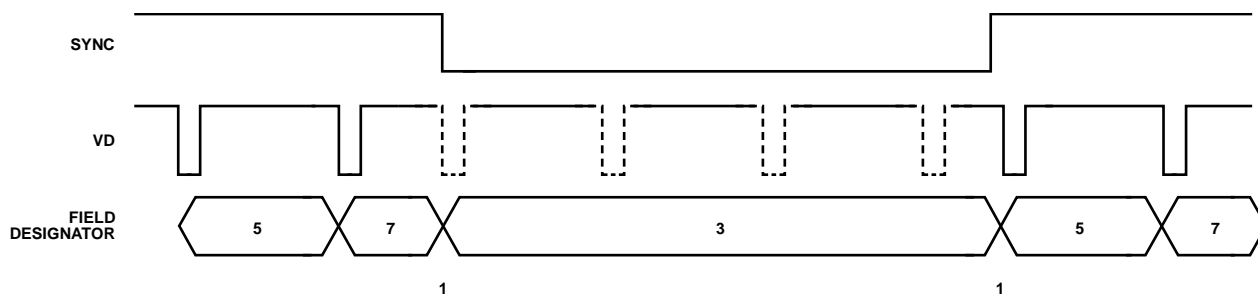

<sup>1</sup>FIELD DESIGNATOR IS INCREMENTED ON BOTH SYNC EDGES.

Figure 98. Enhanced SYNC Mode Effect on Field Designator

06376-098

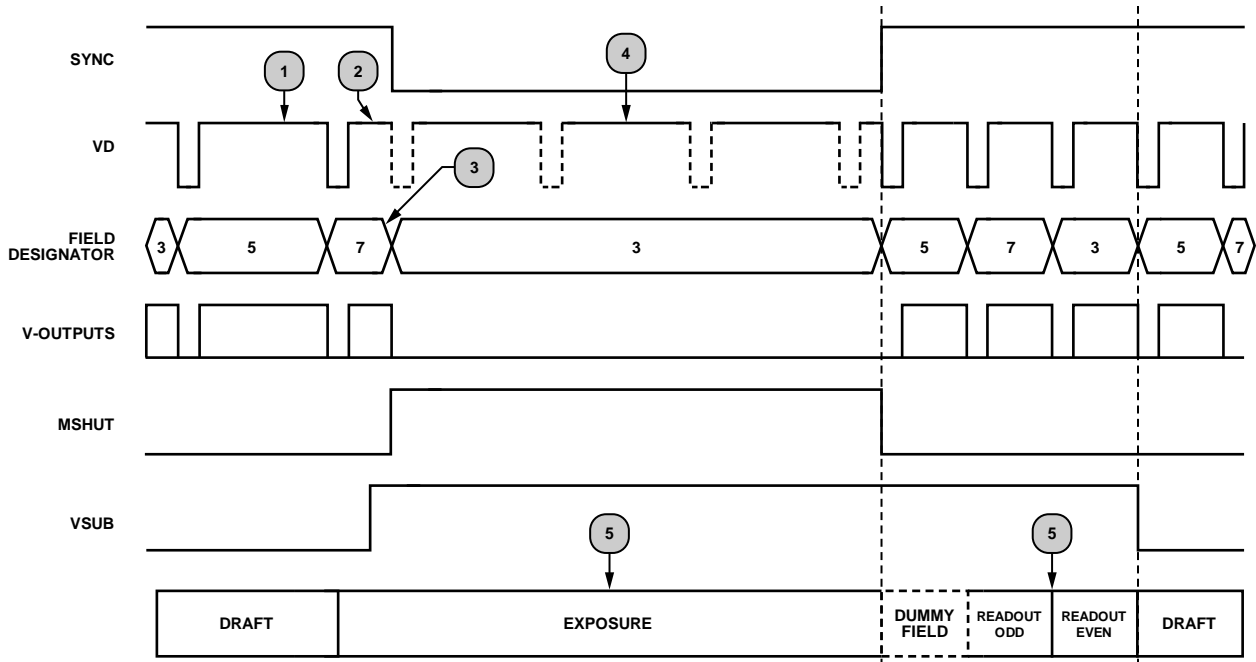

**SHUTTER OPERATION IN SLR MODE**

1REFER TO STEP 1.

2REFER TO STEP 2.

3REFER TO STEP 3.

4REFER TO STEP 4.

5SUBCK OUTPUT IS SUPPRESSED DURING EXPOSURE AND READOUT WHEN EXPOSURE TRIGGER IS USED.

Figure 99. Enhanced SYNC Mode—Manual Shutter Operation, SLR Mode

## ANALOG FRONT END DESCRIPTION AND OPERATION

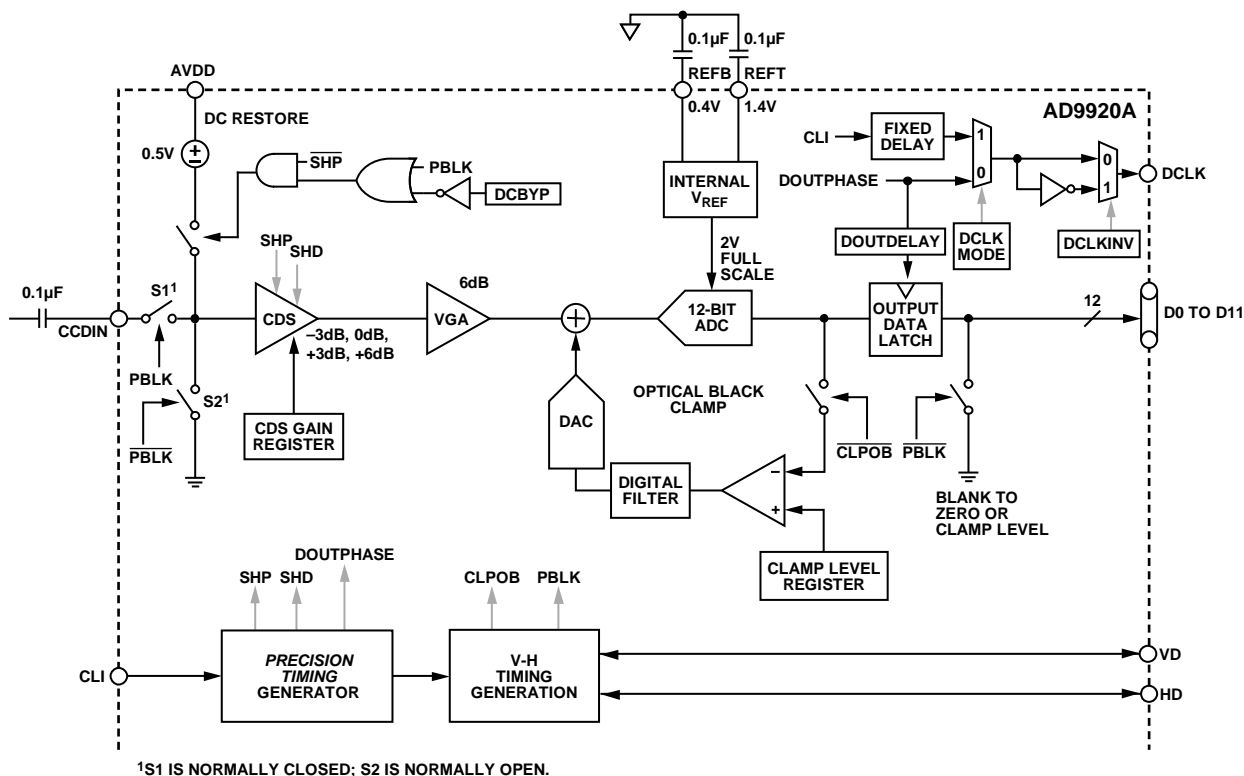

Figure 100. Analog Front End Functional Block Diagram

06876-100

The AD9920A signal processing chain is shown in Figure 100. Each processing step is essential for achieving a high quality image from the raw CCD pixel data.

### DC Restore

To reduce the large dc offset of the CCD output signal, a dc restore circuit is used with an external  $0.1\ \mu\text{F}$  series coupling capacitor. This restores the dc level of the CCD signal to approximately  $1.3\ \text{V}$  ( $\text{AVDD} - 0.5\ \text{V}$ ), making it compatible with the  $1.8\ \text{V}$  core supply voltage of the AD9920A. The dc restore switch is active during the SHP sample pulse time.

The dc restore circuit can be disabled when the optional PBLK signal is used to isolate large-signal swings from the CCD input (see the Analog Preblanking section). Bit 6 of AFE Register Address  $0x00$  controls whether the dc restore is active during the PBLK interval.

### Analog Preblanking (PBLK)

During certain CCD blanking or substrate clocking intervals, the CCD input signal to the AD9920A may increase in amplitude beyond the recommended input range. The PBLK signal can be used to isolate the CDS input from large-signal swings. While PBLK is active (low), the CDS input is internally shorted to ground. It is recommended that PBLK be used to protect the CDS input during the horizontal blanking and/or when the SUBCK output is toggled.

Note that because the CDS input is shorted during PBLK, the CLPOB pulse should not be used during the same active time as the PBLK pulse.

### Correlated Double Sampler (CDS)

The CDS circuit samples each CCD pixel twice to extract the video information and to reject low frequency noise. The timing shown in Figure 23 illustrates how the two internally generated CDS clocks, SHP and SHD, are used to sample the reference level and data level of the CCD signal, respectively. The placement of the SHP and SHD sampling edges is determined by the setting of the SHPLOC and SHDLOC registers located at Address  $0x38$ . Placement of these two clock signals is critical for achieving the best performance from the CCD.

The CDS gain is variable in four steps by using AFE Register Address  $0x04$ :  $-3\ \text{dB}$ ,  $0\ \text{dB}$ ,  $+3\ \text{dB}$ , and  $+6\ \text{dB}$ . Improved noise performance results from using the  $+3\ \text{dB}$  setting, but the input range is reduced (see the Analog Specifications section).

# AD9920A

## Variable Gain Amplifier (VGA)

The VGA stage provides a gain range of approximately 6 dB to 42 dB, programmable with 10-bit resolution through the serial digital interface. A gain of 6 dB is needed to match a 1 V input signal with the ADC full-scale range of 2 V. When compared with 1 V full-scale systems, the equivalent gain range is 0 dB to 36 dB.

The VGA gain curve follows a linear-in-dB characteristic. The exact VGA gain is calculated for any gain register value by

$$\text{Gain (dB)} = (0.0358 \times \text{Code}) + 5.76 \text{ dB}$$

where *Code* is the range of 0 to 1023.

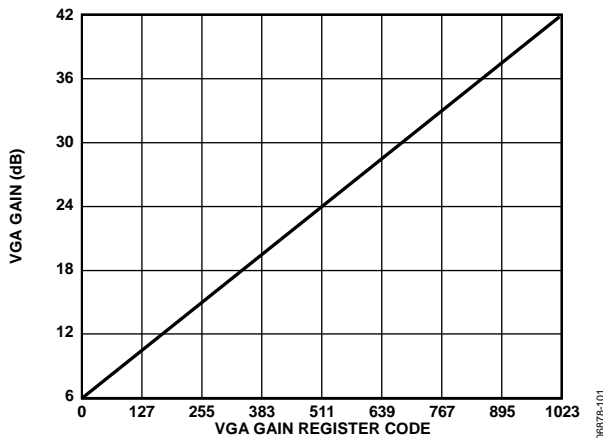

Figure 101. VGA Gain Curve

## Analog-to-Digital Converter (ADC)

The AD9920A uses a high performance ADC architecture optimized for high speed and low power. Differential non-linearity (DNL) performance is typically better than 0.5 LSB. The ADC uses a 2 V input range. See Figure 6, Figure 7, and Figure 8 for typical linearity and noise performance plots for the AD9920A.

## Optical Black Clamp

The optical black clamp loop is used to remove residual offsets in the signal chain and to track low frequency variations in the CCD black level. During the optical black (shielded) pixel interval on each line, the ADC output is compared with a fixed black level reference, which is selected by the user in the CLAMPLEVEL register. The value can be programmed from 0 LSB to 255 LSB in 1023 steps.

The resulting error signal is filtered to reduce noise, and the correction value is applied to the ADC input through a DAC. Normally, the optical black clamp loop is turned on once per horizontal line, but this loop can be updated more slowly to suit a particular application. If external digital clamping is used during the postprocessing, the AD9920A optical black clamping can be disabled using Bit 2 in AFE Register Address 0x00. When the loop is disabled, the CLAMPLEVEL register can still be used to provide fixed offset adjustment.

Note that if the CLPOB loop is disabled, higher VGA gain settings reduce the dynamic range because the uncorrected offset in the signal path is gained up.

The CLPOB pulse should be aligned with the CCD optical black pixels. It is recommended that the CLPOB pulse duration be at least 20 pixels wide. Shorter pulse widths can be used, but the ability of the loop to track low frequency variations in the black level is reduced. See the Horizontal Timing Sequence Example section for timing examples.

## Digital Data Outputs

The AD9920A digital output data is latched using the rising edge of the DOUTPHASE register value, as shown in Figure 100. Output data timing is shown in Figure 25 and Figure 26. It is also possible to leave the output latches transparent so that the data outputs are valid immediately from the ADC. Programming Bit 1 in AFE Register Address 0x01 to 1 sets the output latches to transparent. The data outputs can also be disabled (three-stated) by setting Bit 0 in AFE Register Address 0x01 to 1.

The DCLK output can be used for external latching of the data outputs. By default, the DCLK output tracks the values of the DOUTPHASE registers. By setting the DCLKMODE register, the DCLK output can be held at a fixed phase, and the DOUTPHASE register values are ignored. The DCLK output can also be inverted with respect to the data output, using the DCLKINV register bit.

The switching of the data outputs can couple noise back into the analog signal path. To minimize switching noise, it is recommended that the DOUTPHASE registers be set to the same edge as the SHP sampling location or up to 15 edges after the SHP sampling location. Other settings can produce good results, but experimentation is necessary. It is recommended that the DOUTPHASE location not occur between the SHD sampling location and 15 edges after the SHD location. For example, if SHDLOC = 0, DOUTPHASE should be set to an edge location of 16 or greater. If adjustable phase is not required for the data outputs, the output latch can be left transparent using Bit 1 in AFE Register Address 0x01.

The data output coding is normally straight binary, but the coding can be changed to gray coding by setting Bit 2 in AFE Register Address 0x01 to 1.

## APPLICATIONS INFORMATION

### POWER-UP SEQUENCE FOR MASTER MODE

When the AD9920A is powered up, the following sequence is recommended (refer to Figure 102 for each step). Note that a SYNC signal is required for master mode operation. If an external SYNC pulse is not available, it is possible to generate an internal SYNC event by writing to the SWSYNC register.

1. Turn on the 3 V and 1.8 V power supplies for the AD9920A and start master clock CLI.
2. The SYNC/RST pin is configured as the RST pin by default. It must be brought high before any register writes are performed. Configure the SYNC/RST pin for SYNC functionality by writing Register 0x12 = 0x00, and then perform a software reset by writing Register 0x10 to 0x01.
3. Make sure that VDR\_EN is low. If driving VDR\_EN with a GPO, set the appropriate bit in the GPO\_OUTPUT\_EN register (Address 0x7A, Bits[23:16]) to 1 to configure it as an output and make sure that the appropriate bit in the GP\_STBY3 register (Address 0x27, Bits[15:8]) is set to 0.
4. Power up the V-driver supplies.
5. Define the standby status of the AD9920A vertical outputs. Write to the Standby2 and Standby3 polarity registers (Address 0x25 and Address 0x26 = 0x1FF8000). Write 0xFF8000 to Address 0x1C to configure the XV and VSG signals. Write 0x100000 to Register 0xD1. When using 3-phase HCLK mode, enable this mode before Step 6 by setting Address 0x24 = 0x10.
6. Place the AFE into normal operation and enable clamping (Address 0x00 = 0x04). If using CLO to drive a crystal, set OSC\_RST = 1. Wait at least 500  $\mu$ s before performing Step 8.
7. Load the required registers to configure vertical timing, horizontal timing, high speed timing, and shutter timing.
8. Reset the internal timing core (TGCORE\_RST). If a 2 $\times$  clock is used for CLI, the CLIDIVIDE register (Address 0x0D) should be set to 1 before TGCORE\_RST is written (Address 0x14 = 0x01). Wait at least 100  $\mu$ s before performing Step 9.
9. Bring the VDR\_EN pin high. If driving VDR\_EN with a GPO, write to the appropriate GPO polarity bit in Address 0x7A to set the VDR\_EN signal high (updated at the next VD). Note that IOVDD must be at the same voltage as VDVDD if GPO is used for VDR\_EN.
10. Enable the AD9920A outputs (OUT\_CONTROL register, Address 0x11 = 0x01). OUT\_CONTROL is a VD-updated register; therefore, the outputs become active after the next VD falling edge.
11. Enable master mode operation by setting Register 0x20 = 0x01.
12. Generate a SYNC event. SYNC should be high at power-up. Bring the SYNC input low for a minimum of 100 ns, and then bring SYNC high again. This resets the internal counters and starts VD/HD operation. The first VD/HD edge allows VD-updated register updates (including updates of OUT\_CONTROL) to occur, enabling all outputs. If a hardware SYNC is not available, the SWSYNC register (Address 0x13, Bit 24) can be used to initiate a SYNC event.

Note that VDR\_EN must remain high to achieve proper vertical outputs during normal operation.

# AD9920A

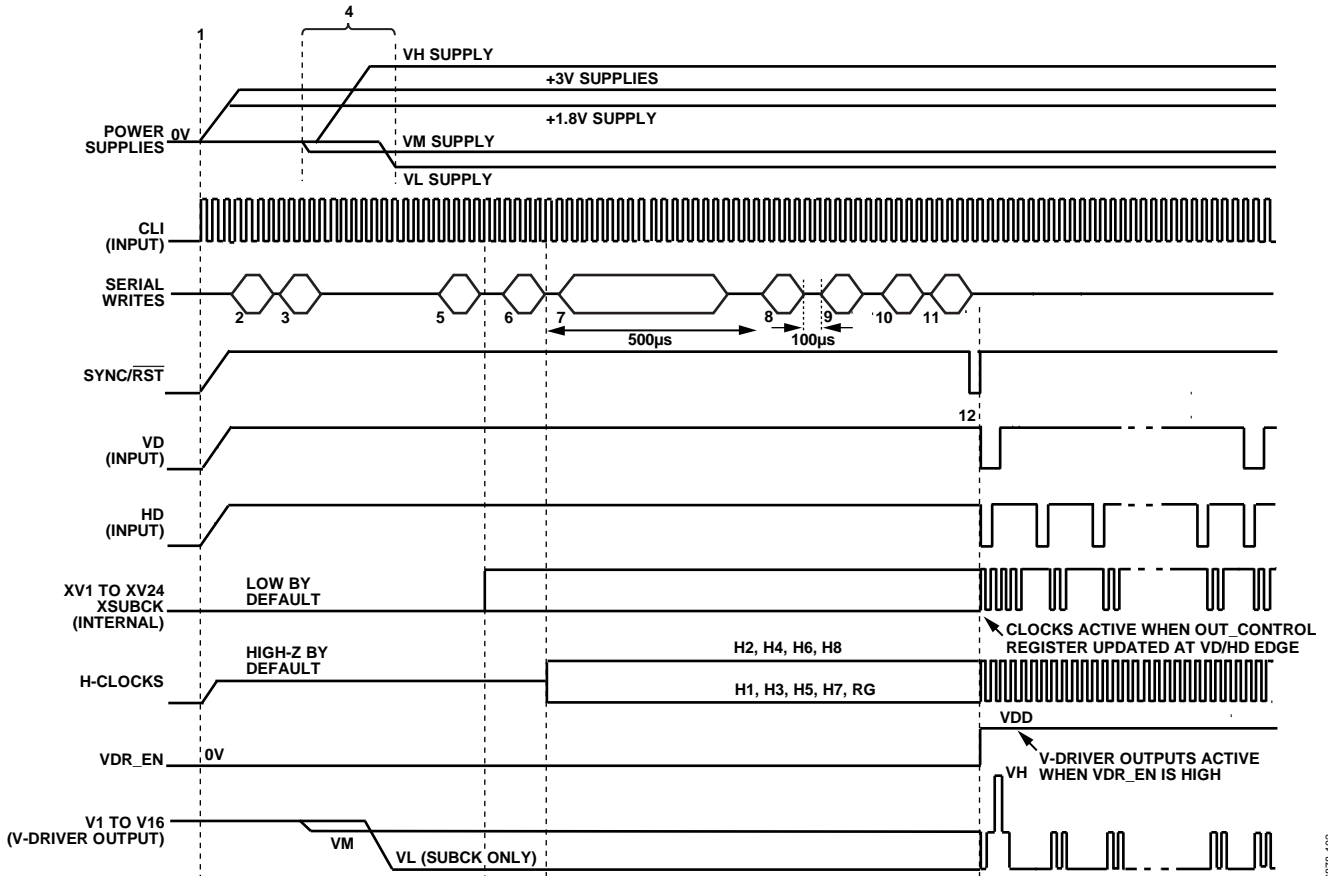

Figure 102. Recommended Power-Up Sequence and Synchronization, Master Mode

06878-102

## POWER-UP SEQUENCE FOR SLAVE MODE

When the AD9920A is used in slave mode, the VD/HD inputs are used to synchronize the internal counters. For more detail on the counter reset operation, see Figure 103.

1. Turn on the 3 V and 1.8 V power supplies for the AD9920A, and start master clock CLI.
2. Reset the internal AD9920A registers. If the SYNC/RST pin is functioning as RST, apply a rising edge to the SYNC/RST pin. If the SYNC/RST pin is functioning as SYNC, tie this pin high. Then perform a software reset by writing Register 0x10 to 0x01.
3. Make sure that VDR\_EN is low. If driving VDR\_EN with a GPO, set the appropriate bit in the GPO\_OUTPUT\_EN register (Address 0x7A, Bits[23:16]) to 1 to configure it as an output and make sure that the appropriate bit in the GP\_STBY3 register (Address 0x27, Bits[15:8]) is set to 0.
4. Power up the V-driver supplies.
5. Define the standby status of the AD9920A vertical outputs. Write to the Standby2 and Standby3 polarity registers (Address 0x25 and Address 0x26 = 0x1FF8000). Write 0xFF8000 to Address 0x1C to configure the XV and VSG signals. Write 0x100000 to Register 0xD1. When using 3-phase HCLK mode, enable this mode before Step 6 by setting Address 0x24 = 0x10.
6. Place the AFE into normal operation and enable clamping (Address 0x00 = 0x04). If using CLO to drive a crystal, set OSC\_RST = 1. Wait at least 500  $\mu$ s before performing Step 8.
7. Load the required registers to configure vertical timing, horizontal timing, high speed timing, and shutter timing.
8. Reset the internal timing core (TG\_CORE\_RST). If a 2 $\times$  clock is used for CLI, the CLIDIVIDE register (Address 0x0D) should be set to 1 before TG\_CORE\_RST is written (Address 0x14 = 0x01). Wait at least 100  $\mu$ s before performing Step 9.
9. Bring the VDR\_EN pin high. If driving VDR\_EN with a GPO, write to the appropriate GPO polarity bit (Address 0x7A) to set the VDR\_EN signal high (updated at the next VD). Note that IOVDD must be at the same voltage as VDVDD if GPO is used for VDR\_EN.
10. Enable the AD9920A outputs (OUT\_CONTROL register, Address 0x11 = 0x01). OUT\_CONTROL is a VD-updated register; therefore, the outputs become active after the next VD falling edge.
11. Enable slave mode operation by setting Register 0x0E = 0x100.
12. Start VD and HD timing to synchronize the internal counters and begin operation. VD-updated registers are updated at the first VD falling edge.

Note that VDR\_EN must remain high to achieve proper vertical outputs during normal operation.

# AD9920A

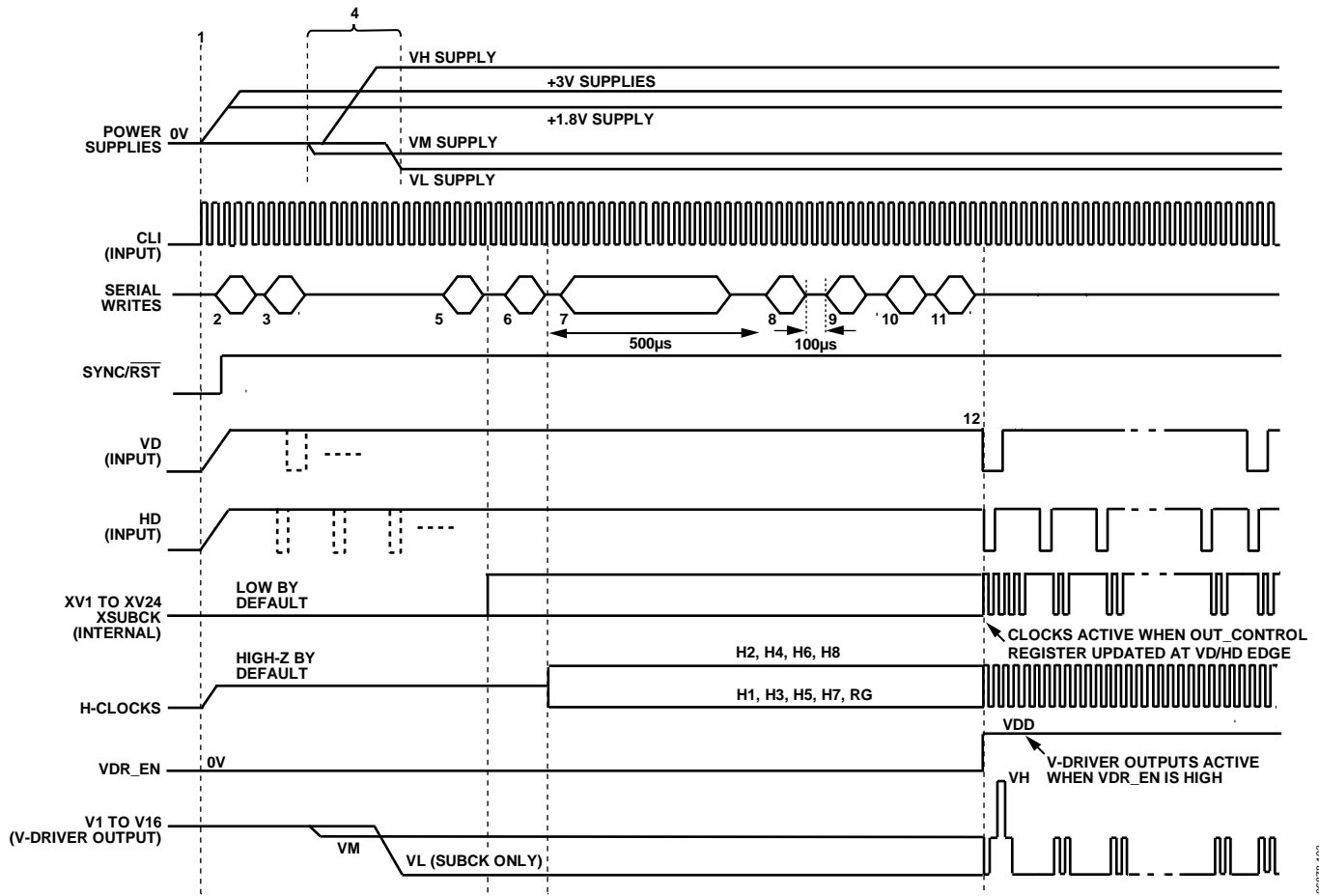

Figure 103. Recommended Power-Up Sequence and Synchronization, Slave Mode

06875-103

**POWER-DOWN SEQUENCE FOR MASTER AND SLAVE MODES**

1. Write 0 to the appropriate bit in the GPO\_OUTPUT\_EN register (Address 0x7A) to set the appropriate VDR\_EN control signal low.
2. The next VD edge updates Address 0x7A, causing the VDR\_EN signal to go low and disabling the V-driver outputs. If operating in slave mode, turn off VD and HD after VDR\_EN switches low.

3. Write 0x03 to the AFE standby register (Address 0x00) to place the AD9920A into Standby3 mode.
4. Power down the V-driver supplies.
5. Power down the 3 V and 1.8 V supplies.

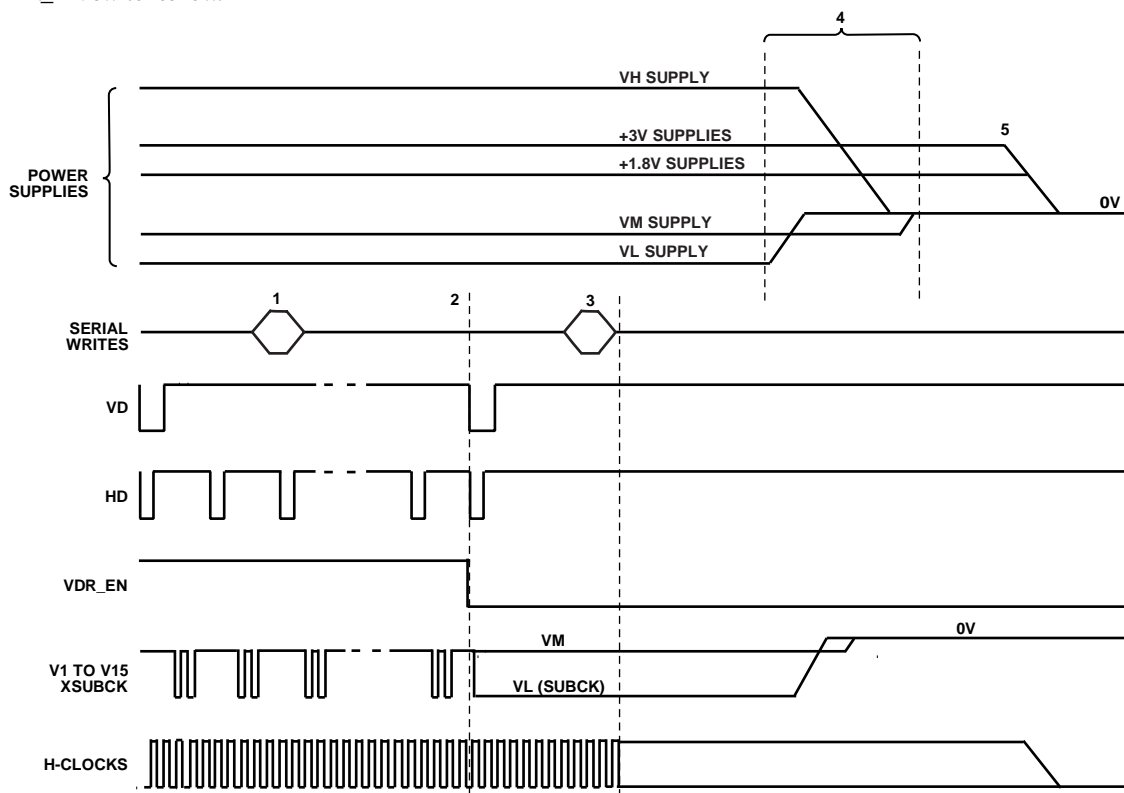

Figure 104. Recommended Power-Down Sequence, Master or Slave Mode

06578-104

## ADDITIONAL RESTRICTIONS IN SLAVE MODE

When operating in slave mode, note the following restrictions:

- The HD falling edge should be located in the same CLI clock cycle as the VD falling edge or later than the VD falling edge. The HD falling edge should not be located within one cycle prior to the VD falling edge.
- If possible, all start-up serial writes should be performed with VD and HD disabled. This prevents unknown behavior caused by partial updating of registers before all information is loaded. See the Power-Up Sequence for Master Mode section.
- There is an inhibit area for SHPLOC to meet the timing requirement  $t_{CLISHP}$  (see Figure 105, Figure 23, and Figure 24). This restriction is necessary to guarantee a stable reset of the H-counter in slave mode.
- When operating the part in slave mode and using a crystal oscillator to generate CLI, it can be very difficult to meet the  $t_{HDCLI}$  specification because there is no phase control over the oscillator output. Special care must be taken to meet the critical  $t_{HDCLI}$  specification when operating in this condition.

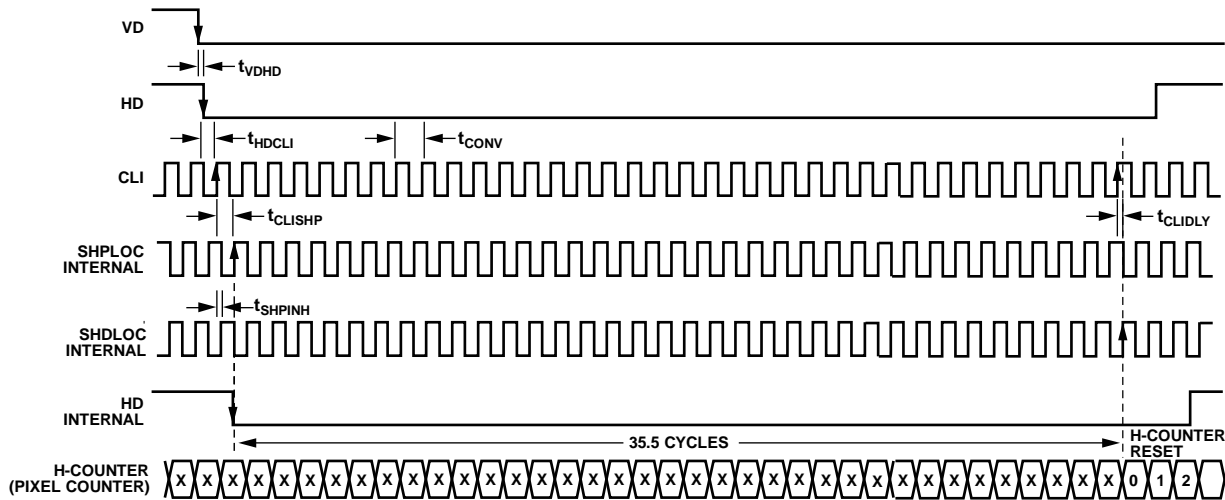

**NOTES:**

1. EXTERNAL HD FALLING EDGE IS LATCHED BY CLI RISING EDGE, AND THEN LATCHED BY SHPLOC (INTERNAL SAMPLING EDGE).
2. INTERNAL H-COUNTER IS ALWAYS RESET 35.5 CLOCK CYCLES AFTER THE INTERNAL HD FALLING EDGE AT SHDLOC (INTERNAL SAMPLING EDGE).
3. DEPENDING ON THE VALUE OF SHPLOC, H-COUNTER RESET CAN OCCUR 36 OR 37 CLI CLOCK EDGES AFTER THE EXTERNAL HD FALLING EDGE.
4. SHPLOC = 32, SHDLOC = 0 IS SHOWN. IN THIS CASE, THE H-COUNTER RESET OCCURS 36 CLI RISING EDGES AFTER HD FALLING EDGE.
5. HD FALLING EDGE SHOULD OCCUR COINCIDENT WITH THE VD FALLING EDGE (WITHIN SAME CLI CYCLE) OR AFTER THE VD FALLING EDGE. HD FALLING EDGE SHOULD NOT OCCUR WITHIN ONE CYCLE IMMEDIATELY BEFORE THE VD FALLING EDGE.

Figure 105. External VD/HD and Internal H-Counter Synchronization, Slave Mode

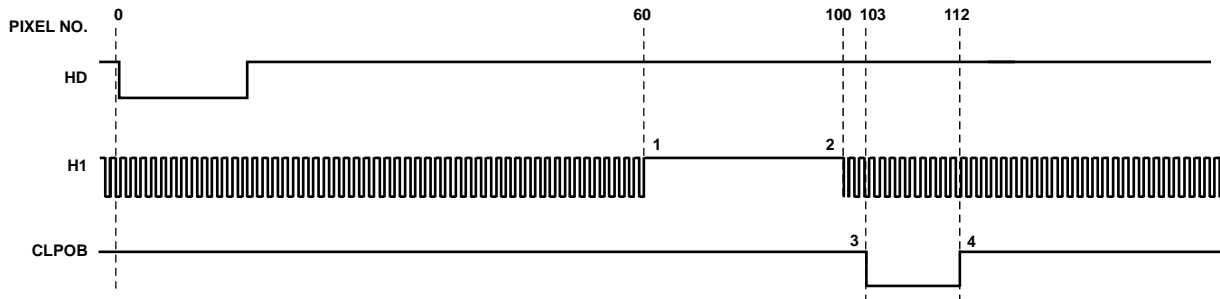

	MASTER MODE	SLAVE MODE
1HBLKTOG1	60	(60 - 36) = 24
2HBLKTOG2	100	(100 - 36) = 64
3CLPOBTOG1	103	(103 - 36) = 67
4CLPOBTOG2	112	(112 - 36) = 76

Figure 106. Example of Slave Mode Register Settings to Obtain Desired Toggle Positions

### VERTICAL TOGGLE POSITION PLACEMENT NEAR COUNTER RESET

An additional consideration during the reset of the internal counters is the vertical toggle position placement. There is a region of 36 pixels prior to the internal counter reset in which no toggles can take place.

Figure 107 shows this restriction for slave mode. The last 36 pixels before the counters are reset cannot be used. In slave mode, the counter reset is delayed with respect to VD/HD placement, so the inhibited area is different than it is in master mode.

It is recommended that Pixel Location 0 not be used for any of the toggle positions for the VSG and SUBCK pulses.

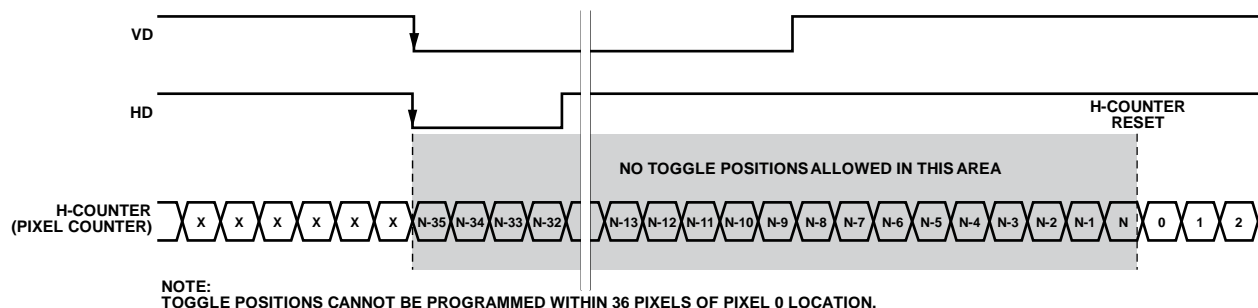

Figure 107. Toggle Position Inhibited Area, Slave Mode

06876-107

## STANDBY MODE OPERATION

The AD9920A contains three standby modes to optimize the overall power dissipation in a particular application. Bits[1:0] of Address 0x00 control the power-down state of the device.

**Table 48. Power States Set by Standby Register**

Standby Register, Bits[1:0]	Description
00	Normal operation (full power)
01	Standby1 mode
10	Standby2 mode
11	Standby3 mode (lowest power)

Table 49 and Table 50 summarize the operation of each power-down mode. The OUT\_CONTROL register takes priority over the Standby1 and Standby2 modes in determining the digital output states, but Standby3 mode takes priority over OUT\_CONTROL. Standby3 has the lowest power consumption and even shuts down the crystal oscillator circuit between CLI and CLO. Therefore, if CLI and CLO are being used with a crystal to generate the master clock, this circuit is powered down, and there is no clock signal.

**Table 49. Standby Mode Operation for HCLKMODE = 0x1, 0x2, or 0x4 (Standby Polarities for XV, XSUBCK, and GPO Outputs Are Programmable)**

I/O Block	Standby3 (Default) <sup>1, 2</sup>	OUT_CONTROL = Low <sup>2</sup>	Standby2 <sup>3, 4</sup>	Standby1 <sup>3, 4</sup>
AFE	Off	No change	Off	Only REFT, REFB on
Timing Core	Off	No change	Off	On
CLO Oscillator	Off	No change	Off	On
CLO	Low	No change	Low	Running
H1	High-Z	Low	Low (4.3 mA)	Low (4.3 mA)
H2	High-Z	High	High (4.3 mA)	High (4.3 mA)
H3	High-Z	Low	Low (4.3 mA)	Low (4.3 mA)
H4	High-Z	High	High (4.3 mA)	High (4.3 mA)
H5	High-Z	Low	Low (4.3 mA)	Low (4.3 mA)
H6	High-Z	High	High (4.3 mA)	High (4.3 mA)
H7	High-Z	Low	Low (4.3 mA)	Low (4.3 mA)
H8	High-Z	High	High (4.3 mA)	High (4.3 mA)
HL	High-Z	Low	Low (4.3 mA)	Low (4.3 mA)
RG	High-Z	Low	Low (4.3 mA)	Low (4.3 mA)
VD	Low	VDHDPOL value	VDHDPOL value	Running
HD	Low	VDHDPOL value	VDHDPOL value	Running
DCLK	Low	Running	Low	Running
D0 to D11	Low	Low	Low	Low
XV1 to XV24	Low	Low	Low	Low
XSUBCK	Low	Low	Low	Low
GPO1 to GPO4, GPO7, and GPO8	Low	Low	Low	Low

<sup>1</sup> To exit Standby3 or Standby2 mode, write 00 to the standby register (Address 0x00, Bits[1:0]) and then reset the timing core after 500 μs to guarantee proper settling of the oscillator and external crystal.

<sup>2</sup> Standby3 mode takes priority over OUT\_CONTROL for determining the output polarities.

<sup>3</sup> These polarities assume OUT\_CONTROL = high because OUT\_CONTROL = low takes priority over Standby1 and Standby2.

<sup>4</sup> Standby1 and Standby2 set H and RG drive strength to minimum value (4.3 mA).

When returning from Standby3 mode to normal operation, the timing core must be reset at least 500 μs after the STANDBY register is written to. This allows sufficient time for the crystal circuit to settle.

The vertical outputs can also be programmed to hold a specific value during the Standby3 mode by using Address 0x26. This register is useful during power-up if different polarities are required by the V-driver and CCD to prevent damage when VH and VL areas are applied. The polarities for Standby1 mode and Standby2 mode are also programmable, using Address 0x25, and OUT\_CONTROL = low uses the same polarities programmed for Standby1 and Standby2 modes in Address 0x25. The GPO polarities are programmable using Address 0x27.

Note that the GPO outputs are high-Z by default at power-up until Address 0x7A is used to select them as outputs.

## CLI FREQUENCY CHANGE

If the input clock CLI is interrupted or changed to a different frequency, the timing core must be reset for proper operation. After the CLI clock has settled to the new frequency, or the previous frequency is resumed, write 0 and then 1 to the TGCORE\_RST register (Address 0x14). This guarantees that the timing core operates properly.

**Table 50. Standby Mode Operation for HCLKMODE = 0x10  
(Standby Polarities for XV, XSUBCK, and GPO Outputs Are Programmable)**

I/O Block	Standby3 (Default) <sup>1, 2</sup>	OUT_CONTROL = Low <sup>2</sup>	Standby2 <sup>3, 4</sup>	Standby1 <sup>3, 4</sup>
AFE	Off	No change	Off	Only REFT, REFB on
Timing Core	Off	No change	Off	On
CLO Oscillator	Off	No change	Off	On
CLO	Low	No change	Low	Running
H1	High-Z	Low	Low (4.3 mA)	Low (4.3 mA)
H2	High-Z	Low	Low (4.3 mA)	Low (4.3 mA)
H3	High-Z	Low	Low (4.3 mA)	Low (4.3 mA)
H4	High-Z	Low	Low (4.3 mA)	Low (4.3 mA)
H5	High-Z	Low	Low (4.3 mA)	Low (4.3 mA)
H6	High-Z	Low	Low (4.3 mA)	Low (4.3 mA)
H7	High-Z	Low	Low (4.3 mA)	Low (4.3 mA)
H8	High-Z	Low	Low (4.3 mA)	Low (4.3 mA)
HL	High-Z	Low	Low (4.3 mA)	Low (4.3 mA)
RG	High-Z	Low	Low (4.3 mA)	Low (4.3 mA)
VD	Low	$\overline{\text{VDHDPOL}}$ value	$\overline{\text{VDHDPOL}}$ value	Running
HD	Low	$\overline{\text{VDHDPOL}}$ value	$\overline{\text{VDHDPOL}}$ value	Running
DCLK	Low	Running	Low	Running
D0 to D11	Low	Low	Low	Low
XV1 to XV24	Low	Low	Low	Low
XSUBCK	Low	Low	Low	Low
GPO1 to GPO4, GPO7, and GPO8	Low	Low	Low	Low

<sup>1</sup> To exit Standby3 or Standby2 mode, write 00 to the standby register (Address 0x00, Bits[1:0]) and then reset the timing core after 500  $\mu$ s to guarantee proper settling of the oscillator and external crystal.

<sup>2</sup> Standby3 mode takes priority over OUT\_CONTROL for determining the output polarities.

<sup>3</sup> These polarities assume OUT\_CONTROL = high because OUT\_CONTROL = low takes priority over Standby1 and Standby2.

<sup>4</sup> Standby1 and Standby2 set H and RG drive strength to minimum value (4.3 mA).

## CIRCUIT LAYOUT INFORMATION

The PCB layout is critical in achieving good image quality from the AD9920A. All of the supply pins, particularly the AVDD, TCVD, RGVDD, and HVDD pins, must be decoupled to ground with good quality, high frequency chip capacitors. The decoupling capacitors should be located as close as possible to the supply pins and should have a very low impedance path to a continuous ground plane. If possible, there should be a 4.7  $\mu\text{F}$  or larger value bypass capacitor for each main supply—AVDD, HVDD, and DRVDD—although this is not necessary for each individual pin. In most applications, the supply for RGVDD and HVDD is shared, which can be done as long as the individual supply pins are separately bypassed with 0.1  $\mu\text{F}$  capacitors. A separate 3 V supply can also be used for DRVDD, but this supply pin should still be decoupled to the same ground plane as the rest of the chip. A separate ground for DRVSS is not recommended.

The analog bypass pins (REFT and REFB) should be carefully decoupled to ground as close as possible to their respective pins. The analog input (CCDIN) capacitor should be located close to the pin.

The H1 to H8, HL, and RG traces should be designed to have low inductance to minimize distortion of the signals. The complementary signals, H1/H3/H5/H7 and H2/H4/H6/H8, should be routed as close together and as symmetrically as possible to minimize mutual inductance. Heavier PCB traces are recommended because of the large transient current demand on H1 to H8 by the CCD. If possible, physically locating the AD9920A closer to the CCD reduces the inductance on these lines. The routing path should be as direct as possible from the AD9920A to the CCD.

Note that it is recommended that all H1 to H8 outputs on the AD9920A be used together for maximum flexibility in drive strength settings. A typical CCD with H1 and H2 inputs should have only the AD9920A H1, H3, H5, and H7 outputs connected together to drive CCD H1, and only the AD9920A H2, H4, H6, and H8 outputs connected together to drive CCD H2.

Similarly, a CCD with H1, H2, H3, and H4 inputs should have the following:

- H1 and H3 connected to CCD H1
- H2 and H4 connected to CCD H2
- H5 and H7 connected to CCD H3
- H6 and H8 connected to CCD H4

### TYPICAL 3 V SYSTEM

The AD9920A typical circuit connections for a 3 V system are shown in Figure 110 and Figure 112. This application uses an external 3.3 V supply, which is connected to the LDO input of the AD9920A. The LDO provides 1.8 V to the AVDD, TCVD, and DVDD pins.

### EXTERNAL CRYSTAL APPLICATION

The AD9920A contains an on-chip oscillator for driving an external crystal. Figure 108 shows an example application using a typical 27 MHz crystal. There is an internal feedback resistor (typical value  $\approx 7 \text{ M}\Omega$ ). However, in the event that the internal resistance is too high and prevents proper crystal operation, an external resistor can be added in parallel. The value of this external resistor is typically between 1  $\text{M}\Omega$  and 2  $\text{M}\Omega$ . For the exact value of this resistor and other necessary external resistors and capacitors, it is best to consult the crystal manufacturer.

Note that a 2 $\times$  crystal is not recommended for use with the CLO oscillator circuit. The crystal frequency should not exceed 40.5 MHz.

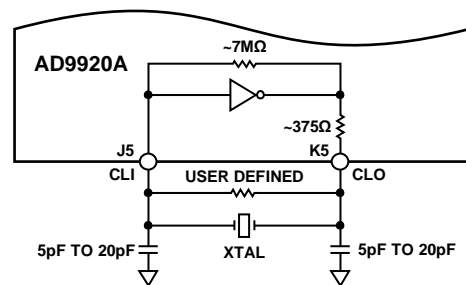
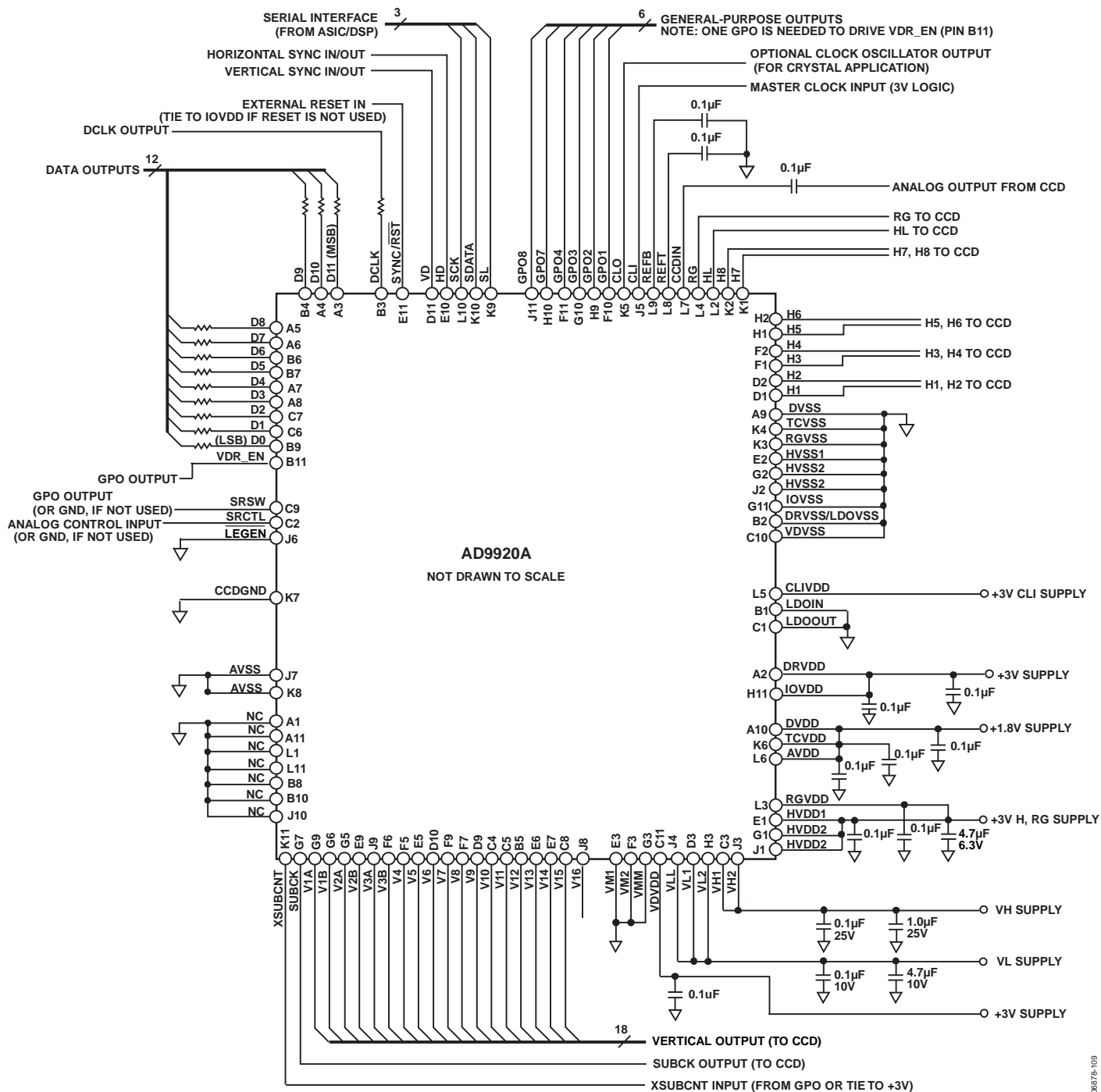

Figure 108. Crystal Application Using CLI/CLO

08879-1.08

## CIRCUIT CONFIGURATIONS



06878-109

# AD9920A

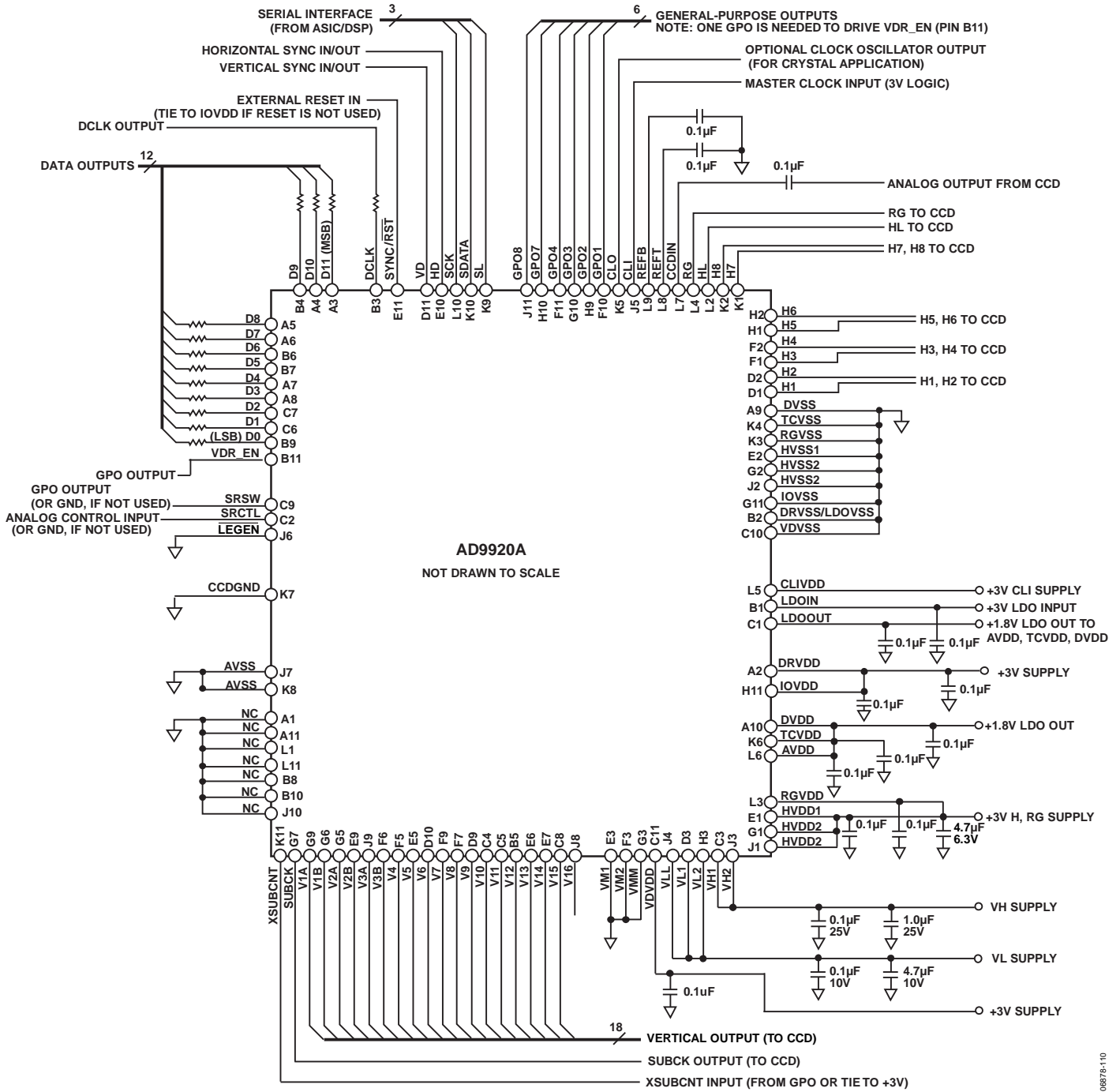

Figure 110. Typical 3 V Circuit Configuration in Legacy Mode (18-Channel Mode)

06878-110

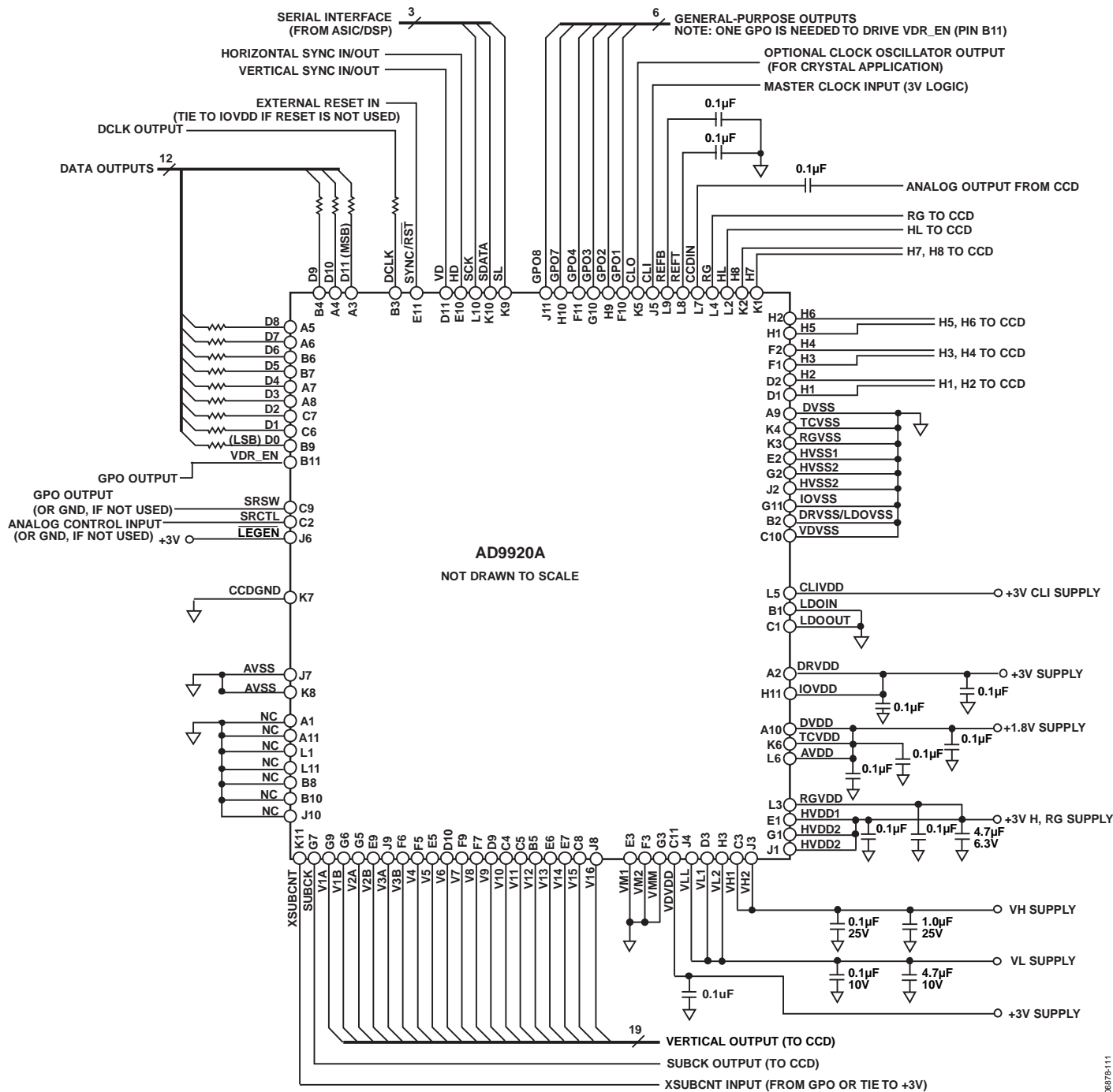
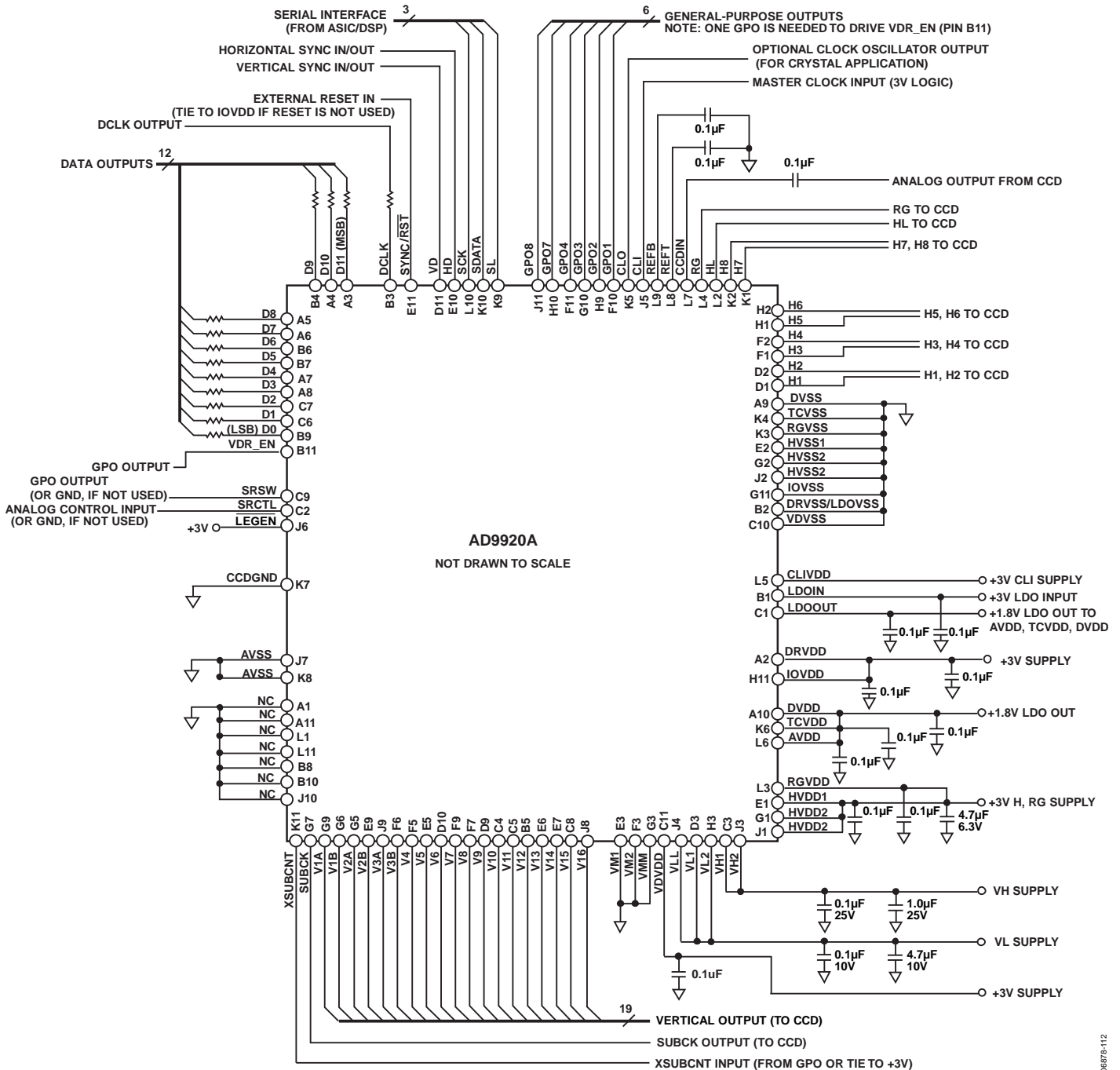

Figure 111. Typical 1.8 V Circuit Configuration in 19-Channel Mode

06978-111

# AD9920A



08878-112

## SERIAL INTERFACE

### SERIAL INTERFACE TIMING

The internal registers of the AD9920A are accessed through a 3-wire serial interface. Each register consists of a 12-bit address and a 28-bit data-word. Both the 12-bit address and 28-bit data-word are written starting with the LSB. To write to each register, a 40-bit operation is required, as shown in Figure 113. Although many registers are fewer than 28 bits wide, all 28 bits must be written for each register. For example, if the register is only 20 bits wide, the upper eight bits are don't care bits and must be filled with 0s during the serial write operation. If fewer than 28 data bits are written, the register is not updated with new data.

Figure 114 shows a more efficient way to write to the registers, using the AD9920A address auto-increment capability. Using this method, the lowest desired address is written first, followed by multiple 28-bit data-words. Each new 28-bit data-word is automatically written to the next highest register address. By eliminating the need to write each 12-bit address, faster register loading is achieved. Continuous write operations can be used starting with any register location.

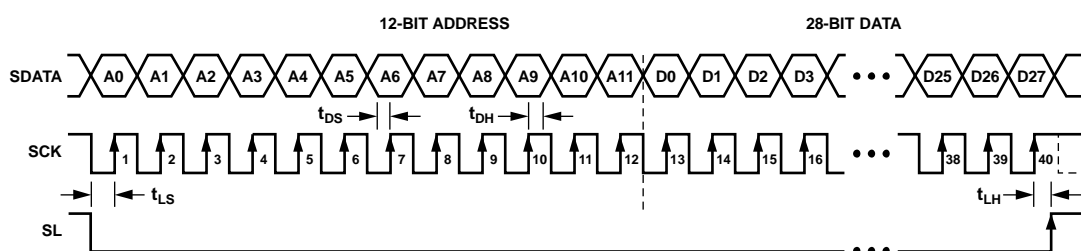

#### NOTES

1. SDATA BITS ARE LATCHED ON SCK RISING EDGES. SCK CAN IDLE HIGH OR LOW BETWEEN WRITE OPERATIONS.
2. ALL 40 BITS MUST BE WRITTEN: 12 BITS FOR ADDRESS AND 28 BITS FOR DATA.
3. IF THE REGISTER LENGTH IS <28 BITS, 0s MUST BE USED TO COMPLETE THE 28-BIT DATA LENGTH.
4. NEW DATA VALUES ARE UPDATED IN THE SPECIFIED REGISTER LOCATION AT DIFFERENT TIMES, DEPENDING ON THE PARTICULAR REGISTER WRITTEN TO. SEE THE UPDATING NEW REGISTER VALUES SECTION FOR MORE INFORMATION.

Figure 113. Serial Write Operation

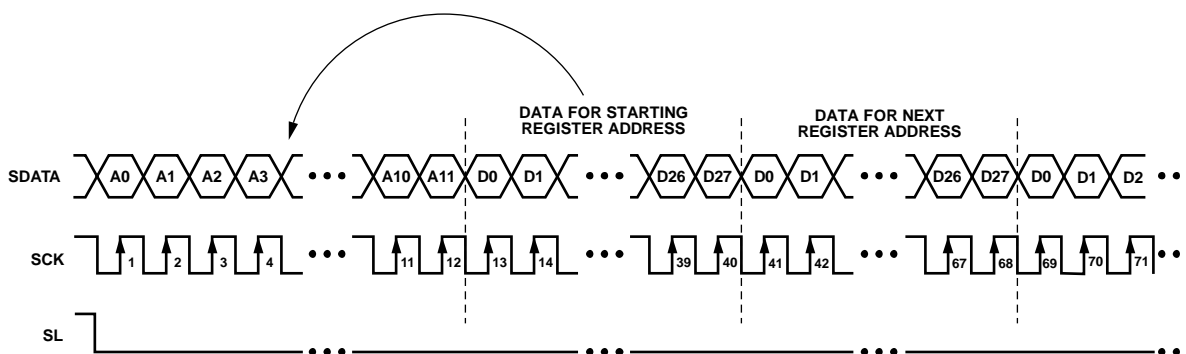

#### NOTES

1. MULTIPLE SEQUENTIAL REGISTERS CAN BE LOADED CONTINUOUSLY.
2. THE FIRST (LOWEST) REGISTER ADDRESS IS WRITTEN, FOLLOWED BY MULTIPLE 28-BIT DATA-WORDS.
3. THE ADDRESS AUTOMATICALLY INCREMENTS WITH EACH 28-BIT DATA-WORD (ALL 28 BITS MUST BE WRITTEN).
4. SL IS HELD LOW UNTIL THE LAST DESIRED REGISTER HAS BEEN LOADED.

Figure 114. Continuous Serial Write Operation

## LAYOUT OF INTERNAL REGISTERS

The AD9920A address space is divided into two register areas, as illustrated in Figure 115. In the first address space, Address 0x00 to Address 0xFF contain the registers for the AFE, miscellaneous, VD/HD, I/O and CP, timing core, shutter and GPO, and update control functions. The second address space, beginning at Address 0x400, consists of the V-pattern groups, V-sequences, and field registers. This set of registers is configurable; the user can decide how many V-pattern groups, V-sequences, and fields are used in a particular design. Therefore, the addresses for these registers vary, depending on the number of V-patterns and V-sequences chosen.

Address 0x28 specifies the total number of V-pattern groups and V-sequences used. The starting address for the V-pattern groups is always 0x400. The starting address for the V-sequences is based on the number of V-pattern groups used, with each V-pattern group occupying 48 register addresses. The starting address for the field registers depends on both the number of V-pattern groups and the number of V-sequences.

Each V-sequence occupies 40 register addresses, and each field occupies 16 register addresses.

The starting address for the V-sequences is equal to 0x400 plus the number of V-pattern groups multiplied by 48. The starting address for the fields is equal to the starting address of the V-sequences plus the number of V-sequences multiplied by 40. The V-pattern, V-sequence, and field registers must always occupy a continuous block of addresses.

Figure 116 shows an example in which three V-pattern groups, four V-sequences, and two fields are used. The starting address for the V-pattern groups is always 0x400. Because VPATNUM = 3, the V-pattern groups occupy 144 address locations. The start of the V-sequence registers is 0x490 (that is, 0x400 + 144). With SEQNUM = 4, the V-sequences occupy 160 address locations. Therefore, the field registers begin at 0x530 (that is, 0x490 + 160).

The AD9920A address space contains many unused addresses. Undefined addresses between Address 0x00 and Address 0xFF should not be written to; otherwise, the AD9920A may operate incorrectly. Continuous register writes should be performed carefully so that undefined registers are not written to.

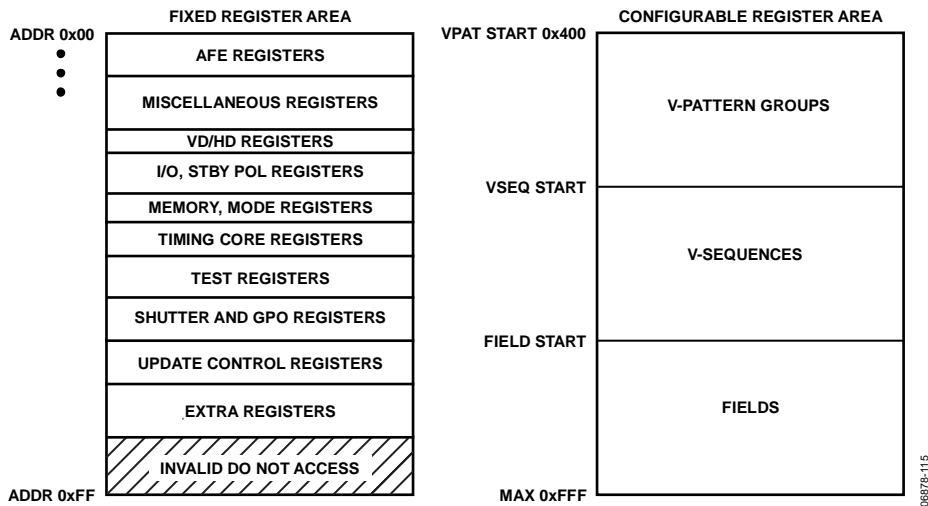

Figure 115. Layout of AD9920A Registers

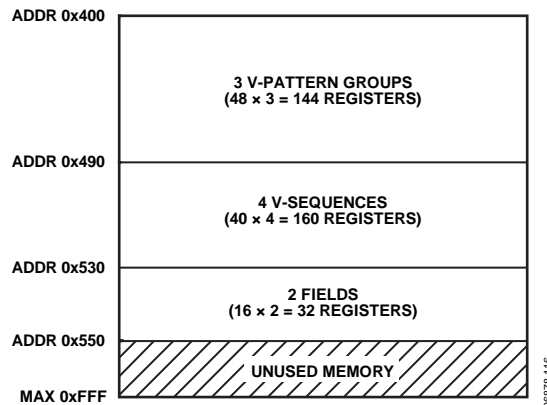

Figure 116. Example Register Configuration

## UPDATING NEW REGISTER VALUES

The AD9920A internal registers are updated at different times, depending on the particular register. Table 51 summarizes the four register update types: SCK, VD, SG line, and SCP. Tables in the Complete Register Listing section contain an update type column that identifies when each register is updated.

**Table 51. Register Update Locations**

Update Type	Description
SCK	When the 28th data bit (D27) is clocked in, the register is immediately updated.
VD	Register is updated at the next VD falling edge. VD-updated registers can be delayed further by using the update register at Address 0x17. Field registers are not affected by the update register.
SG Line	Register is updated at the HD falling edge at the start of the SG active line.
SCP	Register is updated at the next SCP when the register is used.

### SCK-Updated Registers

As soon as the 28th data bit (D27) is clocked in, some registers are immediately updated. These registers are used for functions that do not require gating with the next VD boundary, such as power-up and reset functions.

### VD-Updated Registers

More registers are updated at the next VD falling edge. By updating these values at the next VD edge, the current field is not corrupted, and the new register values are applied to the next field. The VD update can be further delayed past the VD falling edge by using the update register (Address 0x17). This

delays the VD-updated register updates to any HD line in the field. Note that the field registers are not affected by the update register.

### SG Line-Updated Registers

A few of the shutter registers are updated at the HD falling edge at the start of the SG active line. These registers control the SUBCK signal so that the SUBCK output is not updated until the SG line occurs.

### SCP-Updated Registers

At the next SCP where they are used, the V-pattern group and V-sequence registers are updated. For example, in Figure 117 this field has selected Region 1 to use VSEQ3 for the vertical outputs. This means that a write to any of the VSEQ3 registers or to any of the V-pattern group registers that are referenced by VSEQ3, updates at SCP1. If multiple writes are done to the same register, the last one done before SCP1 is the one that is updated. Likewise, register writes to any VSEQ5 registers are updated at SCP2, and register writes to any VSEQ8 registers are updated at SCP3.

### Caution

It is recommended that the registers in the configurable address area not be written within 36 pixels of any HD falling edge where a sequence change position (SCP) occurs. See Figure 107 for an example of what this inhibit area looks like in master and slave modes. This restriction applies to the V-pattern, V-sequence, and field registers. As shown in Figure 117, writing to these registers before the VD falling edge typically avoids loading these registers during SCP locations.

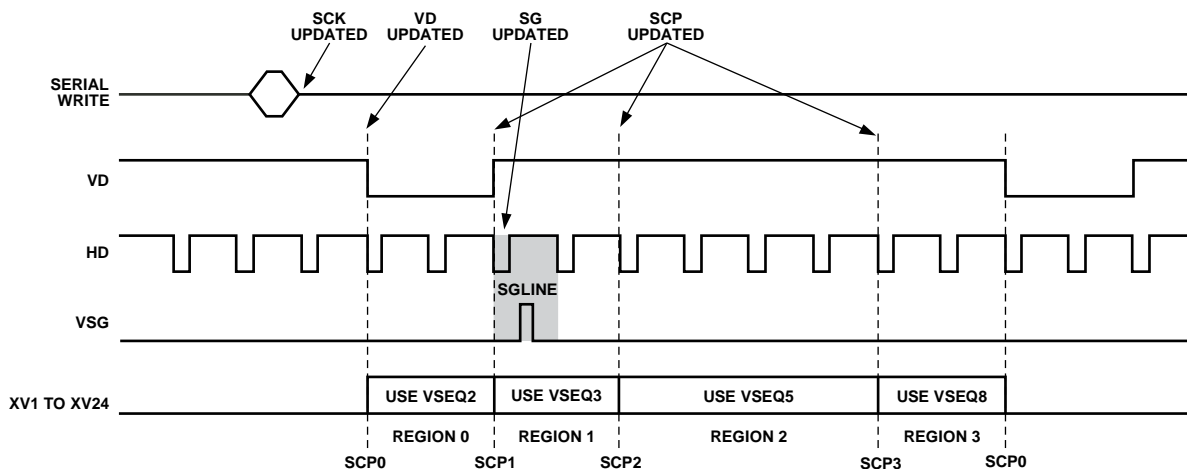

Figure 117. Register Update Locations (See Table 51 for Definitions)

06876-117

## COMPLETE REGISTER LISTING

When an address contains fewer than 28 data bits, all remaining bits must be written as 0s.

Table 52. AFE Registers

Address	Data Bits	Default Value	Default Update Type	Name	Description
0x00	[1:0]	0x03	SCK	STANDBY	Standby modes. 0 = normal operation (full power). 1 = Standby1 mode. 2 = Standby2 mode. 3 = Standby3 mode (lowest power).
	[2]	0x01		CLPENABLE	0 = disable OB clamp. 1 = enable OB clamp.
	[3]	0		CLPSPEED	0 = select normal OB clamp settling. 1 = select fast OB clamp settling.
	[4]	0		FASTUPDATE	0 = ignore CDS gain. 1 = very fast clamping when CDS gain is updated.
	[5]	0		PBLK_LVL	0 = blank data outputs to 0 during PBLK. 1 = blank data outputs to programmed clamp level during PBLK.
	[6]	0		DCBYP	0 = enable input dc restore circuit during PBLK. 1 = disable input dc restore circuit during PBLK.
0x01	[0]	0	SCK	DOUTDISABLE	0 = data outputs are driven. 1 = data outputs are three-stated.
	[1]	0		DOUTLATCH	0 = latch data outputs using DOUTPHASE register setting. 1 = output latch is transparent.
	[2]	0		GRAYEN	1 = enable gray coding of digital data output.
	[3]	0		Test	Set to 0.
0x02	[0]	0	VD	Test	Do not access, or set to 0.
0x03	[23:0]	0xFFFFFFFF	VD	Test	Do not access, or set to 0xFFFFFFFF.
0x04	[2:0]	0	VD	CDSGAIN	CDS gain setting. 0 = -3 dB. 4 = 0 dB. 6 = +3 dB. 7 = +6 dB. All other values are invalid.
0x05	[9:0]	0x0F	VD	VGAGAIN	VGA gain. 6 dB to 42 dB (0.035 dB per step).
0x06	[9:0]	0x1EC	VD	CLAMPLEVEL	Optical black clamp level. 0 LSB to 255 LSB (0.25 LSB per step).
0x07	[27:0]	0	VD	Test	Do not access, or set to 0.
0x08	[27:0]	0	VD	Test	Do not access, or set to 0.
0x09	[27:0]	0	VD	Test	Do not access, or set to 0.
0x0A	[27:0]	0	VD	Test	Do not access, or set to 0.
0x0B	[27:0]	0	SCK	UNUSED	Do not access, or set to 0.
0x0C	[27:0]	0	SCK	Test	Do not access, or set to 0.
0x0D	[0]	0	VD	CLIDIVIDE	0 = do not divide CLI frequency. 1 = divide CLI frequency by 2.
	[7:1]	0		Test	Do not access, or set to 0.
0x0E	[7:0]	0	SCK	Test	Set to 0.
	[8]	0		VDHD_IE	VD/HD input enable. Set to 1 to enable VD/HD inputs for slave mode.
0x0F	[27:0]	0	VD	Test	Set to 0.

Table 53. Miscellaneous Registers

Address	Data Bits	Default Value	Default Update Type	Name	Description
0x10	[0]	0	SCK	SW_RST	Software reset. Bit self-clears to 0 when a reset occurs. 1 = reset Address 0x00 to Address 0xFF back to default values.
0x11	[0]	0	VD	OUT_CONTROL	0 = make all outputs dc inactive. 1 = enable outputs at next VD edge.
0x12	[0]	0x01	SCK	RST_SYNC_EN	0 = configure SYNC/RST as SYNC pin. 1 = configure SYNC/RST as RST pin (default configuration is RST).
	[4:1]	0		Test	Test mode only. Must be set to 0.
0x13	[0]	0x01	SCK	SYNCENABLE	1 = external synchronization enable. Configure SYNC/RST pin as an input.
	[1]	0		SYNCPOL	SYNC active polarity.
	[2]	0		SYNCSUSPEND	Suspend clocks during SYNC active pulse. 0 = don't suspend. 1 = suspend.
	[3]	0		ENH_SYNC_EN	1 = enable enhanced sync/shutter operations.
	[4]	0		SYNC_MASK_HD	1 = mask HD during SYNCSUSPEND.
	[5]	0x01		SYNC_MASK_VD	1 = mask VD during SYNCSUSPEND.
	[6]	0x01		SYNC_MASK_V	1 = mask XV outputs during SYNCSUSPEND.
	[7]	0		Test	Test mode only. Must be set to 0.
	[12:8]	0		Test	Test mode only. Must be set to 0.
	[13]	0		Test	Test mode only. Must be set to 0.
	[14]	0		SYNC_EDGE_EN	1 = enable SYNC to use only one edge to reset.
	[15]	0		SYNC_RST_SHUTEN	1 = enable reset of the shutter control after SYNC operation occurs.
	[16]	0		GPO_RST_SYNC	1 = reset shutter and GPO control at SYNC operation.
	[17]	0		SYNC_CNT_INC	1 = increment field counter by 1 when SYNC occurs. 0 = reset to 0.
	[19:18]	0		UNUSED	Set unused bits to 0.
	[23:20]	0		Test	Test mode only. Must be set to 0.
	[24]	0		SWSYNC	1 = initiate software SYNC event (self-clears to 0 after SYNC).
	[25]	0		REG_RST_SHUT	1 = force shutter control to reset until REG_RST_SHUT = 0.
0x14	[0]	0	SCK	TGCORE_RST	Timing core reset bar. 0 = reset TG core. 1 = resume operation.
0x15	[0]	0	SCK	OSC_RST	CLO oscillator reset bar. 0 = oscillator in power-down state. 1 = resume oscillator operation.
0x16	[27:0]	0x01	SCK	Test	Test mode only. Must be set to 1.
0x17	[12:0]	0	SCK	Update	Serial update line. Sets the line (HD) within the field to update the VD-updated registers.
	[13]	0		PREVENTUP	Prevents the update of the VD-updated registers. 0 = normal update. 1 = prevent update of VD-updated registers.
0x18	[27:0]	0	SCK	Test	Test mode only. Set to 0.
0x19	[27:0]	0	SCK	Test	Test mode only. Set to 0.
0x1A	[27:0]	0	SCK	Test	Test mode only. Set to 0.
0x1B	[27:0]	0x0A	SCK	Test	Test mode only. Set to 0x0A.
0x1C	[23:0]	0	SCK	VSGSELECT	1 = each bit selects XV pulses for use as VSG pulses.
0x1D	[23:0]	0	SCK	VSGMASK_CTL	VSG masking. Overrides settings in field registers when enabled.
	[24]	0		VSGMASK_CTL_EN	0 = disable VSGMASK_CTL bits. VSG masking is controlled by field registers. 1 = enable VSGMASK_CTL bits to control VSG masking.
0x1E	[27]	0	SCK	UNUSED	Do not access, or set to 0.
0x1F	[0]	0x01	SCK	HCNT14_EN	1 = enable 14-bit H-counter.
	[1]	0x01		PBLK_MASK_EN	1 = disable clamp operation if PBLK is active at the same time as CLPOB.

# AD9920A

Table 54. VD/HD Registers

Address	Data Bits	Default Value	Default Update Type	Name	Description
0x20	[0]	0	SCK	MASTER	VD/HD master or slave mode. 0 = slave mode, 1 = master mode.
0x21	[0]	0	VD	VDHDPOL	VD/HD active polarity. 0 = low, 1 = high.
0x22	[12:0]	0	VD	HDRISE	Rising edge location for HD. Minimum value is 36 pixels.
	[25:13]	0		VDRISE	Rising edge location for VD.

Table 55. I/O Registers

Address	Data Bits	Default Value	Default Update Type	Name	Description
0x23	[0]	0	SCK	OSC_NVR	Oscillator normal voltage range. Set to match CLIVDD supply voltage. 0 = 1.8 V. 1 = 3.3 V.
	[1]	0		XV_NVR	XV output normal voltage range. Set to match VDVDD supply voltage. 0 = 1.8 V. 1 = 3.3 V.
	[2]	0		IO_NVR	I/O normal voltage range. Set to match IOVDD supply voltage. 0 = 1.8 V. 1 = 3.3 V.
	[3]	0		DATA_NVR	Data pin normal voltage range. Set to match DRVDD supply voltage. 0 = 1.8 V I/O. 1 = 3.3 V I/O.
	[4]	0		Test	Test use only. Set to 0.
	[5]	0		Test	Test use only. Set to 0.
	[6]	0		Test	Test use only. Set to 0.
0x24	[4:0]	0x01	SCK	HCLKMODE	Selects HCLK output configuration. Should be written to desired value. Note that all other settings are invalid. 0x01 = Mode 1. 0x02 = Mode 2. 0x04 = Mode 3. 0x10 = 3-phase HCLK mode.
	[5]	0		Test	Test use only. Set to 0.
0x25	[24:0]	0	SCK	VT_STBY12	Bits[23:0]: Standby1 and Standby2 polarity for XV[23:0]. Bit 24: Standby1 and Standby2 polarity for XSUBCK. Settings also apply when OUT_CONTROL = low.
0x26	[24:0]	0	SCK	VT_STBY3	Bits[23:0]: Standby3 polarity for XV[23:0]. Bit 24: Standby3 polarity for XSUBCK.
0x27	[7:0]	0	SCK	GP_STDBY12	Standby1 and Standby2 polarity for GPO outputs. Settings also apply when OUT_CONTROL = low.
	[15:8]	0		GP_STDBY3	Standby3 polarity for GPO outputs.

Table 56. Memory Configuration and Mode Registers

Address	Data Bits	Default Value	Update Type	Name	Description
0x28	[4:0]	0	SCK	VPATNUM	Total number of V-pattern groups.
	[9:5]	0		SEQNUM	Total number of V-sequences.
0x29	[27]	0	SCK	UNUSED	Do not access, or set to 0.
0x2A	[2:0]	0	SCK	Mode	Total number of fields in the mode register.
0x2B	[4:0]	0	SCK	FIELD1	Selected first field in the mode register.
	[9:5]	0		FIELD2	Selected second field in the mode register.
	[14:10]	0		FIELD3	Selected third field in the mode register.
	[19:15]	0		FIELD4	Selected fourth field in the mode register.
	[24:20]	0		FIELD5	Selected fifth field in the mode register.

Address	Data Bits	Default Value	Update Type	Name	Description
0x2C	[4:0]	0	SCK	FIELD6	Selected sixth field in the mode register.
	[9:5]	0		FIELD7	Selected seventh field in the mode register.
0x2D	[27]	0	SCK	UNUSED	Do not access, or set to 0.
0x2E	[27]	0	SCK	UNUSED	Do not access, or set to 0.
0x2F	[27]	0	SCK	UNUSED	Do not access, or set to 0.

Table 57. Timing Core Registers

Address	Data Bits	Default Value	Update Type	Name	Description
0x30	[5:0]	0	SCK	H1POSLOC	H1 rising edge location in HCLK Mode 1, Mode 2, and Mode 3. Phase 3 (H7/H8) rising edge location in 3-phase mode.
	[13:8]	0x20		H1NEGLOC	H1 falling edge location in HCLK Mode 1, Mode 2, and Mode 3. Phase 3 (H7/H8) falling edge location in 3-phase mode.
	[16]	0x01		Test	Test use only. Set to 1.
0x31	[5:0]	0	SCK	H2POSLOC	H2 rising edge location in HCLK Mode 2. H5 rising edge location in HCLK Mode 3. Phase 2 (H5/H6) rising edge location in 3-phase mode.
	[13:8]	0x20		H2NEGLOC	H2 falling edge location in HCLK Mode 2. H5 falling edge location in HCLK Mode 3. Phase 2 (H5/H6) falling edge location in 3-phase mode.
	[16]	0x01		Test	Test use only. Set to 1.
0x32	[5:0]	0	SCK	HLPOSLOC	HL rising edge location.
	[13:8]	0x20		HLNEGLOC	HL falling edge location.
	[16]	0x01		Test	Test use only. Set to 1.
0x33	[5:0]	0	SCK	H3P1POSLOC	Phase 1 (H1/H2) rising edge location in 3-phase mode.
	[13:8]	0x20		H3P1NEGLOC	Phase 1 (H1/H2) falling edge location in 3-phase mode.
	[16]	0x01		Test	Test use only. Set to 1.
0x34	[5:0]	0	SCK	RGPOSLOC	RG rising edge location.
	[13:8]	0x10		RGNEGLOC	RG falling edge location.
	[16]	0x01		Test	Test use only. Set to 1.
0x35	[0]	0	SCK	H1HBLKRETIME	Retime H1 HBLK to internal clock. Enabling retime adds one half cycle delay to HBLK position. 0 = no retime. 1 = retime.
	[1]	0		H2HBLKRETIME	Retime H2 HBLK to internal clock.
	[2]	0		HLHBLKRETIME	Retime HL HBLK to internal clock.
	[3]	0		H3PHBLKRETIME	Retime H3 HBLK to internal clock.
	[7:4]	0		HCLK_WIDTH	Enables wide H-clocks during HBLK interval. Set to 0 to disable.
	[8]	0		Test	Test use only. Set to 0.
	[9]	0		HLHBLK	1 = enable HBLK for HL.
	[19:10]	0		Test	Test use only. Set to 0.
	[20]	0		H1FINERETIME	Adds one additional retime operation to H1 HBLK signal.
	[21]	0		H2FINERETIME	Adds one additional retime operation to H2 HBLK signal.
	[22]	0		HLFINERETIME	Adds one additional retime operation to HL HBLK signal.
[23]	0	H3PFINERETIME	Adds one additional retime operation to H3P HBLK signal (3-phase mode).		

# AD9920A

Address	Data Bits	Default Value	Update Type	Name	Description
0x36	[2:0]	0x01	SCK	H1DRV	H1 drive strength. 0 = off. 1 = 4.3 mA. 2 = 8.6 mA. 3 = 12.9 mA. 4 = 17.3 mA. 5 = 21.6 mA. 6 = 25.9 mA. 7 = 30.2 mA.
	[6:4]	0x1		H2DRV	H2 drive strength (same range as H1DRV).
	[10:8]	0x1		H3DRV	H3 drive strength (same range as H1DRV).
	[14:12]	0x1		H4DRV	H4 drive strength (same range as H1DRV).
	[18:16]	0x1		HLDRV	HL drive strength. 0 = off. 1 = 4.3 mA. 2 = 8.6 mA. 3 = 12.9 mA. 4 = 4.3 mA. 5 = 8.6 mA. 6 = 12.9 mA. 7 = 17.3 mA.
[22:20]	0x1	RGDRV	RG drive strength (same range as HLDRV).		
0x37	[2:0]	0x1	SCK	H5DRV	H5 drive strength (same range as H1DRV).
	[6:4]	0x1		H6DRV	H6 drive strength (same range as H1DRV).
	[10:8]	0x1		H7DRV	H7 drive strength (same range as H1DRV).
	[14:12]	0x1		H8DRV	H8 drive strength (same range as H1DRV).
	[18:16]	0x1		Test	Test use only. Set to 1.
	[22:20]	0x1		Test	Test use only. Set to 1.
0x38	[5:0]	0	SCK	SHDLOC	SHD sampling edge location.
	[13:8]	0x20		SHPLOC	SHP sampling edge location.
	[21:16]	0x10		SHPWIDTH	SHP width (controls input dc restore switch active time).
0x39	[5:0]	0	SCK	DOUTPHASEP	DOUT phase control, positive edge. Specifies location of DOUT.
	[13:8]	0x20		DOUTPHASEN	DOUT phase control, negative edge. Always set to DOUTPHASEP + 32 edges to maintain 50% duty cycle of internal DOUTPHASE clocking.
	[16]	0		DCLKMODE	DCLK mode. 0 = DCLK tracks DOUT. 1 = DCLK phase is fixed.
	[18:17]	0		Test	Test use only. Set to 0.
	[19]	0		DCLKINV	Invert DCLK output. 0 = no inversion. 1 = inversion of DCLK.
[22:20]	0	Test	Test use only. Set to 0.		
0x3A	[27]	0	SCK	Test	Do not access, or set to 0.
0x3B	[27]	0	SCK	UNUSED	Do not access, or set to 0.
0x3C	[27]	0	SCK	Test	Do not access, or set to 0.
0x3D	[27]	0	SCK	UNUSED	Do not access, or set to 0.
0x3E	[27]	0	SCK	Test	Do not access, or set to 0.
0x3F	[27]	0	SCK	UNUSED	Do not access, or set to 0.

**Table 58. Test Registers—Do Not Access**

Address	Data Bits	Default Value	Update Type	Name	Description
0x40 to 0x6F					Test registers. Do not access.

Table 59. Shutter and GPO Registers

Address	Data Bits	Default Value	Update Type	Name	Description
0x70	[2:0]	0	VD	PRIMARY_ACTION	Select action for primary and secondary counters. 0 = idle (do nothing): autoreset on VD. 1 = activate counter (primary: automatic exposure/read). 2 = RapidShot: wrap/repeat counter. 3 = ShotTimer: delay start of count. 4 = ShotTimer with RapidShot. 5 = SLR exposure (manual). 6 = SLR read (manual). 7 = force to idle.
	[5:3]	0		SECOND_ACTION	
0x70	[13:6]	0	VD	MANUAL_TRIG	1: manual trigger for GP signals when Protocol 1 is selected. Bit 6: GP1 manual trigger. Bit 13: GP8 manual trigger.
0x71	[12:0]	0	VD	PRIMARY_MAX	Primary counter maximum value. Secondary counter maximum value. Mask VD/HD during counter operation.
	[24:13]	0		SECOND_MAX	
	[27:25]	0		VDHD_MASK	
0x72	[12:0]	0	VD	PRIMARY_DELAY	Number of fields to delay before the next primary count (exposure) starts. For ShotTimer with RapidShot, the delay value is used between each repetition. For ShotTimer with RapidShot, use the primary delay value only before the first count (exposure). Number of fields to delay before the next secondary count (exposure) starts. For ShotTimer with RapidShot, the delay value is used between each repetition. For ShotTimer with RapidShot, use the secondary delay value only before the first count (exposure).
	[13]	0		PRIMARY_SKIP	
	[26:14]	0		SECOND_DELAY	
	[27]	0		SECOND_SKIP	
0x73	[2:0]	0	VD	GP1_PROTOCOL	Selects protocol for each general-purpose signal. 0 = idle. 1 = no counter association. Use MANUAL_TRIG bits to enable each GP signal. 2 = test use only. 3 = test use only. 4 = link to mode counter. 5 = link to primary counter. 6 = link to secondary counter. 7 = keep on.
	[5:3]	0		GP2_PROTOCOL	
	[8:6]	0		GP3_PROTOCOL	
	[11:9]	0		GP4_PROTOCOL	
	[14:12]	0		GP5_PROTOCOL	
	[17:15]	0		GP6_PROTOCOL	
	[20:18]	0		GP7_PROTOCOL	
	[23:21]	0		GP8_PROTOCOL	
0x74	[12:0]	0	VD	SGMASK_NUM	Exposure duration (number of fields to mask SG) for LS operation. Exposure + readout duration (number of fields to mask SUBCK) for LS. 0 = SUBCK HP toggles and the registers involved in SUBCK masking (Register 0x78 and Register 0x74, Bits[27:13]) are updated at SG line. 1 = updated at update line (VD updated). Skip the SUBCK mask for the first exposure field only.
	[25:13]	0	VD/SG	SUBCKMASK_NUM	
	[26]	0x01	VD/SG	SUBCKTOG_UPDATE	
	[27]	0	VD/SG	SUBCKMASK_SKIP1	
0x75	[0]	0	VD/SG	Test	Test purpose only. Must be set to 0. Number of lines after VSG line to begin SUBCK pulses. Number of SUBCK pulses per field. Must be set less than VDLEN. Suppress the SG and allow SUBCK to finish at SUBCKNUM.
	[13:1]	0		SUBCKSUPPRESS	
	[26:14]	0		SUBCKNUM	
	[27]	0		SG_SUPPRESS	
0x76	[0]	0	VD/SG	SUBCK_POL	SUBCK start polarity. Test use only. Must be set to 0.
	[1]	0		TESTMODE	
0x77	[13:0]	0	VD/SG	SUBCK_TOG1	SUBCK Toggle Position 1. SUBCK Toggle Position 2.
	[27:14]	0		SUBCK_TOG2	
0x78	[13:0]	0	VD/SG	SUBCKHP_TOG1	High precision SUBCK Toggle Position 1. High precision SUBCK Toggle Position 2.
	[27:14]	0		SUBCKHP_TOG2	
0x79	[25:0]	0	VD	TESTMODE	Test use only. Must be set to 0.

# AD9920A

Address	Data Bits	Default Value	Update Type	Name	Description
0x7A	[0]	0	VD	GP1_POL	GP1 low/high start polarity.
	[1]	0		GP2_POL	GP2 low/high start polarity.
	[2]	0		GP3_POL	GP3 low/high start polarity.
	[3]	0		GP4_POL	GP4 low/high start polarity.
	[4]	0		GP5_POL	GP5 low/high start polarity.
	[5]	0		GP6_POL	GP6 low/high start polarity.
	[6]	0		GP7_POL	GP7 low/high start polarity.
	[7]	0		GP8_POL	GP8 low/high start polarity.
	[8]	0x01		SEL_GP1	1 = GP1 signal is selected for GPO1 output. 0 = internal signal is selected.
	[9]	0x01		SEL_GP2	1 = GP2 signal is selected for GPO2 output. 0 = internal signal is selected.
	[10]	0x01		SEL_GP3	1 = GP3 signal is selected for GPO3 output. 0 = internal signal is selected.
	[11]	0x01		SEL_GP4	1 = GP4 signal is selected for GPO4 output. 0 = XSUBCK is selected.
	[12]	0x01		SEL_GP5	1 = GP5 signal is selected for GPO5 output. 0 = XV21 is selected.
	[13]	0x01		SEL_GP6	1 = GP6 signal is selected for GPO6 output. 0 = XV22 is selected.
	[14]	0x01		SEL_GP7	1 = GP7 signal is selected for GPO7 output. 0 = XV23 is selected.
	[15]	0x01		SEL_GP8	1 = GP8 signal is selected for GPO8 output. 0 = XV24 is selected.
	[23:16]	0		GPO_OUTPUT_EN	1 = GPO enabled. 0 = GPO is high-Z (default).
[24]	0	GPO5_OVERRIDE	1 = when GPO5 is configured as an input, this register overrides the internal OUT_CONT.		
[25]	0	GPO6_OVERRIDE	1 = when GPO6 is configured as an input, this register overrides the internal HBLK.		
[26]	0	GPO7_OVERRIDE	1 = when GPO7 is configured as an input, this register overrides the internal CLPOB.		
[27]	0	GPO8_OVERRIDE	1 = when GPO8 is configured as an input, this register overrides the internal PBLK.		
0x7B	[7:0]	0	VD	GPx_USE_LUT	Enable LUT for each GPO signal. 1 = enable. 0 = disable (use normal GP signal).
	[11:8]	0000		LUT_FOR_GP12	Two-input lookup table results.
	[15:12]	0000		LUT_FOR_GP34	Examples: {LUT_FOR_GP12} ← [GP2:GP1].
	[19:16]	0000		LUT_FOR_GP56	{0110} = GP2 XOR GP1; {1110} = GP2 OR GP1.
	[23:20]	0000		LUT_FOR_GP78	{0111} = GP2 NAND GP1; {1000} = GP2 AND GP1.
0x7C	[12:0]	0	VD	GP1_TOG1_FD	General-Purpose Signal 1, first toggle position, field location.
	[25:13]	0		GP1_TOG1_LN	General-Purpose Signal 1, first toggle position, line location.
0x7D	[12:0]	0	VD	GP1_TOG1_PX	General-Purpose Signal 1, first toggle position, pixel location.
	[25:13]	0		GP1_TOG2_FD	General-Purpose Signal 1, second toggle position, field location.
0x7E	[12:0]	0	VD	GP1_TOG2_LN	General-Purpose Signal 1, second toggle position, line location.
	[25:13]	0		GP1_TOG2_PX	General-Purpose Signal 1, second toggle position, pixel location.
0x7F	[12:0]	0	VD	GP1_TOG3_FD	General-Purpose Signal 1, third toggle position, field location.
	[25:13]	0		GP1_TOG3_LN	General-Purpose Signal 1, third toggle position, line location.
0x80	[12:0]	0	VD	GP1_TOG3_PX	General-Purpose Signal 1, third toggle position, pixel location.
	[25:13]	0		GP1_TOG4_FD	General-Purpose Signal 1, fourth toggle position, field location.
0x81	[12:0]	0	VD	GP1_TOG4_LN	General-Purpose Signal 1, fourth toggle position, line location.
	[25:13]	0		GP1_TOG4_PX	General-Purpose Signal 1, fourth toggle position, pixel location.
0x82	[12:0]	0	VD	GP2_TOG1_FD	General-Purpose Signal 2, first toggle position, field location.
	[25:13]	0		GP2_TOG1_LN	General-Purpose Signal 2, first toggle position, line location.
0x83	[12:0]	0	VD	GP2_TOG1_PX	General-Purpose Signal 2, first toggle position, pixel location.
	[25:13]	0		GP2_TOG2_FD	General-Purpose Signal 2, second toggle position, field location.
0x84	[12:0]	0	VD	GP2_TOG2_LN	General-Purpose Signal 2, second toggle position, line location.
	[25:13]	0		GP2_TOG2_PX	General-Purpose Signal 2, second toggle position, pixel location.

Address	Data Bits	Default Value	Update Type	Name	Description
0x85	[12:0]	0	VD	GP2_TOG3_FD	General-Purpose Signal 2, third toggle position, field location.
	[25:13]	0		GP2_TOG3_LN	General-Purpose Signal 2, third toggle position, line location.
0x86	[12:0]	0	VD	GP2_TOG3_PX	General-Purpose Signal 2, third toggle position, pixel location.
	[25:13]	0		GP2_TOG4_FD	General-Purpose Signal 2, fourth toggle position, field location.
0x87	[12:0]	0	VD	GP2_TOG4_LN	General-Purpose Signal 2, fourth toggle position, line location.
	[25:13]	0		GP2_TOG4_PX	General-Purpose Signal 2, fourth toggle position, pixel location.
0x88	[12:0]	0	VD	GP3_TOG1_FD	General-Purpose Signal 3, first toggle position, field location.
	[25:13]	0		GP3_TOG1_LN	General-Purpose Signal 3, first toggle position, line location.
0x89	[12:0]	0	VD	GP3_TOG1_PX	General-Purpose Signal 3, first toggle position, pixel location.
	[25:13]	0		GP3_TOG2_FD	General-Purpose Signal 3, second toggle position, field location.
0x8A	[12:0]	0	VD	GP3_TOG2_LN	General-Purpose Signal 3, second toggle position, line location.
	[25:13]	0		GP3_TOG2_PX	General-Purpose Signal 3, second toggle position, pixel location.
0x8B	[12:0]	0	VD	GP3_TOG3_FD	General-Purpose Signal 3, third toggle position, field location.
	[25:13]	0		GP3_TOG3_LN	General-Purpose Signal 3, third toggle position, line location.
0x8C	[12:0]	0	VD	GP3_TOG3_PX	General-Purpose Signal 3, third toggle position, pixel location.
	[25:13]	0		GP3_TOG4_FD	General-Purpose Signal 3, fourth toggle position, field location.
0x8D	[12:0]	0	VD	GP3_TOG4_LN	General-Purpose Signal 3, fourth toggle position, line location.
	[25:13]	0		GP3_TOG4_PX	General-Purpose Signal 3, fourth toggle position, pixel location.
0x8E	[12:0]	0	VD	GP4_TOG1_FD	General-Purpose Signal 4, first toggle position, field location.
	[25:13]	0		GP4_TOG1_LN	General-Purpose Signal 4, first toggle position, line location.
0x8F	[12:0]	0	VD	GP4_TOG1_PX	General-Purpose Signal 4, first toggle position, pixel location.
	[25:13]	0		GP4_TOG2_FD	General-Purpose Signal 4, second toggle position, field location.
0x90	[12:0]	0	VD	GP4_TOG2_LN	General-Purpose Signal 4, second toggle position, line location.
	[25:13]	0		GP4_TOG2_PX	General-Purpose Signal 4, second toggle position, pixel location.
0x91	[12:0]	0	VD	GP4_TOG3_FD	General-Purpose Signal 4, third toggle position, field location.
	[25:13]	0		GP4_TOG3_LN	General-Purpose Signal 4, third toggle position, line location.
0x92	[12:0]	0	VD	GP4_TOG3_PX	General-Purpose Signal 4, third toggle position, pixel location.
	[25:13]	0		GP4_TOG4_FD	General-Purpose Signal 4, fourth toggle position, field location.
0x93	[12:0]	0	VD	GP4_TOG4_LN	General-Purpose Signal 4, fourth toggle position, line location.
	[25:13]	0		GP4_TOG4_PX	General-Purpose Signal 4, fourth toggle position, pixel location.
0x94	[12:0]	0	VD	GP5_TOG1_FD	General-Purpose Signal 5, first toggle position, field location.
	[25:13]	0		GP5_TOG1_LN	General-Purpose Signal 5, first toggle position, line location.
0x95	[12:0]	0	VD	GP5_TOG1_PX	General-Purpose Signal 5, first toggle position, pixel location.
	[25:13]	0		GP5_TOG2_FD	General-Purpose Signal 5, second toggle position, field location.
0x96	[12:0]	0	VD	GP5_TOG2_LN	General-Purpose Signal 5, second toggle position, line location.
	[25:13]	0		GP5_TOG2_PX	General-Purpose Signal 5, second toggle position, pixel location.
0x97	[12:0]	0	VD	GP5_TOG3_FD	General-Purpose Signal 5, third toggle position, field location.
	[25:13]	0		GP5_TOG3_LN	General-Purpose Signal 5, third toggle position, line location.
0x98	[12:0]	0	VD	GP5_TOG3_PX	General-Purpose Signal 5, third toggle position, pixel location.
	[25:13]	0		GP5_TOG4_FD	General-Purpose Signal 5, fourth toggle position, field location.
0x99	[12:0]	0	VD	GP5_TOG4_LN	General-Purpose Signal 5, fourth toggle position, line location.
	[25:13]	0		GP5_TOG4_PX	General-Purpose Signal 5, fourth toggle position, pixel location.
0x9A	[12:0]	0	VD	GP6_TOG1_FD	General-Purpose Signal 6, first toggle position, field location.
	[25:13]	0		GP6_TOG1_LN	General-Purpose Signal 6, first toggle position, line location.
0x9B	[12:0]	0	VD	GP6_TOG1_PX	General-Purpose Signal 6, first toggle position, pixel location.
	[25:13]	0		GP6_TOG2_FD	General-Purpose Signal 6, second toggle position, field location.
0x9C	[12:0]	0	VD	GP6_TOG2_LN	General-Purpose Signal 6, second toggle position, line location.
	[25:13]	0		GP6_TOG2_PX	General-Purpose Signal 6, second toggle position, pixel location.
0x9D	[12:0]	0	VD	GP6_TOG3_FD	General-Purpose Signal 6, third toggle position, field location.
	[25:13]	0		GP6_TOG3_LN	General-Purpose Signal 6, third toggle position, line location.

# AD9920A

Address	Data Bits	Default Value	Update Type	Name	Description
0x9E	[12:0] [25:13]	0 0	VD	GP6_TOG3_PX GP6_TOG4_FD	General-Purpose Signal 6, third toggle position, pixel location. General-Purpose Signal 6, fourth toggle position, field location.
0x9F	[12:0] [25:13]	0 0	VD	GP6_TOG4_LN GP6_TOG4_PX	General-Purpose Signal 6, fourth toggle position, line location. General-Purpose Signal 6, fourth toggle position, pixel location.
0xA0	[12:0] [25:13]	0 0	VD	GP7_TOG1_FD GP7_TOG1_LN	General-Purpose Signal 7, first toggle position, field location. General-Purpose Signal 7, first toggle position, line location.
0xA1	[12:0] [25:13]	0 0	VD	GP7_TOG1_PX GP7_TOG2_FD	General-Purpose Signal 7, first toggle position, pixel location. General-Purpose Signal 7, second toggle position, field location.
0xA2	[12:0] [25:13]	0 0	VD	GP7_TOG2_LN GP7_TOG2_PX	General-Purpose Signal 7, second toggle position, line location. General-Purpose Signal 7, second toggle position, pixel location.
0xA3	[12:0] [25:13]	0 0	VD	GP7_TOG3_FD GP7_TOG3_LN	General-Purpose Signal 7, third toggle position, field location. General-Purpose Signal 7, third toggle position, line location.
0xA4	[12:0] [25:13]	0 0	VD	GP7_TOG3_PX GP7_TOG4_FD	General-Purpose Signal 7, third toggle position, pixel location. General-Purpose Signal 7, fourth toggle position, field location.
0xA5	[12:0] [25:13]	0 0	VD	GP7_TOG4_LN GP7_TOG4_PX	General-Purpose Signal 7, fourth toggle position, line location. General-Purpose Signal 7, fourth toggle position, pixel location.
0xA6	[12:0] [25:13]	0 0	VD	GP8_TOG1_FD GP8_TOG1_LN	General-Purpose Signal 8, first toggle position, field location. General-Purpose Signal 8, first toggle position, line location.
0xA7	[12:0] [25:13]	0 0	VD	GP8_TOG1_PX GP8_TOG2_FD	General-Purpose Signal 8, first toggle position, pixel location. General-Purpose Signal 8, second toggle position, field location.
0xA8	[12:0] [25:13]	0 0	VD	GP8_TOG2_LN GP8_TOG2_PX	General-Purpose Signal 8, second toggle position, line location. General-Purpose Signal 8, second toggle position, pixel location.
0xA9	[12:0] [25:13]	0 0	VD	GP8_TOG3_FD GP8_TOG3_LN	General-Purpose Signal 8, third toggle position, field location. General-Purpose Signal 8, third toggle position, line location.
0xAA	[12:0] [25:13]	0 0	VD	GP8_TOG3_PX GP8_TOG4_FD	General-Purpose Signal 8, third toggle position, pixel location. General-Purpose Signal 8, fourth toggle position, field location.
0xAB	[12:0] [25:13]	0 0	VD	GP8_TOG4_LN GP8_TOG4_PX	General-Purpose Signal 8, fourth toggle position, line location. General-Purpose Signal 8, fourth toggle position, pixel location.
0xAC	[7:0]	0	VD	GP_LN_MODE	1 = outputs specified GP pulse on every line.
0xAD	[27]	0	VD	UNUSED	Do not access, or set to 0.
0xAE	[27]	0	VD	UNUSED	Do not access, or set to 0.
0xAF	[27]	0	VD	UNUSED	Do not access, or set to 0.

**Table 60. Update Control Registers**

Address	Data Bits	Default Value	Update Type	Name	Description
0xB0	[15:0]	0x5803	SCK	AFE_UPDT_SCK	Each bit corresponds to one address location. Bit 0: 1 = update Address 0x00 on SL rising edge. Bit 1: 1 = update Address 0x01 on SL rising edge. Bit 15: 1 = update Address 0x0F on SL rising edge.
0xB1	[15:0]	0xA7FC	SCK	AFE_UPDT_VD	Each bit corresponds to one address location. Bit 0: 1 = update Address 0x00 on VD rising edge. Bit 1: 1 = update Address 0x01 on VD rising edge. Bit 15: 1 = update Address 0x0F on VD rising edge.
0xB2	[15:0]	0xD8FD	SCK	MISC_UPDT_SCK	Enable SCK update of miscellaneous registers, Address 0x10 to Address 0x1F.
0xB3	[15:0]	0x2702	SCK	MISC_UPDT_VD	Enable VD update of miscellaneous registers, Address 0x10 to Address 0x1F.
0xB4	[15:0]	0xFFF9	SCK	VDHD_UPDT_SCK	Enable SCK update of VD/HD registers, Address 0x20 to Address 0x2F.
0xB5	[15:0]	0x0006	SCK	VDHD_UPDT_VD	Enable VD update of VD/HD registers, Address 0x20 to Address 0x2F.
0xB6	[15:0]	0xFFFF	SCK	TC_UPDT_SCK	Enable SCK update of timing core registers, Address 0x30 to Address 0x3F.
0xB7	[15:0]	0000	SCK	TC_UPDT_VD	Enable VD update of timing core registers, Address 0x30 to Address 0x3F.
0xB8	[27:0]	0x04		Test	Test register. Do not access, or write to 0x04.
0xB9	[27:0]	0		UNUSED	Do not access, or write to 0x00.

Address	Data Bits	Default Value	Update Type	Name	Description
0xBA	[27:0]	0		UNUSED	Do not access, or write to 0x00.
0xBB	[27:0]	0		UNUSED	Do not access, or write to 0x00.
0xBC	[27:0]	0		UNUSED	Do not access, or write to 0x00.
0xBD	[27:0]	0		UNUSED	Do not access, or write to 0x00.
0xBE	[27:0]	0		UNUSED	Do not access, or write to 0x00.
0xBF	[27:0]	0		UNUSED	Do not access, or write to 0x00.

Table 61. Extra Registers

Address	Data Bits	Default Value	Update	Name	Description
0xC0	[27:0]	0	VD	Test	Do not access, or write to 0x00.
0xC1	[27:0]	0	VD	Test	Do not access, or write to 0x00.
0xC2	[27:0]	0	VD	Test	Do not access, or write to 0x00.
0xC3	[7:0] [15:8]	0 0	SCK	GPO_MASK_HIGH GPO_MASK_LOW	1 = masks GPO[x] to high. Takes priority over normal operation. 1 = masks GPO[x] to low. Takes priority over normal operation and GPO_MASK_HIGH.
0xC4	[27:0]	0	VD	Test	Test register. Do not access, or set to 0.
0xC5	[27:0]	0x1516	SCK	Test	Test register. Do not access, or set to 0x1516.
0xC6	[27:0]	0		UNUSED	Unused register. Do not access, or set to 0.
0xC7	[27:0]	0		UNUSED	Unused register. Do not access, or set to 0.
0xC8	[27:0]	0	SCK	Test	Test register. Do not access, or set to 0.
0xC9	[27:0]	0xFFFF	SCK	Test	Test register. Do not access, or set to 0xFFFF.
0xCA	[27:0]	0	SCK	Test	Test register. Do not access, or set to 0.
0xCB	[27:0]	0	SCK	Test	Test register. Do not access, or set to 0.
0xCC	[27:0]	0		UNUSED	Unused register. Do not access, or set to 0.
0xCD	[27:0]	0		UNUSED	Unused register. Do not access, or set to 0.
0xCE	[27:0]	0		UNUSED	Unused register. Do not access, or set to 0.
0xCF	[27:0]	0		UNUSED	Unused register. Do not access, or set to 0.
0xD0	[27:0]	0	SCK	Test	Test register. Do not access, or set to 0.
0xD1	[19:0] [20]	0 0	SCK	Test STARTUP	Test use only. Set to 0. Must be set to 1 to start the device.
0xD2	[27:0]	0	SCK	Test	Test register. Do not access, or set to 0.
0xD3	[27:0]	0	SCK	Test	Test register. Do not access, or set to 0.
0xD4	[0] [1]  [9:2]	0 0  0	SCK	Test GPO_INT_EN  Test	Test use only. Set to 0. 1 = allow observation of internal signals at GPO1 to GPO3 outputs (must also set SEL_GPx bits low). Note that GPO4 to GPO8 continue to output normal GP toggles. GPO1: internal clock. GPO2: CLPOB. GPO3: delayed sample clock. Test use only. Set to 0.
0xD5	[27:0]	0	SCK	Test	Test use only. Set to 0.
0xD6	[27:0]	0xA10	SCK	Test	Test use only. Set to 0xA10.
0xD7	[27:0]	0	SCK	Test	Test use only. Set to 0.
0xD8	[27:0]	0x888	SCK	DOUT_STRENGTH	Controls drive strength of data output drivers. 0x888 = normal drive strength. 0x848 = weak drive strength. 0x808 = weaker drive strength.
0xD9	[27:0]	0	SCK	Test	Test use only. Set to 0.
0xDA	[27:0]	0	SCK	Test	Test use only. Set to 0.
0xDB	[27:0]		SCK	Test	Test use only. Set to 0.
0xDC	[27:0]	0xF7F	SCK	Test	Test use only. Set to 0xF7F.
0xDD	[27:0]	0x14	SCK	Test	Test use only. Set to 0x14.

# AD9920A

Address	Data Bits	Default Value	Update	Name	Description
0xDE	[27:0]	0	SCK	Test	Test use only. Set to 0.
0xDF	[27:0]	0	SCK	Test	Test use only. Set to 0.

**Table 62. V-Pattern Group (VPAT) Register Map (Default Values Are Undefined)**

Address	Data Bits	Default Value	Update Type	Name	Description
0x00	[12:0]	X	SCP	XV1TOG1	XV1 Toggle Position 1.
	[25:13]	X		XV1TOG2	XV1 Toggle Position 2.
0x01	[12:0]	X	SCP	XV1TOG3	XV1 Toggle Position 3.
	[25:13]	X		XV1TOG4	XV1 Toggle Position 4.
0x02	[12:0]	X	SCP	XV2TOG1	XV2 Toggle Position 1.
	[25:13]	X		XV2TOG2	XV2 Toggle Position 2.
0x03	[12:0]	X	SCP	XV2TOG3	XV2 Toggle Position 3.
	[25:13]	X		XV2TOG4	XV2 Toggle Position 4.
0x04	[12:0]	X	SCP	XV3TOG1	XV3 Toggle Position 1.
	[25:13]	X		XV3TOG2	XV3 Toggle Position 2.
0x05	[12:0]	X	SCP	XV3TOG3	XV3 Toggle Position 3.
	[25:13]	X		XV3TOG4	XV3 Toggle Position 4.
0x06	[12:0]	X	SCP	XV4TOG1	XV4 Toggle Position 1.
	[25:13]	X		XV4TOG2	XV4 Toggle Position 2.
0x07	[12:0]	X	SCP	XV4TOG3	XV4 Toggle Position 3.
	[25:13]	X		XV4TOG4	XV4 Toggle Position 4.
0x08	[12:0]	X	SCP	XV5TOG1	XV5 Toggle Position 1.
	[25:13]	X		XV5TOG2	XV5 Toggle Position 2.
0x09	[12:0]	X	SCP	XV5TOG3	XV5 Toggle Position 3.
	[25:13]	X		XV5TOG4	XV5 Toggle Position 4.
0x0A	[12:0]	X	SCP	XV6TOG1	XV6 Toggle Position 1.
	[25:13]	X		XV6TOG2	XV6 Toggle Position 2.
0x0B	[12:0]	X	SCP	XV6TOG3	XV6 Toggle Position 3.
	[25:13]	X		XV6TOG4	XV6 Toggle Position 4.
0x0C	[12:0]	X	SCP	XV7TOG1	XV7 Toggle Position 1.
	[25:13]	X		XV7TOG2	XV7 Toggle Position 2.
0x0D	[12:0]	X	SCP	XV7TOG3	XV7 Toggle Position 3.
	[25:13]	X		XV7TOG4	XV7 Toggle Position 4.
0x0E	[12:0]	X	SCP	XV8TOG1	XV8 Toggle Position 1.
	[25:13]	X		XV8TOG2	XV8 Toggle Position 2.
0x0F	[12:0]	X	SCP	XV8TOG3	XV8 Toggle Position 3.
	[25:13]	X		XV8TOG4	XV8 Toggle Position 4.
0x10	[12:0]	X	SCP	XV9TOG1	XV9 Toggle Position 1.
	[25:13]	X		XV9TOG2	XV9 Toggle Position 2.
0x11	[12:0]	X	SCP	XV9TOG3	XV9 Toggle Position 3.
	[25:13]	X		XV9TOG4	XV9 Toggle Position 4.
0x12	[12:0]	X	SCP	XV10TOG1	XV10 Toggle Position 1.
	[25:13]	X		XV10TOG2	XV10 Toggle Position 2.
0x13	[12:0]	X	SCP	XV10TOG3	XV10 Toggle Position 3.
	[25:13]	X		XV10TOG4	XV10 Toggle Position 4.
0x14	[12:0]	X	SCP	XV11TOG1	XV11 Toggle Position 1.
	[25:13]	X		XV11TOG2	XV11 Toggle Position 2.
0x15	[12:0]	X	SCP	XV11TOG3	XV11 Toggle Position 3.
	[25:13]	X		XV11TOG4	XV11 Toggle Position 4.
0x16	[12:0]	X	SCP	XV12TOG1	XV12 Toggle Position 1.
	[25:13]	X		XV12TOG2	XV12 Toggle Position 2.

Address	Data Bits	Default Value	Update Type	Name	Description
0x17	[12:0]	X	SCP	XV12TOG3	XV12 Toggle Position 3.
	[25:13]	X		XV12TOG4	XV12 Toggle Position 4.
0x18	[12:0]	X	SCP	XV13TOG1	XV13 Toggle Position 1.
	[25:13]	X		XV13TOG2	XV13 Toggle Position 2.
0x19	[12:0]	X	SCP	XV13TOG3	XV13 Toggle Position 3.
	[25:13]	X		XV13TOG4	XV13 Toggle Position 4.
0x1A	[12:0]	X	SCP	XV14TOG1	XV14 Toggle Position 1.
	[25:13]	X		XV14TOG2	XV14 Toggle Position 2.
0x1B	[12:0]	X	SCP	XV14TOG3	XV14 Toggle Position 3.
	[25:13]	X		XV14TOG4	XV14 Toggle Position 4.
0x1C	[12:0]	X	SCP	XV15TOG1	XV15 Toggle Position 1.
	[25:13]	X		XV15TOG2	XV15 Toggle Position 2.
0x1D	[12:0]	X	SCP	XV15TOG3	XV15 Toggle Position 3.
	[25:13]	X		XV15TOG4	XV15 Toggle Position 4.
0x1E	[12:0]	X	SCP	XV16TOG1	XV16 Toggle Position 1.
	[25:13]	X		XV16TOG2	XV16 Toggle Position 2.
0x1F	[12:0]	X	SCP	XV16TOG3	XV16 Toggle Position 3.
	[25:13]	X		XV16TOG4	XV16 Toggle Position 4.
0x20	[12:0]	X	SCP	XV17TOG1	XV17 Toggle Position 1.
	[25:13]	X		XV17TOG2	XV17 Toggle Position 2.
0x21	[12:0]	X	SCP	XV17TOG3	XV17 Toggle Position 3.
	[25:13]	X		XV17TOG4	XV17 Toggle Position 4.
0x22	[12:0]	X	SCP	XV18TOG1	XV18 Toggle Position 1.
	[25:13]	X		XV18TOG2	XV18 Toggle Position 2.
0x23	[12:0]	X	SCP	XV18TOG3	XV18 Toggle Position 3.
	[25:13]	X		XV18TOG4	XV18 Toggle Position 4.
0x24	[12:0]	X	SCP	XV19TOG1	XV19 Toggle Position 1.
	[25:13]	X		XV19TOG2	XV19 Toggle Position 2.
0x25	[12:0]	X	SCP	XV19TOG3	XV19 Toggle Position 3.
	[25:13]	X		XV19TOG4	XV19 Toggle Position 4.
0x26	[12:0]	X	SCP	XV20TOG1	XV20 Toggle Position 1.
	[25:13]	X		XV20TOG2	XV20 Toggle Position 2.
0x27	[12:0]	X	SCP	XV20TOG3	XV20 Toggle Position 3.
	[25:13]	X		XV20TOG4	XV20 Toggle Position 4.
0x28	[12:0]	X	SCP	XV21TOG1	XV21 Toggle Position 1.
	[25:13]	X		XV21TOG2	XV21 Toggle Position 2.
0x29	[12:0]	X	SCP	XV21TOG3	XV21 Toggle Position 3.
	[25:13]	X		XV21TOG4	XV21 Toggle Position 4.
0x2A	[12:0]	X	SCP	XV22TOG1	XV22 Toggle Position 1.
	[25:13]	X		XV22TOG2	XV22 Toggle Position 2.
0x2B	[12:0]	X	SCP	XV22TOG3	XV22 Toggle Position 3.
	[25:13]	X		XV22TOG4	XV22 Toggle Position 4.
0x2C	[12:0]	X	SCP	XV23TOG1	XV23 Toggle Position 1.
	[25:13]	X		XV23TOG2	XV23 Toggle Position 2.
0x2D	[12:0]	X	SCP	XV23TOG3	XV23 Toggle Position 3.
	[25:13]	X		XV23TOG4	XV23 Toggle Position 4.
0x2E	[12:0]	X	SCP	XV24TOG1	XV24 Toggle Position 1.
	[25:13]	X		XV24TOG2	XV24 Toggle Position 2.
0x2F	[12:0]	X	SCP	XV24TOG3	XV24 Toggle Position 3.
	[25:13]	X		XV24TOG4	XV24 Toggle Position 4.

# AD9920A

**Table 63. V-Sequence (VSEQ) Registers (Default Values Are Undefined)**

Address	Data Bits	Default Value	Update Type	Name	Description
0x00	[0]	X	SCP	CLPOBPOL	CLPOB start polarity.
	[1]	X		PBLKPOL	PBLK start polarity.
	[5:2]	X		HOLD	1 = enable HOLD function for each VPAT group (A, B, C, D).
	[6]	X		VSEQALT_EN	Special V-sequence alternation enable.
	[9:7]	X		SPC_PAT_EN	1 = enable use of special vertical pattern insertion into VPATA sequence. Bit 0: Use VPATB as the special pattern. Bit 1: Use VPATC as the special pattern. Bit 2: Use VPATD as the special pattern.
	[13:10]	X		CONCAT_GRP	Combine multiple VPAT groups together in one sequence. Set register equal to 0x01 to enable.
	[15:14]	X		VREP_MODE	Defines V-alternation repetition mode. 00 = single-pattern alternation for all groups. 01 = two-pattern alternation for all groups. 10 = three-pattern alternation for Group A; Groups B/C/D follow pattern {0, 1, 1, 0, 1, 1...}. 11 = four-pattern alternation for Group A; two-pattern for Groups B/C/D.
	[19:16]	X		LASTREPLEN_EN	Enable a separate pattern length to be used during the last repetition of the V-sequence. One bit for each group (A, B, C, and D); Group A is the LSB. Set bit high to enable. Recommended value is enabled.
0x01	[21:20]	X	SCP	HBLK_MODE	Selection of HBLK modes. 00 = HBLK Mode 0 (normal six-toggle operation). 01 = HBLK Mode 1. 10 = test use only; do not access. 11 = test use only; do not access.
	[23:22]	X		Test	Test use only. Set to 0.
	[24]	X		SUBCK_MASK	1 = enable SUBCK masking feature.
0x01	[13:0]	X	SCP	HDLENE	HD line length for even lines.
0x02	[13:0]	X	SCP	HDLENO	HD line length for odd lines.
0x03	[23:0]	X	SCP	VSGPATSEL	Select which two toggle positions are used by each V-output when they are configured as VSG pulses (in Miscellaneous Register 0x1C). 0 = use Toggle 1, Toggle 2. 1 = use Toggle 3, Toggle 4.
0x04	[12:0]	X	SCP	LASTREPLEN_A	Last repetition length for Group A. Must be enabled using LASTREPLEN_EN register. Set equal to VLENA register.
	[25:13]	X		LASTREPLEN_B	Last repetition length for Group B. Must be enabled using LASTREPLEN_EN register. Set equal to VLENB register.
0x05	[12:0]	X	SCP	LASTREPLEN_C	Last repetition length for Group C. Must be enabled using LASTREPLEN_EN register. Set equal to VLENC register.
	[25:13]	X		LASTREPLEN_D	Last repetition length for Group D. Must be enabled using LASTREPLEN_EN register. Set equal to VLEND register.
0x06	[23:0]	X	SCP	VPOL	Starting polarities for each V-output signal.
0x07	[23:0]	X	SCP	GROUPSEL_0	Select to which group each V1 to V12 signal is assigned. 00 = Group A. 01 = Group B. 10 = Group C. 11 = Group D. Bits[1:0]: V1. Bits[3:2]: V2. Bits[23:22]: V12.

Address	Data Bits	Default Value	Update Type	Name	Description
0x08	[23:0]	X	SCP	GROUPSEL_1	Select to which group each V13 to V24 signal is assigned. 00 = Group A. 01 = Group B. 10 = Group C. 11 = Group D. Bits[1:0]: V13. Bits[3:2]: V14. Bits[23:22]: V24.
0x09	[4:0] [9:5] [14:10] [19:15] [20] [21]	X X X X X X	SCP	VPATSELA VPATSELB VPATSELC VPATSELD SEQ_ALT_INC SEQ_ALT_RST	Selected VPAT group for Group A, from VPAT Group 0 to Group 31. Selected VPAT group for Group B, from VPAT Group 0 to Group 31. Selected VPAT group for Group C, from VPAT Group 0 to Group 31. Selected VPAT group for Group D, from VPAT Group 0 to Group 31. 1 = increment sequence number on next line. 1 = reset sequence number to sequence defined for that particular region in the field register.
0x0A	[12:0] [25:13]	X X	SCP	VSTARTA VLENA	Start position of selected V-pattern Group A. Length of selected V-pattern Group A.
0x0B	[12:0] [25:13]	X X	SCP	VREPA_1 VREPA_2	Number of repetitions for V-pattern Group A for first lines. Number of repetitions for V-pattern Group A for second lines.
0x0C	[12:0] [25:13]	X X	SCP	VREPA_3 VREPA_4	Number of repetitions for V-pattern Group A for third lines. Number of repetitions for V-pattern Group A for fourth lines.
0x0D	[12:0] [25:13]	X X	SCP	VSTARTB VLENB	Start position of selected V-pattern Group B. Length of selected V-pattern Group B.
0x0E	[12:0] [25:13]	X X	SCP	VREPB_ODD VREPB_EVEN	Number of repetitions for V-pattern Group B for odd lines. Number of repetitions for V-pattern Group B for even lines.
0x0F	[12:0] [25:13]	X X	SCP	VSTARTC VLENC	Start position of selected V-pattern Group C. Length of selected V-pattern Group C.
0x10	[12:0] [25:13]	X X	SCP	VREPC_ODD VREPC_EVEN	Number of repetitions for V-pattern Group C for odd lines. Number of repetitions for V-pattern Group C for even lines.
0x11	[12:0] [25:13]	X X	SCP	VSTARTD VLEND	Start position of selected V-pattern Group D. Length of selected V-pattern Group D.
0x12	[12:0] [25:13]	X X	SCP	VREPD_ODD VREPD_EVEN	Number of repetitions for V-pattern Group D for odd lines. Number of repetitions for V-pattern Group D for even lines.
0x13	[12:0] [25:13]	X X	SCP	FREEZE1 RESUME1	Holds the V-outputs at their current levels. Resumes the operation of V-outputs to finish the pattern.
0x14	[12:0] [25:13]	X X	SCP	FREEZE2 RESUME2	Holds the V-outputs at their current levels. Resumes the operation of V-outputs to finish the pattern.
0x15	[12:0] [25:13]	X X	SCP	FREEZE3 RESUME3	Holds the V-outputs at their current levels. Resumes the operation of V-outputs to finish the pattern.
0x16	[12:0] [25:13]	X X	SCP	FREEZE4 RESUME4	Holds the V-outputs at their current levels. Resumes the operation of V-outputs to finish the pattern.
0x17	[12:0] [25:13]	X X	SCP	HBLKSTART HBLKEND	Start location for HBLK in HBLK Mode 0 and HBLK Mode 1. End location for HBLK in HBLK Mode 0 and HBLK Mode 1.
0x18	[12:0] [20:13] [21] [22] [23] [24]	X X X X X X	SCP	HBLKLEN HBLKREP HBLKMASK_H1 HBLKMASK_H2 HBLKMASK_HL HBLKMASK_H3P	HBLK length in HBLK Mode 0 and Mode 1. Number of HBLK repetitions in HBLK Mode 0 and HBLK Mode 1. Masking polarity for H1/H3/H5/H7 during HBLK. Masking polarity for H2/H4/H6/H8 during HBLK. Masking polarity for HL during HBLK. Masking polarity for H3P during 3-phase mode during HBLK.
0x19	[12:0] [25:13]	X X	SCP	HBLKTOGO1 HBLKTOGO2	First HBLK toggle position for odd lines, or RA0H1REPA/B/C in HBLK Mode 1. Second HBLK toggle position for odd lines, or RA1H1REPA/B/C.

# AD9920A

Address	Data Bits	Default Value	Update Type	Name	Description
0x1A	[12:0]	X	SCP	HBLKTOGO3	Third HBLK toggle position for odd lines, or RA2H1REPA/B/C.
	[25:13]	X		HBLKTOGO4	Fourth HBLK toggle position for odd lines, or RA3H1REPA/B/C.
0x1B	[12:0]	X	SCP	HBLKTOGO5	Fifth HBLK toggle position for odd lines, or RA4H1REPA/B/C.
	[25:13]	X		HBLKTOGO6	Sixth HBLK toggle position for odd lines, or RA5H1REPA/B/C.
0x1C	[12:0]	X	SCP	HBLKTOGE1	First HBLK toggle position for even lines, or RA0H2REPA/B/C.
	[25:13]	X		HBLKTOGE2	Second HBLK toggle position for even lines, or RA1H2REPA/B/C.
0x1D	[12:0]	X	SCP	HBLKTOGE3	Third HBLK toggle position for even lines, or RA2H2REPA/B/C.
	[25:13]	X		HBLKTOGE4	Fourth HBLK toggle position for even lines, or RA3H2REPA/B/C.
0x1E	[12:0]	X	SCP	HBLKTOGE5	Fifth HBLK toggle position for even lines, or RA4H2REPA/B/C.
	[25:13]	X		HBLKTOGE6	Sixth HBLK toggle position for even lines, or RA5H2REPA/B/C.
0x1F	[12:0]	X	SCP	HBLKSTARTA	HBLK repeat area Start Position A for HBLK Mode 1. Set to 8191 if not used.
	[25:13]	X		HBLKSTARTB	HBLK repeat area Start Position B for HBLK Mode 1. Set to 8191 if not used.
0x20	[12:0]	X	SCP	HBLKSTARTC	HBLK repeat area Start Position C for HBLK Mode 1. Set to 8191 if not used.
	[16:13]			VMASK_EVEN	1 = enable FREEZE/RESUME for each VPAT group (A, B, C, D); even lines.
	[20:17]			VMASK_ODD	1 = enable FREEZE/RESUME for each VPAT group (A, B, C, D); odd lines.
0x21	[2:0]	X	SCP	HBLKALT_PAT0	HBLK Mode 1, Repeat Area 0 pattern for odd lines.
	[6:4]	X		HBLKALT_PAT1	HBLK Mode 1, Repeat Area 1 pattern for odd lines.
	[10:8]	X		HBLKALT_PAT2	HBLK Mode 1, Repeat Area 2 pattern for odd lines.
	[14:12]	X		HBLKALT_PAT3	HBLK Mode 1, Repeat Area 3 pattern for odd lines.
	[18:16]	X		HBLKALT_PAT4	HBLK Mode 1, Repeat Area 4 pattern for odd lines.
	[22:20]	X		HBLKALT_PAT5	HBLK Mode 1, Repeat Area 5 pattern for odd lines.
0x22	[12:0]	X	SCP	CLPOBTOG1	CLPOB Toggle Position 1.
	[25:13]	X		CLPOBTOG2	CLPOB Toggle Position 2.
0x23	[12:0]	X	SCP	PBLKTOG1	PBLK Toggle Position 1.
	[25:13]	X		PBLKTOG2	PBLK Toggle Position 2.
0x24	[11:0]	X	SCP	HBLK2OFF_A_E	HCLK Offset A for even lines. Used during HBLK Mode 1.
	[23:12]	X		HBLK2OFF_A_O	HCLK Offset A for odd lines. Used during HBLK Mode 1.
0x25	[11:0]	X	SCP	HBLK2OFF_B_E	HCLK Offset B for even lines. Used during HBLK Mode 1.
	[23:12]	X		HBLK2OFF_B_O	HCLK Offset B for odd lines. Used during HBLK Mode 1.
0x26	[11:0]	X	SCP	HBLK2OFF_C_E	HCLK Offset C for even lines. Used during HBLK Mode 1.
	[23:12]	X		HBLK2OFF_C_O	HCLK Offset C for odd lines. Used during HBLK Mode 1.
0x27	[12:0]	X	SCP	HBLKCNT_START	Start position for HBLK counter. For HBLK operation, HBLKCNT_START should be set equal to the value of HBLKSTART; if HBLK interval is not needed, set to 8191.
	[13]			HBLKEND[13]	MSB for HBLKEND register (V-Sequence Register 0x17, Bits[25:13]).

Table 64. Field Registers (Default Values Are Undefined)

Address	Data Bits	Default Value	Update Type	Name	Description
0x00	[4:0]	X	VD	SEQ0	Selected V-sequence for first region in the field.
	[9:5]	X		SEQ1	Selected V-sequence for second region in the field.
	[14:10]	X		SEQ2	Selected V-sequence for third region in the field.
	[19:15]	X		SEQ3	Selected V-sequence for fourth region in the field.
	[24:20]	X		SEQ4	Selected V-sequence for fifth region in the field.
0x01	[4:0]	X	VD	SEQ5	Selected V-sequence for sixth region in the field.
	[9:5]	X		SEQ6	Selected V-sequence for seventh region in the field.
	[14:10]	X		SEQ7	Selected V-sequence for eighth region in the field.
	[19:15]	X		SEQ8	Selected V-sequence for ninth region in the field.
	[21:20]			MULT_SWEEP0	Enables multiplier mode and/or sweep mode for Region 0. 0 = multiplier off/sweep off. 1 = multiplier off/sweep on. 2 = multiplier on/sweep off. 3 = multiplier on/sweep on.
	[23:22] [25:24]			MULT_SWEEP1 MULT_SWEEP2	Enables multiplier mode and/or sweep mode for Region 1. Enables multiplier mode and/or sweep mode for Region 2.
0x02	[12:0]	X	VD	HDLASTLEN	HD last line length. Line length of last line in the field.
	[14:13]	X		MULT_SWEEP3	Enables multiplier mode and/or sweep mode for Region 3.
	[16:15]	X		MULT_SWEEP4	Enables multiplier mode and/or sweep mode for Region 4.
	[18:17]	X		MULT_SWEEP5	Enables multiplier mode and/or sweep mode for Region 5.
	[20:19]	X		MULT_SWEEP6	Enables multiplier mode and/or sweep mode for Region 6.
	[22:21]	X		MULT_SWEEP7	Enables multiplier mode and/or sweep mode for Region 7.
	[24:23]	X		MULT_SWEEP8	Enables multiplier mode and/or sweep mode for Region 8.
	[25]	X		HDLASTLEN_13	HD last line length bit [13] when 14-bit H-counter is enabled.
	0x03	[12:0]		X	VD
[25:13]		X	SCP1	V-Sequence Change Position 1.	
0x04	[12:0]	X	VD	SCP2	V-Sequence Change Position 2.
	[25:13]	X		SCP3	V-Sequence Change Position 3.
0x05	[12:0]	X	VD	SCP4	V-Sequence Change Position 4.
	[25:13]	X		SCP5	V-Sequence Change Position 5.
0x06	[12:0]	X	VD	SCP6	V-Sequence Change Position 6.
	[25:13]	X		SCP7	V-Sequence Change Position 7.
0x07	[12:0]	X	VD	SCP8	V-Sequence Change Position 8.
	[25:13]	X		VDLEN	VD field length (number of lines in the field).
0x08	[12:0]	X	VD	SGACTLINE1	SG Active Line 1.
	[25:13]	X		SGACTLINE2	SG Active Line 2. Set to SG Active Line 1 or maximum if not used.
0x09	[23:0]	X	VD	SGMASK	Masking of VSG outputs during SG active line.
0x0A	[12:0]	X	VD	CLPMASKSTART1	CLPOB Mask Region 1 start position. Set to 8191 to disable.
	[25:13]	X		CLPMASKEND1	CLPOB Mask Region 1 end position. Set to 0 to disable.
0x0B	[12:0]	X	VD	CLPMASKSTART2	CLPOB Mask Region 2 start position. Set to 8191 to disable.
	[25:13]	X		CLPMASKEND2	CLPOB Mask Region 2 end position. Set to 0 to disable.
0x0C	[12:0]	X	VD	CLPMASKSTART3	CLPOB Mask Region 3 start position. Set to 8191 to disable.
	[25:13]	X		CLPMASKEND3	CLPOB Mask Region 3 end position. Set to 0 to disable.
0x0D	[12:0]	X	VD	PBLKMASKSTART1	PBLK Mask Region 1 start position. Set to 8191 to disable.
	[25:13]	X		PBLKMASKEND1	PBLK Mask Region 1 end position. Set to 0 to disable.
0x0E	[12:0]	X	VD	PBLKMASKSTART2	PBLK Mask Region 2 start position. Set to 8191 to disable.
	[25:13]	X		PBLKMASKEND2	PBLK Mask Region 2 end position. Set to 0 to disable.
0x0F	[12:0]	X	VD	PBLKMASKSTART3	PBLK Mask Region 3 start position. Set to 8191 to disable.
	[25:13]	X		PBLKMASKEND3	PBLK Mask Region 3 end position. Set to 0 to disable.

# AD9920A

## OUTLINE DIMENSIONS

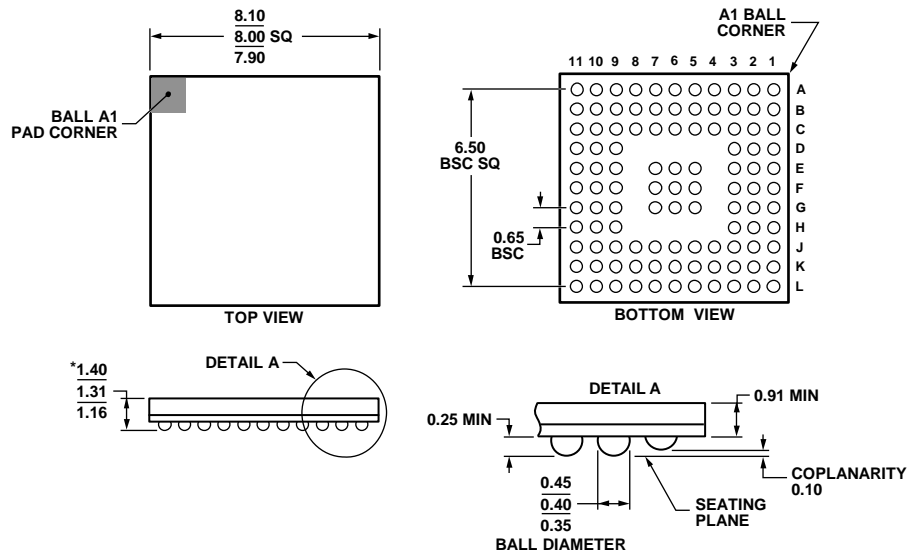

\*COMPLIANT TO JEDEC STANDARDS MO-225  
WITH THE EXCEPTION TO PACKAGE HEIGHT.

Figure 118. 105-Ball Chip Scale Package Ball Grid Array [CSP\_BGA]  
(BC-105-1)

Dimensions shown in millimeters

080807-A

## ORDERING GUIDE

Model <sup>1</sup>	Temperature Range	Package Description	Package Option
AD9920ABBCZ	-25°C to +85°C	105-Ball CSP_BGA	BC-105-1
AD9920ABBCZRL	-25°C to +85°C	105-Ball CSP_BGA	BC-105-1

<sup>1</sup> Z = RoHS Compliant Part.

## Looking for pricing, stock, or lifecycle information?

Click below to explore more details on WIN SOURCE:

 [View AD9920ABBCZ on WIN SOURCE](#)

 [Analog Devices Inc. Information](#)

## Optimize Your Supply Chain with WIN SOURCE Solutions

-  Global Sourcing Solution
-  Obsolete Management
-  Cost Control Management
-  Shortage Management
-  Alternative Solution
-  Excess Inventory Management