





THE DATASHEET OF SD103AW



SPECIFICATION SHEET

SPECIFICATION SHEET NO.	P115- SOD123103AWSS4
DATE	Jan. 15, 2022
REVISION	A0
DESCRIPTION	SMD Schottky Diodes, SOD-123 series, 2 pads SD103AW Type, Reverse Voltage 40V Max. Forward Current 350mA Max. Operating Temp. Range -55°C ~+150°C, Package in Tape/Reel, 3000pcs/Reel RoHS/RoHS III compliant
CUSTOMER	
CUSTOMER PART NUMBER	
CROSS REF. PART NUMBER	
ORIGINAL PART NUMBER	MDD SD103AW
PART CODE	SOD123103AWSS4

VENDOR APPROVE			
Issued/Checked/Approved			
DATE: Jan. 15, 2022			

CUSTOMER APPROVE	
DATE:	

1/16/2022

SMD SCHOTTKY DIODES SOD123 SERIES



MAIN FEATURE

- Fast Switching Speed
- Guard Ring Construction For Transient Protection
- Negligible Reverse Recovery Time
- Low Reverse Capacitance

APPLICATION

- For printed circuit board

PART CODE GUIDE

RFQ

[Request For Quotation](#)

SOD123	103AW	S	S4
1	2	3	4

- 1) **SOD123**: SMD Small Signal Schottky diodes, 2 pads, SOD-123 series code
- 2) **103AW**: Type code for original part number SD103AW
- 3) **S**: Package code, Tape/reel, 3000pcs/reel.
- 4) **S4**: Marking code for "S4" on the case surface, Different Marking for different specification.

SMD SCHOTTKY DIODES SOD123 SERIES

DIMENSION (Unit: Inch/mm)

Image for reference



Marking: S4

SOD-123

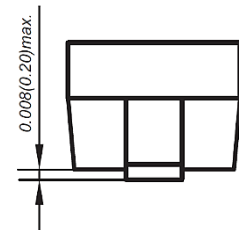
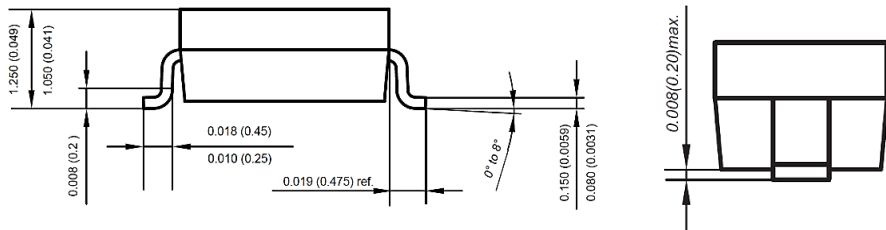
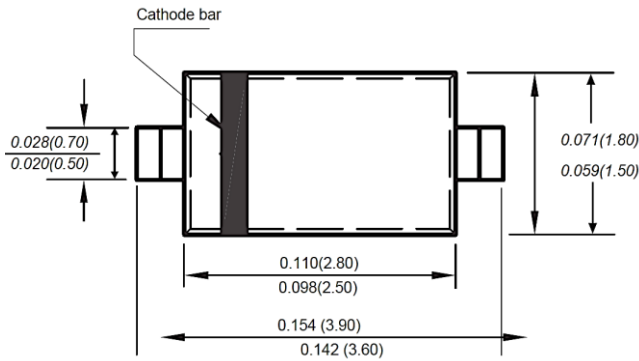

Recommend Pad Layout

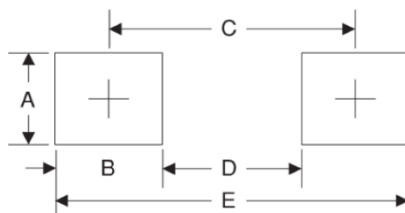

Symbol I	Unit (inch)	Unit (mm)
A	0.047	1.20
B	0.047	1.20
C	0.126	3.20
D	0.079	2.00
E	0.173	4.40

SMD SCHOTTKY DIODES SOD123 SERIES
MECHANICAL DATA

Case	Terminals	Polarity	Weight per piece
JEDEC SOD-123 molded plastic body	Solder plated, Solderable per MIL-STD-750, Method 2026	Polarity symbol marking on case	0.0007 Ounce, 0.021 grams

ABSOLUTE MAX. RATING AT 25 °C

Parameter	SYMBOLS	VALUE			UNITS
		Min.	Typical	Max.	
Repetitive peak reverse voltage	V _{RRM}			40	Volts
Working peak reverse voltage	V _{RWM}			40	Volts
DC Blocking voltage	V _{DC}			40	Volts
RMS voltage	V _{R(RMS)}			28	Volts
Forward continuous current	I _{FM}			350	mA
Repetitive peak forward current @t 1.0s	I _{FRM}			1.50	A
Power Dissipation	P _d			400	mW
Thermal resistance junction to ambient	R _{θJA}			300	°C/W
Operating Junction temperature range	T _J	-55		+150	°C
Storage temperature range	T _{STG}	-55		+150	°C

SMD SCHOTTKY DIODES SOD123 SERIES

CHARACTERISTICS AT Ta= 25 °C

Parameter	SYMBOLS	VALUE			UNIT	Condition
		Min.	Typ.	Max.		
Reverse breakdown Voltage Reverse	V (BR)R	40			V	I _R = 100 μA
Forward voltage	V _F			0.37	V	I _F = 20mA
				0.60	V	I _F = 200mA
Reverse current	I _{RM}			5.0	μA	V _R = 30 V
Capacitance between terminals	C _T		28		pF	V _R = 0V, f = 1.0MHz
Reverse recovery time	t _{rr}		10		ns	I _F =I _R =200mA I _{rr} =0.1 * I _R , R _L =100 Ω

SMD SCHOTTKY DIODES SOD123 SERIES
RELIABILITY

Number	Experiment Items	Experiment Method And Conditions	Reference Documents
1	Solder Resistance Test	Test 260°C± 5°C for 10 ± 2 sec. Immerse body into solder 1/16" ± 1/32"	MIL-STD-750D METHOD-2031.2
2	Solderability Test	230°C ±5°C for 5 sec.	MIL-STD-750D METHOD-2026.1 0
3	Pull Test	1 kg in axial lead direction for 10 sec.	MIL-STD-750D METHOD-2036.4
4	Bend Test	0.5Kg Weight Applied To Each Lead, Bending Arcs 90 °C ± 5 °C For 3 Times	MIL-STD-750D METHOD-2036.4
5	High Temperature Reverse Bias Test	TA=100°C for 1000 Hours at VR=80% Rated VR	MIL-STD-750D METHOD-1038.4
6	Forward Operation Life Test	TA=25°C Rated Average Rectified Current	MIL-STD-750D METHOD-1027.3
7	Intermittent Operation Life Test	On state: 5 min with rated IRMS Power Off state: 5 min with Cool Forced Air. On and off for 1000 cycles.	MIL-STD-750D METHOD-1036.3
8	Pressure Cooker Test	15 PSIG, TA=121°C, 4 hours	MIL-S-19500 APPENOIXC
9	Temperature Cycling Test	-55°C~+125°C; 30 Minutes For Dwelled Time 5 minutes for transferred time. Total: 10 cycles.	MIL-STD-750D METHOD-1051.7
10	Thermal Shock Test	0°C for 5 minutes., 100°C for 5minutes, Total: 10 cycles	MIL-STD-750D METHOD-1056.7
11	Forward Surge Test	8.3ms Single Sale Sine-wave One Surge.	MIL-STD-750D METHOD-4066.4
12	Humidity Test	TA=65°C, RH=98% for 1000 hours.	MIL-STD-750D METHOD-1021.3
13	High Temperature Storage life Test	150°C for 1000 Hours	MIL-STD-750D METHOD-1031.5

SMD SCHOTTKY DIODES SOD123 SERIES

SUGGESTED REFLOW PROFILE (For Reference Only)

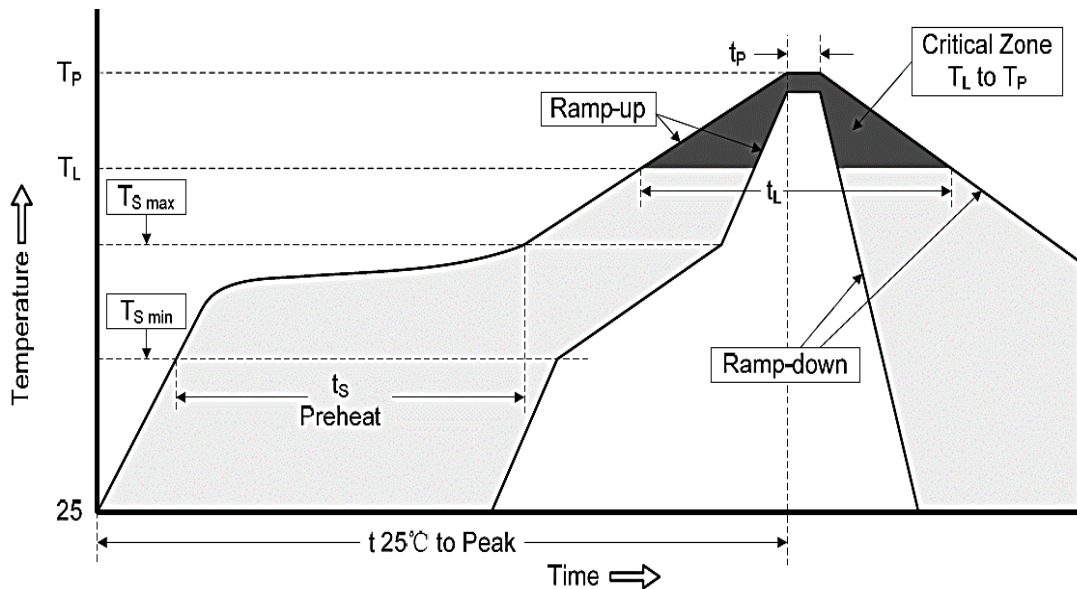

Profile Feature		Pb-Free Assembly
Average Ramp-up Rate (Ts Max to Tp)		3°C/second Max
Preheat	Temperature Min (Ts Min.)	150°C
	Temperature Max (Ts Max.)	200°C
	Time (ts Min. to ts Max.)	60 ~ 180 seconds
Time maintained above	Temperature (Tl)	217°C
	Time (tl)	60 ~ 150 seconds
Peak/Classification Temperature (Tp)		260 °C
Time within 5°C of actual Peak Temperature (tp)		10 seconds
Ramp-down rate		6 °C /Second Max.
Time 25 °C to Peak Temperature		6 minutes Max.
Suggest reflow times		3 Times Max.

SMD SCHOTTKY DIODES SOD123 SERIES

RATINGS AND CHARACTERISTIC CURVES (For Reference Only)

Fig.1 Power Derating Curve

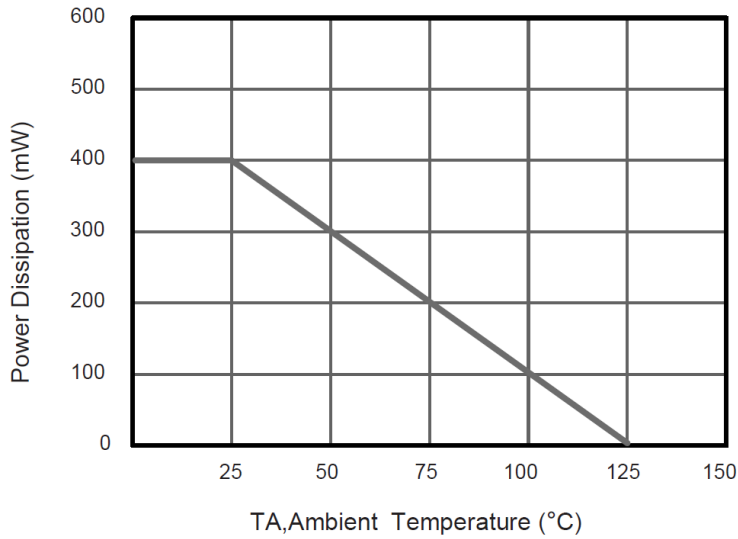
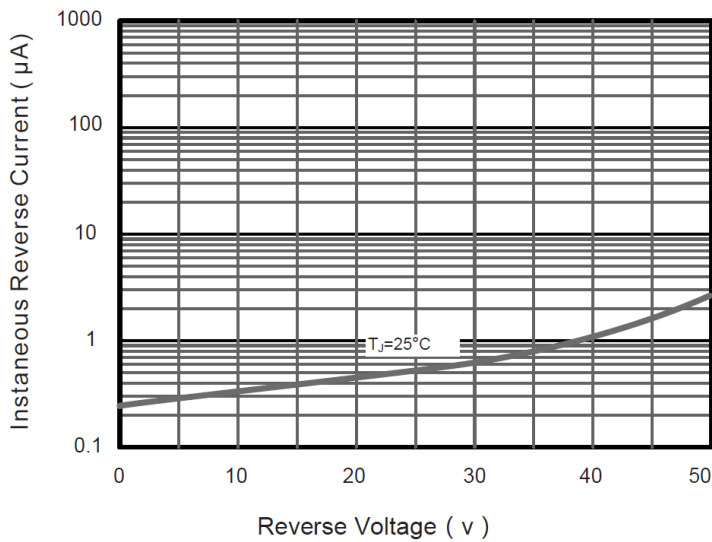

Fig.2 Typical Reverse Characteristics



SMD SCHOTTKY DIODES SOD123 SERIES

RATINGS AND CHARACTERISTIC CURVES (For Reference Only)

Fig.3 Forward Characteristics

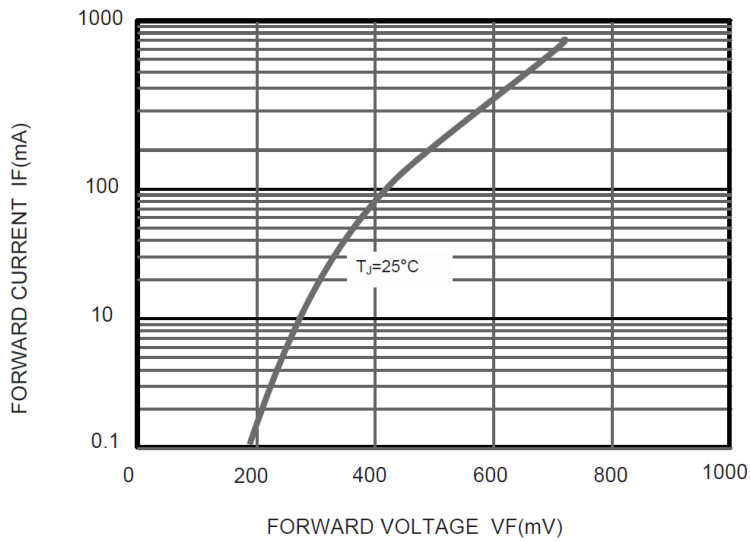
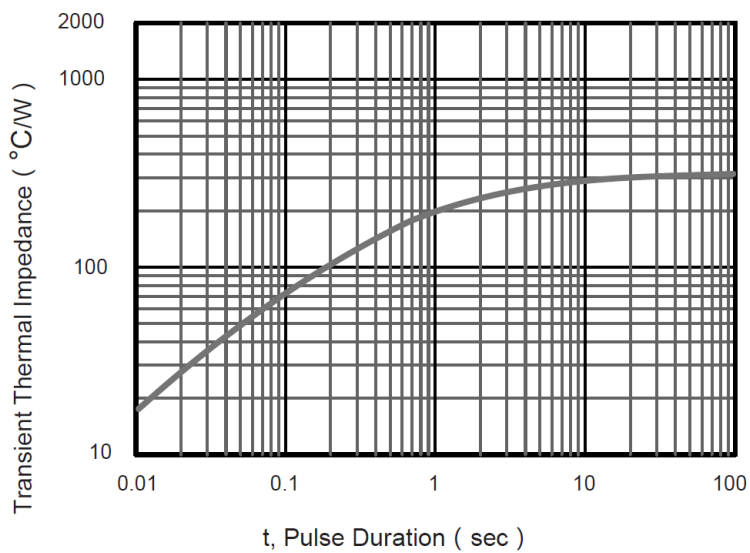

Fig.4 Typical Transient Thermal Impedance



SMD SCHOTTKY DIODES SOD123 SERIES

RATINGS AND CHARACTERISTIC CURVES (For Reference Only)

Fig.5 Typical Junction Capacitance

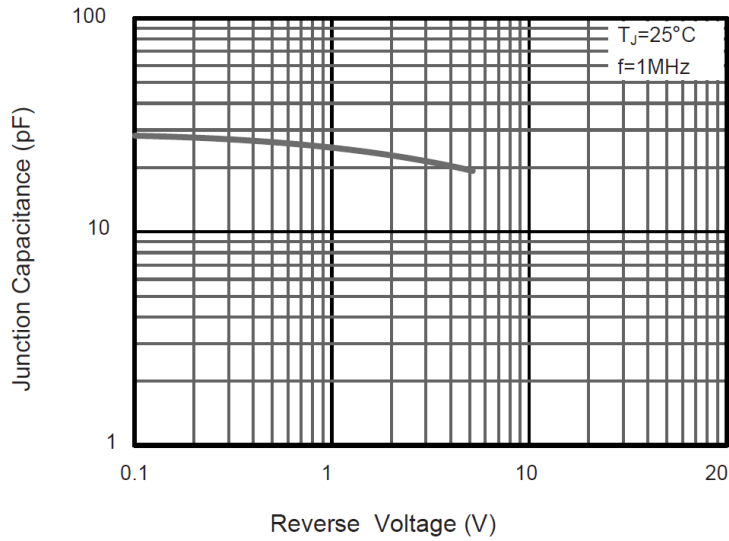

SMD SCHOTTKY DIODES SOD123 SERIES

TAPE/REEL (Unit: mm)

All Devices are packed in accordance with EIA standard RS-481-A and specifications.

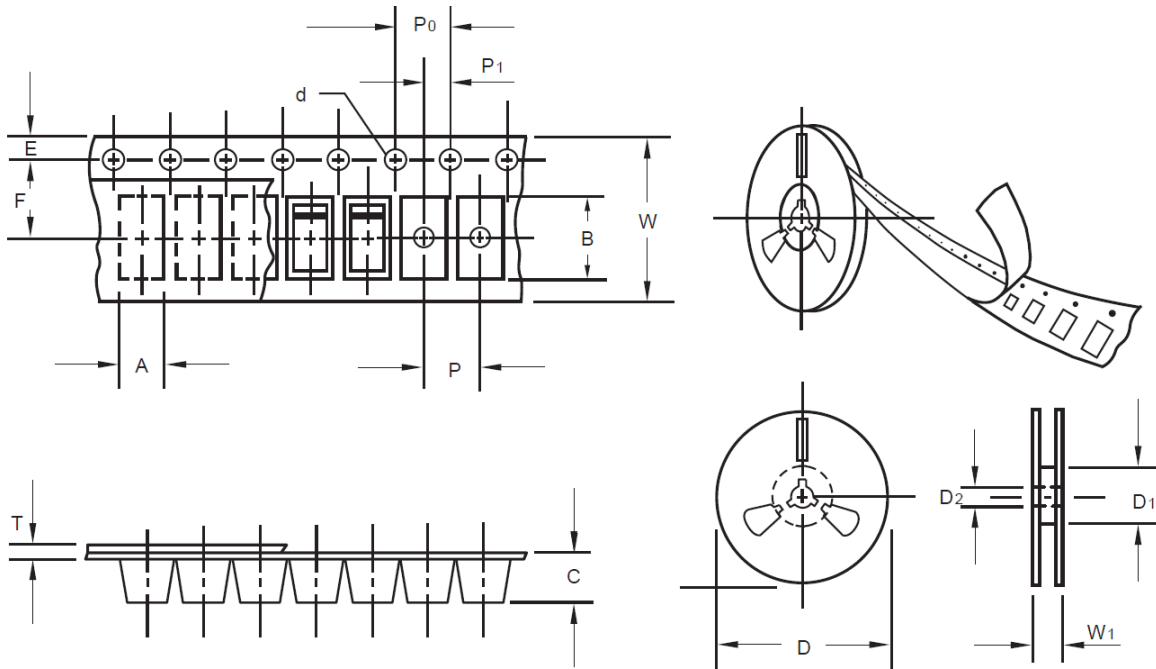

Item	Symbol	Tolerance	SO-123
Carrier width	A	0.1	2.10
Carrier Length	B	0.1	4.00
Carrier Depth	C	0.1	1.60
Sprocket hole	d	0.05	1.55
13" Reel outside diameter	-	-	-
13" Reel inner diameter	-	-	-
7" Reel outside diameter	D	2.0	178.00
7" Reel inner diameter	D1	Min.	50.00
Feed hole diameter	D2	0.5	13.00
Sprocket hole position	E	0.1	1.75
Punch hole position	F	0.1	3.50
Punch hole pitch	P	0.1	4.00
Sprocket hole pitch	P0	0.1	4.00
Embossment center	P1	0.1	2.00
Overall tape thickness	T	0.1	0.25
Tape width	W	0.3	8.15
Reel width	W1	1.0	10.50

SMD SCHOTTKY DIODES SOD123 SERIES

PACKAGE

Case Code	SOD-123
Reel Size	7"
Reel Size	178 mm
MPQ/Reel	3000 pcs
Qty. /Box	6000 pcs
G.W/Box	2 lbs

DISCLAIMER

NextGen Component, Inc. reserves the right to make changes to the product(s) and or information contained herein without notice. No liability is assumed as a result of their use or application. No rights under any patent accompany the sale of any such product(s) or information







Looking for pricing, stock, or lifecycle information?

Click below to explore more details on WIN SOURCE:

 [View SD103AW on WIN SOURCE](#)

 [MDD Information](#)

Optimize Your Supply Chain with WIN SOURCE Solutions

-  Global Sourcing Solution
-  Obsolete Management
-  Cost Control Management
-  Shortage Management
-  Alternative Solution
-  Excess Inventory Management