



**THE DATASHEET OF
MAX13253ATB+T**



Click [here](#) for production status of specific part numbers.

MAX13253

1A, Spread-Spectrum, Push-Pull, Transformer Driver for Isolated Power Supplies

General Description

The MAX13253 is a 1A, push-pull, transformer driver designed to provide a simple solution for low-EMI isolated power supplies. The MAX13253 has an internal oscillator and operates from a single +3.0V to +5.5V supply. The transformer's secondary-to-primary winding ratio defines the output voltage, allowing selection of virtually any isolated output voltage with galvanic isolation.

The MAX13253 features an integrated oscillator driving a pair of n-channel power switches. The driver includes pin-selectable spread-spectrum oscillation and a well-controlled slew rate to reduce EMI. The MAX13253 can optionally be driven by an external clock to further manage EMI. Internal circuitry guarantees a fixed 50% duty cycle to prevent DC current flow through the transformer, regardless of which clock source is used.

The MAX13253 operates with up to 1A of continuous current and features integrated protection including fault detection, overcurrent protection, and thermal shutdown.

The MAX13253 includes a low-current shutdown mode to reduce the overall supply current to less than 5 μ A (max) when the driver is disabled.

The MAX13253 is available in a small 10-pin (3mm x 3mm) TDFN package and is specified over the -40°C to +125°C temperature range.

Features and Benefits

- Simple, Flexible Design
 - +3.0V to +5.5V Supply Range
 - Low RON 300m Ω (max) at 4.5V
 - Up to 90% Efficiency
 - Provides Up to 1A to the Transformer
 - Internal or External Clock Source
 - Internal Oscillator Frequency: 250kHz or 600kHz
 - Optional Spread-Spectrum Oscillation
 - -40°C to +125°C Temperature Range
- Integrated System Protection
 - Fault Detection and Indication
 - Overcurrent Limiting
 - Undervoltage Lockout
 - Thermal Shutdown
- Saves Space on Board
 - Small 10-Pin TDFN Package (3mm x 3mm)

Applications

- Power Meter Data Interface
- Isolated Fieldbus Interface
- Medical Equipment
- Isolated Analog Front-End
- Isolated USB Power

Ordering Information appears at end of data sheet.

Typical Operating Circuit

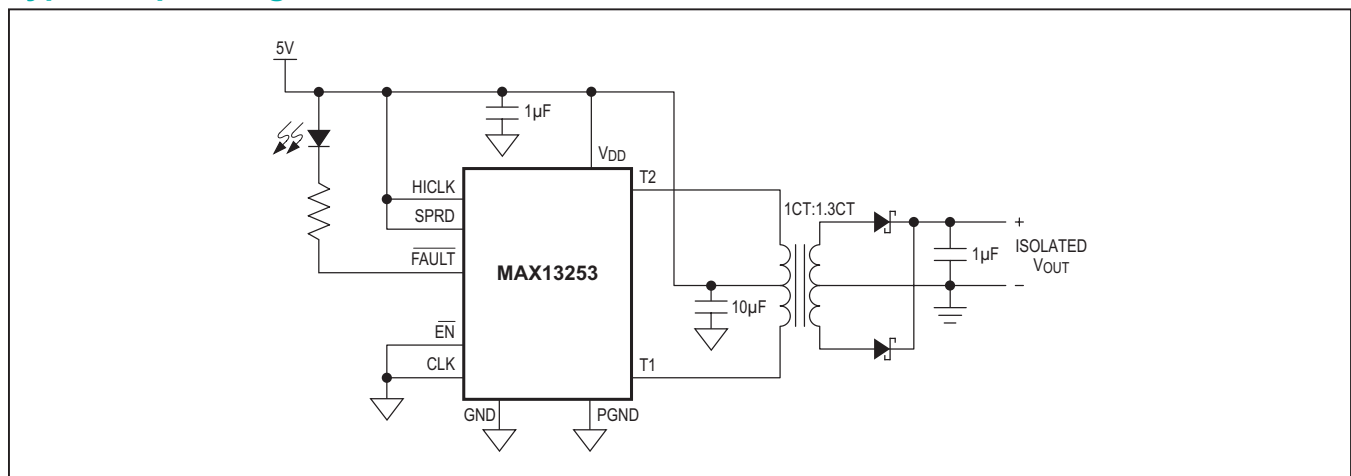

Absolute Maximum Ratings

(All voltages referenced to GND.)

V _{DD} , FAULT, CLK, HICLK, SPRD, EN	-0.3V to +6V
T1, T2	-0.3V to +16.5V
T1, T2 Maximum Continuous Current	+1.75A
FAULT Maximum Continuous Current	+50mA
Continuous Power Dissipation (T _A = +70°C)	
TDFN (Multilayer Board)	
(derate 24.4mW/°C above +70°C)	1951.2mW

TDFN (Single-Layer Board)	
(derate 18.5mW/°C above +70°C)	1481.5mW
Operating Temperature Range	-40°C to +125°C
Junction Temperature	+150°C
Storage Temperature Range	-65°C to +150°C
Lead Temperature (soldering, 10s)	+300°C
Soldering Temperature (reflow)	+260°C

Stresses beyond those listed under "Absolute Maximum Ratings" may cause permanent damage to the device. These are stress ratings only, and functional operation of the device at these or any other conditions beyond those indicated in the operational sections of the specifications is not implied. Exposure to absolute maximum rating conditions for extended periods may affect device reliability.

Package Information

PACKAGE TYPE: 10 TDFN	
Package Code	T1033+1
Outline Number	21-0137
Land Pattern Number	90-0003
THERMAL RESISTANCE, SINGLE-LAYER BOARD	
Junction to Ambient (θ _{JA})	54°C/W
Junction to Case (θ _{JC})	9°C/W
THERMAL RESISTANCE, MULTILAYER BOARD	
Junction to Ambient (θ _{JA})	41°C/W
Junction to Case (θ _{JC})	9°C/W

For the latest package outline information and land patterns (footprints), go to www.maximintegrated.com/packages. Note that a "+", "#", or "-" in the package code indicates RoHS status only. Package drawings may show a different suffix character, but the drawing pertains to the package regardless of RoHS status.

Package thermal resistances were obtained using the method described in JEDEC specification JESD51-7, using a four-layer board. For detailed information on package thermal considerations, refer to www.maximintegrated.com/thermal-tutorial.

Electrical Characteristics

(V_{DD} = +3.0V to +5.5V, T_A = T_{MIN} to T_{MAX}, unless otherwise noted. Typical values are at V_{DD} = +5.0V and T_A = +25°C.) (Note 1)

PARAMETER	SYMBOL	CONDITIONS	MIN	TYP	MAX	UNITS
DC CHARACTERISTICS						
Supply Voltage Range	V _{DD}		3.0		5.5	V
Supply Current	I _{DD}	V _{EN} = 0V, V _{CLK} = 0V, V _{SPRD} = 0V, T1 and T2 not connected		1.1	1.8	mA
		V _{HICLK} = 0V				
				2.1	3.5	
Disable Supply Current	I _{DIS}	V _{EN} = V _{DD} , T1, T2, CLK, SPRD, HICLK connected to GND or V _{DD} (Note 2)			5	µA
Driver Output Resistance	R _O	I _{OUT} = 500mA	V _{DD} = 3.0V	160	350	mΩ
			V _{DD} = 4.5V	145	300	

Electrical Characteristics (continued)

(V_{DD} = +3.0V to +5.5V, T_A = T_{MIN} to T_{MAX}, unless otherwise noted. Typical values are at V_{DD} = +5.0V and T_A = +25°C.) (Note 1)

PARAMETER	SYMBOL	CONDITIONS	MIN	TYP	MAX	UNITS	
Undervoltage Lockout Threshold	V _{UVLO}	V _{DD} rising	2.6	2.75	2.9	V	
Undervoltage Lockout Threshold Hysteresis	V _{UVLO_HYST}			250		mV	
T1, T2 Current Limit	I _{LIM}	3.0V < V _{DD} < 3.6V	1.1	1.3	1.5	A	
		4.5V < V _{DD} < 5.5V	1.2	1.4	1.6		
T1, T2 Leakage Current	I _{LKG}	V _{EN} = V _{DD} , V _{CLK} = 0V; T1, T2 = 0V or V _{DD}	-1		+1	μA	
LOGIC SIGNALS (CLK, EN, HICLK, SPRD, FAULT)							
Input Logic-High Voltage	V _{IH}		2			V	
Input Logic-Low Voltage	V _{IL}				0.8	V	
Input Leakage Current	I _{IL}	EN, CLK, SPRD, HICLK = 0V or 5.5V	-1		+1	μA	
SPRD Pulldown Current	I _{PD}	V _{SPRD} = V _{DD}	5	10	20	μA	
FAULT Output Logic-Low Voltage	V _{OL}	I _{SINK} = 10mA			0.4	V	
FAULT Leakage Current	I _{LKGF}	V _{FAULT} = 5.5V, FAULT deasserted			1	μA	
AC CHARACTERISTICS							
Switching Frequency	f _{SW}	Figure 2, V _{CLK} = 0V, V _{SPRD} = 0V	V _{HICLK} = 0V	237	250	263	kHz
			V _{HICLK} = V _{DD}	564	600	636	
Frequency Spread	Δf _{SW}	Figure 1, V _{SPRD} = V _{DD}		±4		%	
Spread Modulation Rate	f _{MOD}	Figure 1, V _{SPRD} = V _{DD}	V _{HICLK} = 0V	f _{SW} /12		kHz	
			V _{HICLK} = V _{DD}	f _{SW} /28			
CLK Input Frequency	f _{EXT}		200		2000	kHz	
CLK to T1, T2 Propagation Delay	t _{PD}	T1/T2 switching low		230		ns	
T1, T2 Duty Cycle	D	Internal or external clocking		50		%	
T1, T2 Slew Rate	t _{SLEW}	Figure 2		200		V/μs	
Crossover Dead Time	t _{DEAD}	Figure 2		50		ns	
Watchdog Timeout	t _{WDOG}		20	35	55	μs	
PROTECTION							
Thermal-Shutdown Threshold	T _{SHDN}			+160		°C	
Thermal-Shutdown Hysteresis	T _{SHDN_HYS}			30		°C	

Note 1: All units are 100% production tested at T_A = +25°C. Specifications over temperature are guaranteed by design.**Note 2:** Disable supply current includes output switch-leakage currents.

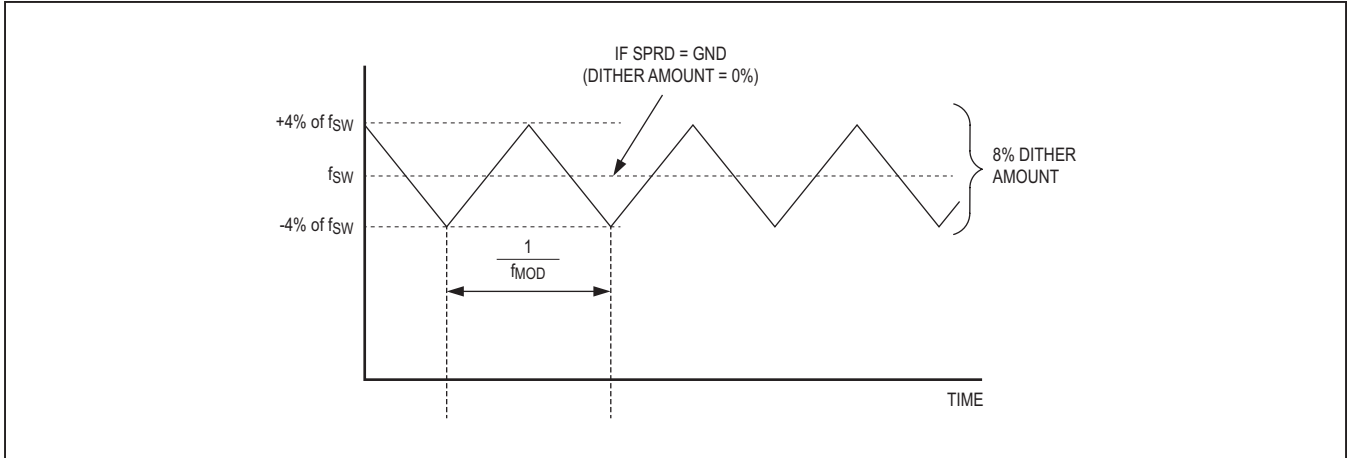

Figure 1. Frequency Spread Timing Diagram

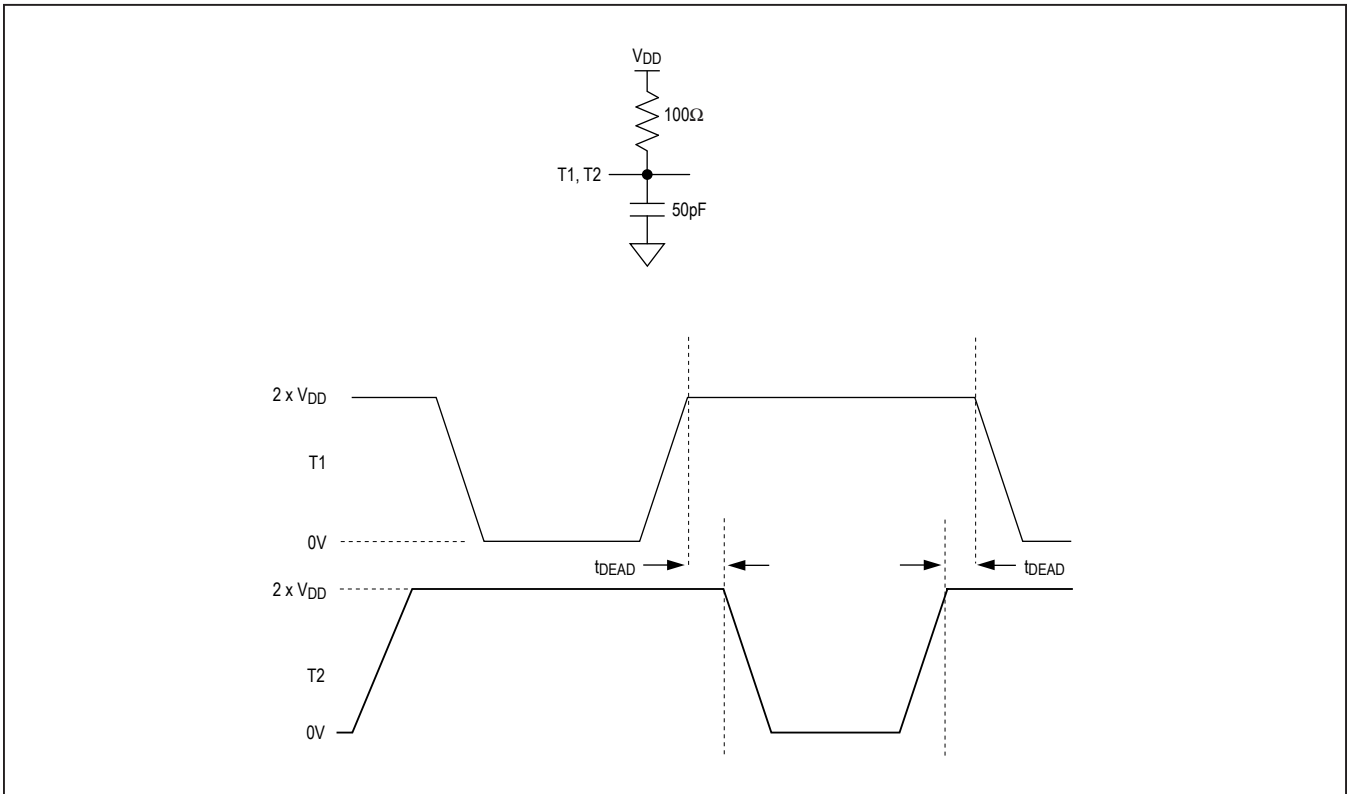
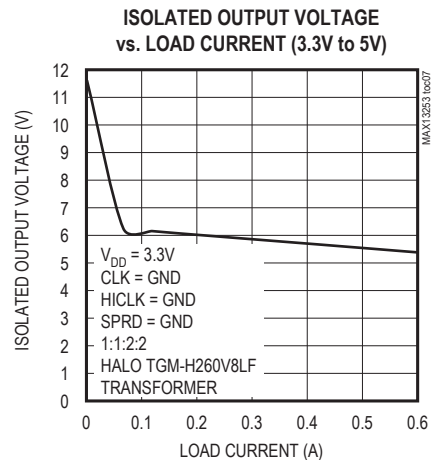
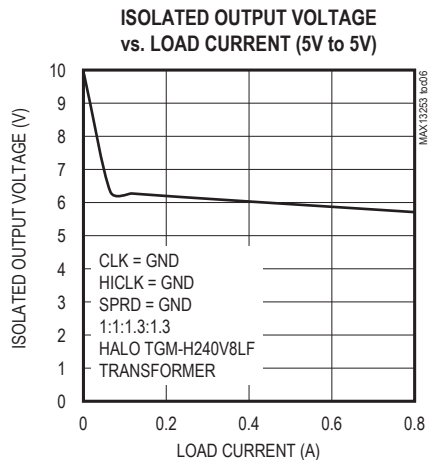
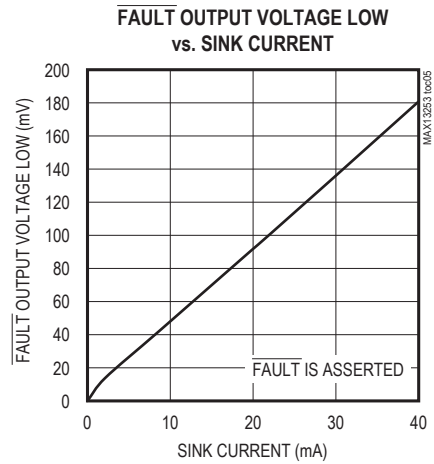
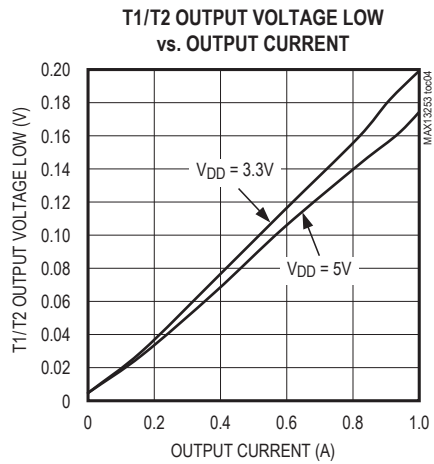
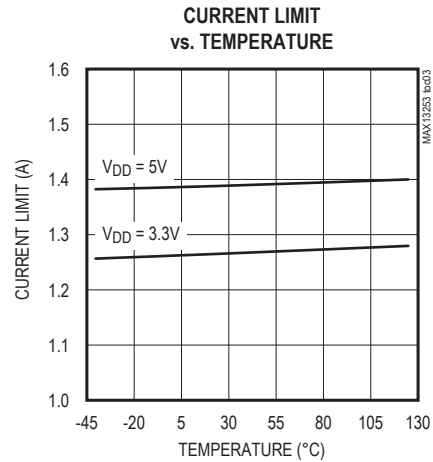
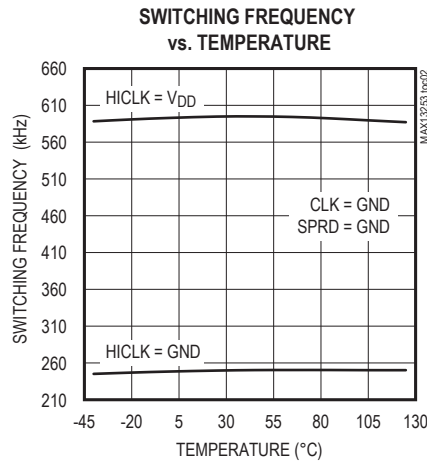
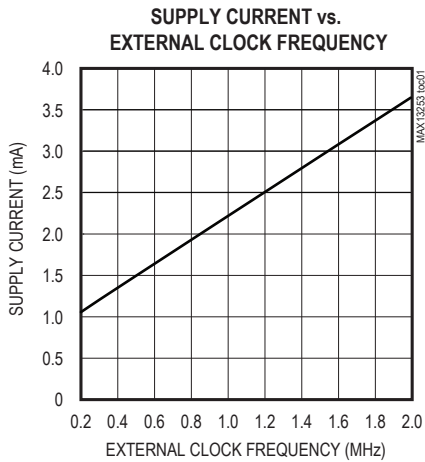

Figure 2. T1, T2 Timing Diagram

Typical Operating Characteristics

($V_{DD} = +5V$, $T_A = +25^\circ C$, unless otherwise noted.)



Typical Operating Characteristics (continued)

($V_{DD} = +5V$, $T_A = +25^\circ C$, unless otherwise noted.)

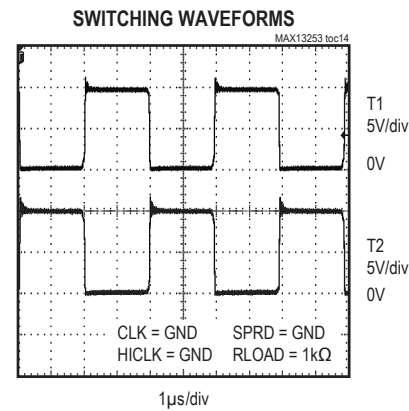
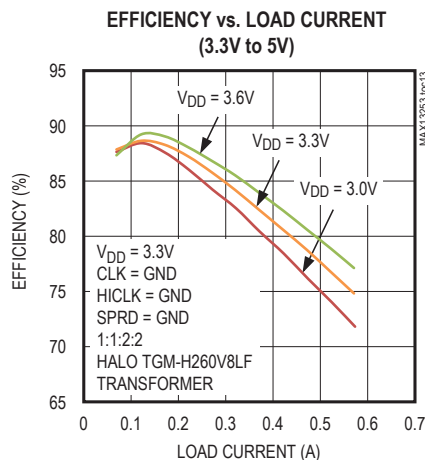
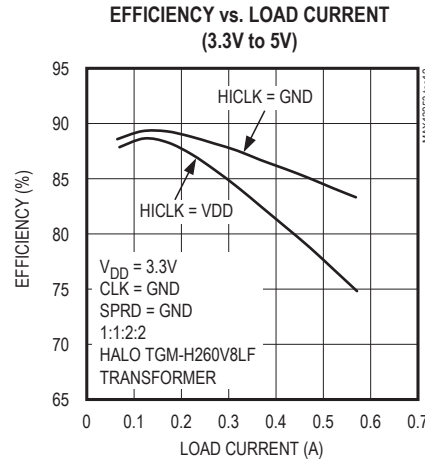
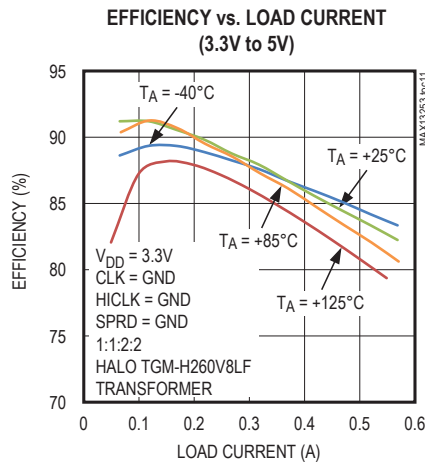
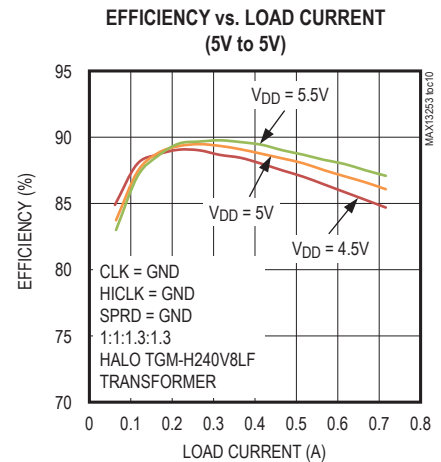
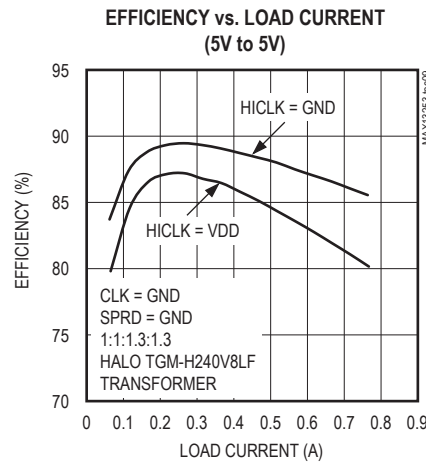
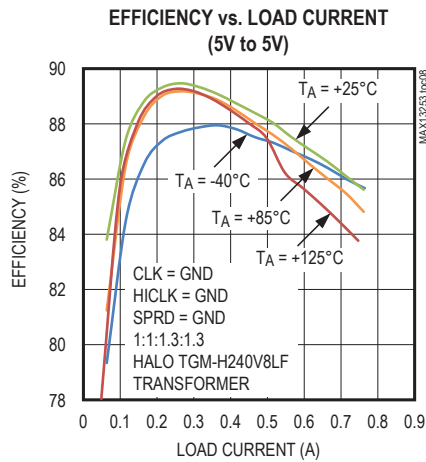

Pin Configuration

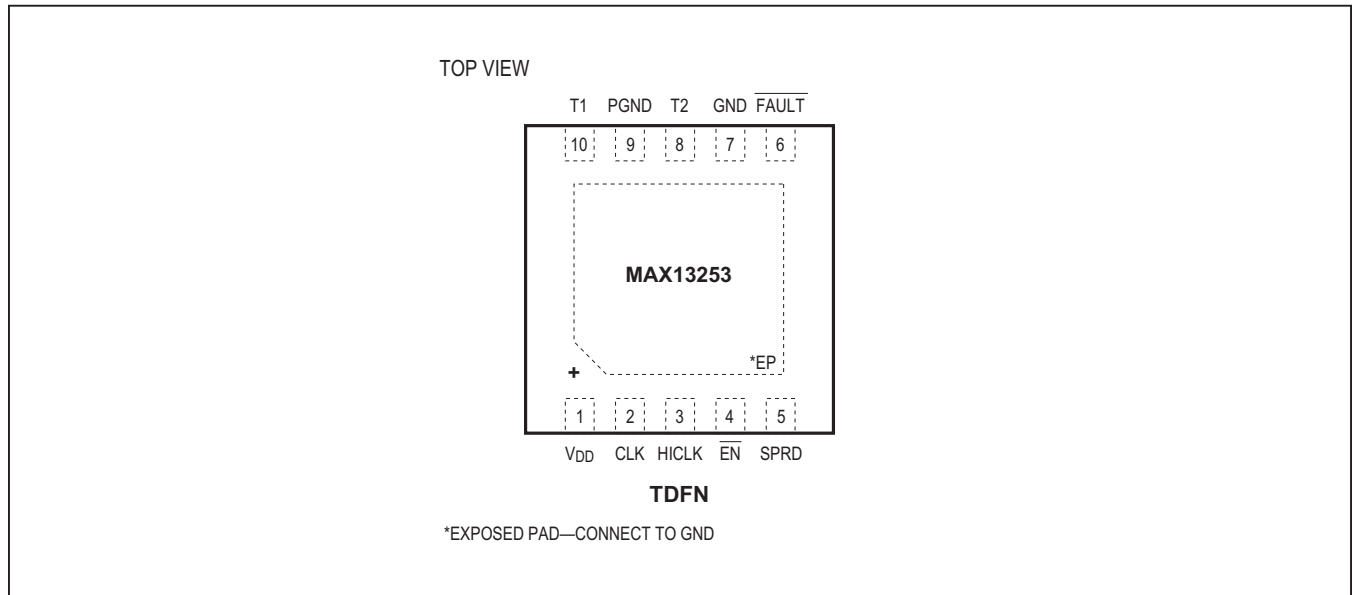

Pin Description

PIN	NAME	FUNCTION
1	V _{DD}	Power-Supply Input. Bypass V _{DD} to GND with a 1µF capacitor as close as possible to the device.
2	CLK	Clock Input. Connect CLK to GND to enable internal clocking. Apply a clock signal to CLK to enable external clocking.
3	HICLK	Internal Oscillator Frequency Select Input. Drive HICLK high to set the internal oscillator to a 600kHz switching frequency. Drive HICLK low to set the internal oscillator to a 250kHz switching frequency.
4	$\overline{\text{EN}}$	Active-Low Enable Input. Drive $\overline{\text{EN}}$ low to enable the device. Drive $\overline{\text{EN}}$ high to disable the device.
5	SPRD	Spread-Spectrum Enable Input. Drive SPRD high to enable ±4% spread spectrum on the internal oscillator. Drive SPRD low or leave it unconnected to disable spread spectrum. SPRD does not have any effect when an external clock is used.
6	$\overline{\text{FAULT}}$	Active-Low Fault Open-Drain Output. The $\overline{\text{FAULT}}$ open-drain transistor turns on when an overcurrent or overtemperature condition occurs.
7	GND	Logic and Analog Ground
8	T2	Transformer Drive Output 2
9	PGND	Power Ground. The transformer primary current flows through PGND. Ensure a low-resistance connection to ground.
10	T1	Transformer Drive Output 1
—	EP	Exposed Pad. Internally connected to GND. Connect EP to a large ground plane to maximize thermal performance; not intended as an electrical connection point.

Functional Diagram

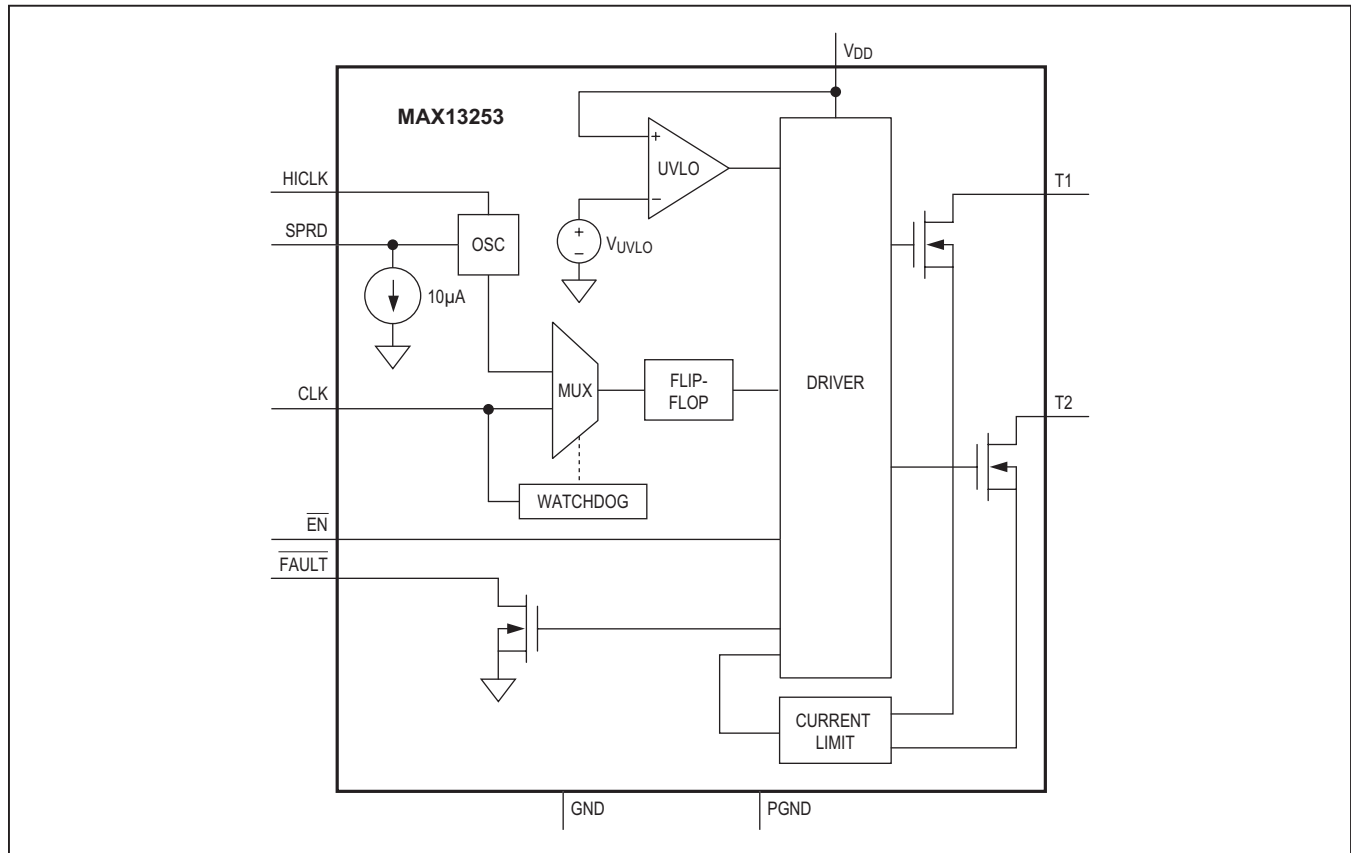

Detailed Description

The MAX13253 is an integrated primary-side transformer driver for low-EMI isolated power-supply circuits. An on-board oscillator, protection circuitry, and internal MOSFETs provide up to 1A of drive current to the primary windings of a center-tapped transformer. The MAX13253 features an internal oscillator for autonomous operation and an external clock source input to synchronize multiple MAX13253 devices. Regardless of the clock source used, an internal flip-flop stage guarantees a fixed 50% duty cycle to prevent DC current flow in the transformer.

The MAX13253 operates from a single +3.0V to +5.5V supply and includes undervoltage lockout for controlled startup. Overcurrent protection and thermal shutdown circuitry provides additional protection against excessive power dissipation.

Isolated Power-Supply Application

The MAX13253 allows a versatile range of secondary-side rectification circuits (see [Figure 3](#)). The primary-to-

secondary transformer winding ratio can be chosen to adjust the isolated output voltage. The MAX13253 allows up to 1A of current into the primary transformer winding with a supply voltage up to +5.5V.

Clock Source

Either the internal oscillator or an external clock provides the switching signal for the MAX13253. Connect CLK to ground to select the internal oscillator. Provide an external signal to CLK to automatically select external clocking.

Internal Oscillator Mode

The MAX13253 includes an internal oscillator with a guaranteed 50% duty cycle. Drive the HICLK input high to set the internal oscillator frequency to 600kHz (typ). Drive the HICLK input low to set the internal oscillator frequency to 250kHz (typ).

The MAX13253 features spread-spectrum oscillation for reducing EMI peaks. Drive the SPRD input high to enable spread spectrum on the internal oscillator. Drive the

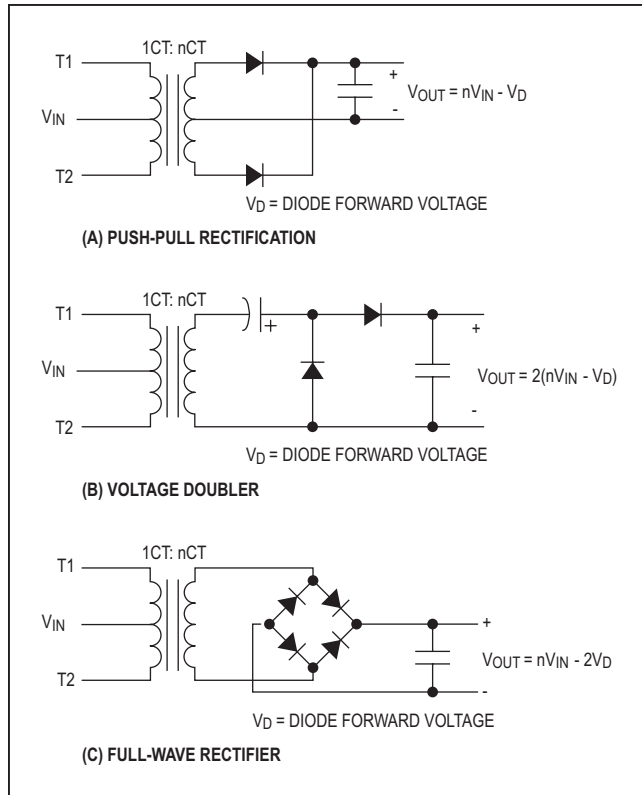

Figure 3. Secondary-Side Rectification Topologies

SPRD input low or leave unconnected to disable spread spectrum on the internal oscillator. SPRD has an internal $10\mu\text{A}$ pull-down to ground.

External Clock Mode

The MAX13253 provides an external clock mode for synchronizing multiple MAX13253 devices. Apply an external clock source to the CLK input to enable external clock mode. An internal flip-flop divides the external clock by two in order to generate a switching signal with a guaranteed 50% duty cycle. As a result, the MAX13253 outputs switch at one-half of the external clock frequency. T1 and T2 switch on the rising edge of the external clock signal.

SPRD has no effect when an external signal is applied to CLK.

Watchdog

When the MAX13253 is operating in external clock mode, a stalled clock can cause excessive DC current to flow through the primary winding of the transformer. The MAX13253 integrates internal watchdog circuitry to prevent damage from this condition. The internal oscillator

provides the switching signal to the driver whenever the period between edges on CLK exceeds the watchdog timeout period of $20\mu\text{s}$ (min).

Slew-Rate Control

The T1 and T2 drivers feature a controlled slew rate to limit EMI.

Disable Mode

The MAX13253 includes a pin-selectable disable mode to reduce current consumption. In disable mode the device consumes less than $5\mu\text{A}$ (max) of supply current. The T1 and T2 outputs are high impedance in disable mode.

Power-Up and Undervoltage Lockout

The MAX13253 provides an undervoltage lockout feature to ensure controlled power-up state and prevent operation before the oscillator has stabilized. On power-up and during normal operation, if the supply voltage drops below the V_{UVLO} , the undervoltage-lockout circuit forces the device into disable mode. The T1 and T2 outputs are high impedance in disable mode.

Overcurrent Limiting

The MAX13253 features overcurrent limiting to protect the IC from excessive currents when charging large capacitive loads or driving into short circuits. Current limiting is achieved in two stages: internal circuitry monitors the output current and detects when the peak current rises above 2A. When the 2A limit is exceeded, internal protection circuitry is immediately enabled, reducing the output current and regulating it to the 1.4A (typ) current-limit threshold. The MAX13253 monitors the driver current on a cycle-by-cycle basis, and the driver output current is regulated to the current-limit threshold until the short is removed.

The MAX13253 can dissipate large amounts of power during overcurrent limiting, causing the IC to enter thermal shutdown.

FAULT Output

The $\overline{\text{FAULT}}$ output is asserted low during an overcurrent or overtemperature fault. $\overline{\text{FAULT}}$ is an open-drain output.

Thermal Shutdown

The MAX13253 is protected from overtemperature damage by integrated thermal-shutdown circuitry. When the junction temperature (T_J) exceeds $+160^\circ\text{C}$ (typ), the device is disabled and $\overline{\text{FAULT}}$ is asserted. $\overline{\text{FAULT}}$ is asserted for the duration of either an overcurrent or overtemperature event. The device resumes normal operation when T_J falls below $+130^\circ\text{C}$ (typ).

Applications Information

Power Dissipation

The power dissipation of the device is approximated by:

$$P_D = (R_O \times I_{PRI}^2) + (I_{DD} \times V_{DD})$$

where R_O is the resistance of the internal FET drivers and I_{PRI} is the load current flowing into T1 and T2. Ensure that the power dissipation of the MAX13253 is kept below the [Absolute Maximum Ratings](#) for proper operation.

High-Temperature Operation

When the MAX13253 is operated under high ambient temperatures, the power dissipated in the package can raise the junction temperature close to the thermal shutdown threshold. Under such temperature conditions, the power dissipation should be held low enough that the junction temperature observes a factor of safety margin. The maximum junction temperature should be held below +140°C. Use the package's thermal resistance to calculate the junction temperature.

Power-Supply Decoupling

Bypass V_{DD} to ground with a 1 μ F ceramic capacitor as close as possible to the device.

Connect at least 10 μ F between V_{DD} and ground as close as possible to the primary-side center tap of the transformer. This capacitor helps to stabilize the voltage on the supply line and protects the IC against large voltage spikes on V_{DD} .

Output Voltage Regulation

For many applications, the unregulated output of the MAX13253 circuit meets output voltage tolerances. This configuration represents the highest efficiency possible. When the load currents on the transformer's secondary side are low, the output voltage of the rectifier can strongly increase. To protect downstream circuitry, limit the output voltage when operating the circuit under low load conditions. If the minimum output load current is less than approximately 5mA, connect a zener diode from the output node of the rectifier to ground to limit the output voltage to a safe value.

For applications requiring a regulated output voltage, Maxim provides several solutions. In the following examples, assume a tolerance of $\pm 10\%$ for the input voltage.

Example 1: 5V to Isolated, Unregulated 6V

In the circuit of [Figure 4](#), the MAX13253 is used to generate an isolated 6V output. For a minimum input voltage of 5V, the output voltage of the rectifier is approximately 6V.

Example 2: 3.3V to Isolated, Regulated 5V

In the circuit of [Figure 5](#), the MAX8881 low-dropout linear regulator regulates the isolated output voltage to 5V. A 1:2 center-tapped transformer is used to step-up the secondary side voltage from a 3.3V input. For a minimum input voltage of 3.3V, the output voltage of the rectifier is approximately 5V.

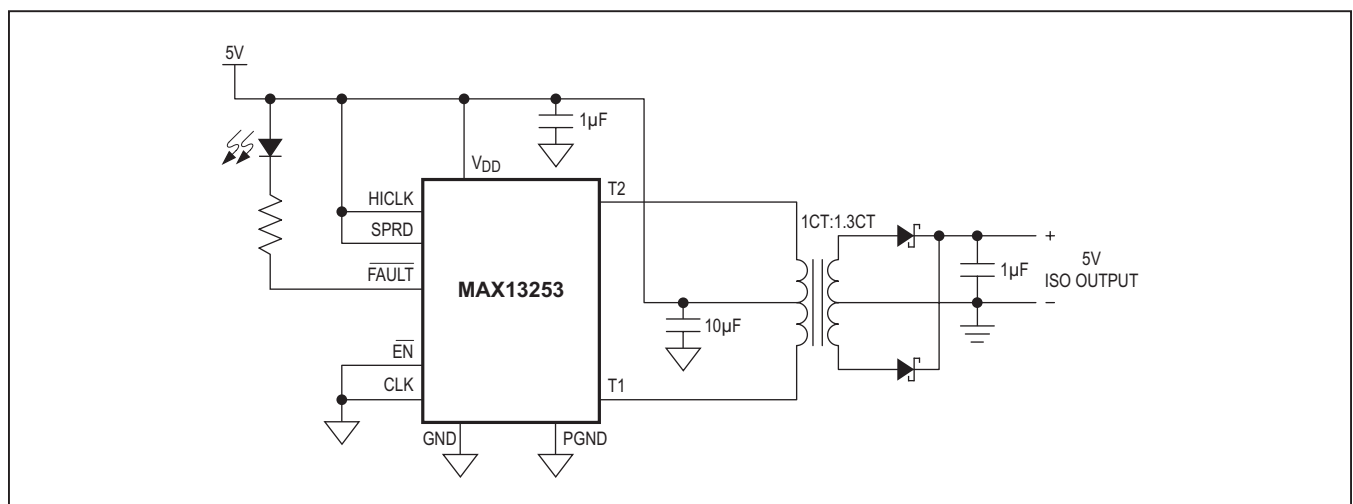

Figure 4. 5V to Isolated, Unregulated 6V Application Circuit

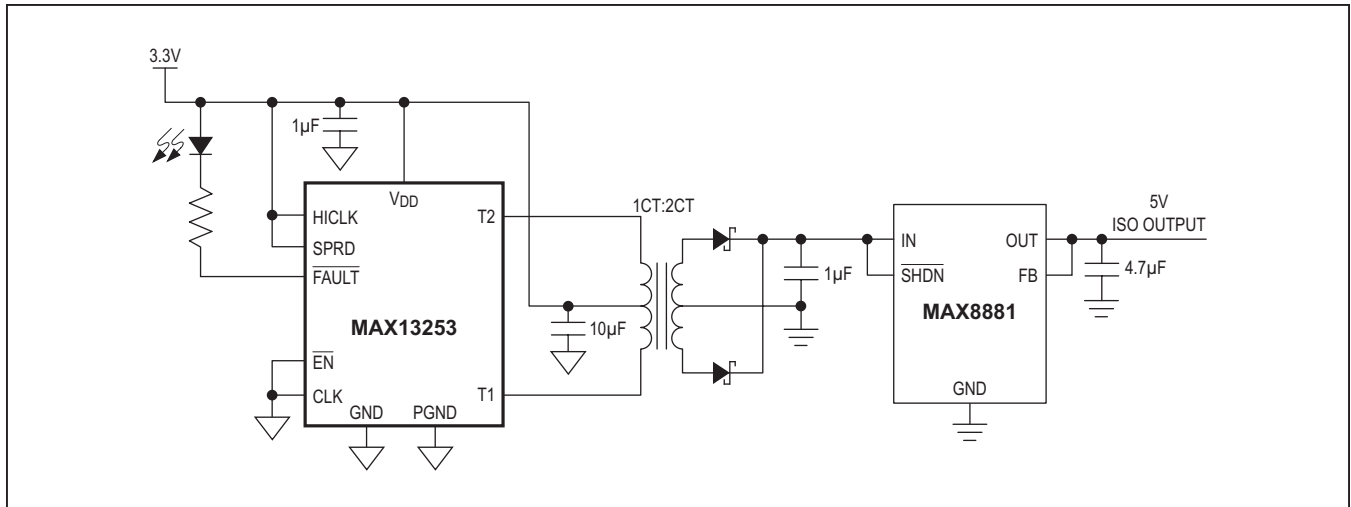

Figure 5. 3.3V to Isolated, Regulated 5V Application Circuit

Isolated USB/RS-485/RS-232 Isolated Applications

The MAX13253 can provide isolated power for USB/RS-485/RS-232 applications. The 1A output current capability of the MAX13253 allows multiple RS-485/RS-232 transceivers to operate simultaneously.

PCB Layout Guidelines

As with all power-supply circuits, careful PCB layout is important to achieve low switching losses and stable operation. Connect the exposed pad to a solid copper ground plane for optimum thermal performance.

The traces from T1 and T2 to the transformer must be low-resistance and low-inductance paths. Locate the transformer as closely as possible to the MAX13253 using short, wide traces.

If possible, use a power plane for all V_{DD} connections to the MAX13253 and the primary-side of the transformer. If a power plane is not available, avoid damage to the IC by ensuring that the current flowing through the primary-side center tap of the transformer does not flow through the same trace that connects the supply pin of the MAX13253 to the V_{DD} source, and connect the primary-side center tap to the V_{DD} supply using a very low-inductance connection.

When the internal oscillator is used, it is possible for high frequency switching on T1 and T2 to couple into the CLK circuitry through PCB parasitic capacitance. This capacitive coupling can induce duty cycle errors in the oscillator, resulting in a DC current through the transformer. For proper operation, ensure that CLK has a solid ground connection.

Exposed Pad

For optimal thermal performance, ensure that the exposed pad has a low thermal resistance connection to the ground plane. Failure to provide a low thermal impedance path to the ground plane results in excessive junction temperatures when dissipating high power.

Component Selection

Transformer Selection

Transformer selection for the MAX13253 can be simplified by the use of the ET product. The ET product relates the maximum allowable magnetic flux density in a transformer core to the voltage across a winding and switching period. Inductor magnetizing current in the primary winding changes linearly with time during the switching period of the MAX13253. Each transformer has a minimum ET product, though not always stated on the transformer data sheet. Ensure that the transformer selected for use with the MAX13253 has an ET product of at least $ET = V_{DD} / (2 \times f_{SW})$ for each half of the primary winding, where f_{SW} is the minimum switching frequency of the T1 and T2 outputs.

Select a transformer with sufficient ET product for each half of the primary winding to ensure that the transformer does not saturate during operation. Saturation of the magnetic core results in significantly reduced inductance of the primary, and therefore in a large increase in current flow. This can cause the current limit to be reached even when the load is not high.

For example, when the internal oscillator is used to drive the outputs and HICLK is low, the required transformer ET product to the center tap for an application with $V_{DD}(\text{max}) = 5.5\text{V}$, is $13.1\text{V}\cdot\mu\text{s}$. An application with $V_{DD}(\text{max}) = 3.3\text{V}$ has a transformer ET product to the center tap requirement of $7.9\text{V}\cdot\mu\text{s}$.

In addition to the constraint on ET product, choose a transformer with low leakage inductance and low DC-winding resistance. Power dissipation of the transformer due to the copper loss is approximated as:

$$P_{D_TX} = I_{LOAD}^2 \times (R_{PRI}/N^2 + R_{SEC})$$

where R_{PRI} is the DC winding resistance of the primary, and R_{SEC} is the DC winding resistance of the secondary. In most cases, an optimum is reached when $R_{SEC} = R_{PRI}/N^2$. For this condition, the power dissipation is equal for the primary and secondary windings.

As with all power-supply designs, it is important to optimize efficiency. In designs incorporating small transformers, the possibility of thermal runaway makes low transformer efficiencies problematic. Transformer losses produce a temperature rise that reduces the efficiency of the transformer. The lower efficiency, in turn, produces an even larger temperature rise.

To ensure that the transformer meets these requirements under all operating conditions, the design should focus on the worst-case conditions. The most stringent demands on ET product arise for maximum input voltage, minimum switching frequency, and maximum temperature and load current. Additionally, the worst-case values for transformer and rectifier losses should be considered.

The primary must be center-tapped; however the secondary winding may or may not be center-tapped, depending on the rectifier topology used. The phasing between primary and secondary windings is not critical.

The transformer turns ratio must be set to provide the minimum required output voltage at the maximum anticipated load with the minimum expected input voltage. In addition, include in the calculations an allowance for the worst-case losses in the rectifiers. Since the turns ratio determined in this manner will ordinarily produce a much higher voltage at the secondary under conditions of high input voltage and/or light loading, be careful to prevent an overvoltage condition from occurring.

Transformers for use with the MAX13253 are typically wound on a high-permeability magnetic core. To minimize radiated electromagnetic emissions, select a toroid, pot core, E/I/U core, or equivalent.

Diode Selection

The high switching speed capability of the MAX13253 necessitates high-speed rectifiers. Ordinary silicon signal diodes such as the 1N914 or 1N4148 can be used for low-output current levels (less than 50mA), but at high output current levels, their reverse recovery times might degrade efficiency. At higher output currents, select low forward-voltage Schottky diodes to improve efficiency. Ensure that the average forward current rating for the rectifier diodes exceeds the maximum load current of the circuit. For surface-mount applications, Schottky diodes such as the B230A, MBRS230, and MBRS320 are recommended.

Suggested External Component Manufacturers

Table 1. Component Manufacturers

MANUFACTURER	COMPONENT	WEBSITE
Halo Electronics	Transformers	www.haloelectronics.com
Würth Electronics	Transformers	www.we-online.com
Diodes Inc.	Diodes	www.diodes.com
Murata Americas	Capacitors	www.murataamericas.com

MAX13253

1A, Spread-Spectrum, Push-Pull, Transformer
Driver for Isolated Power Supplies

Ordering Information

PART	TEMP RANGE	PIN-PACKAGE
MAX13253ATB+	-40°C to +125°C	10 TDFN-EP*

+Denotes lead(Pb)-free/RoHS-compliant package.

*EP = Exposed Pad

Chip Information

PROCESS: BiCMOS

Revision History

REVISION NUMBER	REVISION DATE	DESCRIPTION	PAGES CHANGED
0	3/13	Initial release	—
1	4/13	Updated TOC parameters, updated Figure 4, replaced Figure 5, updated the <i>Output Voltage Regulation</i> section	5, 6, 10, 11
2	9/18	Updated TOC06–TOC13, and updated Table 1	5, 6, 12

For pricing, delivery, and ordering information, please visit Maxim Integrated's online storefront at <https://www.maximintegrated.com/en/storefront/storefront.html>.

Maxim Integrated cannot assume responsibility for use of any circuitry other than circuitry entirely embodied in a Maxim Integrated product. No circuit patent licenses are implied. Maxim Integrated reserves the right to change the circuitry and specifications without notice at any time. The parametric values (min and max limits) shown in the Electrical Characteristics table are guaranteed. Other parametric values quoted in this data sheet are provided for guidance.

Looking for pricing, stock, or lifecycle information?

Click below to explore more details on WIN SOURCE:

- ⊖ [View MAX13253ATB+T on WIN SOURCE](#)
- ⊖ [Maxim Integrated Information](#)

Optimize Your Supply Chain with WIN SOURCE Solutions

- ✓ Global Sourcing Solution
- ✓ Obsolete Management
- ✓ Cost Control Management
- ✓ Shortage Management
- ✓ Alternative Solution
- ✓ Excess Inventory Management