



**THE DATASHEET OF  
MC34933EP**



# 1.4 A Dual H-Bridge Driver Compatible with 3.0 V Logic

The 34933 is a two channel H-Bridge driver aimed at the digital camera market. There are a variety of applications containing bipolar step motors and/or brush DC motors, such as Auto Focus control for the digital camera lens. The 34933 uses Freescale's proprietary SMARTMOS process to deliver a low-power device, with a maximum quiescent current of 100  $\mu$ A for the motor drive supply and 400 $\mu$ A for the control logic supply.

The 34933  $V_M$  supply operates from 2.0 V to 7.0 V using an internal charge pump, with independent control of each H-Bridge driver via the MCU (IN1A, IN1B, IN2A, IN2B). The 34933 has a low total  $R_{DS(on)}$  of 1.0  $\Omega$  (max. at 25  $^{\circ}$ C). Shoot-through current protection is a built-in feature for the 34933 device.

The 34933 has four operation modes: forward, reverse, brake, and tri-state (high-impedance). The 34933 employs a  $V_{CC}$  detection circuit to sense when the logic supply switches to an off-state with a maximum current of 1.0  $\mu$ A to extend battery life. The H-Bridge drivers can be independently pulse width modulated up to 200 kHz for speed/ torque and/or current control. Note that tri-state mode of H-Bridge drivers can occur when either  $V_{CC}$  detect is low or the thermal detect is active.

### Features

- Built-in 2-channel H-Bridge driver
- H-Bridge operation voltage 2.0 V to 7.0 V
- Max. load output current 1.0 A at  $T_A = 25^{\circ}$ C
- Low total  $R_{DS(ON)}$  0.8  $\Omega$  (typ), 1.0  $\Omega$  (max.) @  $T_A = 25^{\circ}$ C peak
- Dual channel parallel driver,  $R_{DS(ON)}$  0.4  $\Omega$  (typ.). max. DC current 1.4 A
- PWM control input frequency up to 200 kHz
- Built-in shoot-through current prevention circuit
- Built-in charge pump circuit (external cap type)
- $V_{CC}$  low voltage detection for logic power supply voltage
- Thermal detection for H-Bridge driver

**34933**

**H-BRIDGE DRIVER**



ORDERING INFORMATION		
Device (For Tape and Reel, add an R2 Suffix)	Temperature Range ( $T_A$ )	Package
MC34933EP	-20 $^{\circ}$ C to 85 $^{\circ}$ C	16-UQFN

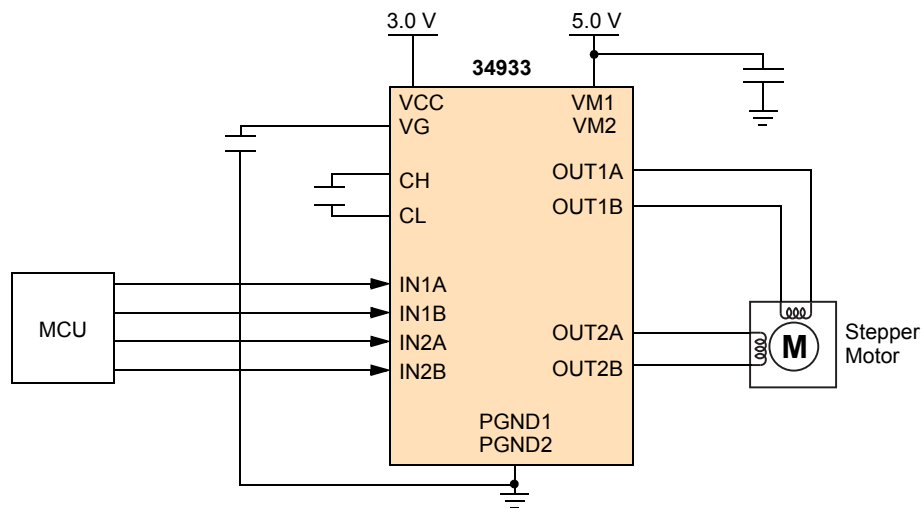

**Figure 1. 34933 Simplified Application Diagram**

### INTERNAL BLOCK DIAGRAM

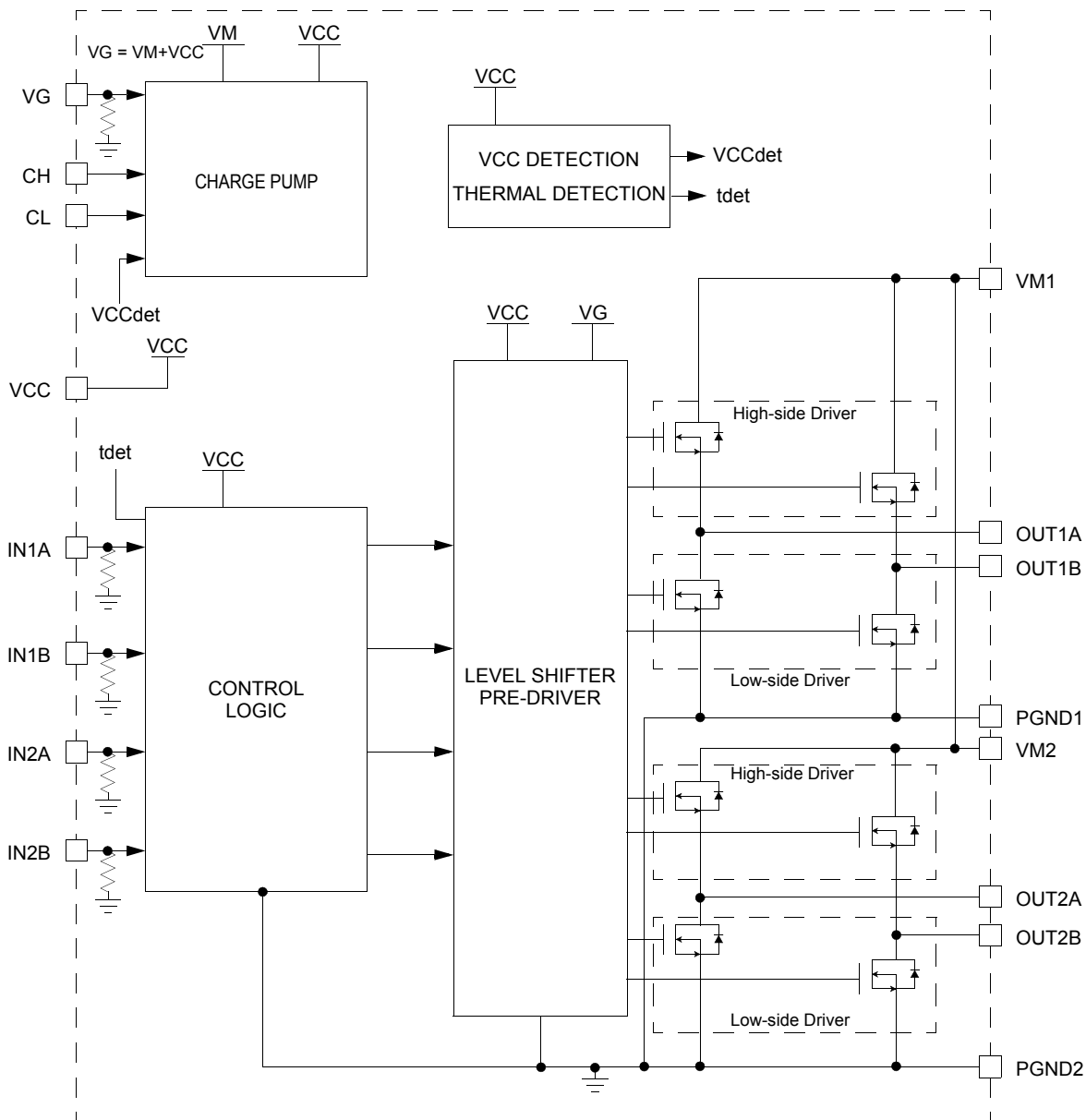

\* VM1 and VM2 are connected internally. Both VM1 and VM2 must be tied together on the PCB.  
 PGND1 and PGND2 are connected internally. Both PGND1 and PGND2 must be tied together on the PCB.

**Figure 2. 34933 Simplified Internal Block Diagram**

## PIN CONNECTIONS

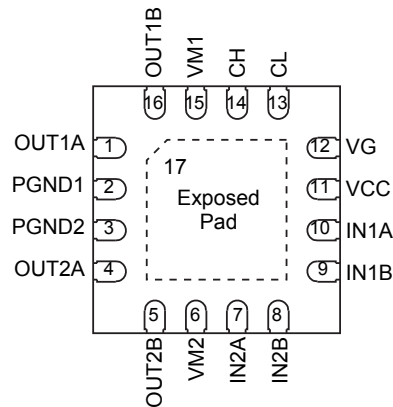

Figure 3. 34933 Pin Connections

Table 1. 34933 Pin Definitions

Pin Number	Pin Name	Pin Function	Formal Name	Definition
1	OUT1A	Output	H-Bridge Output 1A	Output A of H-Bridge channel 1.
2	PGND1	Power supply	Power Ground 1	Power supply grounds for the 34933 device. Refer to the application diagram for recommended layout.
3	PGND2	Power supply	Power Ground 2	Power supply grounds for the 34933 device. Refer to the application diagram for recommended layout.
4	OUT2A	Output	H-Bridge Output 2A	Output A of H-Bridge channel 2
5	OUT2B	Output	H-Bridge Output 2B	Output B of H-Bridge channel 2
6	VM2	Power supply	Motor Drive Power Supply 2	Power supply pins for the 34933 motor drive circuitry. Refer to the application diagram for recommended layout.
7	IN2A	Input	Logic Input Control 2A	Logic input control of OUT2A
8	IN2B	Input	Logic Input Control 2B	Logic input control of OUT2B
9	IN1B	Input	Logic Input Control 1B	Logic input control of OUT1B
10	IN1A	Input	Logic Input Control 1A	Logic input control of OUT1A
11	VCC	Power supply	Control Logic Power Supply	Power supply for the control logic circuitry.
12	VG	Output	Charge Pump Output Capacitor	Charge pump output pin connected to an external capacitor. The $V_G$ voltage is the sum of the $V_{CC}$ and $V_M$ power supplies.
13	CL	Input/Output	Charge Pump Capacitor 1	Low-side charge pump capacitor connection
14	CH	Input/Output	Charge Pump Capacitor 2	High-side charge pump capacitor connection
15	VM1	Power supply	Motor Drive Power Supply 1	Power Supply pins for the 34933 motor drive circuitry. Refer to the application diagram for recommended layout.
16	OUT1B	Output	H-Bridge Output 1B	Output B of H-Bridge channel 1
17 <sup>(1)</sup>	Exposed Pad	Power supply	EP	The exposed pad is connected to ground plane via the exposed pad solder pad. Note the primary purpose of the exposed pad for 34933 is thermal heat dissipation. Therefore, adequate thermal vias should be included in the PCB design.

Notes

- Exposed pad is used as a heat sink. Connect it to the power ground through four thermal vias where the area is wide.

## ELECTRICAL CHARACTERISTICS

### MAXIMUM RATINGS

**Table 2. Maximum Ratings**

All voltages are with respect to ground unless otherwise noted. Exceeding these ratings may cause a malfunction or permanent damage to the device.

Ratings	Symbol	Value	Unit
<b>ELECTRICAL RATINGS</b>			
Control Logic Power Supply Voltage	VCC	-0.5 to +6.0	V
Motor Drive Power Supply	VM	-0.5 to +7.5	V
VCC Level Pin Voltage - IN1A, IN1B, IN2A, IN2B	Vpin1	-0.5 to +5.5	V
VM Level Pin Voltage - OUT1A, OUT1B, OUT2A, OUT2B, CL	Vpin2	-0.5 to +7.5	V
VM+VCC Level Pin Voltage - CH, VG	Vpin3	-0.5 to +13.5	V
Motor Drive Maximum Load Current, $T_A = 85\text{ }^\circ\text{C}$	$I_{LOAD\_DC\_MD}$	0.7	A
Motor Drive Maximum Load Current, $T_A = 25\text{ }^\circ\text{C}$	$I_{LOAD\_DC\_MD}$	1.0	A
Motor Drive Maximum Peak Load Current <sup>(3)</sup>	$I_{LOAD\_PEAK\_MD}$	1.4	A
Power Dissipation <sup>(4)</sup>	$P_D$	1.0	W
ESD Voltage <sup>(2)</sup>	$V_{ESD}$		V
Human Body Model (HBM)		±4000	
Machine Model (MM)		±350	
Charge Device Model (CDM)		±1000	
<b>THERMAL RATINGS</b>			
Operating Temperature Range	$T_A$	-20 to +85	$^\circ\text{C}$
Operating Junction Temperature	$T_J$	150	$^\circ\text{C}$
Storage Temperature Range	$T_{STG}$	-65 to +150	$^\circ\text{C}$
<b>THERMAL RESISTANCE</b>			
Thermal Resistance, Junction to Case <sup>(5)</sup>	$R_{\theta JC}$	23	$^\circ\text{C/W}$
Peak Package Reflow Temperature During Reflow <sup>(6), (7)</sup>	$T_{PPRT}$	Note 7	$^\circ\text{C}$

Notes

- ESD testing is performed in accordance with the Human Body Model (HBM) ( $C_{ZAP} = 100\text{ pF}$ ,  $R_{ZAP} = 1500\text{ }\Omega$ ), the Machine Model (MM) ( $C_{ZAP} = 200\text{ pF}$ ,  $R_{ZAP} = 0\text{ }\Omega$ ), and the Charge Device Model (CDM), Robotic ( $C_{ZAP} = 4.0\text{ pF}$ ).
- Peak time is for 10 ms pulse width at 200 ms intervals.  $T_A = 25\text{ }^\circ\text{C}$ .
- $R_{\theta JA} = 50\text{ }^\circ\text{C/W}$ , in case of 2s2p printed circuit board that defined on SEMI JEDEC JESD51- 3 and JESD51-6.
- Thermal resistance between the die and the case top surface as measured by the cold plate method (MIL SPEC-883 Method 1012.1).
- Pin soldering temperature limit is for 10 seconds maximum duration. Not designed for immersion soldering. Exceeding these limits may cause malfunction or permanent damage to the device.
- Freescale's Package Reflow capability meets Pb-free requirements for JEDEC standard J-STD-020C. For Peak Package Reflow Temperature and Moisture Sensitivity Levels (MSL), go to [www.freescale.com](http://www.freescale.com), search by part number [e.g. remove prefixes/suffixes and enter the core ID to view all orderable parts. (i.e. MC33xxx enter 33xxx), and review parametrics.

### STATIC AND DYNAMIC ELECTRICAL CHARACTERISTICS

**Table 3. Static and Dynamic Electrical Characteristics**

Characteristics noted under conditions,  $V_M = 5.0\text{ V}$ ,  $V_{CC} = 3.0\text{ V}$ , unless otherwise noted. Typical values noted reflect the approximate parameter means at  $T_A = 25\text{ °C}$  under nominal conditions, unless otherwise noted.

Characteristic	Symbol	Min	Typ	Max	Unit
<b>POWER SUPPLY</b>					
Motor Drive Power Supply Voltage	$V_M$	2.0	5.0	7.0	V
Control Logic Power Supply Voltage	$V_{CC}$	2.7	3.0	5.5	V
Driver Quiescent Supply Current (IN1A, IN1B, IN2A, IN2B = L) No Signal Input	$I_{QM}$	-	72	100	$\mu\text{A}$
Logic Quiescent Supply Current (IN1A, IN1B, IN2A, IN2B = L) No Signal Input	$I_{QVCC}$	-	114	400	$\mu\text{A}$
Control Logic Power Supply Operating Current (IN1A, IN2A = L, IN1B, IN2B = 200kHz)	$I_{VCC}$	-	350	800	$\mu\text{A}$
Charge Pump Target Voltage $V_M = 2.0\text{ V}$ , $V_{CC} = 2.7\text{ V}$ , $I_{LOAD} = 0\text{ A}$ $V_M = 5.0\text{ V}$ , $V_{CC} = 3.0\text{ V}$ , $I_{LOAD} = 0\text{ A}$ $V_M = 7.0\text{ V}$ , $V_{CC} = 5.5\text{ V}$ , $I_{LOAD} = 0\text{ A}$	$V_G$	4.2 7.6 12.0	4.45 7.8 12.3	4.7 8.0 12.5	V
Charge Pump Wake-up Time Charge pump is enabled in $V_{CC} > V_{CCDET}$	$T_{VGON}$	-	130	400	$\mu\text{s}$
Driver Quiescent Supply Current at $V_{CCDET} = L$ $V_M = 5.0\text{ V}$ , $V_{CC} = 0\text{ V}$	$I_{QM\_VCD = L}$	-	-	1.0	$\mu\text{A}$
Charge Pump Switching Frequency	$F_{QP}$	-	150	-	kHz
<b>H-BRIDGE DRIVER</b>					
H-Bridge Driver High/Low-side Driver On-Resistance 1 $V_{CC} = 2.7\text{ V}$ , $I_{SINK} = 100\text{ mA}$ , $T_A = 25\text{ °C}$	$R_{ON1}$	-	0.4	0.45	$\Omega$
H-Bridge Driver High/Low-side Driver On-Resistance 2 <sup>(8)</sup> $V_{CC} = 2.7\text{ V}$ , $I_{SINK} = 700\text{ mA}$ , $T_A = 25\text{ °C}$	$R_{ON2}$	-	0.43	0.51	$\Omega$
H-Bridge Driver High/Low-side Driver On-Resistance 3 <sup>(8)</sup> $V_{CC} = 2.7\text{ V}$ , $I_{SINK} = 700\text{ mA}$ , $T_A = 85\text{ °C}$	$R_{ON3}$	-	0.51	0.62	$\Omega$
H-Bridge Driver High/Low-side Driver On-Resistance 4 $V_{CC} = 3.0\text{ V}$ , $I_{SINK} = 100\text{ mA}$ , $T_A = 25\text{ °C}$	$R_{ON4}$	-	0.39	0.43	$\Omega$
H-Bridge Driver High/Low-side Driver On-Resistance 5 <sup>(8)</sup> $V_{CC} = 3.0\text{ V}$ , $I_{SINK} = 700\text{ mA}$ , $T_A = 25\text{ °C}$	$R_{ON5}$	-	0.41	0.48	$\Omega$
H-Bridge Driver High/Low-side Driver On-Resistance 6 <sup>(8)</sup> $V_{CC} = 3.0\text{ V}$ , $I_{SINK} = 700\text{ mA}$ , $T_A = 85\text{ °C}$	$R_{ON6}$	-	0.49	0.58	$\Omega$
H-Bridge Driver Output Body Diode Forward Voltage $I_f = 100\text{ mA}$	$V_F$	-	0.8	1.2	V
Input Pulse Frequency (INA/B) Duty of input signal = 50 %	$F_{IN}$	-	-	200	kHz

**Notes**

8. Guaranteed by design

**Table 3. Static and Dynamic Electrical Characteristics**

Characteristics noted under conditions,  $V_M = 5.0\text{ V}$ ,  $V_{CC} = 3.0\text{ V}$ , unless otherwise noted. Typical values noted reflect the approximate parameter means at  $T_A = 25\text{ }^\circ\text{C}$  under nominal conditions, unless otherwise noted.

Characteristic	Symbol	Min	Typ	Max	Unit
<b>H-BRIDGE DRIVER (CONTINUED)</b>					
H-Bridge Output Propagation Delay Time for OUTA/B (H to L) $R_{LOAD} = (1.0\text{ k}\Omega)$ between OUTA and OUTB (refer to <a href="#">Figure 4</a> ) (IN1A, IN2A = L, IN1B, IN2B = 200 kHz)	$t_{PDHL}$	-	0.1	0.5	$\mu\text{s}$
H-Bridge Output Propagation Delay Time for OUTA/B (L to H) $R_{LOAD} = (1.0\text{ k}\Omega)$ between OUTA and OUTB (refer to <a href="#">Figure 4</a> ) (IN1A, IN2A = L, IN1B, IN2B = 200 kHz)	$t_{PDLH}$	-	0.1	0.5	$\mu\text{s}$
H-Bridge Output Pulse Width $R_{LOAD} = 20\text{ }\Omega$ between OUTA and OUTB, Input Pulse Width = $1.0\text{ }\mu\text{s}$ , 50% to 50%, $t_{PW}$ : 50% to 50% (refer to <a href="#">Figure 5</a> )	$t_{PW}$	0.7	-	-	$\mu\text{s}$
H-Bridge Output Propagation Delay Time (Hi-Z to H) <sup>(8)</sup> $R_{LOAD} = 100\text{ k}\Omega$ to $1/2 \cdot V_M$ , $C_{LOAD} = 0\text{ pF}$ , $t_{PDZH}$ 50% to 75%	$t_{PDZH}$	-	-	0.5	$\mu\text{s}$
H-Bridge Output Propagation Delay- Time (H to Hi-Z) <sup>(8)</sup> $R_{LOAD} = 100\text{ k}\Omega$ to $1/2 \cdot V_M$ , $C_{LOAD} = 0\text{ pF}$ , $t_{PDHZ}$ 75% to 50%	$t_{PDHZ}$	-	-	2.0	$\mu\text{s}$

**CONTROL LOGIC**

High Level Input Voltage (IN1A, IN1B, IN2A, IN2B) $V_{CC} = 2.7\text{ V} \sim 5.5\text{ V}$	$V_{IH}$	$V_{CC} \times 0.7$	-	-	V
Low Level Input Voltage (IN1A, IN1B, IN2A, IN2B) $V_{CC} = 2.7\text{ V} \sim 5.5\text{ V}$	$V_{IL}$	-	-	$V_{CC} \times 0.3$	V
High Level Input Current (IN1A, IN1B, IN2A, IN2B) $V_{TERMAINAL1} = 3.0\text{ V}$	$I_{IH}$	9	-	20	$\mu\text{A}$
Low Level Input Current (IN1A, IN1B, IN2A, IN2B) $V_{CC} = 2.7\text{ V to } 5.5\text{ V}$	$I_{IL}$	-1.0	-	-	$\mu\text{A}$
Input Pulse Rise Time (IN1A, IN1B, IN2A, IN2B) $V_{CC} = 2.7\text{ V to } 5.5\text{ V}$	$t_R$	-	-	1.0	$\mu\text{s}$
Input Pulse Fall Time (IN1A, IN1B, IN2A, IN2B) $V_{CC} = 2.7\text{ V to } 5.5\text{ V}$	$t_F$	-	-	1.0	$\mu\text{s}$

**DETECTOR**

VCC Detection Voltage (refer to <a href="#">Figure 6</a> )	$V_{CCDET}$	2.0	2.2	2.4	V
VCC Detection hysteresis Voltage (refer to <a href="#">Figure 6</a> )	$V_{CCDETHYS}$	0.05	0.1	0.3	V
Thermal Detection Temperature <sup>(9)</sup>	$T_{DET}$	150	170	190	$^\circ\text{C}$
Thermal Detection Hysteresis Temperature <sup>(9)</sup>	$T_{DETHYS}$	10	20	30	$^\circ\text{C}$

Notes

9. Guaranteed by design

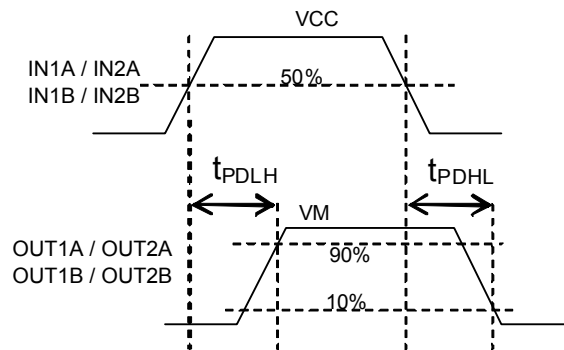
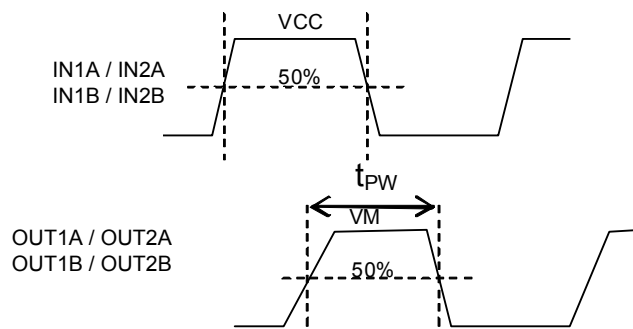
**TIMING DIAGRAMS**

**Figure 4.  $t_{PDLH}$  and  $t_{PDHL}$  Timing**

**Figure 5.  $t_{PW}$  Timing**
**Table 4. Truth Table**

Vccdet	Tdet	INPUT		OUTPUT	
		IN1A IN2A	IN1B IN2B	OUT1A OUT2A	OUT1B OUT2B
L	X	X	X	Z	Z
H	L	L	L	L	L
H	L	H	L	H	L
H	L	L	H	L	H
H	L	H	H	Z	Z
H	H	X	X	Z	Z

H - High  
 L - Low  
 Z - High-impedance  
 X - Don't Care

Figure 6 and Figure 7 show the timing charts of input and output signals

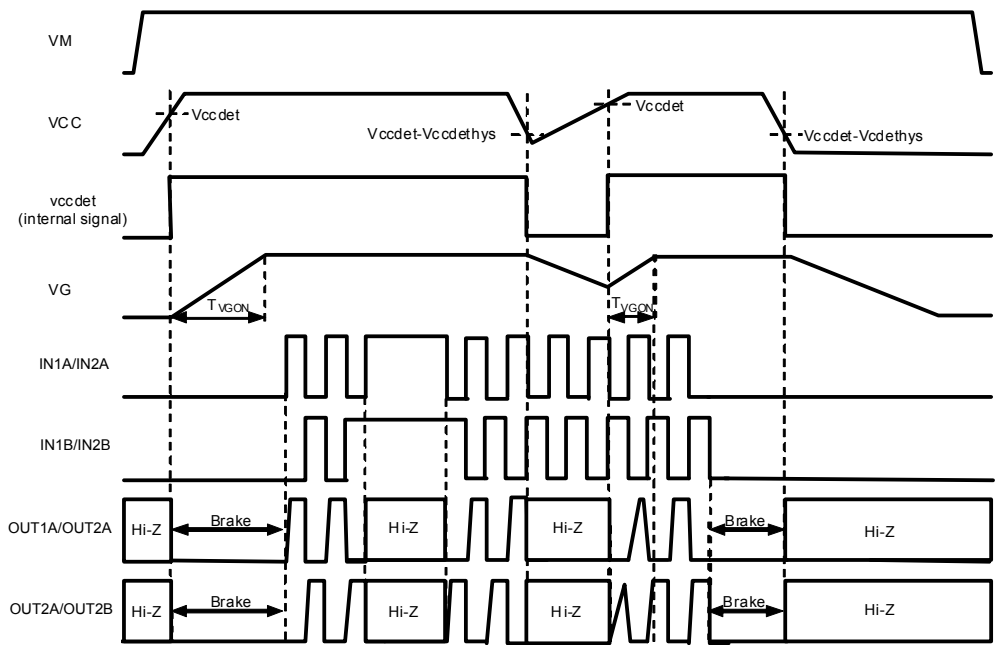

Figure 6. Timing Chart of Input and Output Signal (V<sub>CCDET</sub> case)

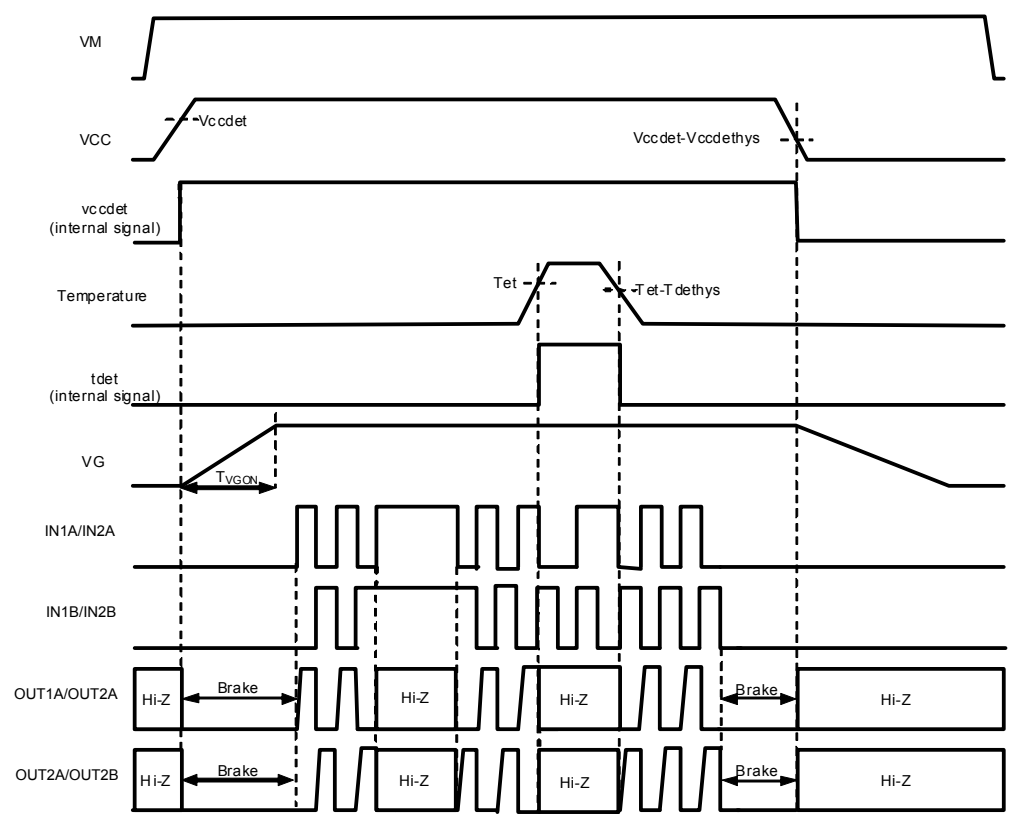

Figure 7. Timing Chart of Input and Output Signal (t<sub>DET</sub> case)

## FUNCTIONAL DESCRIPTION

### FUNCTIONAL PIN DESCRIPTION

#### LOGIC SUPPLY (VCC)

The VCC pin carries the logic supply voltage and current into the logic sections of the IC. VCC has an under-voltage threshold. If the supply voltage drops below the under-voltage threshold, the output power stage switches to a tri-state condition. When the supply voltage returns to a level that is above the threshold, the power stage automatically resumes normal operation according to the established condition of the input pins.

#### LOGIC INPUT CONTROL (IN1A, IN1B, IN2A, AND IN2B)

These logic input pins control each H-Bridge output. IN1A logic HIGH = OUT1A HIGH. However, if all inputs are HIGH, the output bridges are both tri-stated (refer to [Table 4](#), Truth Table).

#### H-BRIDGE OUTPUT (OUT1A, OUT1B, OUT2A, AND OUT2B)

These pins provide connection to the outputs of each of the internal H-Bridges (See [Figure 2](#), 34933 Simplified Internal Block Diagram).

#### MOTOR DRIVE POWER SUPPLY (VM1 AND VM2)

The VM pins carry the main supply voltage and current into the power sections of the IC. This supply then becomes controlled and/or modulated by the IC as it delivers the power to the loads attached between the output pins. All VM pins must be connected together on the Printed Circuit Board (PCB).

#### CHARGE PUMP (CL AND CH)

These two pins, the CL and CH, connect to the external bucket capacitors required by the internal charge pump. The typical value for the bucket capacitors is 0.1  $\mu$ F.

#### POWER GROUND (PGND)

Power ground pins must be tied together on the PCB and connected to the common ground plane.

#### LOGIC GROUND (EXPOSED PAD)

The Exposed Pad is connected to the PCB Ground plane through vias by soldering. Note the primary purpose of the Exposed pad for 34933 is thermal heat dissipation. Therefore, adequate thermal vias should be included in the PCB design. The exposed pad should be connected to the common ground plane.

### VOLTAGE DETECTION AND THERMAL LIMIT DETECTION

The 34933 has the VCC Low Voltage Detection (Vccdet) and the Thermal Detection ( $T_{DET}$ ). VCC Low Voltage Detection is designed to shutdown of IC functions when VCC becomes lower than specified voltage. Thermal Detection operates when the IC temperature exceeds specified value

and stop H-Bridge operation. [Table 5](#) shows block status of 34933 by each condition. VCC is the control logic power supply for 34933. The system begins to operate when  $V_{CC} > V_{CCDET}$  (Typ. 2.2 V).

**Table 5. Block Status**

Operation mode	Vccdet	Tdet	Charge Pump	H-Bridge Driver
1	L	X	Disable	Disable
2	H	L	Enable	Enable
3	H	H	Enable	Disable

H - High  
 L - Low  
 X - Don't Care

## TYPICAL APPLICATION

Figure 8 shows a typical application using the 34933. The internal charge pump of this device is powered from the  $V_{CC}$  supply. Therefore, care must be taken to ensure  $V_{CC}$  is a high enough value to provide sufficient gate-source voltage for the high-side MOSFETs when  $V_M > V_{CC}$  (e.g.,  $V_M = 5.0\text{ V}$ ,  $V_{CC} = 3.0\text{ V}$ ), in order to ensure full enhancement of the high-side MOSFET channels.

The 34933 can be configured in several applications. The figure below shows the 34933 in a typical Slave Node Application.

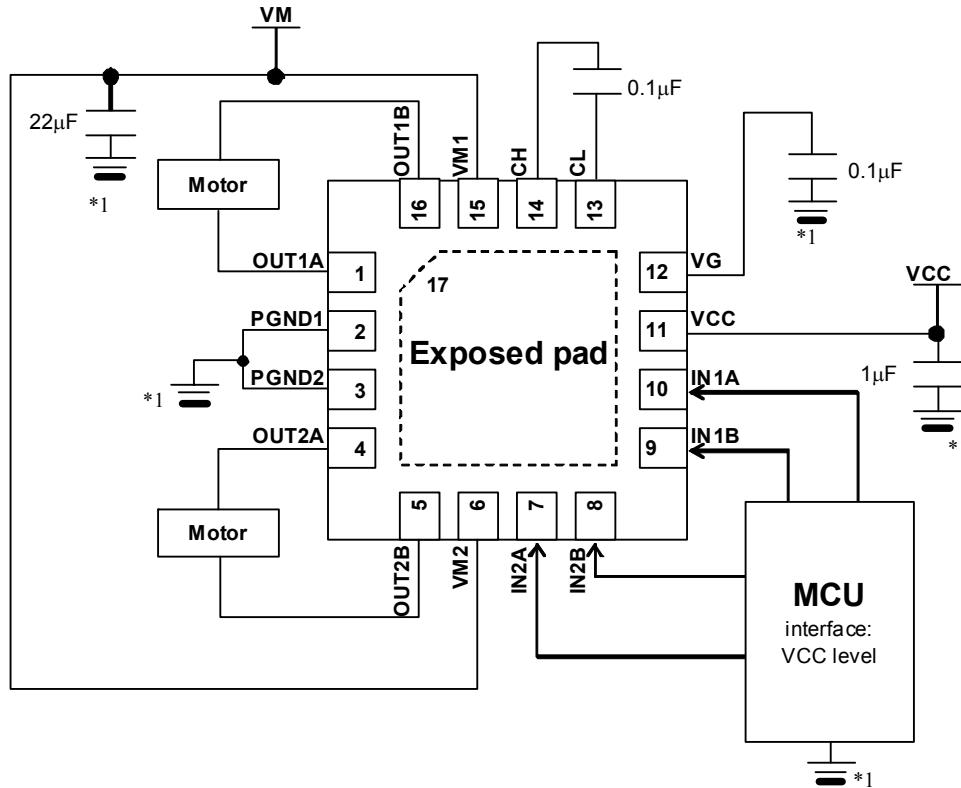

\*1 - It is recommended to use low resistance copper PCB traces between VM & VCC ground and the PGND1/PGND2 pins.

Figure 8. Typical Application

## PCB LAYOUT

When designing a printed circuit board (PCB), connect sufficient capacitance between power supplies (VM & VCC) and ground pins to ensure proper filtering from transients. For all high-current paths, use wide copper traces and the shortest possible distances. Note that capacitors should be placed as close to the 34933 as possible to maximize the filtering capability of each capacitor.

Additionally, care must be taken to avoid CEMF spikes induced when inductive currents accumulate at the VM supply. The typical method of snubbing inductive spikes includes connecting a Zener diode or capacitor at the supply pin (VM).

## PACKAGING

### PACKAGE DIMENSIONS

Package dimensions are provided in package drawings. To find the most current package outline drawing, go to [www.freescale.com](http://www.freescale.com) and perform a keyword search for the drawing's document number.

**Table 6.**

Package	Suffix	Package Outline Drawing Number
16-PIN UQFN	EP	98ASA00717D

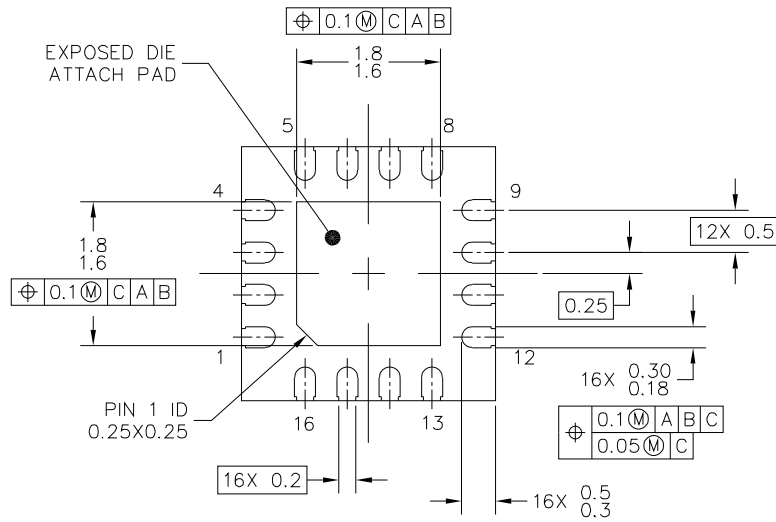
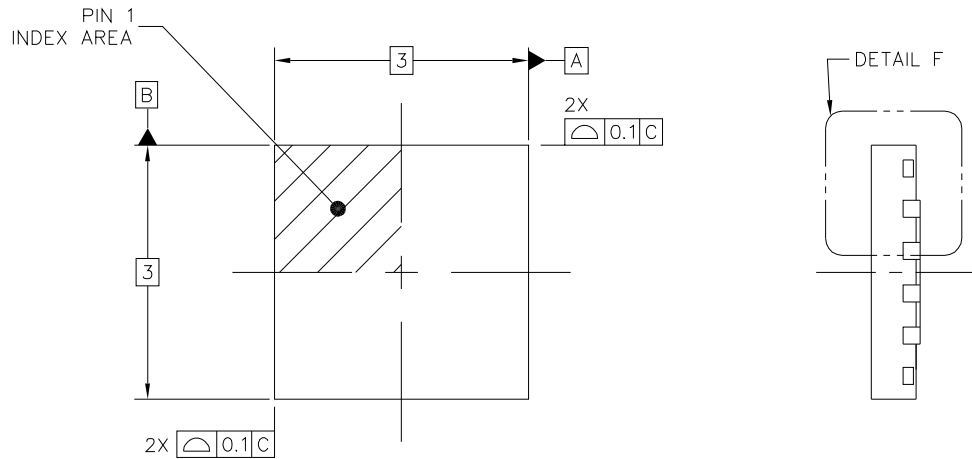

© FREESCALE SEMICONDUCTOR, INC. ALL RIGHTS RESERVED.	MECHANICAL OUTLINE	PRINT VERSION NOT TO SCALE
TITLE: QFN, THERMALLY ENHANCED, 3 X 3 X 0.58, 0.5 PITCH, 16 TERMINAL	DOCUMENT NO: 98ASA00717D	REV: 0
	STANDARD: NON-JEDEC	
	21 APR 2014	

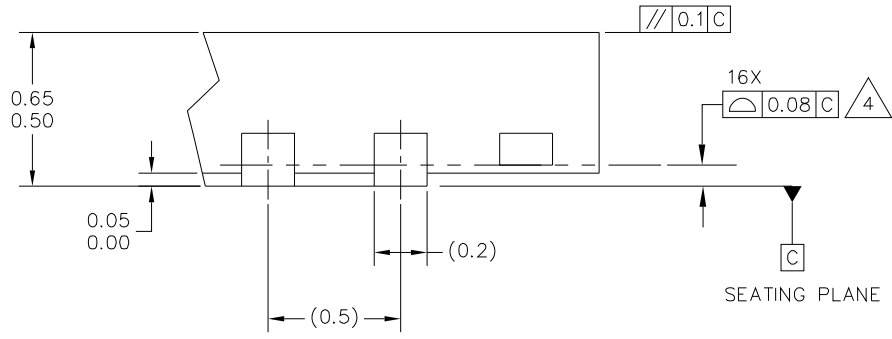

DETAIL F  
VIEW ROTATED 90°CW

© FREESCALE SEMICONDUCTOR, INC. ALL RIGHTS RESERVED.	MECHANICAL OUTLINE	PRINT VERSION NOT TO SCALE
TITLE: QFN, THERMALLY ENHANCED, 3 X 3 X 0.58, 0.5 PITCH, 16 TERMINAL	DOCUMENT NO: 98ASA00717D	REV: 0
	STANDARD: NON-JEDEC	
	21 APR 2014	

NOTES:

1. ALL DIMENSIONS ARE IN MILLIMETERS.
2. DIMENSIONING AND TOLERANCING PER ASME Y14.5M-1994.
3. THIS IS A NON-JEDEC REGISTERED PACKAGE.
4.  COPLANARITY APPLIES TO LEADS AND DIE ATTACH FLAG.
5. MIN. METAL GAP SHOULD BE 0.2 MM.

© FREESCALE SEMICONDUCTOR, INC. ALL RIGHTS RESERVED.	MECHANICAL OUTLINE	PRINT VERSION NOT TO SCALE	
TITLE: QFN, THERMALLY ENHANCED, 3 X 3 X 0.58, 0.5 PITCH, 16 TERMINAL		DOCUMENT NO: 98ASA00717D	REV: 0
		STANDARD: NON-JEDEC	
		21 APR 2014	

## REVISION HISTORY

REVISION	DATE	DESCRIPTION OF CHANGES
2.0	7/2010	<ul style="list-style-type: none"> <li>• Initial Release.</li> </ul>
	12/2013	<ul style="list-style-type: none"> <li>• No technical changes</li> <li>• Revised back page</li> <li>• Updated document properties</li> </ul>
3.0	9/2014	<ul style="list-style-type: none"> <li>• Changed 98A to 98ASA00717D</li> <li>• Update format</li> </ul>

**How to Reach Us:**

**Home Page:**  
[freescale.com](http://freescale.com)

**Web Support:**  
[freescale.com/support](http://freescale.com/support)

Information in this document is provided solely to enable system and software implementers to use Freescale products. There are no express or implied copyright licenses granted hereunder to design or fabricate any integrated circuits based on the information in this document.

Freescale reserves the right to make changes without further notice to any products herein. Freescale makes no warranty, representation, or guarantee regarding the suitability of its products for any particular purpose, nor does Freescale assume any liability arising out of the application or use of any product or circuit, and specifically disclaims any and all liability, including without limitation consequential or incidental damages. "Typical" parameters that may be provided in Freescale data sheets and/or specifications can and do vary in different applications, and actual performance may vary over time. All operating parameters, including "typicals," must be validated for each customer application by customer's technical experts. Freescale does not convey any license under its patent rights nor the rights of others. Freescale sells products pursuant to standard terms and conditions of sale, which can be found at the following address: [freescale.com/SalesTermsandConditions](http://freescale.com/SalesTermsandConditions).

Freescale and the Freescale logo are trademarks of Freescale Semiconductor, Inc., Reg. U.S. Pat. & Tm. Off. SMARTMOS is a trademark of Freescale Semiconductor, Inc. All other product or service names are the property of their respective owners.

© 2014 Freescale Semiconductor, Inc.

Document Number: MC34933  
Rev. 3.0  
9/2014

## Looking for pricing, stock, or lifecycle information?

Click below to explore more details on WIN SOURCE:

 [View MC34933EP](#) on WIN SOURCE

 [NXP / Nexperia](#) Information

## Optimize Your Supply Chain with WIN SOURCE Solutions

-  Global Sourcing Solution
-  Obsolete Management
-  Cost Control Management
-  Shortage Management
-  Alternative Solution
-  Excess Inventory Management