



**THE DATASHEET OF
NCP5359MNR2G**



NCP5359

Gate Driver for Notebook Power Systems

The NCP5359 is a high performance dual MOSFET gate driver optimized to drive the gates of both high-side and low-side power MOSFETs in a synchronous buck converter. Each of the drivers can drive up to 3 nF load with a 25 ns propagation delay and 20 ns transition time.

Adaptive nonoverlap and power saving operation circuit can provide a low switching loss and high efficiency solution for notebook and desktop systems.

A high floating top driver design can accommodate VBST voltage as high as 35 V, with transient voltages as high as 35 V. Bidirectional EN pin can provide a fault signal to controller when the gate driver fault detect under OVP, UVLO occur. Also, an undervoltage lockout function guarantees the outputs are low when supply voltage is low, and a thermal shutdown function provides the IC with overtemperature protection.

Features

- Faster Rise and Fall Times
- Thermal Shutdown Protection
- Adaptive Nonoverlap Circuit
- Floating Top Driver Accommodates Boost Voltages of up to 35 V
- Output Disable Control Turns Off Both MOSFETs
- Complies with VRM 11.1 Specifications
- Undervoltage Lockout
- Power Saving Operation Under Light Load Conditions
- Thermally Enhanced Package
- These are Pb-Free Devices

Typical Applications

- Power Solutions for Desktop and Notebook Systems



ON Semiconductor®

<http://onsemi.com>

MARKING DIAGRAMS

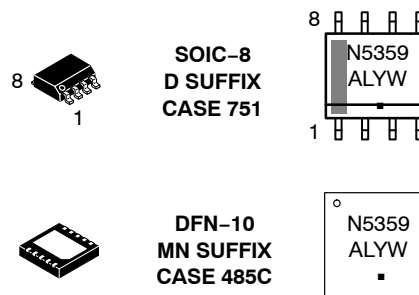

A = Assembly Location
L = Wafer Lot
Y = Year
W = Work Week
▪ = Pb-Free Package

PIN CONNECTIONS

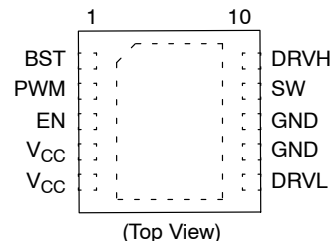
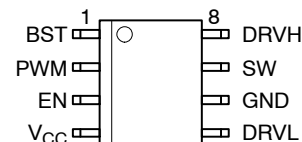

ORDERING INFORMATION

Device	Package	Shipping†
NCP5359DR2G	SOIC-8 (Pb-Free)	2500 Tape & Reel
NCP5359MNR2G	DFN-10 (Pb-Free)	3000 Tape & Reel

†For information on tape and reel specifications, including part orientation and tape sizes, please refer to our Tape and Reel Packaging Specification Brochure, BRD8011/D.

NCP5359

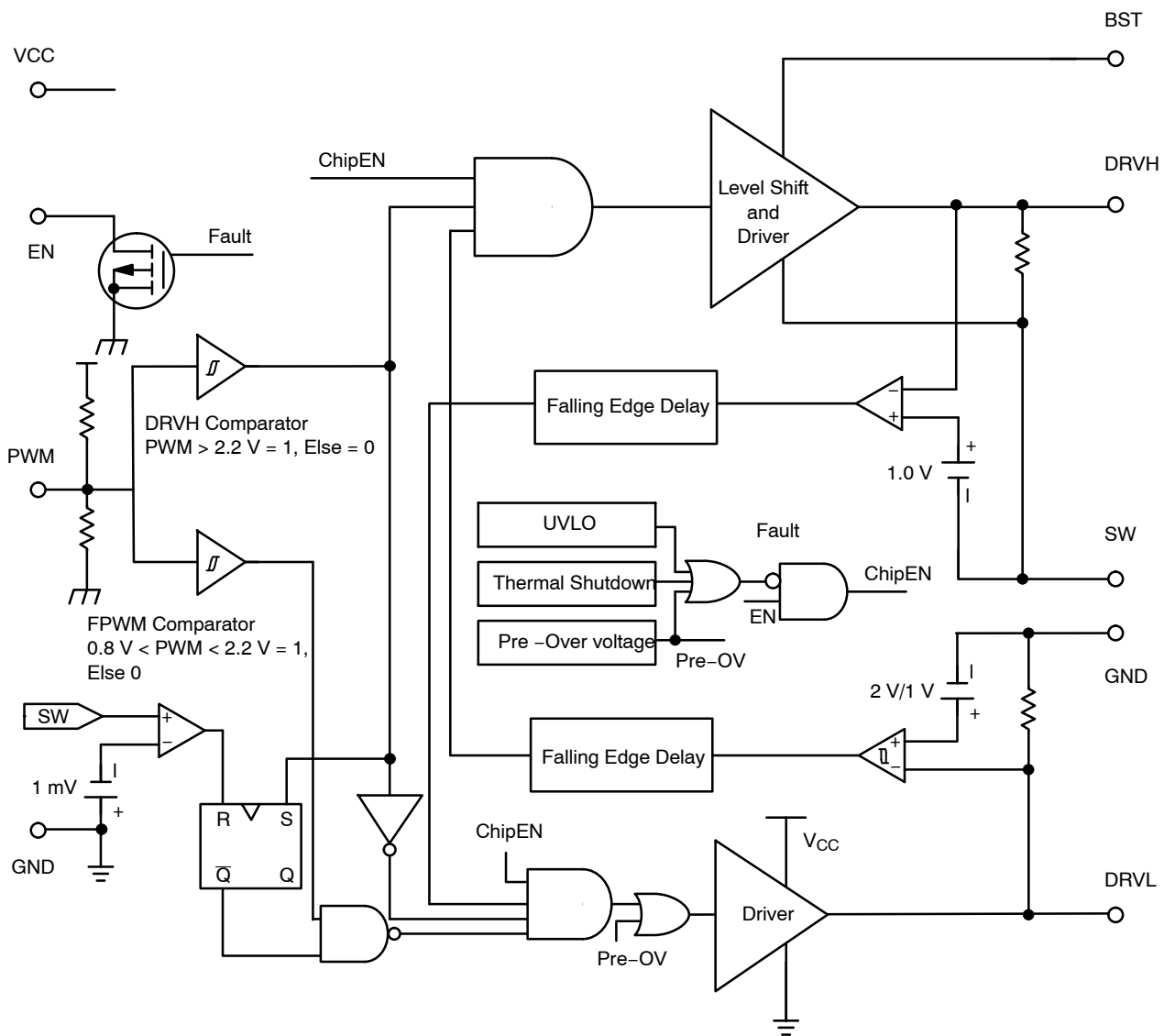

Figure 1. Internal Block Diagram

NCP5359

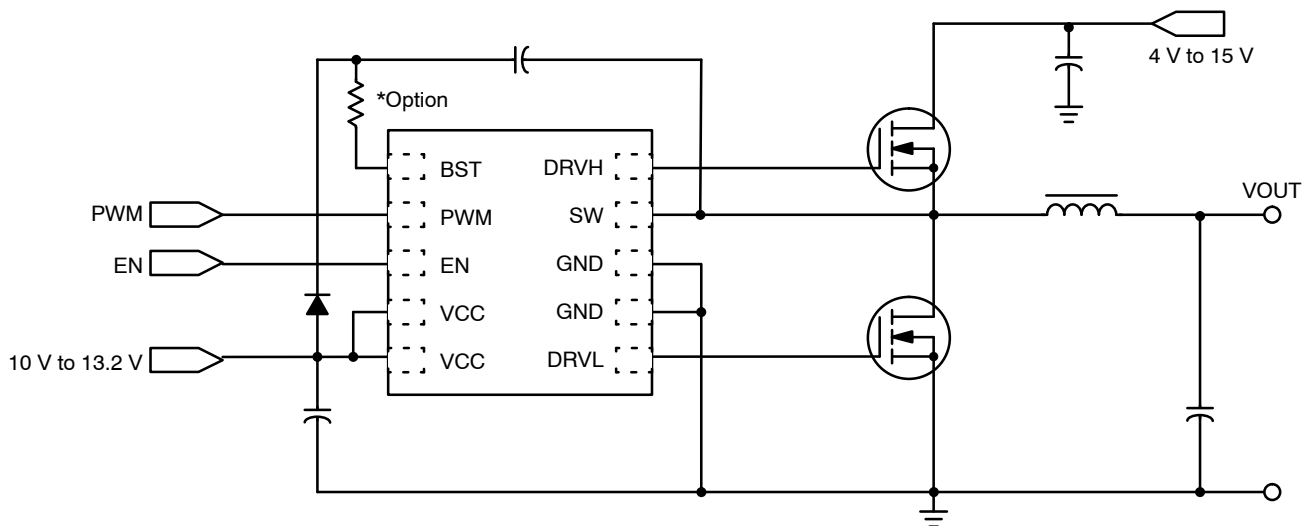

Figure 2. Typical Application

PIN DESCRIPTION

SOIC-8	DFN10	Symbol	Description
1	1	BST	Upper MOSFET Floating Bootstrap Supply Pin
2	2	PWM	PWM Input Pin When PWM voltage is higher than 2.2 V, DRVH will set to 1 and DRVL set to 0 When PWM voltage is lower than 0.8 V, DRVL will set to 1 and DRVH set to 0 When 0.8 V < PWM < 2.2 V and SW < 0, DRVL will set to 1 When 0.8 V < PWM < 2.2 V and SW > 0, DRVL will set to 0
3	3	EN	Enable Pin When OVP, TSD or UVLO has happened, the gate driver will pull the pin to low
4	4, 5	VCC	Connect to Input Power Supply 10 V to 13.2 V
5	6	DRVL	Low Side Gate Drive Output
6	7, 8	GND	Ground Pin
7	9	SW	Switch Node Pin
8	10	DRVH	High Side Gate Drive Output

NCP5359

MAXIMUM RATINGS

Rating	Symbol	Value	Unit
Thermal Characteristics, Plastic Package Thermal Resistance Junction-to-Air	$R_{\theta JA}$	178 45	°C/W
Operating Junction Temperature Range	T_J	0 to +150	°C
Operating Ambient Temperature Range	T_A	0 to +85	°C
Storage Temperature Range	T_{stg}	- 55 to +150	°C
Moisture Sensitivity Level	MSL	3 1	-

Stresses exceeding Maximum Ratings may damage the device. Maximum Ratings are stress ratings only. Functional operation above the Recommended Operating Conditions is not implied. Extended exposure to stresses above the Recommended Operating Conditions may affect device reliability.

MAXIMUM RATINGS

Pin Symbol	Pin Name	V_{MAX}	V_{MIN}
Vcc	Main Supply Voltage Input	15 V	-0.3 V
BST	Bootstrap Supply voltage	35 V wrt / GND 40 V ≤ 50 ns wrt / GND 15V wrt / SW	-0.3 V
SW	Switching Node (Bootstrap Supply Return)	35 V wrt / GND 40 V ≤ 50 ns wrt / GND	-1 VDC -10 V (200 ns) (Note 4)
DRVH	High Side Driver Output	BST + 0.3 V 35 V ≤ 50 ns wrt / GND 15V wrt / SW	-0.3 V -2 V (200 ns)
DRVL	Low Side Driver Output	Vcc + 0.3 V	-0.3 V -5 V (200 ns)
PWM	DRVH and DRVL Control Input	6 V	-0.3 V
EN	Enable Pin	6 V	-0.3 V
GND	Ground	0 V	0 V

1. Latchup Current Maximum Rating: 100 mA per JEDEC standard: JESD78.
2. Moisture Sensitivity Level (MSL): 1&3 per IPC/JEDEC standard: J-STD-020A.
3. The maximum package power dissipation limit must not be exceeded.

$$PD = \frac{T_J(\max) - T_A}{R_{\theta JA}}$$

4. Switching node negative voltage is -5 V (200 ns) at PSI mode.

NOTE: This device is ESD sensitive. Use standard ESD precautions when handling.

NCP5359

ELECTRICAL CHARACTERISTICS ($V_{CC} = 12\text{ V}$, $T_A = 0^\circ\text{C}$ to $+85^\circ\text{C}$, $V_{EN} = 5\text{ V}$ unless otherwise noted)

Characteristics	Symbol	Test Conditions	Min	Typ	Max	Units
Supply Voltage						
V_{CC} Operating Voltage	V_{CC}		10		13.2	V
Power ON Reset threshold	V_{POR}			2.8		V
Supply Current						
V_{CC} Quiescent Supply Current in Normal Operation	I_{VCC_NORM}	EN = 5 V, PWM = OSC, $F_{SW} = 100\text{ k}$ $C_{LOAD} = 0\text{ p}$		2.0	5.0	mA
V_{CC} Standby Current	I_{VCC_SBC}	EN = GND; No switching		0.5	1.0	mA
V_{CC} Quiescent Supply Current in Normal Operation	I_{BST1_normal}	PWM = +5 V, SW = 0 V		1.0	1.8	mA
	I_{BST2_normal}	PWM = GND, SW = 0 V		1.0	1.8	
BST Standby Current	I_{BST1_SD}	PWM = +5 V		0.25		mA
	I_{BST2_SD}	PWM = GND		0.25		
Undervoltage Lockout						
V_{CC} Start Threshold	$V_{CC_{TH}}$		8.2	8.7	9.5	V
V_{CC} UVLO Hysteresis	$V_{CC_{HYS}}$			1.0		V
Output Overvoltage Trip Threshold at Startup	OVPSU	Power Startup time, $V_{CC} > 9\text{ V}$. (Without trimming)	1.8		2.0	V
EN Input						
Input Voltage High	V_{EN_HI}		2.0			V
Input Voltage Low	V_{EN_LOW}				1.0	V
Hysteresis (Note 5)	V_{EN_HYS}			500		mV
Enable Pin Sink Current	I_{EN_SINK}	$V_{CC} = 5.5\text{ V}$	5.0			mA
Propagation Delay Time (Note 5)	$t_{pd_{hEN}}$			20	60	ns
	$t_{pd_{lEN}}$			20	60	
PWM Input						
DRVH Comparator Drop Threshold	V_{TH_DRVH}		2.2			V
PWM Input Self Bias Voltage	V_{PWM}		1.4	1.5	1.6	V
DRVL Comparator Rise Threshold	V_{TH_DRVL}				0.8	V
Input Current	I_{PWM}	PWM = 0 V, EN = GND		30		μA
High Side Driver						
Output Resistance, Sourcing	R_{H_TG}	$V_{BST} - V_{SW} = 12\text{ V}$		2.0	3.5	Ω
Output Resistance, Sinking	R_{L_TG}	$V_{BST} - V_{SW} = 12\text{ V}$		1.0	2.5	Ω
Transition Time (Note 7)	$t_{r_{DRVH}}$	$C_{LOAD} = 3\text{ nF}$, $V_{BST} - V_{SW} = 12\text{ V}$		16	25	ns
	$t_{f_{DRVH}}$	$C_{LOAD} = 3\text{ nF}$, $V_{BST} - V_{SW} = 12\text{ V}$		11	15	
Propagation Delay (Notes 5 & 6)	$t_{pd_{hDRVH}}$	Driving High, $C_{LOAD} = 3\text{ nF}$	10		35	ns
	$t_{pd_{lDRVH}}$	Driving Low, $C_{LOAD} = 3\text{ nF}$	8.0		30	
Low Side Driver						
Output Resistance, Sourcing	R_{H_BG}	SW = GND		2.0	3.5	Ω
Output Resistance, Sinking	R_{L_BG}	SW = V_{CC}		1.0	2.5	Ω
Transition Time (Note 7)	$t_{r_{DRVL}}$	$C_{LOAD} = 3\text{ nF}$		16	25	ns
	$t_{f_{DRVL}}$	$C_{LOAD} = 3\text{ nF}$		11	15	
Propagation Delay (Notes 5 & 6)	$t_{pd_{hDRVL}}$	Driving High, $C_{LOAD} = 3\text{ nF}$	10		35	ns
	$t_{pd_{lDRVL}}$	Driving Low, $C_{LOAD} = 3\text{ nF}$	8.0		30	
Negative Current Detector Threshold	V_{NCDT}	(Note 7)		-1.0		mV
Thermal Shutdown						
Thermal Shutdown	T_{sd}	(Note 7)	150	170		$^\circ\text{C}$
Thermal Shutdown Hysteresis	$T_{sd_{hys}}$	(Note 7)		20		$^\circ\text{C}$

5. Guaranteed by design; not tested in production.

6. For propagation delays, " t_{pdh} " refers to the specified signal going high " t_{pdl} " refers to it going low.

7. Design guaranteed.

NCP5359

Table 1. DECODER TRUTH TABLE

PWM Input	ZCD	DRV L	DRV H
Greater than 2.2 V	X	Low	High
Greater than 0.8 V, but less than 2.2 V	High (current through MOSFET is greater than 0)	High	Low
Greater than 0.8 V, but less than 2.2 V	Low (current through MOSFET is less than 0)	Low	Low
Less than 0.8 V	X	High	Low

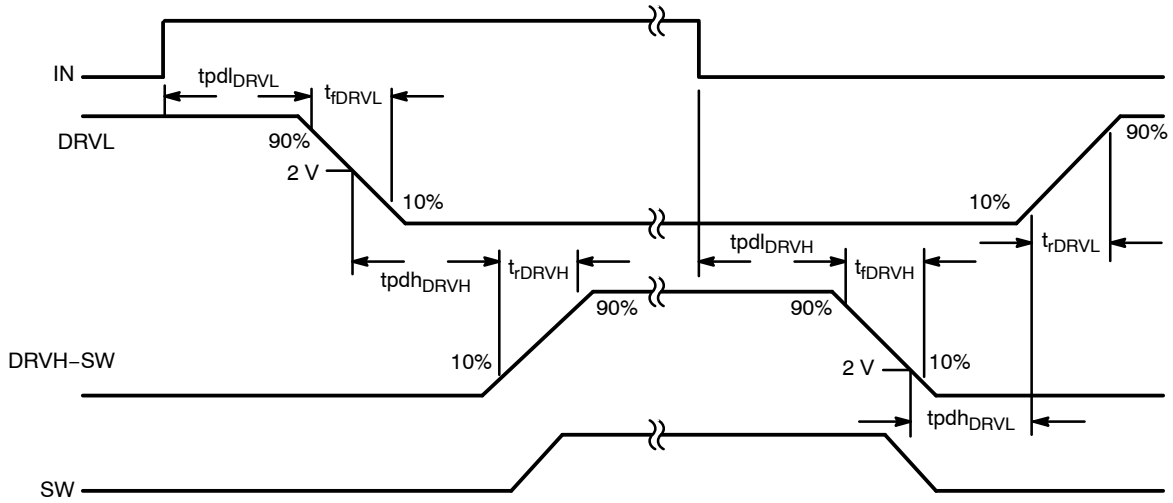

Figure 3.

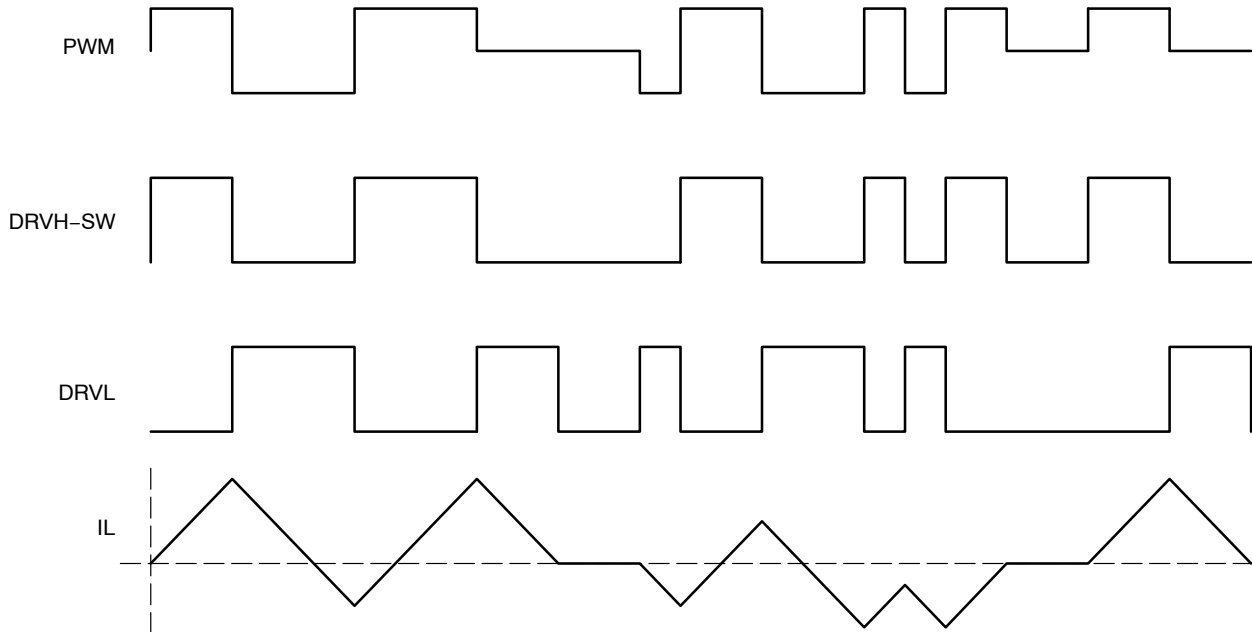

Figure 4. Timing Diagram

APPLICATION INFORMATION

The NCP5359 gate driver is a single phase MOSFET driver designed for driving two N-channel MOSFETs in a synchronous buck converter topology. This driver is compatible with the NCP3418B gate drive. This gate drives operation is similar with the NCP3418B, but has two additional new features: Bidirection fault detection and multilevel PWM input. When the gate driver works with ON Semiconductor's NCP5392 controller, it can provide a difference output logic status through multi-level PWM input. For this new feature, higher efficiency can be provided. For the bidirection fault detection function, it is used to provide a driver state information to other gate drivers and controller in a multiphase buck converter. e.g overvoltage protection (OVP) function at startup, thermal shutdown and undervoltage lockout (UVLO). This feature can provide an additional protection function for the multi-phase system when the fault condition occurs in one channel. With this additional feature, converter overall system will be more reliable and safe.

Enable Pin

The bidirection enable pin is connected with an open drain MOSFET. This pin is controlled by internal or external signal. There are three conditions will be triggered:

1. The voltage at SWN pin is higher than preset voltage at power startup.
2. The controller hits the UVLO at V_{CC} pin.
3. The controller hits the thermal shutdown.

When the internal fault has been detected, EN pin will be pull low. In this case, the drive output DRVH and DRVL will be forced low, until the fault mode remove then restart automatic.

Undervoltage Lockout

The DRVH and DRVL are held low until V_{CC} reaches 9 V during startup. The PWM signals will control the gate status when V_{CC} threshold is exceeded. If V_{CC} decreases to 3.2 V below the threshold, the output gate will be forced low until input voltage V_{CC} rises above the startup threshold.

Power ON reset

Power on reset feature is used to protect a gate driver avoid abnormal status driving the startup condition. When the initial soft-start voltage is higher than 3.2 V, the gate driver will monitor the switching node SW pin. If SW pin high than 1.9 V, bottom gate will be force to high for discharge the output capacitor. The fault mode will be latch and EN pin will force to be low, unless the driver is recycle. When input voltage is higher than 9 V, the gate driver will normal operation, top gate driver DRVH and bottom gate driver will follow the PWM signal decode to a status.

Adaptive Nonoverlap

The nonoverlap dead time control is used to avoid the shoot through damage the power MOSFETs. When the PWM signal pull high, DRVL will go low after a propagation delay, the controller will monitors the switching node (SWN) pin voltage and the gate voltage of the MOSFET to know the status of the MOSFET. When the low side MOSFET status is off an internal timer will delay turn on of the high-side MOSFET. When the PWM pull low, gate DRVH will go low after the propagation delay (t_{pd} DRVH). The time to turn off the high side MOSFET is depending on the total gate charge of the high-side MOSFET. A timer will be triggered once the high side MOSFET is turn off to delay the turn on the low-side MOSFET.

Layout Guidelines

Layout is very important thing for design a DC-DC converter. Bootstrap capacitor and V_{CC} capacitor are most critical items, it should be placed as close as to the driver IC. Another item is using a GND plane. Ground plane can provide a good return path for gate drives for reducing the ground noise. Therefore GND pin should be directly connected to the ground plane and close to the low-side MOSFET source pin. Also, the gate drive trace should be considered. The gate drives has a high di/dt when switching, therefore a minimized gate drives trace can reduce the di/dv, raise and fall time for reduce the switching loss.

NCP5359

PACKAGE DIMENSIONS

DFN10, 3x3
MN SUFFIX
CASE 485C-01
ISSUE B

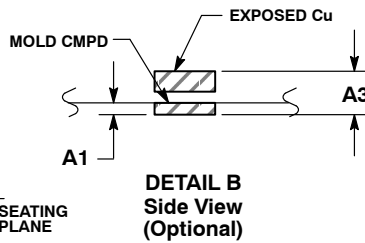
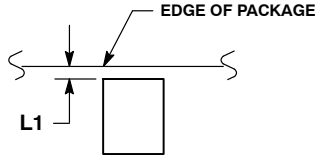
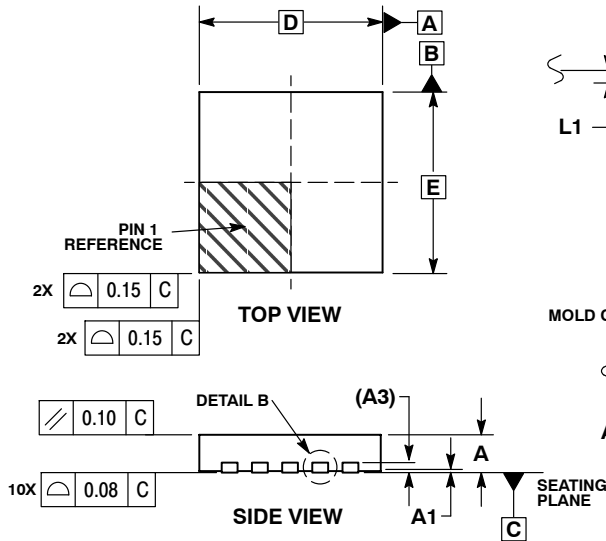

NOTES:

1. DIMENSIONING AND TOLERANCING PER ASME Y14.5M, 1994.
2. CONTROLLING DIMENSION: MILLIMETERS.
3. DIMENSION b APPLIES TO PLATED TERMINAL AND IS MEASURED BETWEEN 0.25 AND 0.30 MM FROM TERMINAL.
4. COPLANARITY APPLIES TO THE EXPOSED PAD AS WELL AS THE TERMINALS.
5. TERMINAL b MAY HAVE MOLD COMPOUND MATERIAL ALONG SIDE EDGE. MOLD FLASHING MAY NOT EXCEED 30 MICRONS ONTO BOTTOM SURFACE OF TERMINAL b.
6. DETAILS A AND B SHOW OPTIONAL VIEWS FOR END OF TERMINAL LEAD AT EDGE OF PACKAGE.

MILLIMETERS		
DIM	MIN	MAX
A	0.80	1.00
A1	0.00	0.05
A3	0.20	REF
b	0.18	0.30
D	3.00	BSC
D2	2.40	2.60
E	3.00	BSC
E2	1.70	1.90
e	0.50	BSC
K	0.19	TYP
L	0.35	0.45
L1	0.00	0.03

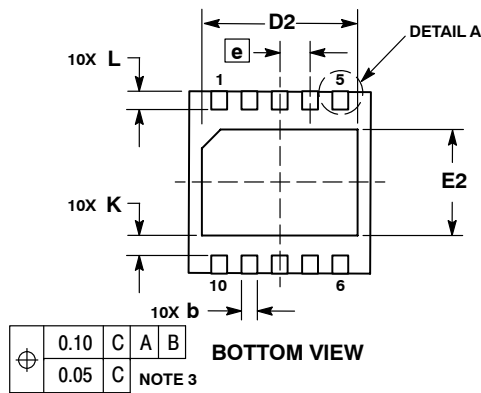

SOLDERING FOOTPRINT*

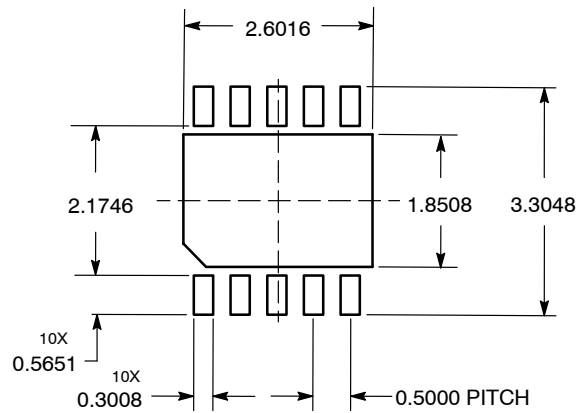

DIMENSIONS: MILLIMETERS

*For additional information on our Pb-Free strategy and soldering details, please download the ON Semiconductor Soldering and Mounting Techniques Reference Manual, SOLDERRM/D.

NCP5359

PACKAGE DIMENSIONS

SOIC-8
CASE 751-07
ISSUE AJ

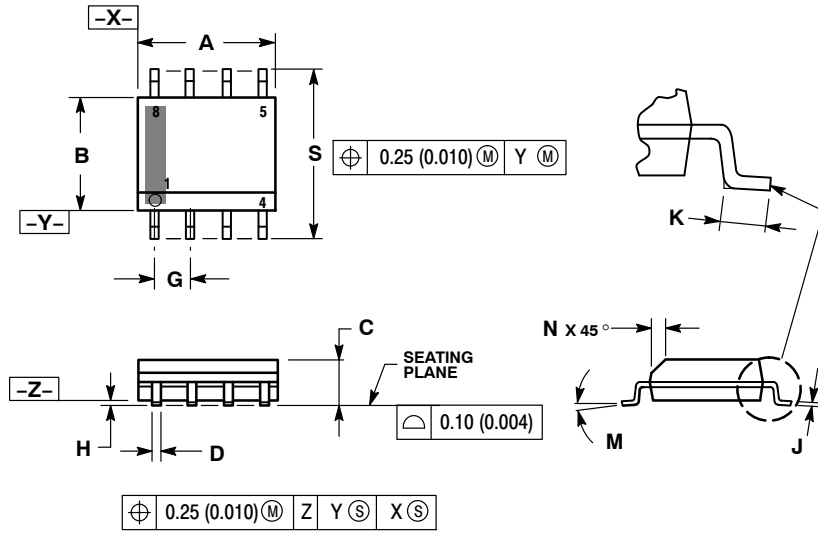

NOTES:

1. DIMENSIONING AND TOLERANCING PER ANSI Y14.5M, 1982.
2. CONTROLLING DIMENSION: MILLIMETER.
3. DIMENSION A AND B DO NOT INCLUDE MOLD PROTRUSION.
4. MAXIMUM MOLD PROTRUSION 0.15 (0.006) PER SIDE.
5. DIMENSION D DOES NOT INCLUDE DAMBAR PROTRUSION. ALLOWABLE DAMBAR PROTRUSION SHALL BE 0.127 (0.005) TOTAL IN EXCESS OF THE D DIMENSION AT MAXIMUM MATERIAL CONDITION.
6. 751-01 THRU 751-06 ARE OBSOLETE. NEW STANDARD IS 751-07.

DIM	MILLIMETERS		INCHES	
	MIN	MAX	MIN	MAX
A	4.80	5.00	0.189	0.197
B	3.80	4.00	0.150	0.157
C	1.35	1.75	0.053	0.069
D	0.33	0.51	0.013	0.020
G	1.27 BSC		0.050 BSC	
H	0.10	0.25	0.004	0.010
J	0.19	0.25	0.007	0.010
K	0.40	1.27	0.016	0.050
M	0°	8°	0°	8°
N	0.25	0.50	0.010	0.020
S	5.80	6.20	0.228	0.244

SOLDERING FOOTPRINT*

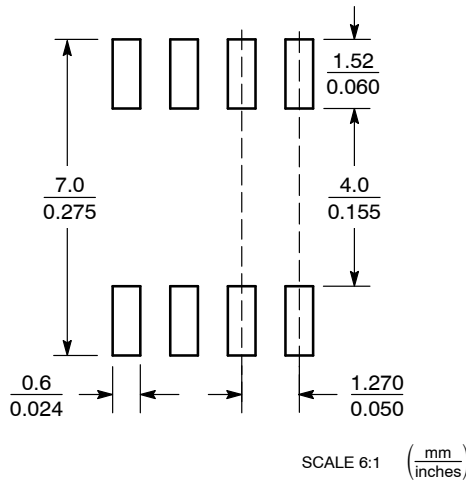

*For additional information on our Pb-Free strategy and soldering details, please download the ON Semiconductor Soldering and Mounting Techniques Reference Manual, SOLDERRM/D.

ON Semiconductor and are registered trademarks of Semiconductor Components Industries, LLC (SCILLC). SCILLC reserves the right to make changes without further notice to any products herein. SCILLC makes no warranty, representation or guarantee regarding the suitability of its products for any particular purpose, nor does SCILLC assume any liability arising out of the application or use of any product or circuit, and specifically disclaims any and all liability, including without limitation special, consequential or incidental damages. "Typical" parameters which may be provided in SCILLC data sheets and/or specifications can and do vary in different applications and actual performance may vary over time. All operating parameters, including "Typicals" must be validated for each customer application by customer's technical experts. SCILLC does not convey any license under its patent rights nor the rights of others. SCILLC products are not designed, intended, or authorized for use as components in systems intended for surgical implant into the body, or other applications intended to support or sustain life, or for any other application in which the failure of the SCILLC product could create a situation where personal injury or death may occur. Should Buyer purchase or use SCILLC products for any such unintended or unauthorized application, Buyer shall indemnify and hold SCILLC and its officers, employees, subsidiaries, affiliates, and distributors harmless against all claims, costs, damages, and expenses, and reasonable attorney fees arising out of, directly or indirectly, any claim of personal injury or death associated with such unintended or unauthorized use, even if such claim alleges that SCILLC was negligent regarding the design or manufacture of the part. SCILLC is an Equal Opportunity/Affirmative Action Employer. This literature is subject to all applicable copyright laws and is not for resale in any manner.

PUBLICATION ORDERING INFORMATION

LITERATURE FULFILLMENT:
Literature Distribution Center for ON Semiconductor
P.O. Box 5163, Denver, Colorado 80217 USA
Phone: 303-675-2175 or 800-344-3860 Toll Free USA/Canada
Fax: 303-675-2176 or 800-344-3867 Toll Free USA/Canada
Email: orderlit@onsemi.com

N. American Technical Support: 800-282-9855 Toll Free USA/Canada
Europe, Middle East and Africa Technical Support:
Phone: 421 33 790 2910
Japan Customer Focus Center
Phone: 81-3-5773-3850

ON Semiconductor Website: www.onsemi.com
Order Literature: <http://www.onsemi.com/orderlit>

For additional information, please contact your local Sales Representative

Looking for pricing, stock, or lifecycle information?

Click below to explore more details on WIN SOURCE:

 [View NCP5359MNR2G on WIN SOURCE](#)

 [ON Semiconductor](#) Information

Optimize Your Supply Chain with WIN SOURCE Solutions

-  Global Sourcing Solution
-  Obsolete Management
-  Cost Control Management
-  Shortage Management
-  Alternative Solution
-  Excess Inventory Management