



**THE DATASHEET OF
SN74HSTL16919DGGR**



SN74HSTL16919

9-BIT TO 18-BIT HSTL-TO-LVTTL MEMORY ADDRESS LATCH WITH INPUT PULLUP RESISTORS

SCES348 – MARCH 2001

- Member of Texas Instruments' Widebus™ Family
- Inputs Meet JEDEC HSTL Std JESD 8-6, and Outputs Meet Level III Specifications
- 10-kΩ Pullup Resistor on Data and \overline{LE} Inputs
- Latch-Up Performance Exceeds 100 mA Per JESD 78, Class II
- ESD Protection Exceeds JESD 22
 - 2000-V Human-Body Model (A114-A)
 - 200-V Machine Model (A115-A)
 - 1000-V Charged-Device Model (C101)

description

This 9-bit to 18-bit D-type latch is designed for 3.15-V to 3.45-V V_{CC} operation. The D inputs accept HSTL levels and the Q outputs provide LVTTL levels.

The SN74HSTL16919 is particularly suitable for driving an address bus to two banks of memory. Each bank of nine outputs is controlled with its own latch-enable (\overline{LE}) input.

Each of the nine D inputs is tied to the inputs of two D-type latches that provide true data (Q) at the outputs. While \overline{LE} is low, the Q outputs of the corresponding nine latches follow the D inputs. When \overline{LE} is taken high, the Q outputs are latched at the levels set up at the D inputs.

To ensure low I_{CC} during power up or power down, 10-kΩ pullup resistors are included on the D and \overline{LE} inputs to ensure a differential voltage relative to V_{REF} . V_{REF} must be applied prior to or at the same time as V_{CC} , or V_{REF} must be pulled down to ground.

DGG PACKAGE
(TOP VIEW)

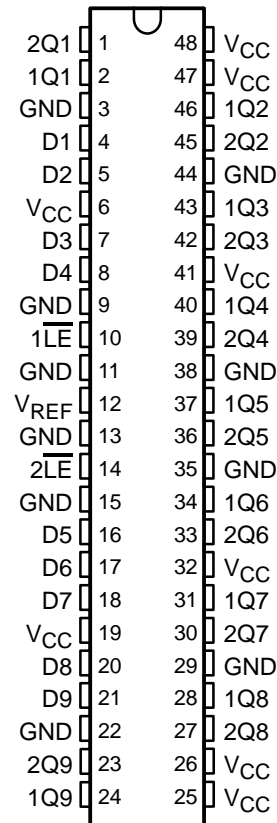

ORDERING INFORMATION

T _A	PACKAGE†	ORDERABLE PART NUMBER	TOP-SIDE MARKING
0°C to 70°C	TSSOP – DGG Tape and reel	SN74HSTL16919DGGR	HSTL16919

† Package drawings, standard packing quantities, thermal data, symbolization, and PCB design guidelines are available at www.ti.com/sc/package.



Please be aware that an important notice concerning availability, standard warranty, and use in critical applications of Texas Instruments semiconductor products and disclaimers thereto appears at the end of this data sheet.

Widebus is a trademark of Texas Instruments.

PRODUCTION DATA information is current as of publication date. Products conform to specifications per the terms of Texas Instruments standard warranty. Production processing does not necessarily include testing of all parameters.



Copyright © 2001, Texas Instruments Incorporated

SN74HSTL16919
9-BIT TO 18-BIT HSTL-TO-LVTTL MEMORY ADDRESS LATCH
WITH INPUT PULLUP RESISTORS

SCES348 – MARCH 2001

FUNCTION TABLE

INPUTS		OUTPUT
LE	D	Q
L	H	H
L	L	L
H	X	Q ₀ [†]

[†] Output level before the indicated steady-state input conditions were established

logic diagram (positive logic)

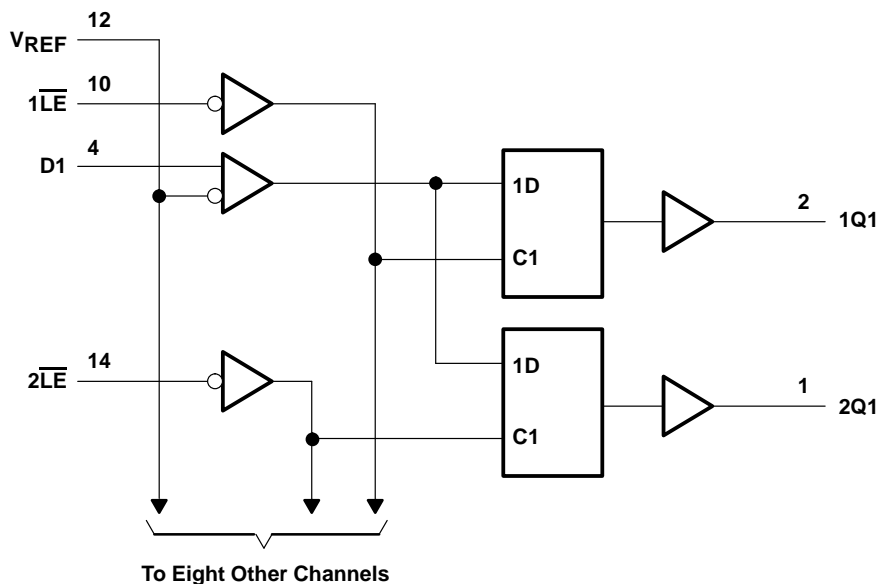

absolute maximum ratings over operating free-air temperature range (unless otherwise noted)[‡]

Supply voltage range, V_{CC}	-0.5 V to 4.6 V
Input voltage range, V_I (see Note 1)	-0.5 V to $V_{CC} + 0.5$ V
Output voltage range, V_O (see Note 1)	-0.5 V to $V_{CC} + 0.5$ V
Input clamp current, I_{IK} ($V_I < 0$)	-50 mA
Output clamp current, I_{OK} ($V_O < 0$ or $V_O > V_{CC}$)	±50 mA
Continuous output current, I_O ($V_O = 0$ to V_{CC})	±50 mA
Continuous current through each V_{CC} or GND	±100 mA
Package thermal impedance, θ_{JA} (see Note 2)	89°C/W
Storage temperature range, T_{Stg}	-65°C to 150°C

[‡] Stresses beyond those listed under “absolute maximum ratings” may cause permanent damage to the device. These are stress ratings only, and functional operation of the device at these or any other conditions beyond those indicated under “recommended operating conditions” is not implied. Exposure to absolute-maximum-rated conditions for extended periods may affect device reliability.

- NOTES: 1. The input and output negative-voltage ratings may be exceeded if the input and output clamp-current ratings are observed.
 2. The package thermal impedance is calculated in accordance with JESD 51-7.



SN74HSTL16919

9-BIT TO 18-BIT HSTL-TO-LVTTL MEMORY ADDRESS LATCH WITH INPUT PULLUP RESISTORS

SCES348 – MARCH 2001

recommended operating conditions (see Note 3)

		MIN	NOM	MAX	UNIT
V _{CC}	Supply voltage	3.15		3.45	V
V _{REF}	Reference voltage	0.68	0.75	0.9	V
V _I	Input voltage	0		1.5	V
V _{IH}	AC high-level input voltage	All inputs		V _{REF} +200 mV	V
V _{IL}	AC low-level input voltage	All inputs		V _{REF} -200 mV	V
V _{IH}	DC high-level input voltage	All inputs		V _{REF} +100 mV	V
V _{IL}	DC low-level input voltage	All inputs		V _{REF} -100 mV	V
I _{OH}	High-level output current			-24	mA
I _{OL}	Low-level output current			24	mA
T _A	Operating free-air temperature	0		70	°C

NOTE 3: All unused inputs of the device must maintain a minimum differential voltage of 100 mV between data inputs and V_{REF} to ensure proper device operation. Refer to the TI application report, *Implications of Slow or Floating CMOS Inputs*, literature number SCBA004.

electrical characteristics over recommended operating free-air temperature range (unless otherwise noted)

PARAMETER		TEST CONDITIONS		MIN	TYP†	MAX	UNIT
V _{IK}		V _{CC} = 3.15 V,	I _I = -18 mA			-1.2	V
V _{OH}		V _{CC} = 3.15 V,	I _{OH} = -24 mA	2.4			V
V _{OL}		V _{CC} = 3.15 V,	I _{OL} = 24 mA			0.5	V
I _I	Control inputs	V _{CC} = 3.45 V	V _I = 0 or 1.5 V			-500	μA
	Data inputs		V _I = 0 or 1.5 V			-500	
	V _{REF}		V _{REF} = 0.68 V or 0.9 V			90	
I _{CC}		V _{CC} = 3.45 V,	V _I = 0 or 1.5 V		50	100	mA
C _i	Control inputs	V _{CC} = 0 or 3.3 V,	V _I = 0 or 3.3 V		2.5		pF
	Data inputs	V _{CC} = 0 or 3.3 V,	V _I = 0 or 3.3 V		2.5		
C _o	Outputs	V _{CC} = 0,	V _O = 0		2.5		pF

† All typical values are at V_{CC} = 3.3 V, T_A = 25°C.

timing requirements over recommended ranges of supply voltage and operating free-air temperature (unless otherwise noted) (see Figure 1)

		V _{CC} = 3.3 V ± 0.15 V		UNIT	
		MIN	MAX		
t _w	Pulse duration, \overline{LE} low	3		ns	
t _{su}	Setup time, D before \overline{LE} ↑	2		ns	
t _h	Hold time		D after \overline{LE} ↑	1	ns
t _{ldr} ‡	Data race condition time		D after \overline{LE} ↓	0	ns

‡ This is the maximum time after \overline{LE} switches low that the data input can return to the latched state from the opposite state without producing a glitch on the output.



SN74HSTL16919
9-BIT TO 18-BIT HSTL-TO-LVTTL MEMORY ADDRESS LATCH
WITH INPUT PULLUP RESISTORS

SCES348 – MARCH 2001

switching characteristics over recommended operating free-air temperature range, $V_{REF} = 0.75 V$

PARAMETER	FROM (INPUT)	TO (OUTPUT)	$V_{CC} = 3.3 V$ $\pm 0.15 V$		UNIT
			MIN	MAX	
t_{pd}	D	Q	1.9	3.5	ns
	\overline{LE}		1.9	4.3	

simultaneous switching characteristics over recommended operating free-air temperature range, $V_{REF} = 0.75 V$ †

PARAMETER	FROM (INPUT)	TO (OUTPUT)	$V_{CC} = 3.3 V$ $\pm 0.15 V$		UNIT
			MIN	MAX	
t_{pd}	D	Q	1.9	4.5	ns
	\overline{LE}		1.9	5.3	

† All outputs switching.



SN74HSTL16919
**9-BIT TO 18-BIT HSTL-TO-LVTTL MEMORY ADDRESS LATCH
 WITH INPUT PULLUP RESISTORS**

SCES348 – MARCH 2001

PARAMETER MEASUREMENT INFORMATION

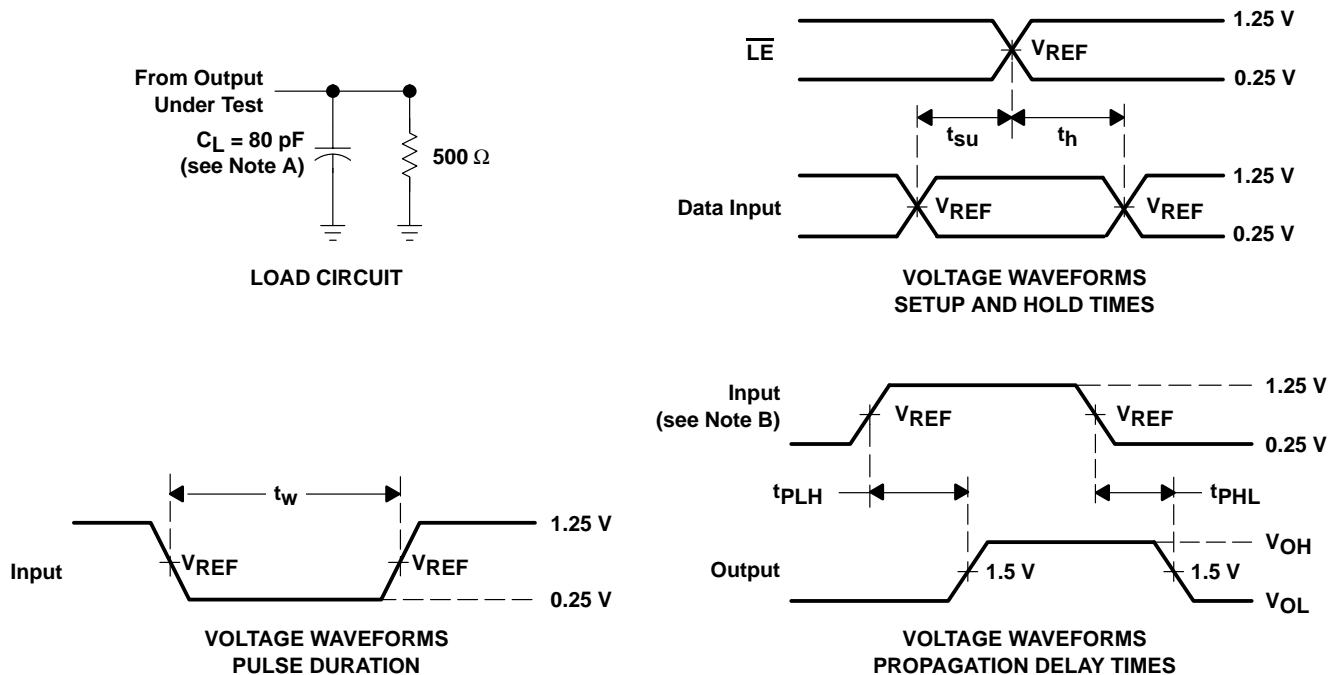

- NOTES: A. C_L includes probe and jig capacitance.
 B. All input pulses are supplied by generators having the following characteristics: $PRR \leq 10$ MHz, $Z_O = 50 \Omega$, $t_r \leq 1$ ns, $t_f \leq 1$ ns.
 C. The outputs are measured one at a time with one transition per measurement.
 D. t_{PHL} and t_{PLH} are the same as t_{pd} .

Figure 1. Load Circuit and Voltage Waveforms

IMPORTANT NOTICE

Texas Instruments and its subsidiaries (TI) reserve the right to make changes to their products or to discontinue any product or service without notice, and advise customers to obtain the latest version of relevant information to verify, before placing orders, that information being relied on is current and complete. All products are sold subject to the terms and conditions of sale supplied at the time of order acknowledgment, including those pertaining to warranty, patent infringement, and limitation of liability.

TI warrants performance of its products to the specifications applicable at the time of sale in accordance with TI's standard warranty. Testing and other quality control techniques are utilized to the extent TI deems necessary to support this warranty. Specific testing of all parameters of each device is not necessarily performed, except those mandated by government requirements.

Customers are responsible for their applications using TI components.

In order to minimize risks associated with the customer's applications, adequate design and operating safeguards must be provided by the customer to minimize inherent or procedural hazards.

TI assumes no liability for applications assistance or customer product design. TI does not warrant or represent that any license, either express or implied, is granted under any patent right, copyright, mask work right, or other intellectual property right of TI covering or relating to any combination, machine, or process in which such products or services might be or are used. TI's publication of information regarding any third party's products or services does not constitute TI's approval, license, warranty or endorsement thereof.

Reproduction of information in TI data books or data sheets is permissible only if reproduction is without alteration and is accompanied by all associated warranties, conditions, limitations and notices. Representation or reproduction of this information with alteration voids all warranties provided for an associated TI product or service, is an unfair and deceptive business practice, and TI is not responsible nor liable for any such use.

Resale of TI's products or services with statements different from or beyond the parameters stated by TI for that product or service voids all express and any implied warranties for the associated TI product or service, is an unfair and deceptive business practice, and TI is not responsible nor liable for any such use.

Also see: [Standard Terms and Conditions of Sale for Semiconductor Products](http://www.ti.com/sc/docs/stdterms.htm). www.ti.com/sc/docs/stdterms.htm

Mailing Address:

Texas Instruments
Post Office Box 655303
Dallas, Texas 75265

Looking for pricing, stock, or lifecycle information?

Click below to explore more details on WIN SOURCE:

 [View SN74HSTL16919DGGR on WIN SOURCE](#)

 [Texas Instruments](#) Information

Optimize Your Supply Chain with WIN SOURCE Solutions

-  Global Sourcing Solution
-  Obsolete Management
-  Cost Control Management
-  Shortage Management
-  Alternative Solution
-  Excess Inventory Management