

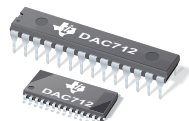

**THE DATASHEET OF
DAC712UKG4**





16-BIT DIGITAL-TO-ANALOG CONVERTER with 16-Bit Bus Interface

FEATURES

- **HIGH-SPEED, 16-BIT PARALLEL DOUBLE-BUFFERED INTERFACE**
- **VOLTAGE OUTPUT: $\pm 10\text{V}$**
- **13-, 14-, AND 15-BIT LINEARITY GRADES**
- **16-BIT MONOTONIC OVER TEMPERATURE (L GRADE)**
- **POWER DISSIPATION: 600mW max**
- **GAIN AND OFFSET ADJUST: Convenient for Auto-Cal D/A Converters**
- **28-LEAD DIP AND SOIC PACKAGES**

DESCRIPTION

The DAC712 is a complete 16-bit resolution digital-to-analog (D/A) converter with 16 bits of monotonicity over temperature.

The DAC712 has a precision $+10\text{V}$ temperature-compensated voltage reference, $\pm 10\text{V}$ output amplifier, and 16-bit port bus interface.

The digital interface is fast, 60ns minimum write pulse width, double-buffered, and has a CLEAR function that resets the analog output to bipolar zero.

GAIN and OFFSET adjustment inputs are arranged so that they can be easily trimmed by external D/A converters as well as by potentiometers.

The DAC712 is available in two linearity error performance grades: $\pm 4\text{LSB}$ and $\pm 2\text{LSB}$, and three differential linearity grades: $\pm 4\text{LSB}$, $\pm 2\text{LSB}$, and $\pm 1\text{LSB}$. The DAC712 is specified at power-supply voltages of $\pm 12\text{V}$ and $\pm 15\text{V}$.

The DAC712 is packaged in a 28-pin, 0.3" wide plastic DIP and in a 28-lead, wide-body plastic SOIC. The DAC712P, U, PB, and UB are specified over the -40°C to $+85^\circ\text{C}$ temperature range and the DAC712PK, UK, PL, and UL are specified over the 0°C to $+70^\circ\text{C}$ range.

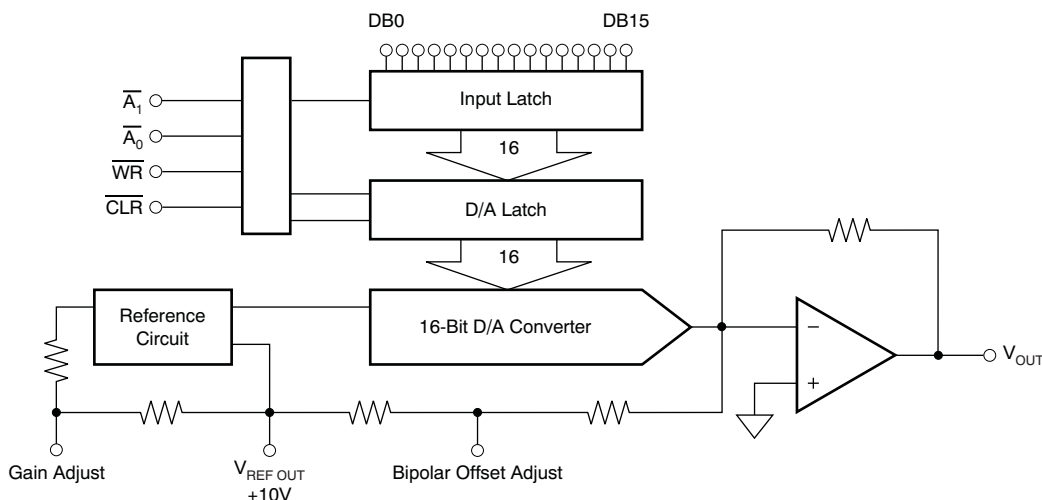

Please be aware that an important notice concerning availability, standard warranty, and use in critical applications of Texas Instruments semiconductor products and disclaimers thereto appears at the end of this data sheet.

All trademarks are the property of their respective owners.



This integrated circuit can be damaged by ESD. Texas Instruments recommends that all integrated circuits be handled with appropriate precautions. Failure to observe proper handling and installation procedures can cause damage.

ESD damage can range from subtle performance degradation to complete device failure. Precision integrated circuits may be more susceptible to damage because very small parametric changes could cause the device not to meet its published specifications.

PACKAGE/ORDERING INFORMATION⁽¹⁾

PRODUCT	LINEARITY ERROR MAX AT +25°C	DIFFERENTIAL LINEARITY ERROR MAX AT +25°C	PACKAGE-LEAD	PACKAGE DESIGNATOR	SPECIFIED TEMPERATURE RANGE
DAC712P	±4LSB	±4LSB	PDIP-28	NT	-40°C to +85°C
DAC712U	±4LSB	±4LSB	SOIC-28	DW	-40°C to +85°C
DAC712PB	±2LSB	±2LSB	PDIP-28	NT	-40°C to +85°C
DAC712UB	±2LSB	±2LSB	SOIC-28	DW	-40°C to +85°C
DAC712PK	±2LSB	±2LSB	PDIP-28	NT	0°C to +70°C
DAC712UK	±2LSB	±2LSB	SOIC-28	DW	0°C to +70°C
DAC712PL	±2LSB	±1LSB	PDIP-28	NT	0°C to +70°C
DAC712UL	±2LSB	±1LSB	SOIC-28	DW	0°C to +70°C

(1) For the most current package and ordering information see the Package Option Addendum at the end of this document, or see the TI web site at www.ti.com.

ABSOLUTE MAXIMUM RATINGS⁽¹⁾

	DAC712	UNIT
+V _{CC} to COMMON	0, +17	V
-V _{CC} to COMMON	0, -17	V
+V _{CC} to -V _{CC}	34	V
Digital Inputs to COMMON	-1 to +V _{CC} - 0.7	V
External Voltage Applied to BPO and Range Resistors	±V _{CC}	V
V _{REF OUT}	Indefinite Short to COMMON	
V _{OUT}	Indefinite Short to COMMON	
Power Dissipation	750	mW
Storage Temperature Range	-60 to +150	°C

(1) Stresses above these ratings may cause permanent damage. Exposure to absolute maximum conditions for extended periods may degrade device reliability. These are stress ratings only, and functional operation of the device at these or any other conditions beyond those specified is not implied.

TRUTH TABLE

$\overline{A_0}$	$\overline{A_1}$	\overline{WR}	\overline{CLR}	DESCRIPTION
0	1	1 → 0 → 1	1	Load Input Latch
1	0	1 → 0 → 1	1	Load D/A Latch
1	1	1 → 0 → 1	1	No Change
0	0	0	1	Latches Transparent
X	X	1	1	No Change
X	X	X	0	Reset D/A Latch

ELECTRICAL CHARACTERISTICS: DAC712P, U, PB, UB

 At $T_A = +25^\circ\text{C}$, $+V_{CC} = +12\text{V}$ and $+15\text{V}$, and $-V_{CC} = -12\text{V}$ and -15V , unless otherwise noted.

PARAMETER	TEST CONDITIONS	DAC712P, U			DAC712PB, UB ⁽¹⁾			UNIT
		MIN	TYP	MAX	MIN	TYP	MAX	
INPUT								
RESOLUTION								
Resolution			16					Bits
DIGITAL INPUTS								
Input Code		Binary Twos Complement						
Logic Levels ⁽²⁾								
V_{IH}		+2.0		$+V_{CC} - 1.4$				V
V_{IL}		0		+0.8				V
I_{IH} ($V_I = +2.7\text{V}$)				±10				µA
I_{IL} ($V_I = +0.4\text{V}$)				±10				µA
TRANSFER CHARACTERISTICS								
ACCURACY								
Linearity Error				±4			±2	LSB
T_{MIN} to T_{MAX}				±8			±4	LSB
Differential Linearity Error				±4			±2	LSB
T_{MIN} to T_{MAX}				±8			±4	LSB
Monotonicity Over Temperature		13			14			Bits
Gain Error ⁽³⁾				±0.1				%
T_{MIN} to T_{MAX}				±0.2			±0.15	%
Bipolar Zero Error ⁽³⁾				±0.1				% FSR ⁽⁴⁾
				±20				mV
T_{MIN} to T_{MAX}				±0.2			±0.15	% FSR
				±40			±30	mV
Power-Supply Sensitivity of Full-Scale				±0.003				% FSR/% V_{CC}
				±30				ppm FSR/% V_{CC}
DYNAMIC PERFORMANCE								
Settling Time (to ±0.003%FSR, 5kΩ 500pF Load) ⁽⁵⁾								
20V Output Step			6				10	µs
1LSB Output Step ⁽⁶⁾			4					µs
Output Slew Rate			10					V/µs
Total Harmonic Distortion + Noise								
0dB, 1001Hz, $f_S = 100\text{kHz}$			0.005					%
-20dB, 1001Hz, $f_S = 100\text{kHz}$			0.03					%
-60dB, 1001Hz, $f_S = 100\text{kHz}$			3.0					%
SINAD								
1001Hz, $f_S = 100\text{kHz}$			87					dB
Digital Feedthrough ⁽⁶⁾			2					nV-s
Digital-to-Analog Glitch Impulse ⁽⁶⁾			15					nV-s
Output Noise Voltage (Includes Reference)			120					nV/√Hz

(1) Shaded cells indicate same specification as the DAC712P, U grade.

(2) Digital inputs are TTL- and +5V CMOS-compatible over the specified temperature range.

(3) Errors externally adjustable to zero.

(4) FSR means Full-Scale Range. For example, for a ±10V output, FSR = 20V.

(5) Maximum represents the 3σ limit. Not 100% tested for this parameter.

(6) For the worst-case code changes: FFFFh to 0000h and 0000h to FFFFh. These are binary twos complement (BTC) codes.

ELECTRICAL CHARACTERISTICS: DAC712P, U, PB, UB (continued)

At $T_A = +25^\circ\text{C}$, $+V_{CC} = +12\text{V}$ and $+15\text{V}$, and $-V_{CC} = -12\text{V}$ and -15V , unless otherwise noted.

PARAMETER	TEST CONDITIONS	DAC712P, U			DAC712PB, UB ⁽¹⁾			UNIT
		MIN	TYP	MAX	MIN	TYP	MAX	
ANALOG OUTPUT								
Output Voltage Range								
+ V_{CC} , - $V_{CC} = \pm 11.4\text{V}$		± 10						V
Output Current		± 5						mA
Output Impedance			0.1					Ω
Short-Circuit to ACOM, Duration			Indefinite					
REFERENCE VOLTAGE								
Voltage		+9.975	+10.000	+10.025				V
T_{MIN} to T_{MAX}		+9.960		+10.040				V
Output Resistance			1					Ω
Source Current		2						mA
Short-Circuit to ACOM, Duration			Indefinite					
POWER-SUPPLY REQUIREMENTS								
Voltage								
+ V_{CC}		+11.4	+15	+16.5				V
- V_{CC}		-11.4	-15	-16.5				V
Current (No Load, $\pm 15\text{V}$ Supplies)								
+ V_{CC}			13	15				mA
- V_{CC}			22	25				mA
Power Dissipation ⁽⁷⁾			525	600				mW
TEMPERATURE RANGES								
Specified Temperature Range (All Grades)		-40		+85				$^\circ\text{C}$
Storage Temperature Range		-60		+150				$^\circ\text{C}$
Thermal Coefficient, θ_{JA}								
DIP Package			75					$^\circ\text{C/W}$
SOIC Package			75					$^\circ\text{C/W}$

(7) Typical supply voltages times maximum currents.

ELECTRICAL CHARACTERISTICS: DAC712PK, UK, PL, UL

 At $T_A = +25^\circ\text{C}$, $+V_{CC} = +12\text{V}$ and $+15\text{V}$, and $-V_{CC} = -12\text{V}$ and -15V , unless otherwise noted.

PARAMETER	TEST CONDITIONS	DAC712PK, UK			DAC712PL, UL ⁽¹⁾			UNIT
		MIN	TYP	MAX	MIN	TYP	MAX	
INPUT								
RESOLUTION								
Resolution			16					Bits
DIGITAL INPUTS								
Input Code		Binary Twos Complement						
Logic Levels ⁽²⁾								
V_{IH}		+2.0		$+V_{CC} - 1.4$				V
V_{IL}		0		+0.8				V
I_{IH} ($V_I = +2.7\text{V}$)				± 10				μA
I_{IL} ($V_I = +0.4\text{V}$)				± 10				μA
TRANSFER CHARACTERISTICS								
ACCURACY								
Linearity Error				± 2				LSB
T_{MIN} to T_{MAX}				± 2				LSB
Differential Linearity Error				± 2			± 1	LSB
T_{MIN} to T_{MAX}				± 2			± 1	LSB
Monotonicity Over Temperature		15			16			Bits
Gain Error ⁽³⁾				± 0.1				%
T_{MIN} to T_{MAX}				± 0.15			± 0.2	%
Bipolar Zero Error ⁽³⁾				± 0.1				% FSR ⁽⁴⁾
				± 20				mV
T_{MIN} to T_{MAX}				± 0.15				% FSR
				± 30				mV
Power-Supply Sensitivity of Full-Scale				± 0.003				% FSR/% V_{CC}
				± 30				ppm FSR/% V_{CC}
DYNAMIC PERFORMANCE								
Settling Time (to $\pm 0.003\%$ FSR, $5\text{k}\Omega \parallel 500\text{pF}$ Load) ⁽⁵⁾								
20V Output Step			6	10				μs
1LSB Output Step ⁽⁶⁾			4					μs
Output Slew Rate			10					$\text{V}/\mu\text{s}$
Total Harmonic Distortion + Noise								
0dB, 1001Hz, $f_S = 100\text{kHz}$			0.005					%
-20dB, 1001Hz, $f_S = 100\text{kHz}$			0.03					%
-60dB, 1001Hz, $f_S = 100\text{kHz}$			3.0					%
SINAD								
1001Hz, $f_S = 100\text{kHz}$			87					dB
Digital Feedthrough ⁽⁶⁾			2					nV-s
Digital-to-Analog Glitch Impulse ⁽⁶⁾			15					nV-s
Output Noise Voltage (Includes Reference)			120					$\text{nV}/\sqrt{\text{Hz}}$

(1) Shaded cells indicate same specification as the DAC712PK, UK grade.

(2) Digital inputs are TTL- and +5V CMOS-compatible over the specified temperature range.

(3) Errors externally adjustable to zero.

 (4) FSR means Full-Scale Range. For example, for a $\pm 10\text{V}$ output, FSR = 20V.

 (5) Maximum represents the 3σ limit. Not 100% tested for this parameter.

(6) For the worst-case code changes: FFFFh to 0000h and 0000h to FFFFh. These are binary twos complement (BTC) codes.

ELECTRICAL CHARACTERISTICS: DAC712PK, UK, PL, UL (continued)At $T_A = +25^\circ\text{C}$, $+V_{CC} = +12\text{V}$ and $+15\text{V}$, and $-V_{CC} = -12\text{V}$ and -15V , unless otherwise noted.

PARAMETER	TEST CONDITIONS	DAC712PK, UK			DAC712PL, UL ⁽¹⁾			UNIT
		MIN	TYP	MAX	MIN	TYP	MAX	
ANALOG OUTPUT								
Output Voltage Range								
+ V_{CC} , - $V_{CC} = \pm 11.4\text{V}$		± 10						V
Output Current		± 5						mA
Output Impedance			0.1					Ω
Short-Circuit to ACOM, Duration			Indefinite					
REFERENCE VOLTAGE								
Voltage		+9.975	+10.000	+10.025				V
T_{MIN} to T_{MAX}		+9.960		+10.040				V
Output Resistance			1					Ω
Source Current		2						mA
Short-Circuit to ACOM, Duration			Indefinite					
POWER-SUPPLY REQUIREMENTS								
Voltage								
+ V_{CC}		+11.4	+15	+16.5				V
- V_{CC}		-11.4	-15	-16.5				V
Current (No Load, $\pm 15\text{V}$ Supplies)								
+ V_{CC}			13	15				mA
- V_{CC}			22	25				mA
Power Dissipation ⁽⁷⁾			525	600				mW
TEMPERATURE RANGES								
Specified Temperature Range (All Grades)		0		+70				$^\circ\text{C}$
Storage Temperature Range		-60		+150				$^\circ\text{C}$
Thermal Coefficient, θ_{JA}								
DIP Package			75					$^\circ\text{C}/\text{W}$
SOIC Package			75					$^\circ\text{C}/\text{W}$

(7) Typical supply voltages times maximum currents.

PIN CONFIGURATION

**DW AND NT PACKAGES
SOIC-28 AND PDIP-28
(TOP VIEW)**

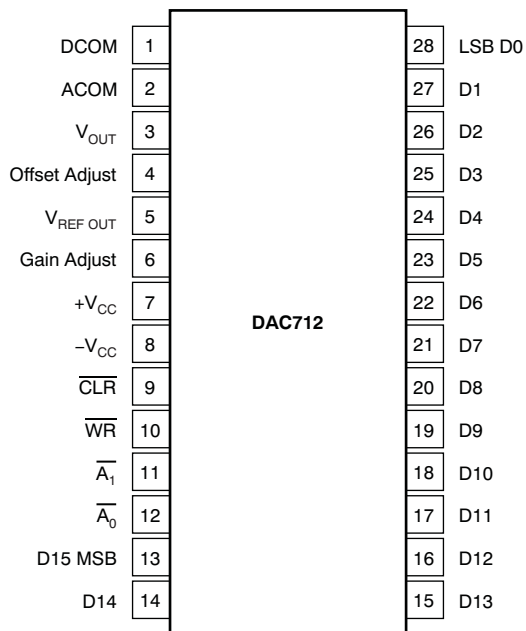

PIN DESCRIPTIONS

PIN	NAME	DESCRIPTION
1	DCOM	Power-Supply return for digital currents
2	ACOM	Analog Supply Return
3	V _{OUT}	±10V D/A Output
4	Offset Adjust	Offset Adjust (Bipolar)
5	V _{REF OUT}	Voltage Reference Output
6	Gain Adjust	Gain Adjust
7	+V _{CC}	+12V to +15V Supply
8	-V _{CC}	-12V to -15V Supply
9	$\overline{\text{CLR}}$	CLEAR; Sets D/A output to Bipolar Zero (Active Low)
10	$\overline{\text{WR}}$	Write (Active Low)
11	$\overline{\text{A}}_1$	Enable for D/A latch (Active Low)
12	$\overline{\text{A}}_0$	Enable for Input latch (Active Low)
13	D15	Data Bit 15 (Most Significant Bit)
14	D14	Data Bit 14
15	D13	Data Bit 13
16	D12	Data Bit 12
17	D11	Data Bit 11
18	D10	Data Bit 10
19	D9	Data Bit 9
20	D8	Data Bit 8
21	D7	Data Bit 7
22	D6	Data Bit 6
23	D5	Data Bit 5
24	D4	Data Bit 4
25	D3	Data Bit 3
26	D2	Data Bit 2
27	D1	Data Bit 1
28	D0	Data Bit 0 (Least Significant Bit)

TIMING CHARACTERISTICS

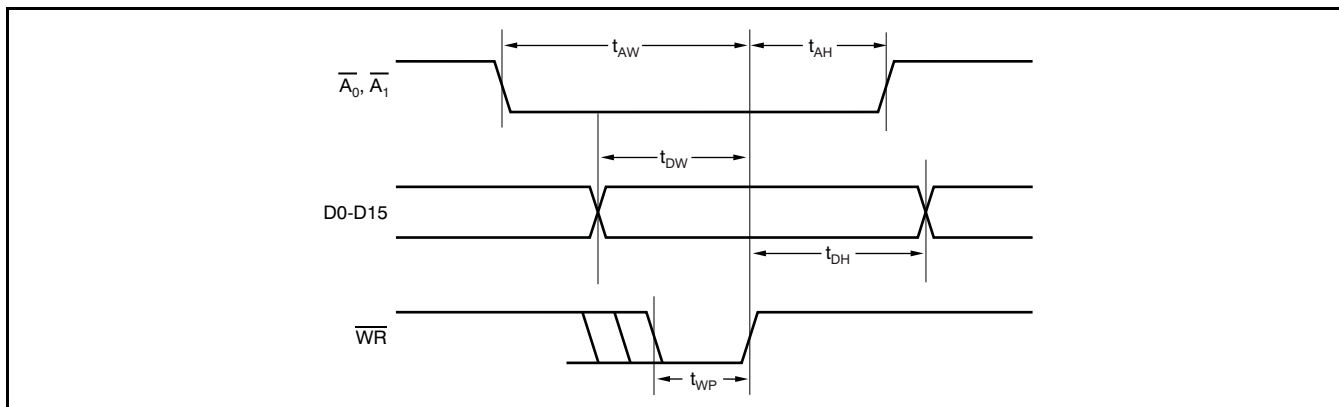

Figure 1. Timing Diagram

TIMING REQUIREMENTS

At $T_A = -40^\circ\text{C}$ to $+85^\circ\text{C}$, $+V_{CC} = +12\text{V}$ or $+15\text{V}$, and $-V_{CC} = -12\text{V}$ or -15V , unless otherwise noted.

PARAMETER	TEST CONDITIONS	DAC712			UNIT
		MIN	TYP	MAX	
t_{Dw}	Data Valid to End of \overline{WR}	50			ns
t_{AW}	$\overline{A_0}, \overline{A_1}$ Valid to End of \overline{WR}	50			ns
t_{AH}	$\overline{A_0}, \overline{A_1}$ Hold after End of \overline{WR}	10			ns
t_{DH}	Data Hold after End of \overline{WR}	10			ns
$t_{WP}^{(1)}$	Write Pulse Width	50			ns
t_{CP}	CLEAR Pulse Width	200			ns

(1) For single-buffered operation, t_{WP} is 80ns minimum; see the [Single-Buffered Operation](#) section.

TYPICAL CHARACTERISTICS

At $T_A = +25^\circ\text{C}$ and $V_{CC} = \pm 15\text{V}$, unless otherwise noted.

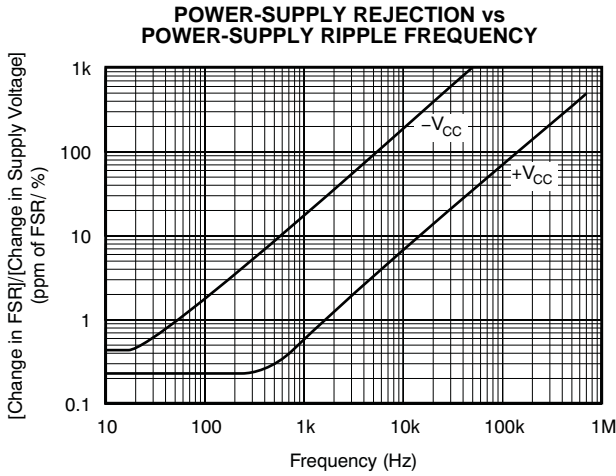

Figure 2.

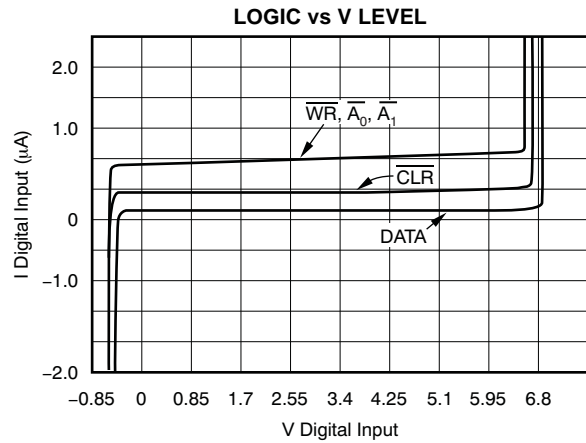

Figure 3.

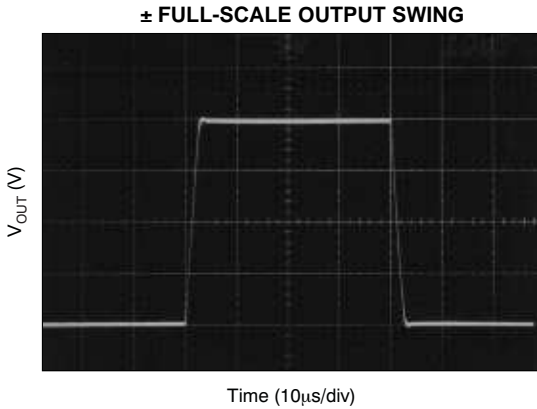

Figure 4.

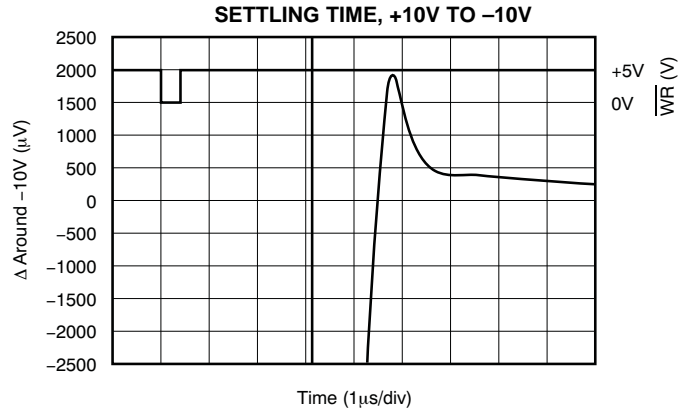

Figure 5.

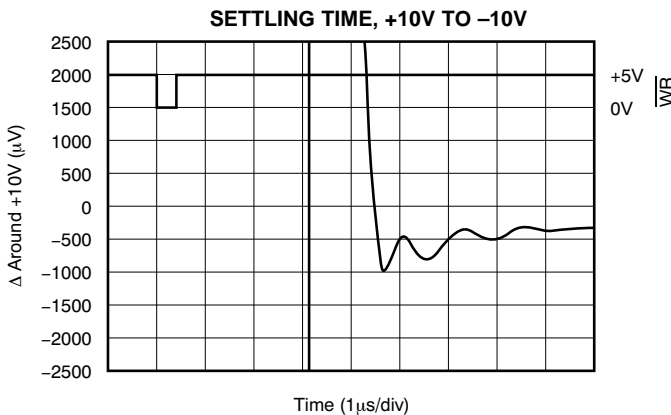

Figure 6.

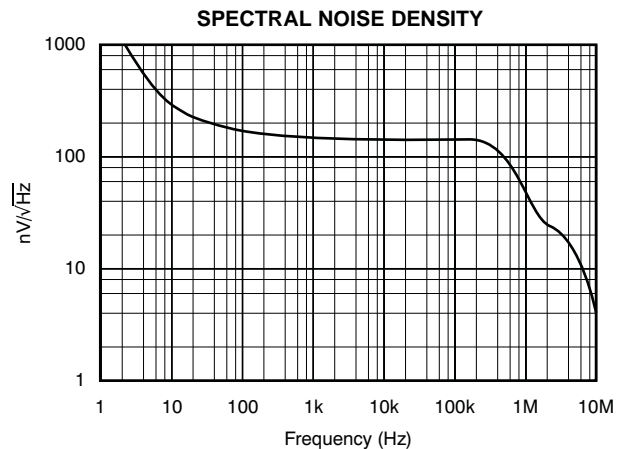

Figure 7.

DISCUSSION OF SPECIFICATIONS

LINEARITY ERROR

Linearity error is defined as the deviation of the analog output from a straight line drawn between the end points of the transfer characteristic.

DIFFERENTIAL LINEARITY ERROR

Differential linearity error (DLE) is the deviation from 1LSB of an output change from one adjacent state to the next. A DLE specification of $\pm 1/2$ LSB means that the output step size can range from 1/2LSB to 3/2LSB when the digital input code changes from one code word to the adjacent code word. If the DLE is more positive than -1 LSB, the D/A converter is said to be monotonic.

MONOTONICITY

A D/A converter is monotonic if the output either increases or remains the same for increasing digital input values. Monotonicity of the DAC712 is ensured over the specified temperature range to 13, 14, 15, and 16 bits for performance grades DAC712P/U, DAC712PB/UB, DAC712PK/UK, and DAC712PL/UL, respectively.

SETTLING TIME

Settling time is the total time (including slew time) for the D/A output to settle to within an error band around its final value after a change in input. Settling times are specified to within $\pm 0.003\%$ of Full-Scale Range (FSR) for an output step change of 20V and 1LSB. The 1LSB change is measured at the Major Carry (FFFFh to 0000h, and 0000h to FFFFh: BTC codes), the input transition at which worst-case settling time occurs.

TOTAL HARMONIC DISTORTION + NOISE

Total harmonic distortion + noise is defined as the ratio of the square root of the sum of the squares of the values of the harmonics and noise to the value of the fundamental frequency. It is expressed in % of the fundamental frequency amplitude at sampling rate f_s .

SIGNAL-TO-NOISE AND DISTORTION RATIO (SINAD)

SINAD includes all the harmonic and outstanding spurious components in the definition of output noise power in addition to quantizing and internal random noise power. SINAD is expressed in dB at a specified input frequency and sampling rate, f_s .

DIGITAL-TO-ANALOG GLITCH IMPULSE

The amount of charge injected into the analog output from the digital inputs when the inputs change state. It is measured at half-scale at the input codes where as many switches as possible change state—from 7FFFh to 8000h.

DIGITAL FEEDTHROUGH

When the analog-to-digital (A/D) converter is not selected, high-frequency logic activity on the digital inputs is coupled through the device and shows up as output noise. This noise is digital feedthrough.

OPERATION

The DAC712 is a monolithic integrated-circuit, 16-bit D/A converter complete with 16-bit D/A converter switches and ladder network, voltage reference, output amplifier, and microprocessor bus interface.

All latches are level-triggered. Data present when the enable inputs are logic '0' enter the latch. When the enable inputs return to logic '1', the data are latched.

The $\overline{\text{CLR}}$ input resets both the input latch and the D/A latch to give a bipolar zero output.

INTERFACE LOGIC

The DAC712 has double-buffered data latches. The input data latch holds a 16-bit data word before loading it into the second latch, the D/A latch. This double-buffered organization permits simultaneous update of several D/A converters. All digital control inputs are active low. Refer to the block diagram of Figure 8.

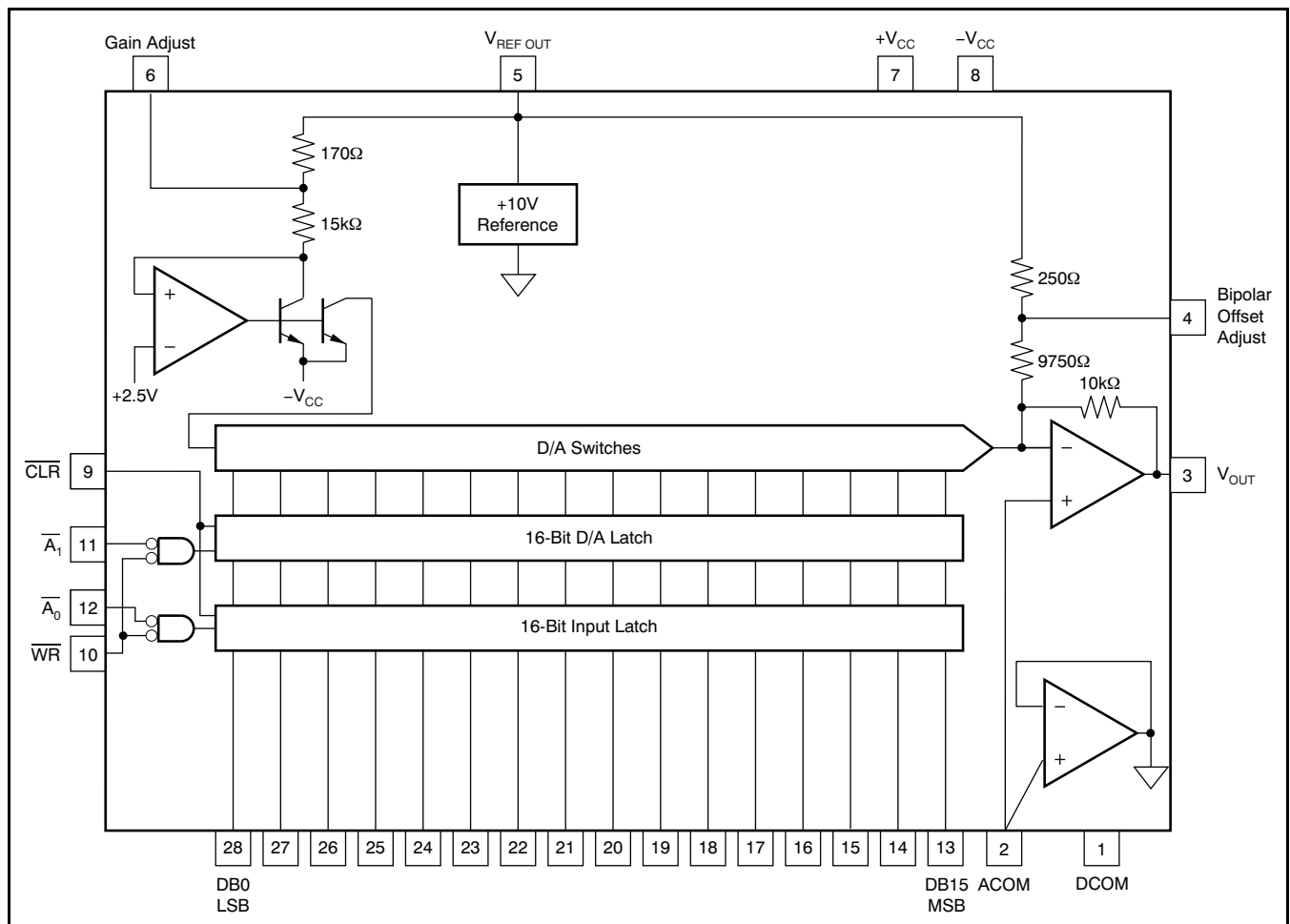

Figure 8. DAC712 Block Diagram

LOGIC INPUT COMPATIBILITY

The DAC712 digital inputs are TTL-compatible (1.4V switching level) with low-leakage, high-impedance inputs. Thus, the inputs are suitable for being driven by any type of 5V logic such as 5V CMOS logic. An equivalent circuit of a digital input is shown in Figure 9.

Data inputs float to logic '0' and control inputs float to logic '0' if left unconnected. It is recommended that any unused inputs be connected to DCOM to improve noise immunity.

Digital inputs remain high-impedance when power is off.



Figure 9. Equivalent Circuit of Digital Inputs

INPUT CODING

The DAC712 is designed to accept positive-true binary twos complement (BTC) input codes that are compatible with bipolar analog output operation. For bipolar analog output configuration, a digital input of 7FFFh gives a positive full-scale output, 8000h gives a negative full-scale output, and 0000h gives bipolar zero output.

INTERNAL REFERENCE

The DAC712 contains a +10V reference.

The reference output may be used to drive external loads, sourcing up to 2mA. The load current should be constant, otherwise the gain and bipolar offset of the converter will vary.

OUTPUT VOLTAGE SWING

The output amplifier of the DAC712 is committed to a ±10V output range. The DAC712 provides a ±10V output swing while operating on ±11.4V or higher voltage supplies.

GAIN AND OFFSET ADJUSTMENTS

Figure 10 illustrates the relationship of offset and gain adjustments for a bipolar connected D/A converter. Offset should be adjusted first to avoid interaction of adjustments. Table 1 shows calibration values and codes. These adjustments have a minimum range of ±0.3%.

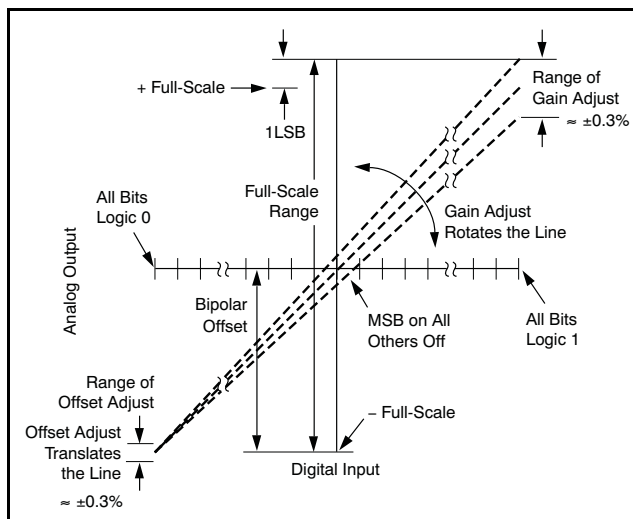

Figure 10. Relationship of Offset and Gain Adjustments

Table 1. Digital Input and Analog Output Voltage Calibration Values

DAC712 CALIBRATION VALUES 1 LEAST SIGNIFICANT BIT = 305µV		
DIGITAL INPUT CODE BINARY TWOS COMPLEMENT, BTC	ANALOG OUTPUT (V)	DESCRIPTION
7FFFh	+9.999695	Positive Full-Scale – 1LSB
4000h	+5.000000	3/4 Scale
0001h	+0.000305	BPZ + 1LSB
0000h	0.000000	Bipolar Zero (BPZ)
FFFFh	–0.000305	BPZ – 1LSB
C000h	–5.000000	1/4 Scale
8000h	–10.000000	Negative Full-Scale

Offset Adjustment

Apply the digital input code that produces the maximum negative output voltage and adjust the offset potentiometer or the offset adjust D/A converter for –10V.

Gain Adjustment

Apply the digital input that gives the maximum positive voltage output. Adjust the gain potentiometer or the gain adjust D/A converter for this positive full-scale voltage.

INSTALLATION

GENERAL CONSIDERATIONS

Because of the high accuracy of these D/A converters, system design problems such as grounding and contact resistance become very important. A 16-bit converter with a 20V full-scale range has a 1LSB value of 305mV. With a load current of 5 μ A, series wiring and connector resistance of only 60m Ω causes a voltage drop of 300 μ V. To understand what this means in terms of a system layout, the resistivity of a typical 1-ounce copper-clad printed circuit board (PCB) is 1/2m Ω per square. For a 5mA load, a 10 mil (0.010 inch) wide printed circuit conductor 60 milli-inches long results in a voltage drop of 150 μ V.

The analog output of the DAC712 has an LSB size of 305 μ V (–96dB). The noise floor of the D/A converter must remain below this level in the frequency range of interest. The DAC712 noise spectral density (which includes the noise contributed by the internal reference) is shown in the [Typical Characteristics](#) section.

Wiring to high-resolution D/A converters should be routed to provide optimum isolation from sources of radio frequency interference (RFI) and electromagnetic interference (EMI). The key to elimination of RF radiation or pickup is a small loop area. Signal leads and the return conductors should be kept close together such that they present a small capture cross-section for any external field. Wire-wrap construction is not recommended.

POWER-SUPPLY AND REFERENCE CONNECTIONS

Power-supply decoupling capacitors should be added as shown in [Figure 11](#). Best performance occurs using a 1 μ F to 10 μ F tantalum capacitor at $-V_{CC}$. Applications with less critical settling time may be able to use 0.01 μ F at $-V_{CC}$ as well as at $+V_{CC}$. The capacitors should be located close to the package.

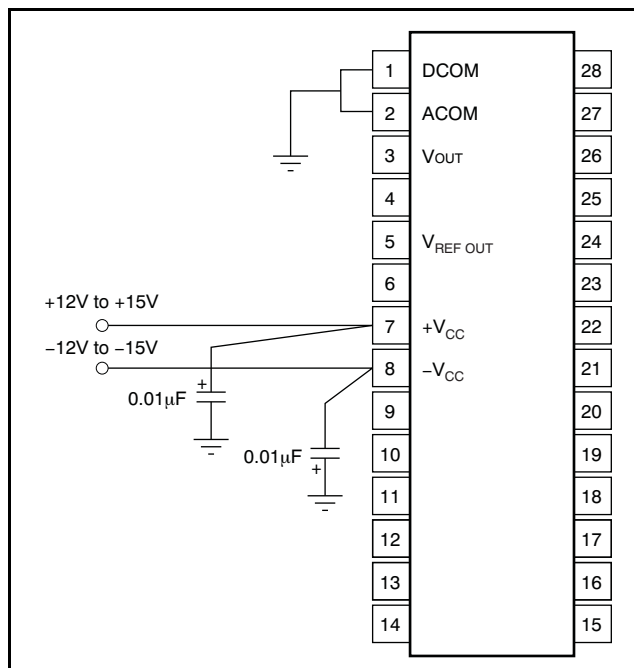

Figure 11. Power-Supply Connections

The DAC712 has separate ANALOG COMMON and DIGITAL COMMON pins. The current through DCOM is mostly switching transients and are up to 1mA peak in amplitude. The current through ACOM is typically 5 μ A for all codes.

Use separate analog and digital ground planes with a single interconnection point to minimize ground loops. The analog pins are located adjacent to each other to help isolate analog from digital signals. Analog signals should be routed as far as possible from digital signals and should cross them at right angles. A solid analog ground plane around the D/A converter package, as well as under it in the vicinity of the analog and power-supply pins, isolates the D/A converter from switching currents. It is recommended that DCOM and ACOM be connected directly to the ground planes under the package.

If several DAC712s are used, or if the DAC712 shares supplies with other components, connecting the ACOM and DCOM lines together once at the power supplies rather than at each chip may give better results.

LOAD CONNECTIONS

Because the reference point for V_{OUT} and $V_{REF OUT}$ is the ACOM pin, it is important to connect the D/A converter load directly to the ACOM pin; see Figure 12.

Lead and contact resistances are represented by R_1 through R_3 . As long as the load resistance R_L is constant, R_1 simply introduces a gain error and can be removed by gain adjustment of the D/A converter or system-wide gain calibration. R_2 is part of R_L if the output voltage is sensed at ACOM.

In some applications it is impractical to return the load to the ACOM pin of the D/A converter. Sensing the output voltage at the SYSTEM GROUND point is reasonable, because there is no change in the DAC712 ACOM current, provided that R_3 is a low-resistance ground plane or conductor. In this case, DCOM may be connected to SYSTEM GROUND as well.

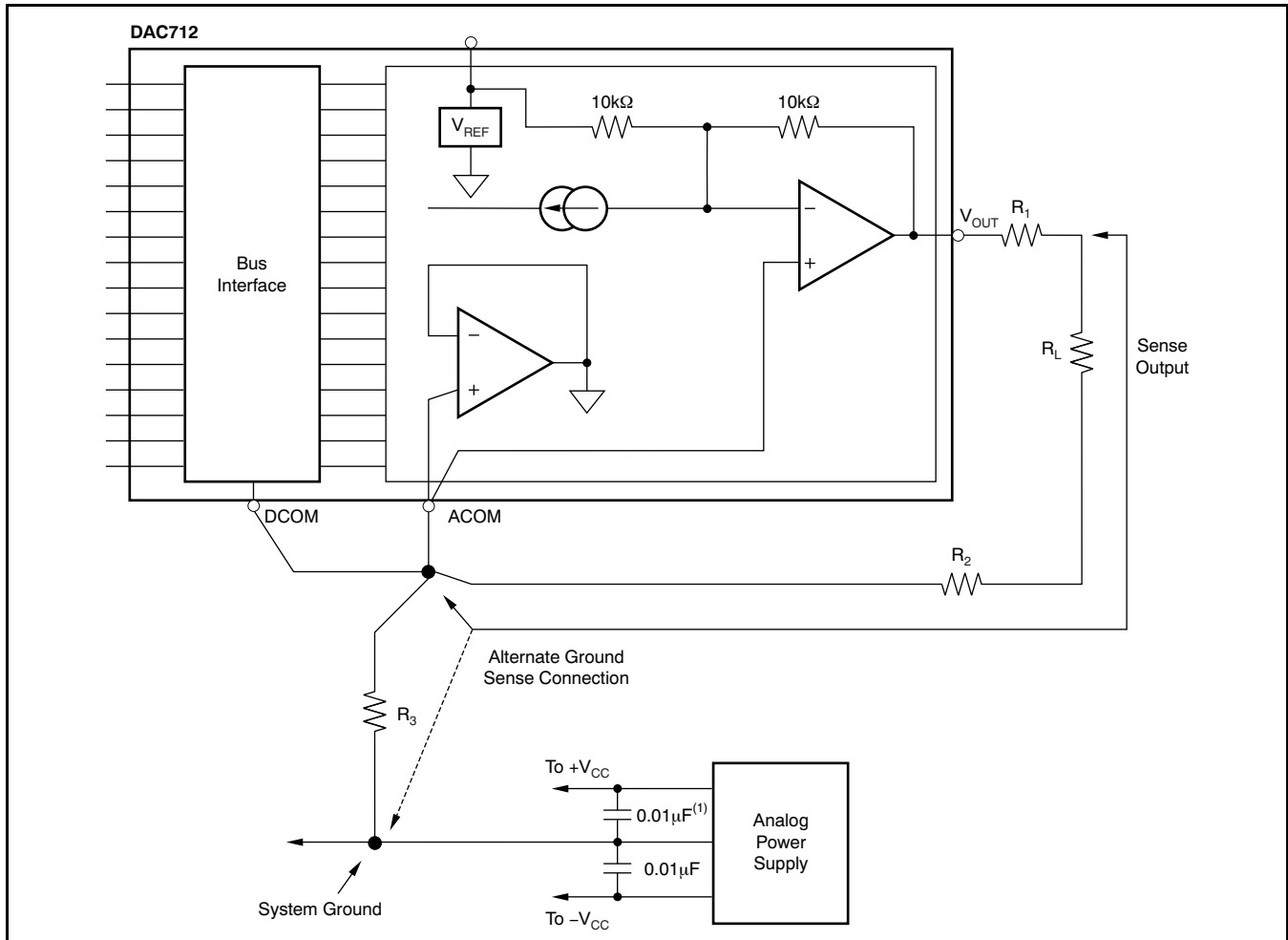

(1) Locate close to the DAC712 package.

Figure 12. System Ground Considerations for High-Resolution D/A Converters

GAIN AND OFFSET ADJUST

Connections Using Potentiometers

GAIN and OFFSET adjust pins provide for trim using external potentiometers. 15-turn potentiometers provide sufficient resolution. Range of adjustment of these trims is at least $\pm 0.3\%$ of Full-Scale Range; see Figure 13.

Using D/A Converters

The GAIN ADJUST and OFFSET ADJUST circuits of the DAC712 have been arranged so that these points may be easily driven by external D/A converters; see Figure 14. 12-bit D/A converters provide an OFFSET adjust resolution and a GAIN adjust resolution of $30\mu\text{V}$ to $50\mu\text{V}$ per LSB step.

Nominal values of GAIN and OFFSET occur when the D/A converter outputs are at approximately half scale, +5V.

OUTPUT VOLTAGE RANGE CONNECTIONS

The DAC712 output amplifier is connected internally for the $\pm 10\text{V}$ bipolar (20V) output range. That is, the bipolar offset resistor is connected to an internal reference voltage and the 20V range resistor is connected internally to V_{OUT} . The DAC712 cannot be connected for unipolar operation.

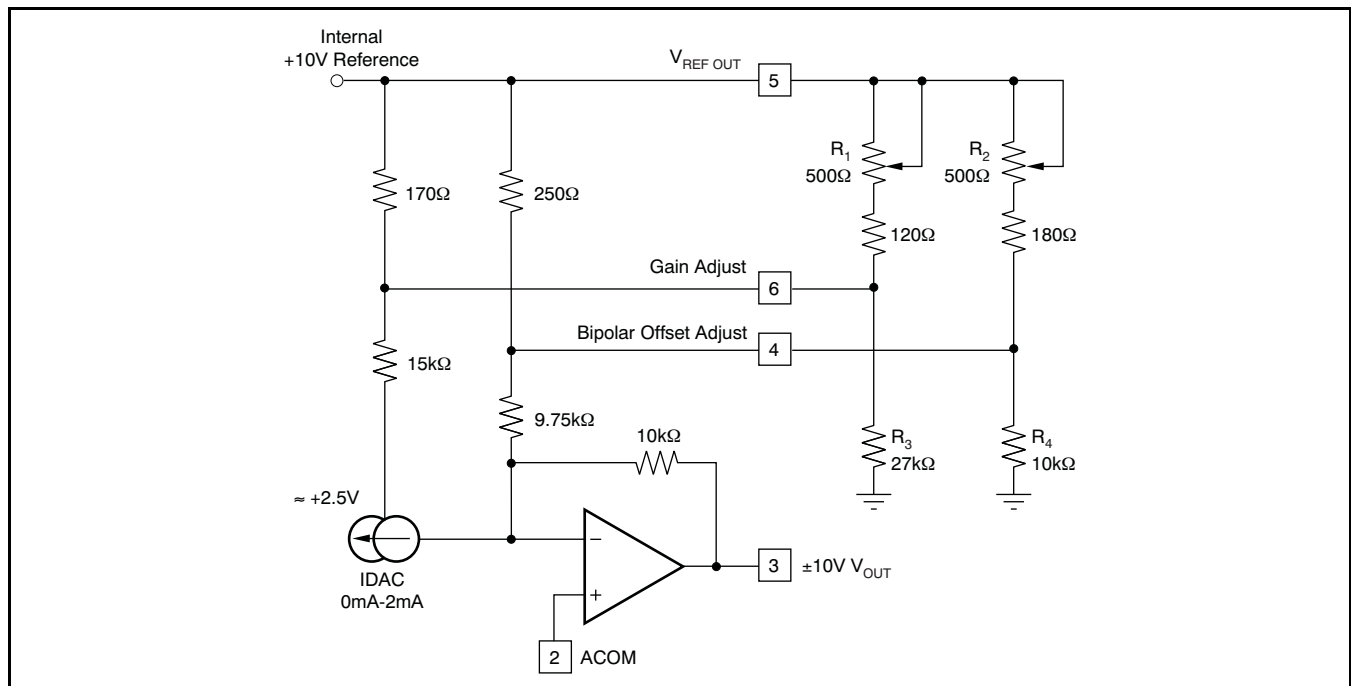

(1) For no external adjustments, pins 4 and 6 are not connected. External Resistors R_1 to R_4 are standard $\pm 1\%$ values. Range of adjustment is at least $\pm 0.3\%$ FSR.

Figure 13. Manual Offset and Gain Adjust Circuits

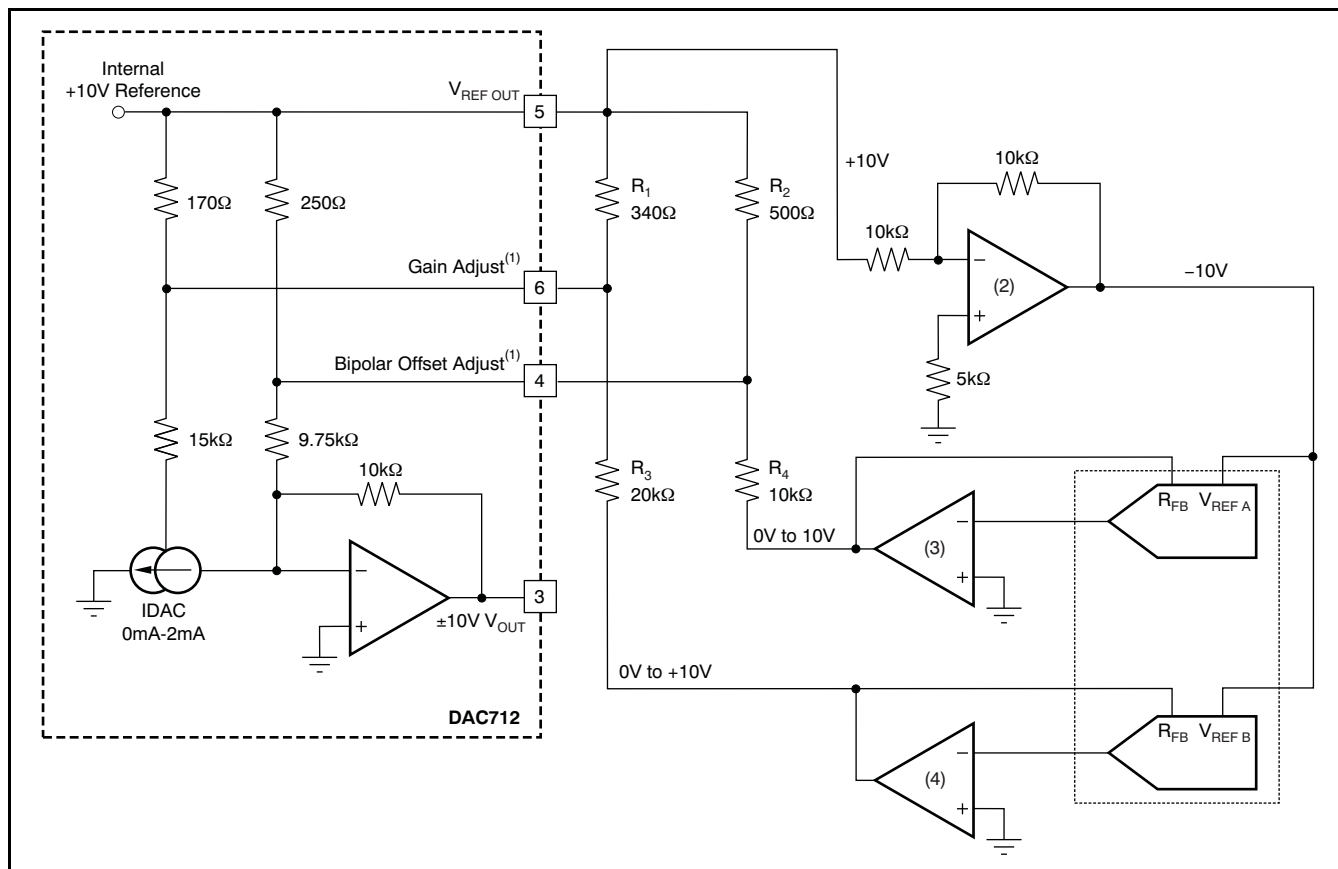

(1) For no external adjustments, pins 4 and 6 are not connected. External Resistors R₁ to R₄ tolerance is ±1% values. Range of adjustment is at least ±0.3% FSR.

(2) Suggested op amps: OPA177GP, GS or OPA604AP, AU.

(3) Suggested op amps: single OPA177GP, GS or dual OPA2604AP, AU.

(4) Suggested D/A converters: dual DAC7800 (serial input, 12-bit resolution); dual DAC7801 (8-bit port input, 12-bit resolution); dual DAC7802 (12-bit port input, 12-bit resolution); dual DAC7545 (12-bit port input, 12-bit resolution); or single DAC8043 (serial input, 12-bit resolution). BIPOLAR (complete): DAC813 (use 11-bit resolution for 0V to +10V output; no op-amps required).

Figure 14. Gain and Offset Adjustment Using D/A Converters

DIGITAL INTERFACE

BUS INTERFACE

The DAC712 has 16-bit, double-buffered data bus interface with control lines for easy interface to a 16-bit bus. The double-buffered feature permits update of several D/A converters simultaneously.

$\overline{A_0}$ is the enable control for the DATA INPUT LATCH. $\overline{A_1}$ is the enable for the D/A LATCH. \overline{WR} is used to strobe data into latches enabled by $\overline{A_0}$ and $\overline{A_1}$. Refer to the block diagram of Figure 8 and to Figure 1.

\overline{CLR} sets the INPUT DATA LATCH to all zeros and the D/A LATCH to a code that gives bipolar 0V at the D/A converter output.

SINGLE-BUFFERED OPERATION

To operate the DAC712 interface as a single-buffered latch, the DATA INPUT LATCH is permanently enabled by connecting $\overline{A_0}$ to DCOM. If $\overline{A_1}$ is not used to enable the D/A converter, it should be connected to DCOM as well. For this mode of operation, the width of \overline{WR} must be at least 80ns minimum to pass data through the DATA INPUT LATCH and into the D/A LATCH.

TRANSPARENT INTERFACE

The digital interface of the DAC712 can be made transparent by asserting $\overline{A_0}$, $\overline{A_1}$, and \overline{WR} LOW, and asserting CLR HIGH.

Revision History

NOTE: Page numbers for previous revisions may differ from page numbers in the current version.

Changes from Original (September 200) to Revision A	Page
• Updated document format to current standards	1
• Changed max specification for Accuracy, Gain Error, T_{MIN} to T_{MAX} parameter in <i>Electrical Characteristics</i> : DAC712PK, UK, PL, UL table.....	5

PACKAGING INFORMATION

Orderable Device	Status (1)	Package Type	Package Drawing	Pins	Package Qty	Eco Plan (2)	Lead/Ball Finish (6)	MSL Peak Temp (3)	Op Temp (°C)	Device Marking (4/5)	Samples
DAC712U	ACTIVE	SOIC	DW	28	20	Green (RoHS & no Sb/Br)	CU NIPDAU	Level-3-260C-168 HR	-40 to 85	DAC712U	Samples
DAC712UB	ACTIVE	SOIC	DW	28	20	Green (RoHS & no Sb/Br)	CU NIPDAU	Level-3-260C-168 HR	-40 to 85	DAC712U B	Samples
DAC712UBG4	ACTIVE	SOIC	DW	28	20	Green (RoHS & no Sb/Br)	CU NIPDAU	Level-3-260C-168 HR	-40 to 85	DAC712U B	Samples
DAC712UG4	ACTIVE	SOIC	DW	28	20	Green (RoHS & no Sb/Br)	CU NIPDAU	Level-3-260C-168 HR	-40 to 85	DAC712U	Samples
DAC712UK	ACTIVE	SOIC	DW	28	20	Green (RoHS & no Sb/Br)	CU NIPDAU	Level-3-260C-168 HR	0 to 70	DAC712U K	Samples
DAC712UKG4	ACTIVE	SOIC	DW	28	20	Green (RoHS & no Sb/Br)	CU NIPDAU	Level-3-260C-168 HR	0 to 70	DAC712U K	Samples
DAC712UL	ACTIVE	SOIC	DW	28	20	Green (RoHS & no Sb/Br)	CU NIPDAU	Level-3-260C-168 HR	0 to 70	DAC712U L	Samples
DAC712ULG4	ACTIVE	SOIC	DW	28	20	Green (RoHS & no Sb/Br)	CU NIPDAU	Level-3-260C-168 HR	0 to 70	DAC712U L	Samples

(1) The marketing status values are defined as follows:

ACTIVE: Product device recommended for new designs.

LIFEBUY: TI has announced that the device will be discontinued, and a lifetime-buy period is in effect.

NRND: Not recommended for new designs. Device is in production to support existing customers, but TI does not recommend using this part in a new design.

PREVIEW: Device has been announced but is not in production. Samples may or may not be available.

OBSOLETE: TI has discontinued the production of the device.

(2) Eco Plan - The planned eco-friendly classification: Pb-Free (RoHS), Pb-Free (RoHS Exempt), or Green (RoHS & no Sb/Br) - please check <http://www.ti.com/productcontent> for the latest availability information and additional product content details.

TBD: The Pb-Free/Green conversion plan has not been defined.

Pb-Free (RoHS): TI's terms "Lead-Free" or "Pb-Free" mean semiconductor products that are compatible with the current RoHS requirements for all 6 substances, including the requirement that lead not exceed 0.1% by weight in homogeneous materials. Where designed to be soldered at high temperatures, TI Pb-Free products are suitable for use in specified lead-free processes.

Pb-Free (RoHS Exempt): This component has a RoHS exemption for either 1) lead-based flip-chip solder bumps used between the die and package, or 2) lead-based die adhesive used between the die and leadframe. The component is otherwise considered Pb-Free (RoHS compatible) as defined above.

Green (RoHS & no Sb/Br): TI defines "Green" to mean Pb-Free (RoHS compatible), and free of Bromine (Br) and Antimony (Sb) based flame retardants (Br or Sb do not exceed 0.1% by weight in homogeneous material)

(3) MSL, Peak Temp. - The Moisture Sensitivity Level rating according to the JEDEC industry standard classifications, and peak solder temperature.

(4) There may be additional marking, which relates to the logo, the lot trace code information, or the environmental category on the device.

(5) Multiple Device Markings will be inside parentheses. Only one Device Marking contained in parentheses and separated by a "~" will appear on a device. If a line is indented then it is a continuation of the previous line and the two combined represent the entire Device Marking for that device.

(6) Lead/Ball Finish - Orderable Devices may have multiple material finish options. Finish options are separated by a vertical ruled line. Lead/Ball Finish values may wrap to two lines if the finish value exceeds the maximum column width.

Important Information and Disclaimer:The information provided on this page represents TI's knowledge and belief as of the date that it is provided. TI bases its knowledge and belief on information provided by third parties, and makes no representation or warranty as to the accuracy of such information. Efforts are underway to better integrate information from third parties. TI has taken and continues to take reasonable steps to provide representative and accurate information but may not have conducted destructive testing or chemical analysis on incoming materials and chemicals. TI and TI suppliers consider certain information to be proprietary, and thus CAS numbers and other limited information may not be available for release.

In no event shall TI's liability arising out of such information exceed the total purchase price of the TI part(s) at issue in this document sold by TI to Customer on an annual basis.

DW (R-PDSO-G28)

PLASTIC SMALL OUTLINE

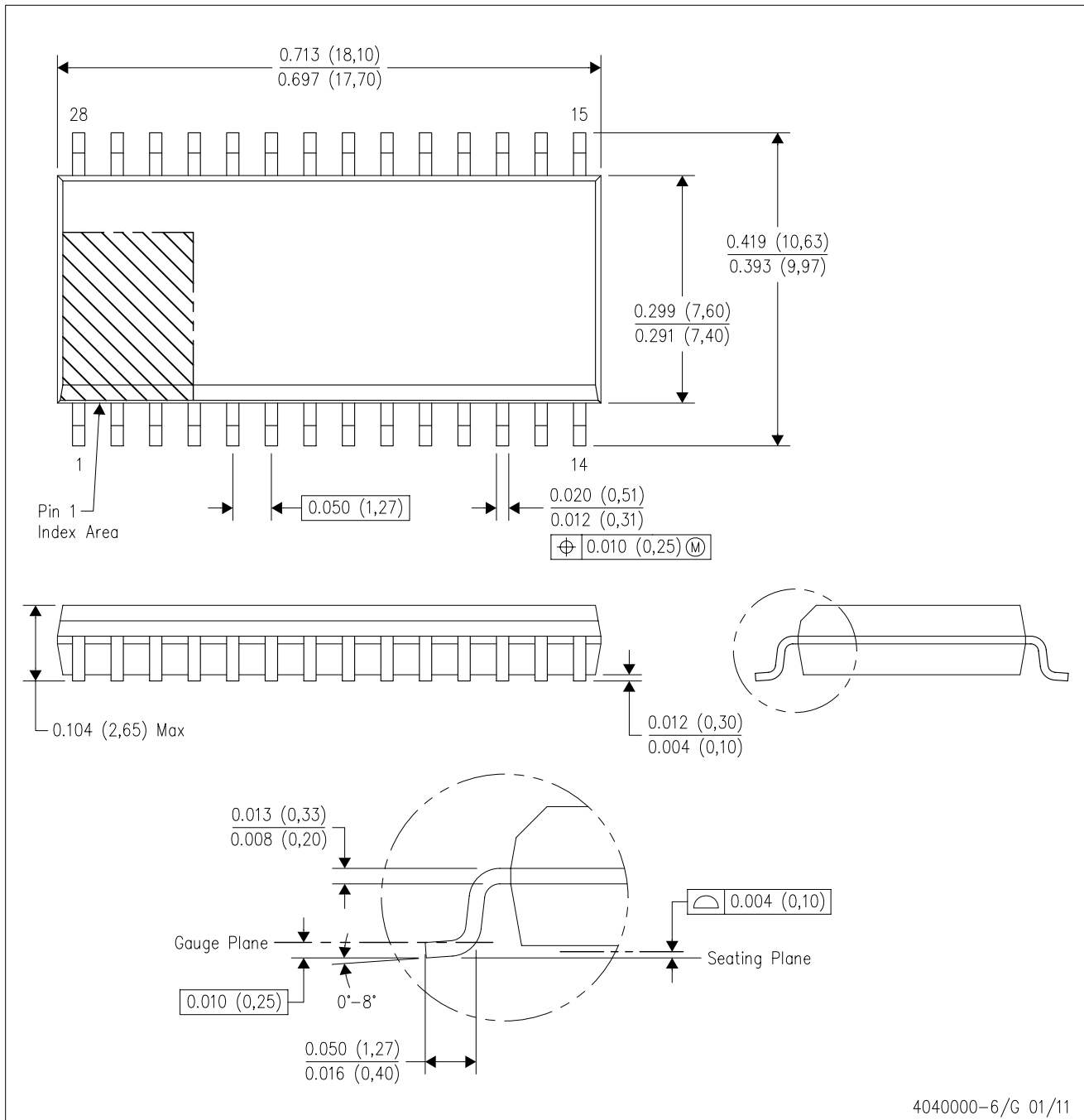

4040000-6/G 01/11

- NOTES:
- All linear dimensions are in inches (millimeters). Dimensioning and tolerancing per ASME Y14.5M-1994.
 - This drawing is subject to change without notice.
 - Body dimensions do not include mold flash or protrusion not to exceed 0.006 (0,15).
 - Falls within JEDEC MS-013 variation AE.

DW (R-PDSO-G28)

PLASTIC SMALL OUTLINE

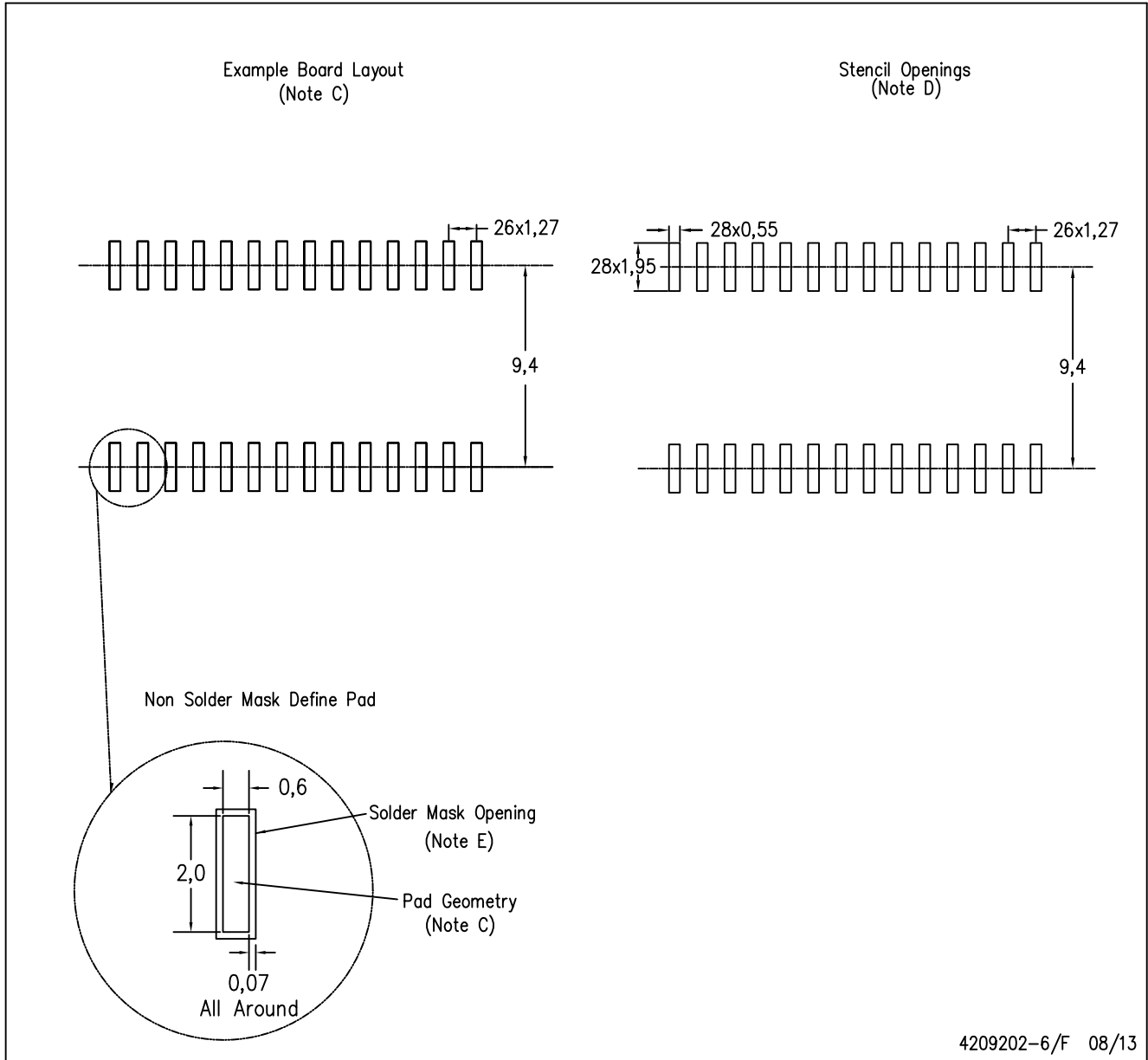

4209202-6/F 08/13

- NOTES:
- A. All linear dimensions are in millimeters.
 - B. This drawing is subject to change without notice.
 - C. Refer to IPC7351 for alternate board design.
 - D. Laser cutting apertures with trapezoidal walls and also rounding corners will offer better paste release. Customers should contact their board assembly site for stencil design recommendations. Refer to IPC-7525
 - E. Customers should contact their board fabrication site for solder mask tolerances between and around signal pads.

IMPORTANT NOTICE

Texas Instruments Incorporated (TI) reserves the right to make corrections, enhancements, improvements and other changes to its semiconductor products and services per JESD46, latest issue, and to discontinue any product or service per JESD48, latest issue. Buyers should obtain the latest relevant information before placing orders and should verify that such information is current and complete.

TI's published terms of sale for semiconductor products (<http://www.ti.com/sc/docs/stdterms.htm>) apply to the sale of packaged integrated circuit products that TI has qualified and released to market. Additional terms may apply to the use or sale of other types of TI products and services.

Reproduction of significant portions of TI information in TI data sheets is permissible only if reproduction is without alteration and is accompanied by all associated warranties, conditions, limitations, and notices. TI is not responsible or liable for such reproduced documentation. Information of third parties may be subject to additional restrictions. Resale of TI products or services with statements different from or beyond the parameters stated by TI for that product or service voids all express and any implied warranties for the associated TI product or service and is an unfair and deceptive business practice. TI is not responsible or liable for any such statements.

Buyers and others who are developing systems that incorporate TI products (collectively, "Designers") understand and agree that Designers remain responsible for using their independent analysis, evaluation and judgment in designing their applications and that Designers have full and exclusive responsibility to assure the safety of Designers' applications and compliance of their applications (and of all TI products used in or for Designers' applications) with all applicable regulations, laws and other applicable requirements. Designer represents that, with respect to their applications, Designer has all the necessary expertise to create and implement safeguards that (1) anticipate dangerous consequences of failures, (2) monitor failures and their consequences, and (3) lessen the likelihood of failures that might cause harm and take appropriate actions. Designer agrees that prior to using or distributing any applications that include TI products, Designer will thoroughly test such applications and the functionality of such TI products as used in such applications.

TI's provision of technical, application or other design advice, quality characterization, reliability data or other services or information, including, but not limited to, reference designs and materials relating to evaluation modules, (collectively, "TI Resources") are intended to assist designers who are developing applications that incorporate TI products; by downloading, accessing or using TI Resources in any way, Designer (individually or, if Designer is acting on behalf of a company, Designer's company) agrees to use any particular TI Resource solely for this purpose and subject to the terms of this Notice.

TI's provision of TI Resources does not expand or otherwise alter TI's applicable published warranties or warranty disclaimers for TI products, and no additional obligations or liabilities arise from TI providing such TI Resources. TI reserves the right to make corrections, enhancements, improvements and other changes to its TI Resources. TI has not conducted any testing other than that specifically described in the published documentation for a particular TI Resource.

Designer is authorized to use, copy and modify any individual TI Resource only in connection with the development of applications that include the TI product(s) identified in such TI Resource. NO OTHER LICENSE, EXPRESS OR IMPLIED, BY ESTOPPEL OR OTHERWISE TO ANY OTHER TI INTELLECTUAL PROPERTY RIGHT, AND NO LICENSE TO ANY TECHNOLOGY OR INTELLECTUAL PROPERTY RIGHT OF TI OR ANY THIRD PARTY IS GRANTED HEREIN, including but not limited to any patent right, copyright, mask work right, or other intellectual property right relating to any combination, machine, or process in which TI products or services are used. Information regarding or referencing third-party products or services does not constitute a license to use such products or services, or a warranty or endorsement thereof. Use of TI Resources may require a license from a third party under the patents or other intellectual property of the third party, or a license from TI under the patents or other intellectual property of TI.

TI RESOURCES ARE PROVIDED "AS IS" AND WITH ALL FAULTS. TI DISCLAIMS ALL OTHER WARRANTIES OR REPRESENTATIONS, EXPRESS OR IMPLIED, REGARDING RESOURCES OR USE THEREOF, INCLUDING BUT NOT LIMITED TO ACCURACY OR COMPLETENESS, TITLE, ANY EPIDEMIC FAILURE WARRANTY AND ANY IMPLIED WARRANTIES OF MERCHANTABILITY, FITNESS FOR A PARTICULAR PURPOSE, AND NON-INFRINGEMENT OF ANY THIRD PARTY INTELLECTUAL PROPERTY RIGHTS. TI SHALL NOT BE LIABLE FOR AND SHALL NOT DEFEND OR INDEMNIFY DESIGNER AGAINST ANY CLAIM, INCLUDING BUT NOT LIMITED TO ANY INFRINGEMENT CLAIM THAT RELATES TO OR IS BASED ON ANY COMBINATION OF PRODUCTS EVEN IF DESCRIBED IN TI RESOURCES OR OTHERWISE. IN NO EVENT SHALL TI BE LIABLE FOR ANY ACTUAL, DIRECT, SPECIAL, COLLATERAL, INDIRECT, PUNITIVE, INCIDENTAL, CONSEQUENTIAL OR EXEMPLARY DAMAGES IN CONNECTION WITH OR ARISING OUT OF TI RESOURCES OR USE THEREOF, AND REGARDLESS OF WHETHER TI HAS BEEN ADVISED OF THE POSSIBILITY OF SUCH DAMAGES.

Unless TI has explicitly designated an individual product as meeting the requirements of a particular industry standard (e.g., ISO/TS 16949 and ISO 26262), TI is not responsible for any failure to meet such industry standard requirements.

Where TI specifically promotes products as facilitating functional safety or as compliant with industry functional safety standards, such products are intended to help enable customers to design and create their own applications that meet applicable functional safety standards and requirements. Using products in an application does not by itself establish any safety features in the application. Designers must ensure compliance with safety-related requirements and standards applicable to their applications. Designer may not use any TI products in life-critical medical equipment unless authorized officers of the parties have executed a special contract specifically governing such use. Life-critical medical equipment is medical equipment where failure of such equipment would cause serious bodily injury or death (e.g., life support, pacemakers, defibrillators, heart pumps, neurostimulators, and implantables). Such equipment includes, without limitation, all medical devices identified by the U.S. Food and Drug Administration as Class III devices and equivalent classifications outside the U.S.

TI may expressly designate certain products as completing a particular qualification (e.g., Q100, Military Grade, or Enhanced Product). Designers agree that it has the necessary expertise to select the product with the appropriate qualification designation for their applications and that proper product selection is at Designers' own risk. Designers are solely responsible for compliance with all legal and regulatory requirements in connection with such selection.

Designer will fully indemnify TI and its representatives against any damages, costs, losses, and/or liabilities arising out of Designer's non-compliance with the terms and provisions of this Notice.

Looking for pricing, stock, or lifecycle information?

Click below to explore more details on WIN SOURCE:

 [View DAC712UKG4 on WIN SOURCE](#)

 [Texas Instruments](#) Information

Optimize Your Supply Chain with WIN SOURCE Solutions

-  Global Sourcing Solution
-  Obsolete Management
-  Cost Control Management
-  Shortage Management
-  Alternative Solution
-  Excess Inventory Management