

## Power Capacitors

**Series/Type: B25835**

The following products presented in this data sheet are being withdrawn.

Ordering Code	Substitute Product	Date of Withdrawal	Deadline Last Orders	Last Shipments
B25835M7474K007		2014-08-14	2015-03-31	2016-09-30
B25835M7224K007		2014-08-14	2015-03-31	2016-09-30
B25835M7104K007		2014-08-14	2015-03-31	2016-09-30

© EPCOS AG 2015. Reproduction, publication and dissemination of this publication, enclosures hereto and the information contained therein without EPCOS' prior express consent is prohibited.

EPCOS AG is a TDK Group Company.



Ordering Code	Substitute Product	Date of Withdrawal	Deadline Last Orders	Last Shipments
B25835M6684K007		2014-08-14	2015-03-31	2016-09-30
B25835M6475K007		2014-08-14	2015-03-31	2016-09-30
B25835M6474K007		2014-08-14	2015-03-31	2016-09-30
B25835M6334K007		2014-08-14	2015-03-31	2016-09-30
B25835M6225K007		2014-08-14	2015-03-31	2016-09-30
B25835M6224K007		2014-08-14	2015-03-31	2016-09-30
B25835M6105K007		2014-08-14	2015-03-31	2016-09-30
B25835M2684K007		2014-08-14	2015-03-31	2016-09-30
B25835M2474K007		2014-08-14	2015-03-31	2016-09-30
B25835M2334K007		2014-08-14	2015-03-31	2016-09-30
B25835M2224K007		2014-08-14	2015-03-31	2016-09-30
B25835M2154K007		2014-08-14	2015-03-31	2016-09-30
B25835M2104K007		2014-08-14	2015-03-31	2016-09-30
B25835M1684K007		2014-08-14	2015-03-31	2016-09-30
B25835M1474K007		2014-08-14	2015-03-31	2016-09-30
B25835M1225K007		2014-08-14	2015-03-31	2016-09-30
B25835M1105K007		2014-08-14	2015-03-31	2016-09-30
B25835M0684K007		2014-08-14	2015-03-31	2016-09-30
B25835M0474K007		2014-08-14	2015-03-31	2016-09-30
B25835M0334K007		2014-08-14	2015-03-31	2016-09-30
B25835M0225K007		2014-08-14	2015-03-31	2016-09-30
B25835M0224K007		2014-08-14	2015-03-31	2016-09-30
B25835M0105K007		2014-08-14	2015-03-31	2016-09-30
B25835M0104K007		2014-08-14	2015-03-31	2016-09-30

For further information please contact your nearest EPCOS sales office, which will also support you in selecting a suitable substitute. The addresses of our worldwide sales network are presented at [www.epcos.com/sales](http://www.epcos.com/sales).

**Damping**
**Features**

- High dielectric strength
- High peak-current capability

**Applications**

- Especially suitable for snubber circuits

**Construction**

- Self-healing
- Plastic dielectric
- Oil-impregnated tubular windings (no PCB)
- Metal-sprayed end faces ensure reliable contacting
- Cylindrical aluminum case
- 1-pole version, ceramic lead-through
- Mounting bolts M8 or M12

**Terminals**

- Tab connector 6.3 mm

**Mounting**

- If the vibration stress is  $\leq 5$  g the bolt is used for mounting.

**Grounding**

- 1-pole capacitors need not be grounded.

**Overpressure disconnecter (mechanical)**

When the overpressure responds, the capacitor extends by up 8 mm.  
So leave sufficient space above the terminals when mounting the capacitor.

**Individual data sheets**

Individual data sheets contain detailed specification incl. thermal data.  
Upon request, these data sheets are available for each capacitor type.



**Damping**
**Technical data**

Standards		IEC 1071-1/2 EN 61071-1/2 VDE 0560 part 120 and 121
Dielectric dissipation factor	$\tan \delta_0$	$2 \cdot 10^{-4}$
Capacitance tolerance		$\pm 10\%$
Max. repetitive rate of voltage rise	$(dv/dt)_{\max}$	$\frac{\hat{I}}{C}$
Max. non-repetitive rate of voltage rise	$(dv/dt)_s$	$\frac{I_s}{C}$
Climatic data:		
Min. operating temperature	$T_{\min}$	$-25\text{ }^\circ\text{C}$
Max. operating temperature	$T_{\max}$	$+85\text{ }^\circ\text{C}$
Average relative humidity		$\leq 95\%$
Failure quota	$\alpha_{FQ(\text{co})}$	300 failures per $10^9$ component hours
Load duration	$t_{LD(\text{co})}$	100 000 h
Storage temperature limit	$T_{\text{stg}}$	$-55/+85\text{ }^\circ\text{C}$
IEC climatic category (IEC 68-1 and 2)		25/085/56
Test data:		
AC test voltage between terminals	$V_{TT}$	$1.25 \times V_R$ , 50 Hz, 10 s (or DC $1.75 \times V_R$ , 10 s)
Insulation resistance	$R_{\text{ins}}$	$C_R \leq 1\text{ }\mu\text{F}$ : $\geq 10\,000\text{ M}\Omega$
Self-discharge time constant	$\tau = R_{\text{ins}} \times C$	$C_R > 1\text{ }\mu\text{F}$ : $\geq 10\,000\text{ s}$
Dissipation factor (50 Hz)	$\tan \delta$	$\leq 3 \cdot 10^{-4}$

**Damping**
**Characteristics and ordering codes**

$C_R^{1)}$	$I_{\max}$	$\hat{i}$	$I_s$	$R_S$ 20 °C	$L_{\text{self}}$	Dimensions $d \times l$	Fig.	Appr. weight	Ordering code
$\mu\text{F}$	A	A	A	$\text{m}\Omega$	nH	mm		g	
<b><math>V_R = \text{AC } 900 \text{ V}</math></b>			<b><math>\hat{v} = 1100 \text{ V}</math></b>			<b><math>v_s = 1500 \text{ V}</math></b>		<b><math>V_{\text{TT}} = \text{AC } 1150 \text{ V, } 10 \text{ s}</math></b>	
0.22	10	90	220	15.0	110	25 × 57	1	40	B25835M6224K007
0.33	10	130	330	11.0	110	25 × 57	1	40	B25835M6334K007
0.47	10	100	250	19.0	110	25 × 57	1	40	B25835M6474K007
0.68	18	150	370	14.0	110	30 × 57	1	50	B25835M6684K007
1.00	18	220	550	10.0	110	30 × 57	1	50	B25835M6105K007
2.20	18	480	1200	6.6	110	45 × 57	1	110	B25835M6225K007
4.70	18	1000	2500	4.6	110	60 × 57	1	190	B25835M6475K007
<b><math>V_R = \text{AC } 1400 \text{ V}</math></b>			<b><math>\hat{v} = 1800 \text{ V}</math></b>			<b><math>v_s = 2400 \text{ V}</math></b>		<b><math>V_{\text{TT}} = \text{AC } 1800 \text{ V, } 10 \text{ s}</math></b>	
0.10	10	150	380	20.0	110	25 × 57	2	40	B25835M0104K007
0.22	10	220	550	18.0	140	25 × 70	1	50	B25835M0224K007
0.33	10	200	500	27.0	190	25 × 95	1	60	B25835M0334K007
0.47	18	280	700	20.0	190	30 × 95	1	90	B25835M0474K007
0.68	18	400	1000	15.0	190	30 × 95	1	90	B25835M0684K007
1.00	18	600	1500	12.0	190	35 × 95	1	110	B25835M0105K007
2.20	18	1300	3300	7.6	190	50 × 95	1	220	B25835M0225K007
<b><math>V_R = \text{AC } 1700 \text{ V}</math></b>			<b><math>\hat{v} = 2100 \text{ V}</math></b>			<b><math>v_s = 2900 \text{ V}</math></b>		<b><math>V_{\text{TT}} = \text{AC } 2100 \text{ V, } 10 \text{ s}</math></b>	
0.10	10	200	500	16.0	110	25 × 57	2	40	B25835M7104K007
0.22	10	300	750	15.0	140	25 × 70	1	50	B25835M7224K007
0.47	18	660	1600	8.4	140	35 × 70	1	90	B25835M7474K007

1) Other capacitance values upon request

**Damping**
**Characteristics and ordering codes**

$C_R^{1)}$	$I_{\max}$	$\hat{i}$	$I_s$	$R_S$ 20 °C	$L_{\text{self}}$	Dimensions $d \times l$	Fig.	Appr. weight	Ordering code
$\mu\text{F}$	A	A	A	m $\Omega$	nH	mm		g	
<b><math>V_R = \text{AC } 2100 \text{ V}</math></b>									
<b><math>\hat{v} = 2600 \text{ V}</math></b>									
<b><math>v_s = 3600 \text{ V}</math></b>									
<b><math>V_{TT} = \text{AC } 2600 \text{ V, } 10 \text{ s}</math></b>									
0.47	18	750	1900	11.0	190	35 × 95	2	110	B25835M1474K007
0.68	18	1100	2700	8.7	190	40 × 95	1	140	B25835M1684K007
1.00	18	1600	4000	7.1	190	45 × 95	1	180	B25835M1105K007
2.20	18	1100	2800	13.0	250	60 × 131	1	440	B25835M1225K007
<b><math>V_R = \text{AC } 3400 \text{ V}</math></b>									
<b><math>\hat{v} = 4300 \text{ V}</math></b>									
<b><math>v_s = 5800 \text{ V}</math></b>									
<b><math>V_{TT} = \text{AC } 4300 \text{ V, } 10 \text{ s}</math></b>									
0.10	18	280	700	33.0	250	35 × 131	1	150	B25835M2104K007
0.15	18	400	1000	24.0	250	35 × 131	1	150	B25835M2154K007
0.22	18	600	1500	18.0	250	35 × 131	1	150	B25835M2224K007
0.33	18	900	2300	15.0	250	50 × 131	1	300	B25835M2334K007
0.47	18	1300	3300	12.0	250	50 × 131	1	300	B25835M2474K007
0.68	18	1900	4800	11.0	250	60 × 131	1	440	B25835M2684K007

1) Other capacitance values upon request

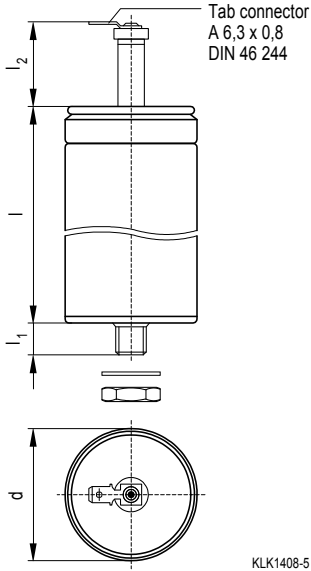
**Damping**
**Dimensional drawing**

$d^{+0.5}_{-0.2}$	$l^{+1}_{-2}$	$l_1 + 1^*$	$l_{2max}$	Creepage distance	Clearance
mm	mm	mm	mm	mm	mm
25	57	8	15	6	6
25	57	8	23	14	14
25	70	8	23	14	14
25	95	8	23	14	14
30	57	8	15	6	6
30	95	8	23	14	14
35	70	8	26	14	14
35	95	8	26	14	14
35	95	8	32	20	20
35	131	8	32	20	20
40	95	8	32	20	20
45	57	8	22	10	10
45	95	8	32	20	20
50	95	12	26	14	14
50	131	12	32	20	20
60	57	12	22	10	10
60	131	12	32	20	20

\*) 8 mm =threaded bolt M8  
12 mm =threaded bolt M12

**Mounting parts (included in delivery)**

Threaded bolt	Max. torque	Washer	Hex nut
M8	4 Nm	A 8.4 DIN 125-Ms	M 8 DIN 439
M12	10 Nm	A 13 DIN 125-Ms	M12 DIN 439

**Damping****Cautions and warnings****Safety**

- In case of dents of more than 1 mm depth or any other mechanical damage, capacitors must not be used at all. This applies also in cases of oil leakage.
- Electrical or mechanical misapplication of capacitors may be hazardous. Personal injury or property damage may result from bursting of the capacitor or from expulsion of oil or melted material due to mechanical disruption of the capacitor.
- Ensure good, effective grounding for capacitor enclosures.
- Observe appropriate safety precautions during operation (self-recharging phenomena and the high energy contained in capacitors).
- Handle capacitors carefully, because they may still be charged even after disconnection.
- The terminals of capacitors, connected bus bars and cables as well as other devices may also be energized.
- Follow good engineering practice.
- Failure to follow cautions may result, worst case, in premature failures, bursting and fire.

**Thermal load**

After installation of the capacitor it is necessary to verify that maximum hot-spot temperature is not exceeded at extreme service conditions (see [www.epcos.com/thermal\\_design](http://www.epcos.com/thermal_design)).

**Mechanical protection**

The capacitor has to be installed in a way that mechanical damages and dents in the aluminum can are avoided.

**Storage and operating conditions**

Do not use or store capacitors in corrosive atmosphere especially where chloride gas, sulfide gas, acid, alkali, salt or the like are present. In dusty environments, regular maintenance and cleaning especially of the terminals is required to avoid conductive path between phases and/or phases and ground.

**Overpressure disconnecter**

To ensure full functionality of an overpressure disconnecter, the following must be observed:

- The elastic elements must not be hindered, i.e.
  - connecting lines must be flexible leads (cables),
  - there must be sufficient space (minimum 12 mm) above the connections for expansion of the overpressure disconnecter,
  - folding crimps must not be retained by clamps.
- Stress parameters of the capacitor must be within the IEC61071 specification.

**Service life expectancy**

Electrical components do not have an unlimited service life expectancy; this applies to self-healing capacitors too. The maximum service life expectancy may vary depending on the application the capacitor is used in.



## Important notes

The following applies to all products named in this publication:







1. Some parts of this publication contain **statements about the suitability of our products for certain areas of application**. These statements are based on our knowledge of typical requirements that are often placed on our products in the areas of application concerned. We nevertheless expressly point out **that such statements cannot be regarded as binding statements about the suitability of our products for a particular customer application**. As a rule we are either unfamiliar with individual customer applications or less familiar with them than the customers themselves. For these reasons, it is always ultimately incumbent on the customer to check and decide whether a product with the properties described in the product specification is suitable for use in a particular customer application.
2. We also point out that **in individual cases, a malfunction of electronic components or failure before the end of their usual service life cannot be completely ruled out in the current state of the art, even if they are operated as specified**. In customer applications requiring a very high level of operational safety and especially in customer applications in which the malfunction or failure of an electronic component could endanger human life or health (e.g. in accident prevention or life-saving systems), it must therefore be ensured by means of suitable design of the customer application or other action taken by the customer (e.g. installation of protective circuitry or redundancy) that no injury or damage is sustained by third parties in the event of malfunction or failure of an electronic component.
3. **The warnings, cautions and product-specific notes must be observed.**
4. In order to satisfy certain technical requirements, **some of the products described in this publication may contain substances subject to restrictions in certain jurisdictions (e.g. because they are classed as hazardous)**. Useful information on this will be found in our Material Data Sheets on the Internet ([www.tdk-electronics.tdk.com/material](http://www.tdk-electronics.tdk.com/material)). Should you have any more detailed questions, please contact our sales offices.
5. We constantly strive to improve our products. Consequently, **the products described in this publication may change from time to time**. The same is true of the corresponding product specifications. Please check therefore to what extent product descriptions and specifications contained in this publication are still applicable before or when you place an order.  
  
We also **reserve the right to discontinue production and delivery of products**. Consequently, we cannot guarantee that all products named in this publication will always be available. The aforementioned does not apply in the case of individual agreements deviating from the foregoing for customer-specific products.
6. Unless otherwise agreed in individual contracts, **all orders are subject to our General Terms and Conditions of Supply**.
7. **Our manufacturing sites serving the automotive business apply the IATF 16949 standard**. The IATF certifications confirm our compliance with requirements regarding the quality management system in the automotive industry. Referring to customer requirements and customer specific requirements ("CSR") TDK always has and will continue to have the policy of respecting individual agreements. Even if IATF 16949 may appear to support the acceptance of unilateral requirements, we hereby like to emphasize that **only requirements mutually agreed upon can and will be implemented in our Quality Management System**. For clarification purposes we like to point out that obligations from IATF 16949 shall only become legally binding if individually agreed upon.
8. The trade names EPCOS, CeraCharge, CeraDiode, CeraLink, CeraPad, CeraPlas, CSMP, CTVS, DeltaCap, DigiSiMic, ExoCore, FilterCap, FormFit, LeaXield, MiniBlue, MiniCell, MKD, MKK, MotorCap, PCC, PhaseCap, PhaseCube, PhaseMod, PhiCap, PowerHap, PQSine, PQvar, SIFERRIT, SIFI, SIKOREL, SilverCap, SIMDAD, SiMic, SIMID, SineFormer, SIOV, ThermoFuse, WindCap are **trademarks registered or pending** in Europe and in other countries. Further information will be found on the Internet at [www.tdk-electronics.tdk.com/trademarks](http://www.tdk-electronics.tdk.com/trademarks).

# Looking for pricing, stock, or lifecycle information?

Click below to explore more details on WIN SOURCE:

-  [View B25835K1474K7 on WIN SOURCE](#)
-  [EPCOS \(TDK\) Information](#)

## Optimize Your Supply Chain with WIN SOURCE Solutions

-  Global Sourcing Solution
-  Obsolete Management
-  Cost Control Management
-  Shortage Management
-  Alternative Solution
-  Excess Inventory Management