



**THE DATASHEET OF
UCC27524AQDGNRQ1**



UCC27524A-Q1 Dual 5-A, High-Speed, Low-Side Gate Driver With Negative Input Voltage Capability

1 Features

- Qualified for Automotive Applications
- AEC-Q100 Qualified With the Following Results
 - Device Temperature Grade 1
 - Device HBM ESD Classification Level H2
 - Device CDM ESD Classification Level C4B
- Industry-Standard Pin Out
- Two Independent Gate-Drive Channels
- 5-A Peak Source and Sink-Drive Current
- Independent Enable Function for Each Output
- TTL and CMOS-Compatible Logic Threshold Independent of Supply Voltage
- Hysteretic-Logic Thresholds for High-Noise Immunity
- Ability to Handle Negative Voltages (–5 V) at Inputs
- Inputs and Enable Pin-Voltage Levels Not Restricted by V_{DD} Pin Bias Supply Voltage
- 4.5-V to 18-V Single-Supply Range
- Outputs Held Low During V_{DD} -UVLO, (ensures glitch-free operation at power-up and power-down)
- Fast Propagation Delays (13-ns typical)
- Fast Rise and Fall Times (7-ns and 6-ns typical)
- 1-ns Typical Delay Matching Between 2-Channels
- Ability to Parallel Two Outputs for High-Drive Current
- Outputs Held in LOW When Inputs are Floating
- SOIC-8 and MSOP-8 PowerPad™ Package Options
- Operating Temperature Range of –40°C to 140°C

2 Applications

- Automotive
- Switch-Mode Power Supplies
- DC-to-DC Converters
- Motor Control, Solar Power
- Gate Drive for Emerging Wide Band-Gap Power Devices such as GaN

3 Description

The UCC27524A-Q1 device is a dual-channel, high-speed, low-side, gate-driver device capable of effectively driving MOSFET and IGBT power switches. The UCC27524A-Q1 device is a variant of the UCC2752x family. The UCC27524A-Q1 device adds the ability to handle –5 V directly at the input pins for increased robustness. The UCC27524A-Q1 device is a dual, non-inverting driver. Using a design that inherently minimizes shoot-through current, the UCC27524A-Q1 device is capable of delivering high-peak current pulses of up to 5-A source and 5-A sink into capacitive loads along with rail-to-rail drive capability and extremely small propagation delay (typically 13 ns). In addition, the drivers feature matched, internal-propagation delays between the two channels which are very well suited for applications requiring dual-gate drives with critical timing, such as synchronous rectifiers. This also enables connecting two channels in parallel to effectively increase current-drive capability or driving two switches in parallel with a single input signal. The input pin thresholds are based on TTL and CMOS compatible low-voltage logic, which is fixed and independent of the V_{DD} supply voltage. Wide hysteresis between the high and low thresholds offers excellent noise immunity.

Device Information⁽¹⁾

| PART NUMBER | PACKAGE | BODY SIZE (NOM) |
|--------------|-------------------|-------------------|
| UCC27524A-Q1 | SOIC (8) | 4.90 mm x 3.91 mm |
| | MSOP-PowerPAD (8) | 3.00 mm x 3.00 mm |

(1) For all available packages, see the orderable addendum at the end of the data sheet.

Product Matrix

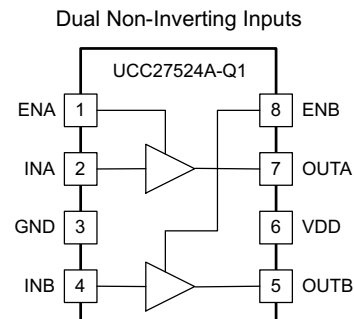

Table of Contents

| | |
|--|---|
| 1 Features 1 2 Applications 1 3 Description 1 4 Revision History 2 5 Description (continued) 3 6 Pin Configuration and Functions 4 7 Specifications 5 7.1 Absolute Maximum Ratings 5 7.2 ESD Ratings 5 7.3 Recommended Operating Conditions 5 7.4 Thermal Information 5 7.5 Electrical Characteristics 6 7.6 Switching Characteristics 6 7.7 Typical Characteristics 8 8 Detailed Description 11 8.1 Overview 11 8.2 Functional Block Diagram 12 | 8.3 Feature Description 12 8.4 Device Functional Modes 17 9 Application and Implementation 18 9.1 Application Information 18 9.2 Typical Application 18 10 Power Supply Recommendations 22 11 Layout 23 11.1 Layout Guidelines 23 11.2 Layout Example 24 11.3 Thermal Considerations 24 12 Device and Documentation Support 25 12.1 Community Resources 25 12.2 Trademarks 25 12.3 Electrostatic Discharge Caution 25 12.4 Glossary 25 13 Mechanical, Packaging, and Orderable Information 25 |
|--|---|

4 Revision History

NOTE: Page numbers for previous revisions may differ from page numbers in the current version.

| Changes from Revision A (January 2014) to Revision B | Page |
|--|------|
| <ul style="list-style-type: none"> • Added <i>ESD Rating</i> table, <i>Feature Description</i> section, <i>Device Functional Modes</i>, <i>Application and Implementation</i> section, <i>Power Supply Recommendations</i> section, <i>Layout</i> section, <i>Device and Documentation Support</i> section, and <i>Mechanical, Packaging, and Orderable Information</i> section. | 1 |

| Changes from Original (November 2013) to Revision A | Page |
|--|------|
| <ul style="list-style-type: none"> • Changed document status from <i>Product Preview</i> to <i>Production Data</i>..... | 1 |

5 Description (continued)

For protection purposes, internal pull-up and pull-down resistors on the input pins of the UCC27524A-Q1 device ensure that outputs are held LOW when input pins are in floating condition. The UCC27524A-Q1 device features enable pins (ENA and ENB) to have better control of the operation of the driver applications. The pins are internally pulled up to V_{DD} for active-high logic and are left open for standard operation.

The UCC27524A-Q1 devices is available in SOIC-8 (D) and MSOP-PowerPAD-8 with exposed pad (DGN) packages.

6 Pin Configuration and Functions

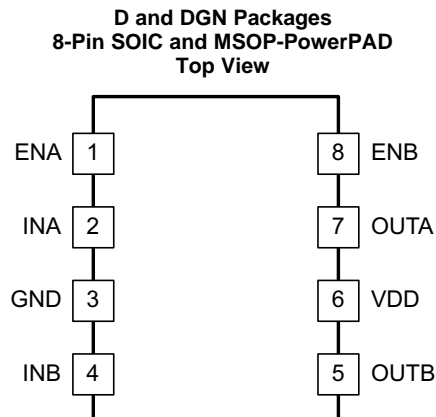

Pin Functions

| PIN | | I/O | DESCRIPTION |
|------|-----|-----|---|
| NAME | NO. | | |
| ENA | 1 | I | Enable input for Channel A: ENA is biased LOW to disable the Channel A output regardless of the INA state. ENA is biased HIGH or left floating to enable the Channel A output. ENA is allowed to float; hence the pin-to-pin compatibility with the UCC2732X N/C pin. |
| ENB | 8 | I | Enable input for Channel B: ENB is biased LOW to disables the Channel B output regardless of the INB state. ENB is biased HIGH or left floating to enable Channel B output. ENB is allowed to float hence; the pin-to-pin compatibility with the UCC2752A N/C pin. |
| GND | 3 | - | Ground: All signals are referenced to this pin. |
| INA | 2 | I | Input to Channel A: INA is the non-inverting input in the UCC27524A-Q1 device. OUTA is held LOW if INA is unbiased or floating. |
| INB | 4 | I | Input to Channel B: INB is the non-inverting input in the UCC27524A-Q1 device. OUTB is held LOW if INB is unbiased or floating. |
| OUTA | 7 | O | Output of Channel A |
| OUTB | 5 | O | Output of Channel B |
| VDD | 6 | I | Bias supply input |

7 Specifications

7.1 Absolute Maximum Ratings

over operating free-air temperature range (unless otherwise noted)⁽¹⁾

| | | MIN | MAX | UNIT |
|--|--|------|-----------|------|
| Supply voltage | VDD | -0.3 | 20 | V |
| OUTA, OUTB voltage | DC | -0.3 | VDD + 0.3 | V |
| | Repetitive pulse < 200 ns ⁽²⁾ | -2 | VDD + 0.3 | V |
| Output continuous source/sink current | I _{OUT_DC} | | 0.3 | A |
| Output pulsed source/sink current (0.5 μs) | I _{OUT_pulsed} | | 5 | A |
| INA, INB, ENA, ENB voltage ⁽³⁾ | | -5 | 20 | V |
| Operating virtual junction temperature, T _J | | -40 | 150 | °C |
| Storage temperature, T _{stg} | | -65 | 150 | °C |

- (1) Stresses beyond those listed under *Absolute Maximum Ratings* may cause permanent damage to the device. These are stress ratings only, which do not imply functional operation of the device at these or any other conditions beyond those indicated under *Recommended Operating Conditions*. Exposure to absolute-maximum-rated conditions for extended periods may affect device reliability.
- (2) Values are verified by characterization on bench.
- (3) The maximum voltage on the Input and Enable pins is not restricted by the voltage on the VDD pin.

7.2 ESD Ratings

| | | VALUE | UNIT |
|--|---|-------|------|
| V _(ESD) Electrostatic discharge | Human-body model (HBM), per AEC Q100-002 ⁽¹⁾ | ±2000 | V |
| | Charged-device model (CDM), per AEC Q100-011 | ±750 | |

- (1) AEC Q100-002 indicates that HBM stressing shall be in accordance with the ANSI/ESDA/JEDEC JS-001 specification.

7.3 Recommended Operating Conditions

over operating free-air temperature range (unless otherwise noted)

| | | MIN | NOM | MAX | UNIT |
|--------------------------------|--|-----|-----|-----|------|
| Supply voltage, VDD | | 4.5 | 12 | 18 | V |
| Operating junction temperature | | -40 | | 140 | °C |
| Input voltage, INA, INB | | -2 | | 18 | V |
| Enable voltage, ENA and ENB | | -2 | | 18 | V |

7.4 Thermal Information

| THERMAL METRIC ⁽¹⁾ | | UCC27524A-Q1 | UCC27524A-Q1 | UNIT |
|-------------------------------|--|--------------|--------------|------|
| | | SOIC (D) | HVSSOP (DGN) | |
| | | 8 PINS | 8 PINS | |
| R _{θJA} | Junction-to-ambient thermal resistance | 130.9 | 71.8 | °C/W |
| R _{θJC(top)} | Junction-to-case (top) thermal resistance | 80 | 65.6 | °C/W |
| R _{θJB} | Junction-to-board thermal resistance | 71.4 | 7.4 | °C/W |
| ψ _{JT} | Junction-to-top characterization parameter | 21.9 | 7.4 | °C/W |
| ψ _{JB} | Junction-to-board characterization parameter | 70.9 | 31.5 | °C/W |
| R _{θJC(bot)} | Junction-to-case (bottom) thermal resistance | n/a | 19.6 | °C/W |

- (1) For more information about traditional and new thermal metrics, see the *Semiconductor and IC Package Thermal Metrics* application report, [SPRA953](#).

7.5 Electrical Characteristics

$V_{DD} = 12\text{ V}$, $T_A = T_J = -40\text{ }^\circ\text{C}$ to $140\text{ }^\circ\text{C}$, 1- μF capacitor from V_{DD} to GND. Currents are positive into, negative out of the specified terminal (unless otherwise noted.)

| PARAMETER | | TEST CONDITIONS | MIN | TYP | MAX | UNIT |
|---|--|---|------|---------|-------|---------------|
| BIAS CURRENTS | | | | | | |
| $I_{DD(off)}$ | Startup current, (based on UCC27524 Input configuration) | $V_{DD} = 3.4\text{ V}$, $INA = V_{DD}$, $INB = V_{DD}$ | 55 | 110 | 175 | μA |
| | | $V_{DD} = 3.4\text{ V}$, $INA = \text{GND}$, $INB = \text{GND}$ | 25 | 75 | 145 | |
| UNDER VOLTAGE LOCKOUT (UVLO) | | | | | | |
| V_{ON} | Supply start threshold | $T_J = 25\text{ }^\circ\text{C}$ | 3.91 | 4.2 | 4.5 | V |
| | | $T_J = -40\text{ }^\circ\text{C}$ to $140\text{ }^\circ\text{C}$ | 3.7 | 4.2 | 4.65 | |
| V_{OFF} | Minimum operating voltage after supply start | | 3.4 | 3.9 | 4.4 | V |
| V_{DD_H} | Supply voltage hysteresis | | 0.2 | 0.3 | 0.5 | V |
| INPUTS (INA, INB, INA+, INA-, INB+, INB-), UCC27524A-Q1 (D, DGN) | | | | | | |
| V_{IN_H} | Input signal high threshold | Output high for non-inverting input pins Output low for inverting input pins | 1.9 | 2.1 | 2.3 | V |
| V_{IN_L} | Input signal low threshold | Output low for non-inverting input pins Output high for inverting input pins | 1 | 1.2 | 1.4 | V |
| V_{IN_HYS} | Input hysteresis | | 0.7 | 0.9 | 1.1 | V |
| OUTPUTS (OUTA, OUTB) | | | | | | |
| $I_{SNK/SRC}$ | Sink/source peak current ⁽¹⁾ | $C_{LOAD} = 0.22\text{ }\mu\text{F}$, $F_{SW} = 1\text{ kHz}$ | | ± 5 | | A |
| $V_{DD}-V_{OH}$ | High output voltage | $I_{OUT} = -10\text{ mA}$ | | | 0.075 | V |
| V_{OL} | Low output voltage | $I_{OUT} = 10\text{ mA}$ | | | 0.01 | V |
| R_{OH} | Output pullup resistance ⁽²⁾ | $I_{OUT} = -10\text{ mA}$ | 2.5 | 5 | 7.5 | Ω |
| R_{OL} | Output pulldown resistance | $I_{OUT} = 10\text{ mA}$ | 0.15 | 0.5 | 1 | Ω |

(1) Ensured by design.

(2) R_{OH} represents on-resistance of only the P-Channel MOSFET device in the pullup structure of the UCC27524A-Q1 output stage.

7.6 Switching Characteristics

over operating free-air temperature range (unless otherwise noted)

| PARAMETER | | TEST CONDITIONS | MIN | TYP | MAX | UNIT |
|---------------------|---|---|-----|-----|-----|------|
| t_R | Rise time ⁽¹⁾ | $C_{LOAD} = 1.8\text{ nF}$ | | 7 | 18 | ns |
| t_F | Fall time ⁽¹⁾ | $C_{LOAD} = 1.8\text{ nF}$ | | 6 | 10 | ns |
| t_M | Delay matching between 2 channels | $INA = INB$, OUTA and OUTB at 50% transition point | | 1 | 4 | ns |
| t_{PW} | Minimum input pulse width that changes the output state | | | 15 | 25 | ns |
| t_{D1} , t_{D2} | Input to output propagation delay ⁽¹⁾ | $C_{LOAD} = 1.8\text{ nF}$, 5-V input pulse | 6 | 13 | 23 | ns |
| t_{D3} , t_{D4} | EN to output propagation delay ⁽¹⁾ | $C_{LOAD} = 1.8\text{ nF}$, 5-V enable pulse | 6 | 13 | 23 | ns |

(1) See the timing diagrams in [Figure 1](#) and [Figure 2](#)

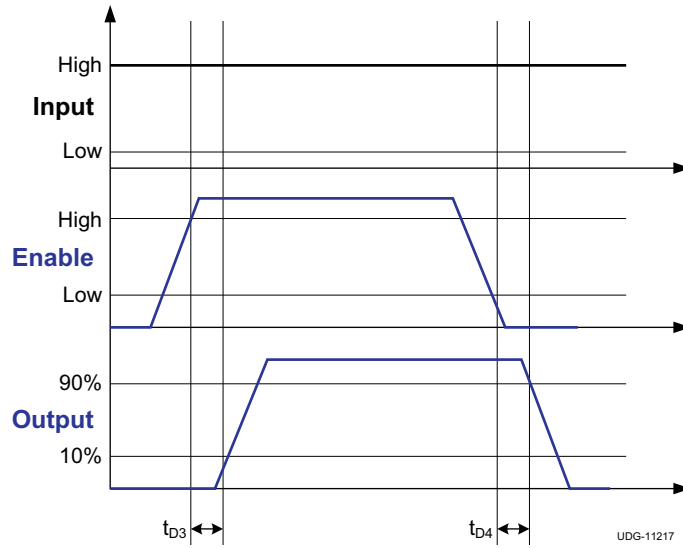

Figure 1. Enable Function

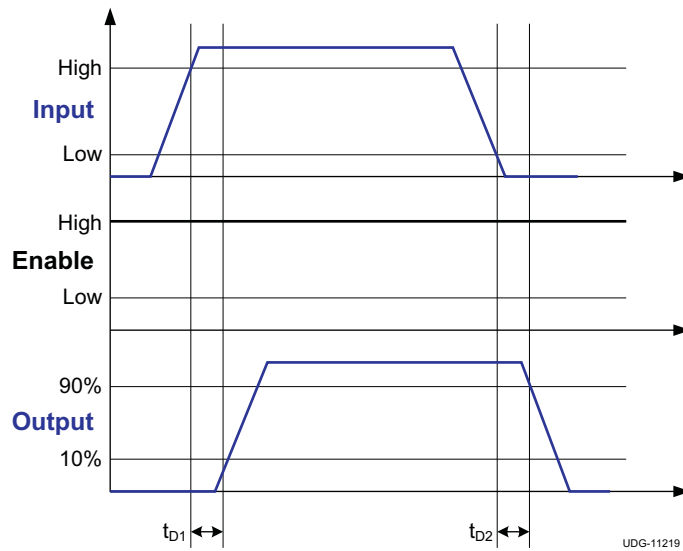
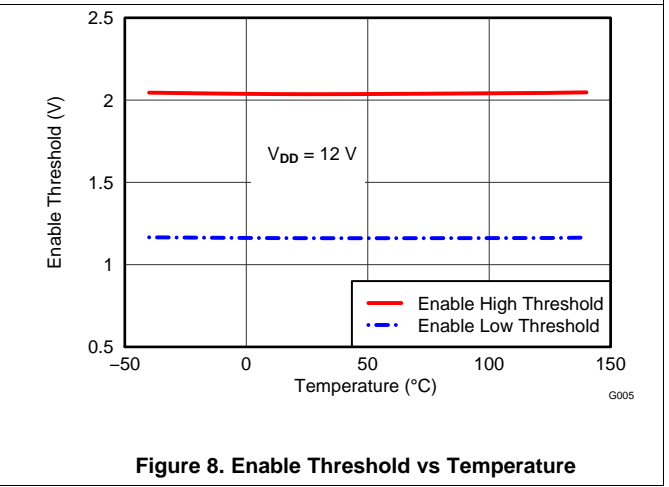
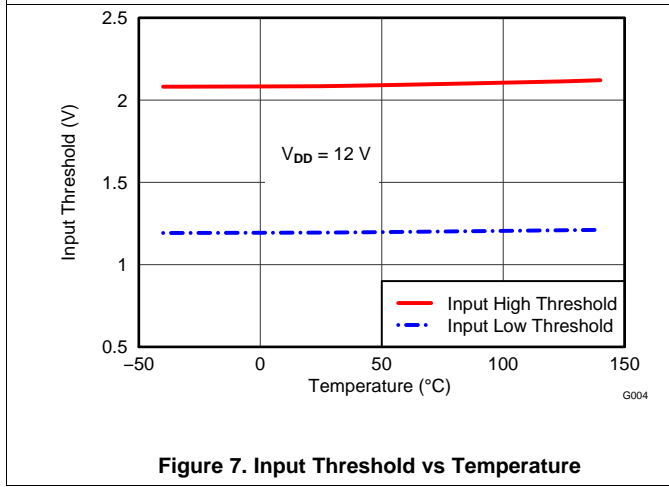
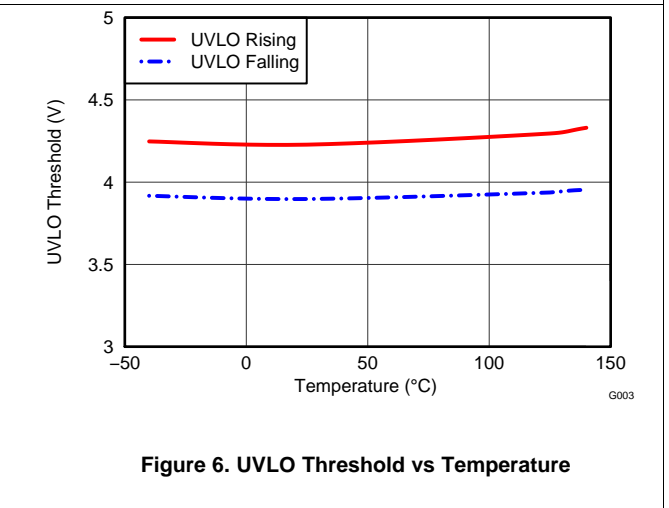
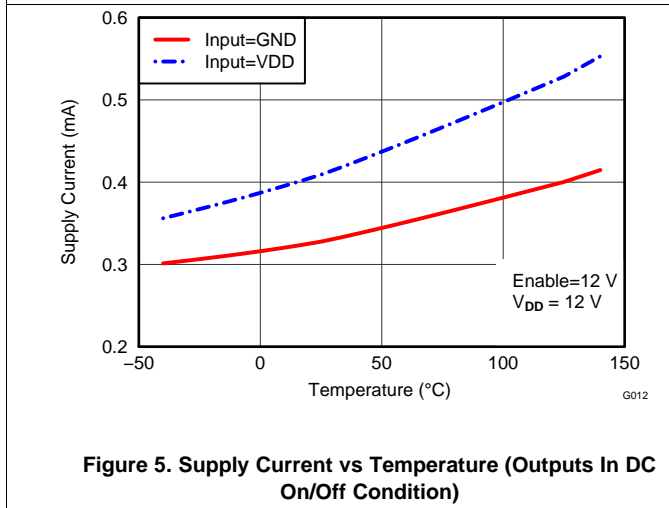
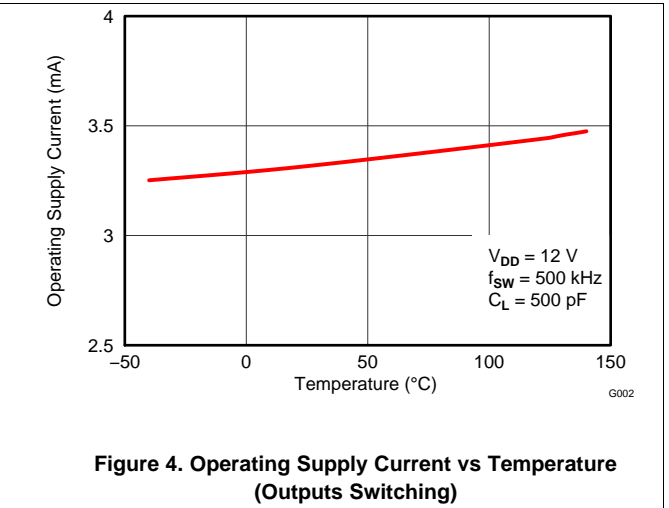
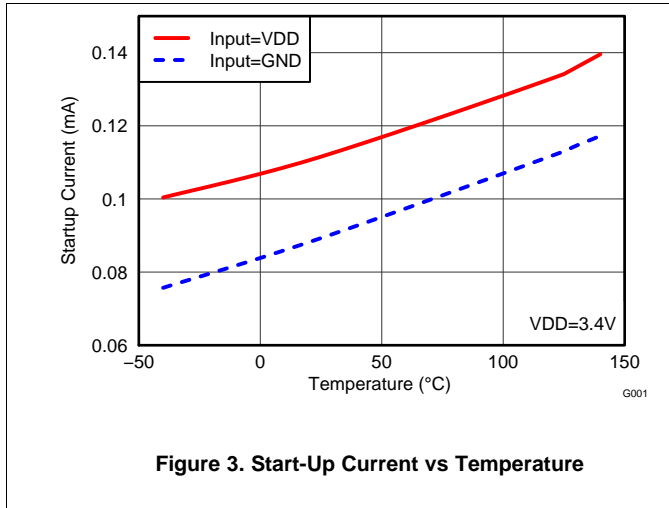

Figure 2. Input-Output Operation

7.7 Typical Characteristics



Typical Characteristics (continued)

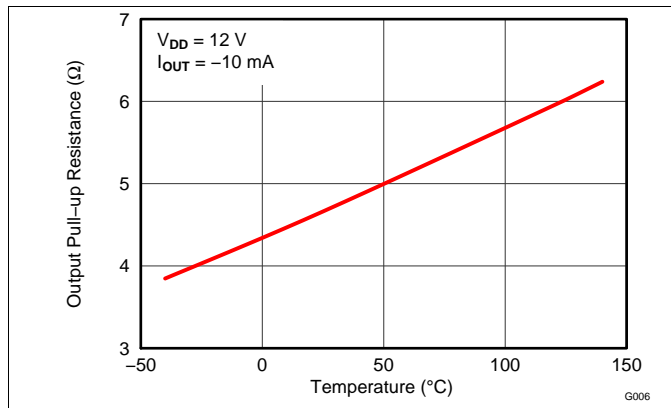

Figure 9. Output Pullup Resistance vs Temperature

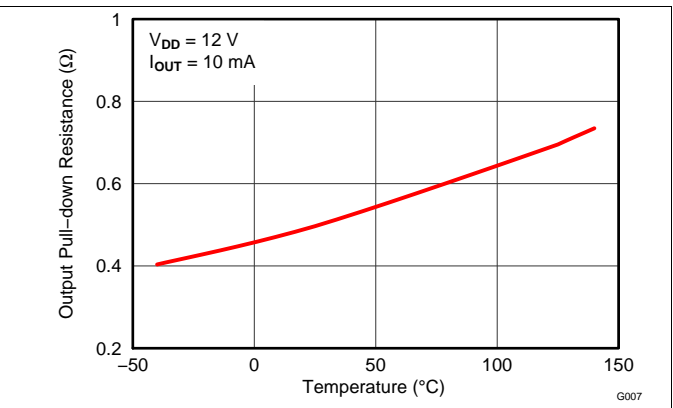

Figure 10. Output Pulldown Resistance vs Temperature

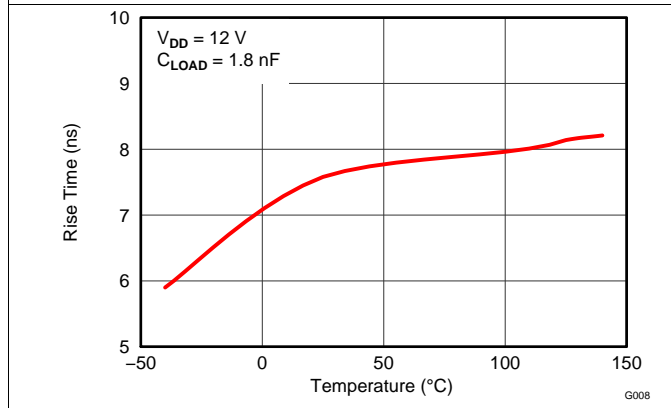

Figure 11. Rise Time vs Temperature

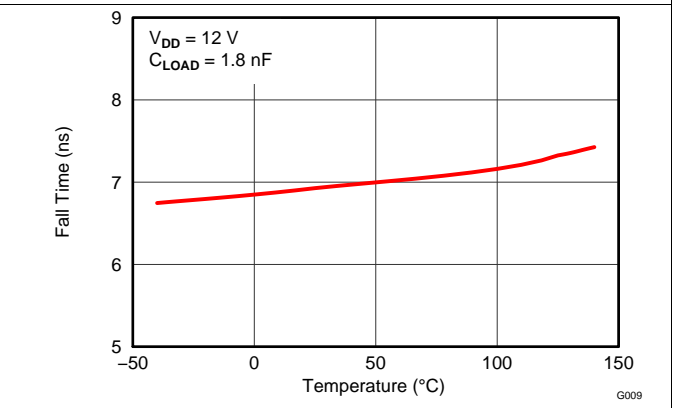

Figure 12. Fall Time vs Temperature

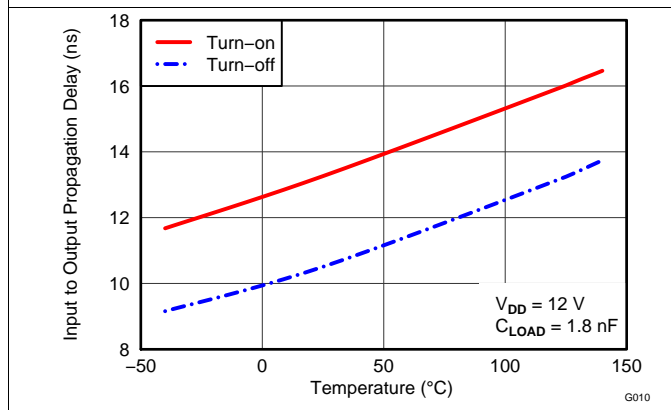

Figure 13. Input to Output Propagation Delay vs Temperature

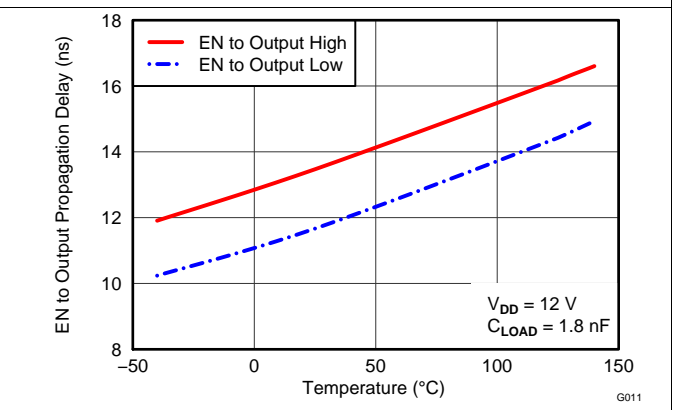

Figure 14. En to Output Propagation Delay vs Temperature

Typical Characteristics (continued)

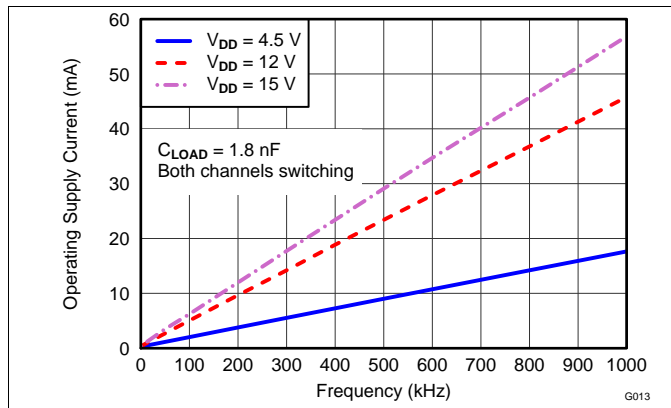

Figure 15. Operating Supply Current vs Frequency

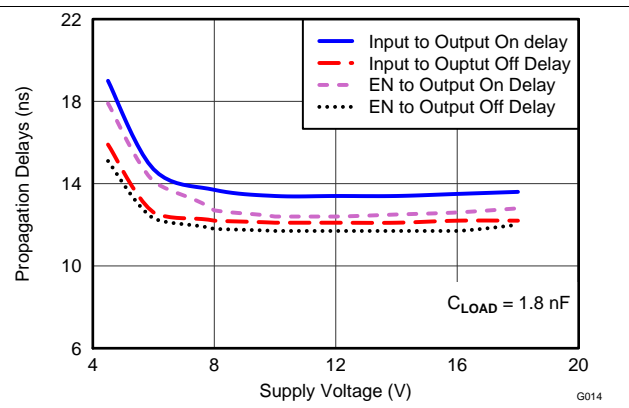

Figure 16. Propagation Delays vs Supply Voltage

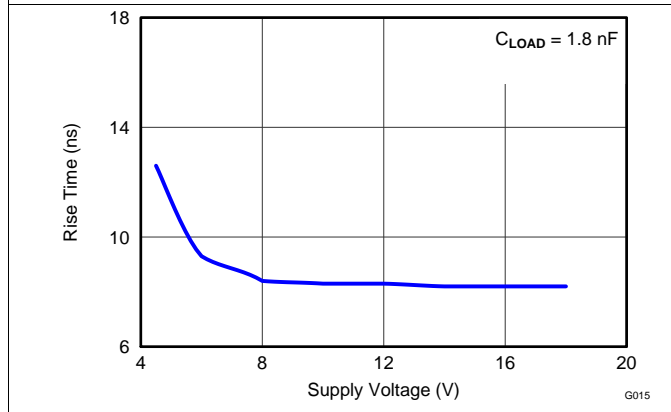

Figure 17. Rise Time vs Supply Voltage

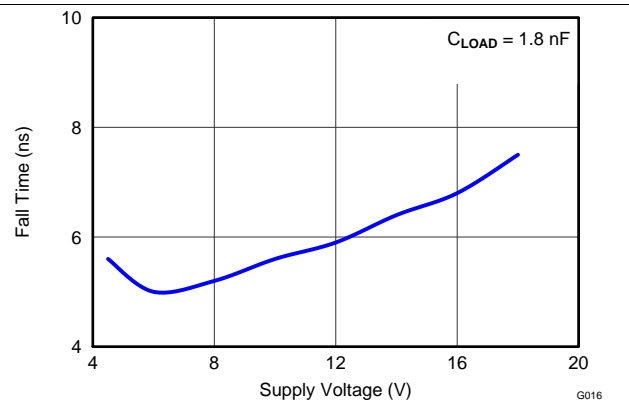

Figure 18. Fall Time vs Supply Voltage

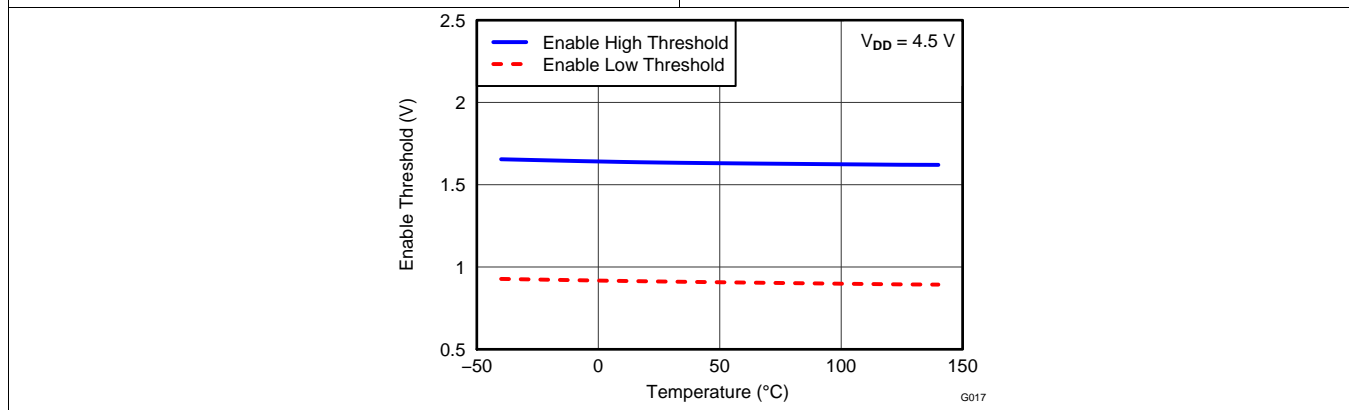

Figure 19. Enable Threshold vs Temperature

8 Detailed Description

8.1 Overview

The UCC27524A-Q1 device represents Texas Instruments' latest generation of dual-channel, low-side, high-speed, gate-driver devices featuring a 5-A source and sink current capability, industry best-in-class switching characteristics, and a host of other features listed in [Table 1](#) all of which combine to ensure efficient, robust and reliable operation in high-frequency switching power circuits.

Table 1. UCC27524A-Q1 Features and Benefits

| FEATURE | BENEFIT |
|--|--|
| Best-in-class 13-ns (typ) propagation delay | Extremely low-pulse transmission distortion |
| 1-ns (typ) delay matching between channels | Ease of paralleling outputs for higher (2 times) current capability, ease of driving parallel-power switches |
| Expanded VDD Operating range of 4.5 to 18 V | Flexibility in system design |
| Expanded operating temperature range of $-40\text{ }^{\circ}\text{C}$ to $+140\text{ }^{\circ}\text{C}$ (See Electrical Characteristics table) | Flexibility in system design |
| VDD UVLO Protection | Outputs are held Low in UVLO condition, which ensures predictable, glitch-free operation at power-up and power-down |
| Outputs held Low when input pins (INx) in floating condition | Protection feature, especially useful in passing abnormal condition tests during safety certification |
| Outputs enable when enable pins (ENx) in floating condition | Pin-to-pin compatibility with the UCC27324 device from Texas Instruments, in designs where Pin 1 and Pin 8 are in floating condition |
| CMOS/TTL compatible input and enable threshold with wide hysteresis | Enhanced noise immunity, while retaining compatibility with microcontroller logic-level input signals (3.3 V, 5 V) optimized for digital power |
| Ability of input and enable pins to handle voltage levels not restricted by VDD pin bias voltage | System simplification, especially related to auxiliary bias supply architecture |
| Ability to handle -5 V_{DC} (max) at input pins | Increased robustness in noisy environments |

8.2 Functional Block Diagram

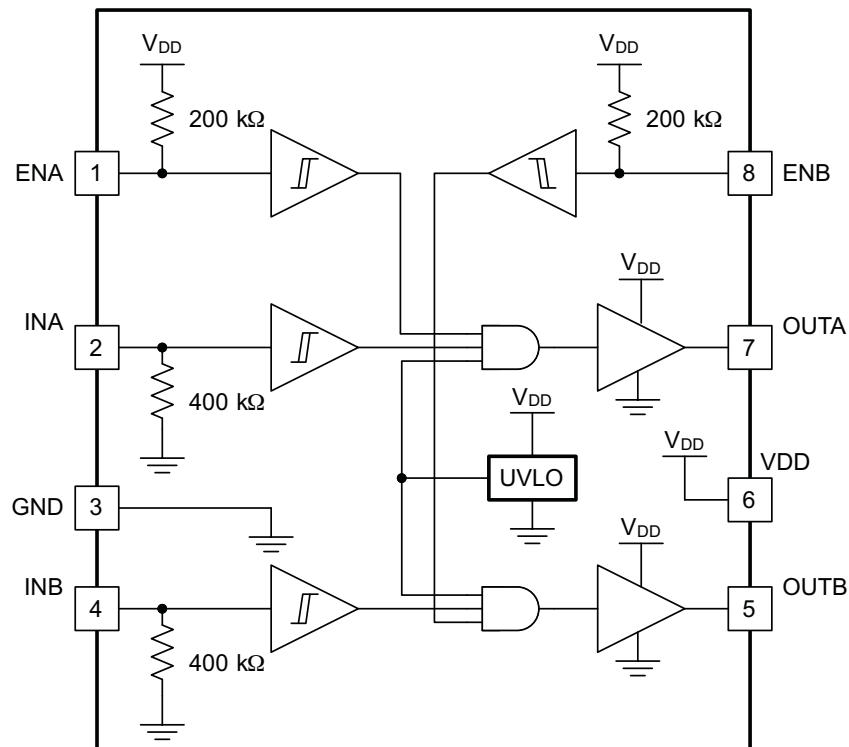

8.3 Feature Description

8.3.1 Operating Supply Current

The UCC27524A-Q1 devices feature very low quiescent I_{DD} currents. The typical operating-supply current in UVLO state and fully-on state (under static and switching conditions) are summarized in [Figure 3](#), [Figure 4](#) and [Figure 5](#). The I_{DD} current when the device is fully on and outputs are in a static state (DC high or DC low, see [Figure 4](#)) represents lowest quiescent I_{DD} current when all the internal logic circuits of the device are fully operational. The total supply current is the sum of the quiescent I_{DD} current, the average I_{OUT} current because of switching, and finally any current related to pullup resistors on the enable pins (see [Functional Block Diagram](#)). Knowing the operating frequency (f_{SW}) and the MOSFET gate (Q_G) charge at the drive voltage being used, the average I_{OUT} current can be calculated as product of Q_G and f_{SW} .

A complete characterization of the I_{DD} current as a function of switching frequency at different V_{DD} bias voltages under 1.8-nF switching load in both channels is provided in [Figure 15](#). The strikingly linear variation and close correlation with theoretical value of average I_{OUT} indicates negligible shoot-through inside the gate-driver device attesting to its high-speed characteristics.

Feature Description (continued)

8.3.2 Input Stage

The input pins of the UCC27524A-Q1 gate-driver devices are based on a TTL and CMOS compatible input-threshold logic that is independent of the VDD supply voltage. With typically high threshold = 2.1 V and typically low threshold = 1.2 V, the logic level thresholds are conveniently driven with PWM control signals derived from 3.3-V and 5-V digital power-controller devices. Wider hysteresis (typ 0.9 V) offers enhanced noise immunity compared to traditional TTL logic implementations, where the hysteresis is typically less than 0.5 V. UCC27524A-Q1 devices also feature tight control of the input pin threshold voltage levels which eases system design considerations and ensures stable operation across temperature (refer to [Figure 7](#)). The very low input capacitance on these pins reduces loading and increases switching speed.

The UCC27524A-Q1 device features an important protection feature that holds the output of a channel when the respective pin is in a floating condition. This is achieved using GND pulldown resistors on all of the non-inverting input pins (INA, INB), as shown in the device block diagrams.

The input stage of each driver is driven by a signal with a short rise or fall time. This condition is satisfied in typical power supply applications, where the input signals are provided by a PWM controller or logic gates with fast transition times (<200 ns) with a slow changing input voltage, the output of the driver may switch repeatedly at a high frequency. While the wide hysteresis offered in UCC27524A-Q1 definitely alleviates this concern over most other TTL input threshold devices, extra care is necessary in these implementations. If limiting the rise or fall times to the power device is the primary goal, then an external resistance is highly recommended between the output of the driver and the power device. This external resistor has the additional benefit of reducing part of the gate-charge related power dissipation in the gate driver device package and transferring it into the external resistor itself.

8.3.3 Enable Function

The enable function is an extremely beneficial feature in gate-driver devices, especially for certain applications such as synchronous rectification where the driver outputs disable in light-load conditions to prevent negative current circulation and to improve light-load efficiency.

The UCC27524A-Q1 device is equipped with independent enable pins (ENx) for exclusive control of each driver-channel operation. The enable pins are based on a non-inverting configuration (active-high operation). Thus when ENx pins are driven high, the drivers are enabled and when ENx pins are driven low, the drivers are disabled. Like the input pins, the enable pins are also based on a TTL and CMOS compatible, input-threshold logic that is independent of the supply voltage and are effectively controlled using logic signals from 3.3-V and 5-V microcontrollers. The UCC27524A-Q1 devices also feature tight control of the enable-function threshold-voltage levels which eases system design considerations and ensures stable operation across temperature (refer to [Figure 8](#)). The ENx pins are internally pulled up to VDD using pullup resistors as a result of which the outputs of the device are enabled in the default state. Hence the ENx pins are left floating or Not Connected (N/C) for standard operation, where the enable feature is not needed. Essentially, this floating allows the UCC27524A-Q1 device to be pin-to-pin compatible with TI's previous generation of drivers (UCC27323, UCC27324, and UCC27325 respectively), where Pin 1 and Pin 8 are N/C pins. If the channel A and Channel B inputs and outputs are connected in parallel to increase the driver current capacity, ENA and ENB are connected and driven together.

8.3.4 Output Stage

The UCC27524A-Q1 device output stage features a unique architecture on the pullup structure which delivers the highest peak-source current when it is most needed during the Miller plateau region of the power-switch turnon transition (when the power switch drain or collector voltage experiences dV/dt). The output stage pullup structure features a P-Channel MOSFET and an additional N-Channel MOSFET in parallel. The function of the N-Channel MOSFET is to provide a brief boost in the peak sourcing current enabling fast turnon. This is accomplished by briefly turning-on the N-Channel MOSFET during a narrow instant when the output is changing state from Low to High.

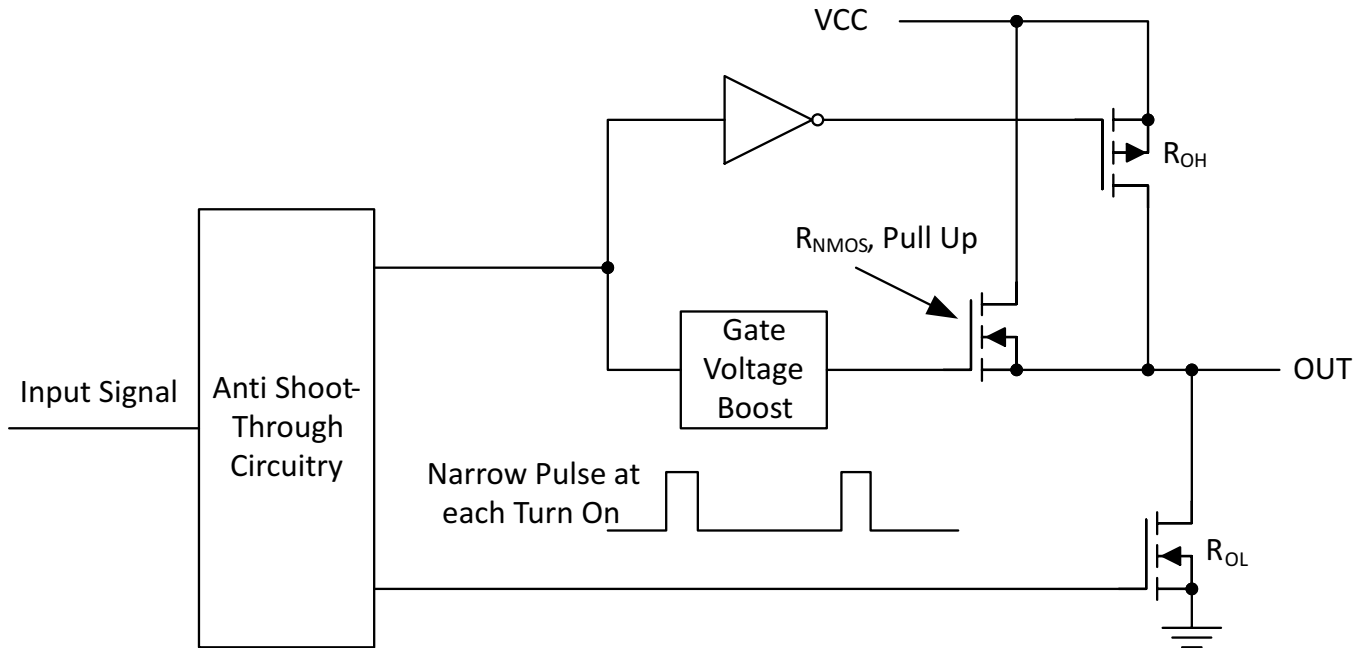
Feature Description (continued)

Figure 20. UCC27524A-Q1 Gate Driver Output Structure

The R_{OH} parameter (see [Electrical Characteristics](#)) is a DC measurement and it is representative of the on-resistance of the P-Channel device only. This is because the N-Channel device is held in the off state in DC condition and is turned-on only for a narrow instant when output changes state from low to high. Note that effective resistance of the UCC27524A-Q1 pullup stage during the turnon instant is much lower than what is represented by R_{OH} parameter.

The pulldown structure in the UCC27524A-Q1 device is simply composed of a N-Channel MOSFET. The R_{OL} parameter (see [Electrical Characteristics](#)), which is also a DC measurement, is representative of the impedance of the pulldown stage in the device. In the UCC27524A-Q1 device, the effective resistance of the hybrid pullup structure during turnon is estimated to be approximately $1.5 \times R_{OL}$, estimated based on design considerations.

Each output stage in the UCC27524A-Q1 device is capable of supplying 5-A peak source and 5-A peak sink current pulses. The output voltage swings between VDD and GND providing rail-to-rail operation, thanks to the MOS-output stage which delivers very low drop-out. The presence of the MOSFET-body diodes also offers low impedance to switching overshoots and undershoots which means that in many cases, external Schottky-diode clamps may be eliminated. The outputs of these drivers are designed to withstand 500-mA reverse current without either damage to the device or logic malfunction.

The UCC27524A-Q1 device is particularly suited for dual-polarity, symmetrical drive-gate transformer applications where the primary winding of transformer driven by OUTA and OUTB, with inputs INA and INB being driven complementary to each other. This situation is because of the extremely low drop-out offered by the MOS output stage of these devices, both during high (V_{OH}) and low (V_{OL}) states along with the low impedance of the driver output stage, all of which allow alleviate concerns regarding transformer demagnetization and flux imbalance. The low propagation delays also ensure accurate reset for high-frequency applications.

For applications that have zero voltage switching during power MOSFET turnon or turnoff interval, the driver supplies high-peak current for fast switching even though the miller plateau is not present. This situation often occurs in synchronous rectifier applications because the body diode is generally conducting before power MOSFET is switched on.

Feature Description (continued)

8.3.5 Low Propagation Delays And Tightly Matched Outputs

The UCC27524A-Q1 driver device features a best in class, 13-ns (typical) propagation delay between input and output which goes to offer the lowest level of pulse-transmission distortion available in the industry for high frequency switching applications. For example in synchronous rectifier applications, the SR MOSFETs are driven with very low distortion when a single driver device is used to drive both the SR MOSFETs. Further, the driver devices also feature an extremely accurate, 1-ns (typical) matched internal-propagation delays between the two channels which is beneficial for applications requiring dual gate drives with critical timing. For example in a PFC application, a pair of paralleled MOSFETs can be driven independently using each output channel, which the inputs of both channels are driven by a common control signal from the PFC controller device. In this case the 1-ns delay matching ensures that the paralleled MOSFETs are driven in a simultaneous fashion with the minimum of turnon delay difference. Yet another benefit of the tight matching between the two channels is that the two channels are connected together to effectively increase current drive capability, for example A and B channels may be combined into a single driver by connecting the INA and INB inputs together and the OUTA and OUTB outputs together. Then, a single signal controls the paralleled combination.

Caution must be exercised when directly connecting OUTA and OUTB pins together because there is the possibility that any delay between the two channels during turnon or turnoff may result in shoot-through current conduction as shown in Figure 21. While the two channels are inherently very well matched (4-ns Max propagation delay), note that there may be differences in the input threshold voltage level between the two channels which causes the delay between the two outputs especially when slow dV/dt input signals are employed. The following guidelines are recommended whenever the two driver channels are paralleled using direct connections between OUTA and OUTB along with INA and INB:

- Use very fast dV/dt input signals (20 V/ μ s or greater) on INA and INB pins to minimize impact of differences in input thresholds causing delays between the channels.
- INA and INB connections must be made as close to the device pins as possible.

Wherever possible, a safe practice would be to add an option in the design to have gate resistors in series with OUTA and OUTB. This allows the option to use 0- Ω resistors for paralleling outputs directly or to add appropriate series resistances to limit shoot-through current, should it become necessary.

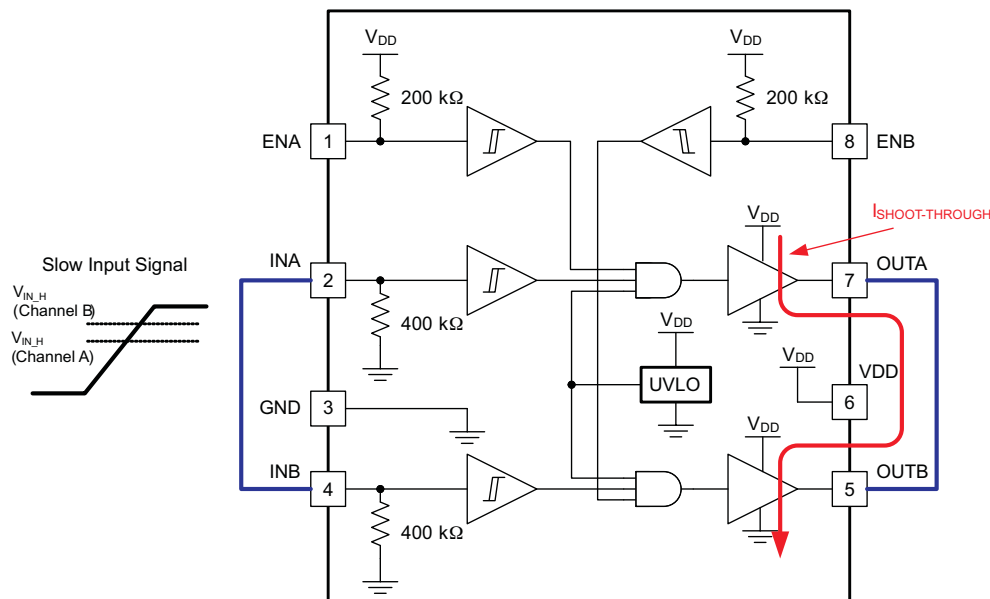

Figure 21. Slow Input Signal Can Cause Shoot-Through Between Channels During Paralleling (Recommended DV/DT is 20 V/Ms or Higher)

Feature Description (continued)

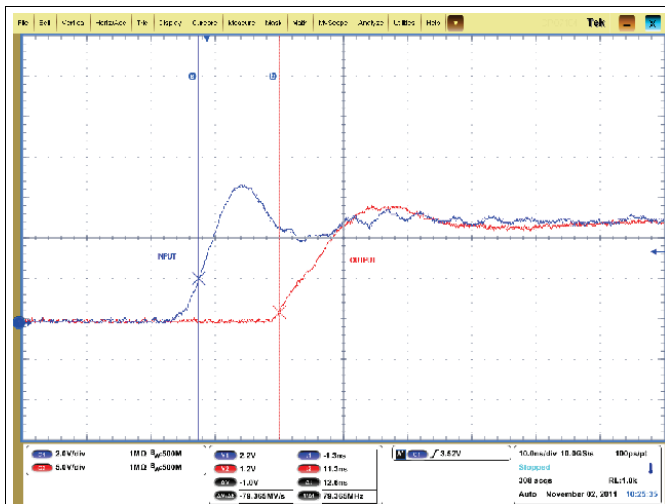

Figure 22. Turnon Propagation Delay
($C_L = 1.8 \text{ nF}$, $V_{DD} = 12 \text{ V}$)

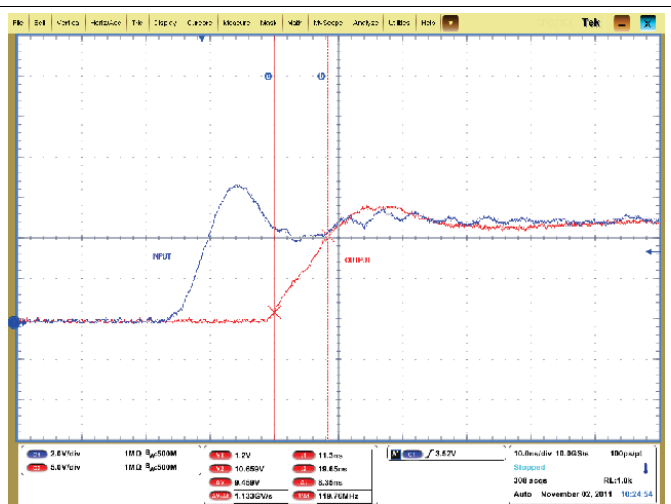

Figure 23. Turnon Rise Time
($C_L = 1.8 \text{ nF}$, $V_{DD} = 12 \text{ V}$)

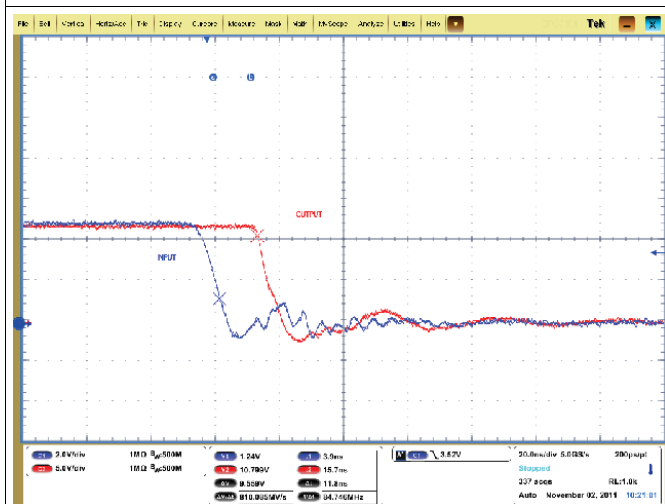

Figure 24. Turnoff Propagation Delay
($C_L = 1.8 \text{ nF}$, $V_{DD} = 12 \text{ V}$)

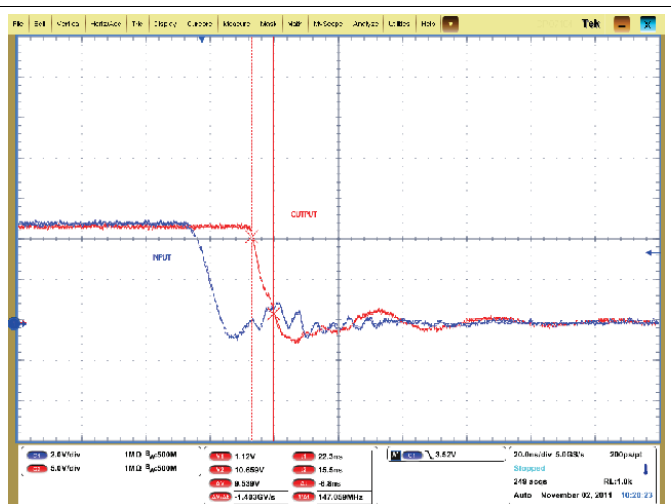

Figure 25. Turnoff Fall Time
($C_L = 1.8 \text{ nF}$, $V_{DD} = 12 \text{ V}$)

8.4 Device Functional Modes

Table 2. Device Logic Table

| ENA | ENB | INA | INB | UCC27524A-Q1 | |
|------------------|------------------|------------------|------------------|--------------|------|
| | | | | OUTA | OUTB |
| H | H | L | L | L | L |
| H | H | L | H | L | H |
| H | H | H | L | H | L |
| H | H | H | H | H | H |
| L | L | Any | Any | L | L |
| Any | Any | x ⁽¹⁾ | x ⁽¹⁾ | L | L |
| x ⁽¹⁾ | x ⁽¹⁾ | L | L | L | L |
| x ⁽¹⁾ | x ⁽¹⁾ | L | H | L | H |
| x ⁽¹⁾ | x ⁽¹⁾ | H | L | H | L |
| x ⁽¹⁾ | x ⁽¹⁾ | H | H | H | H |

(1) Floating condition.

9 Application and Implementation

NOTE

Information in the following applications sections is not part of the TI component specification, and TI does not warrant its accuracy or completeness. TI's customers are responsible for determining suitability of components for their purposes. Customers should validate and test their design implementation to confirm system functionality.

9.1 Application Information

High-current gate-driver devices are required in switching power applications for a variety of reasons. In order to effect the fast switching of power devices and reduce associated switching-power losses, a powerful gate-driver device employs between the PWM output of control devices and the gates of the power semiconductor devices. Further, gate-driver devices are indispensable when it is not feasible for the PWM controller device to directly drive the gates of the switching devices. With the advent of digital power, this situation is often encountered because the PWM signal from the digital controller is often a 3.3-V logic signal which is not capable of effectively turning on a power switch. A level-shifting circuitry is required to boost the 3.3-V signal to the gate-drive voltage (such as 12 V) in order to fully turn on the power device and minimize conduction losses. Traditional buffer-drive circuits based on NPN/PNP bipolar transistors in a totem-pole arrangement, as emitter-follower configurations, prove inadequate with digital power because the traditional buffer-drive circuits lack level-shifting capability. Gate-driver devices effectively combine both the level-shifting and buffer-drive functions. Gate-driver devices also find other needs such as minimizing the effect of high-frequency switching noise by locating the high-current driver physically close to the power switch, driving gate-drive transformers and controlling floating power-device gates, reducing power dissipation and thermal stress in controller devices by moving gate-charge power losses into the controller. Finally, emerging wide band-gap power-device technologies such as GaN based switches, which are capable of supporting very high switching frequency operation, are driving special requirements in terms of gate-drive capability. These requirements include operation at low VDD voltages (5 V or lower), low propagation delays, tight delay matching and availability in compact, low-inductance packages with good thermal capability. In summary, gate-driver devices are an extremely important component in switching power combining benefits of high-performance, low-cost, component-count, board-space reduction, and simplified system design.

9.2 Typical Application

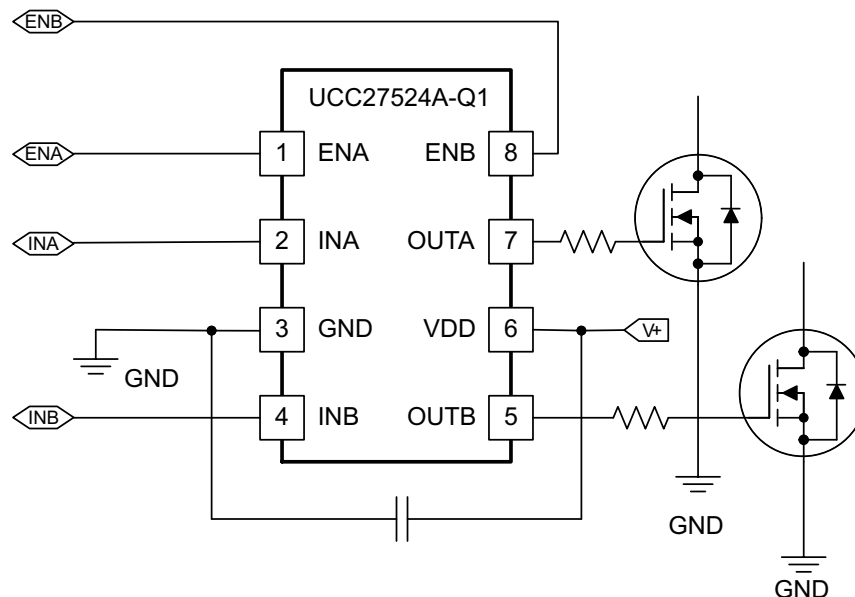

Figure 26. UCC27524A-Q1 Typical Application Diagram

Typical Application (continued)

9.2.1 Design Requirements

When selecting the proper gate driver device for an end application, some desiring considerations must be evaluated first in order to make the most appropriate selection. Among these considerations are V_{DD}, UVLO, Drive current and power dissipation.

9.2.2 Detailed Design Procedure

9.2.2.1 V_{DD} and Undervoltage Lockout

The UCC27524A-Q1 device has an internal undervoltage-lockout (UVLO) protection feature on the V_{DD} pin supply circuit blocks. When V_{DD} is rising and the level is still below UVLO threshold, this circuit holds the output low, regardless of the status of the inputs. The UVLO is typically 4.25 V with 350-mV typical hysteresis. This hysteresis prevents chatter when low V_{DD} supply voltages have noise from the power supply and also when there are droops in the V_{DD} bias voltage when the system commences switching and there is a sudden increase in I_{DD}. The capability to operate at low voltage levels such as below 5 V, along with best in class switching characteristics, is especially suited for driving emerging GaN power semiconductor devices.

For example, at power up, the UCC27524A-Q1 driver-device output remains low until the V_{DD} voltage reaches the UVLO threshold if enable pin is active or floating. The magnitude of the OUT signal rises with V_{DD} until steady-state V_{DD} is reached. The operation in Figure 27 shows that the output remains low until the UVLO threshold is reached, and then the output is in-phase with the input.

Because the device draws current from the V_{DD} pin to bias all internal circuits, for the best high-speed circuit performance, two V_{DD} bypass capacitors are recommended to prevent noise problems. The use of surface mount components is highly recommended. A 0.1-μF ceramic capacitor must be located as close as possible to the V_{DD} to GND pins of the gate-driver device. In addition, a larger capacitor (such as 1-μF) with relatively low ESR must be connected in parallel and close proximity, in order to help deliver the high-current peaks required by the load. The parallel combination of capacitors presents a low impedance characteristic for the expected current levels and switching frequencies in the application.

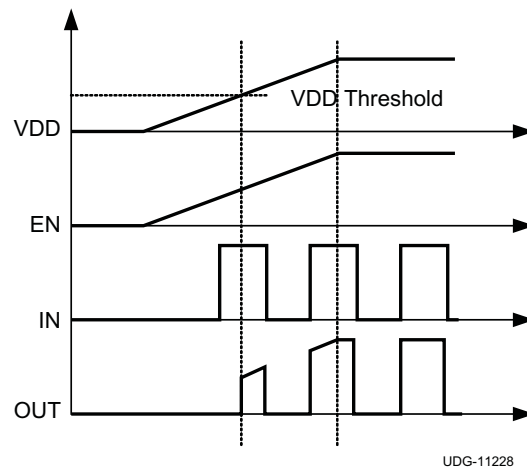

Figure 27. Power-Up Non-Inverting Driver

9.2.2.2 Drive Current and Power Dissipation

The UCC27524A-Q1 driver is capable of delivering 5-A of current to a MOSFET gate for a period of several-hundred nanoseconds at V_{DD} = 12 V. High peak current is required to turn the device ON quickly. Then, to turn the device OFF, the driver is required to sink a similar amount of current to ground which repeats at the operating frequency of the power device. The power dissipated in the gate driver device package depends on the following factors:

- Gate charge required of the power MOSFET (usually a function of the drive voltage V_{GS}, which is very close to input bias supply voltage V_{DD} due to low V_{OH} drop-out)
- Switching frequency

Typical Application (continued)

- Use of external gate resistors

Because UCC27524A-Q1 features very low quiescent currents and internal logic to eliminate any shoot-through in the output driver stage, their effect on the power dissipation within the gate driver can be safely assumed to be negligible.

When a driver device is tested with a discrete, capacitive load calculating the power that is required from the bias supply is fairly simple. The energy that must be transferred from the bias supply to charge the capacitor is given by [Equation 1](#).

$$E_G = \frac{1}{2} C_{LOAD} V_{DD}^2$$

where

- C_{LOAD} is the load capacitor
- V_{DD}^2 is the bias voltage feeding the driver

(1)

Typical Application (continued)

There is an equal amount of energy dissipated when the capacitor is charged. This leads to a total power loss given by [Equation 2](#).

$$P_G = C_{LOAD} V_{DD}^2 f_{SW}$$

where

- f_{SW} is the switching frequency (2)

With $V_{DD} = 12\text{ V}$, $C_{LOAD} = 10\text{ nF}$ and $f_{SW} = 300\text{ kHz}$ the power loss is calculated with [Equation 3](#).

$$P_G = 10\text{ nF} \times 12\text{ V}^2 \times 300\text{ kHz} = 0.432\text{ W} \quad (3)$$

The switching load presented by a power MOSFET is converted to an equivalent capacitance by examining the gate charge required to switch the device. This gate charge includes the effects of the input capacitance plus the added charge needed to swing the drain voltage of the power device as it switches between the ON and OFF states. Most manufacturers provide specifications that provide the typical and maximum gate charge, in nC, to switch the device under specified conditions. Using the gate charge Q_g , the power that must be dissipated when charging a capacitor is determined which by using the equivalence $Q_g = C_{LOAD} V_{DD}$ to provide [Equation 4](#) for power:

$$P_G = C_{LOAD} V_{DD}^2 f_{SW} = Q_g V_{DD} f_{SW} \quad (4)$$

Assuming that the UCC27524A-Q1 device is driving power MOSFET with 60 nC of gate charge ($Q_g = 60\text{ nC}$ at $V_{DD} = 12\text{ V}$) on each output, the gate charge related power loss is calculated with [Equation 5](#).

$$P_G = 2 \times 60\text{ nC} \times 12\text{ V} \times 300\text{ kHz} = 0.432\text{ W} \quad (5)$$

This power P_G is dissipated in the resistive elements of the circuit when the MOSFET turns on or turns off. Half of the total power is dissipated when the load capacitor is charged during turnon, and the other half is dissipated when the load capacitor is discharged during turnoff. When no external gate resistor is employed between the driver and MOSFET/IGBT, this power is completely dissipated inside the driver package. With the use of external gate drive resistors, the power dissipation is shared between the internal resistance of driver and external gate resistor in accordance to the ratio of the resistances (more power dissipated in the higher resistance component). Based on this simplified analysis, the driver power dissipation during switching is calculated as follows (see [Equation 6](#)):

$$P_{SW} = 0.5 \times Q_G \times V_{DD} \times f_{SW} \times \left(\frac{R_{OFF}}{R_{OFF} + R_{GATE}} + \frac{R_{ON}}{R_{ON} + R_{GATE}} \right)$$

where

- $R_{OFF} = R_{OL}$
- R_{ON} (effective resistance of pullup structure) = $1.5 \times R_{OL}$ (6)

In addition to the above gate-charge related power dissipation, additional dissipation in the driver is related to the power associated with the quiescent bias current consumed by the device to bias all internal circuits such as input stage (with pullup and pulldown resistors), enable, and UVLO sections. As shown in [Figure 4](#), the quiescent current is less than 0.6 mA even in the highest case. The quiescent power dissipation is calculated easily with [Equation 7](#).

$$P_Q = I_{DD} V_{DD} \quad (7)$$

Assuming , $I_{DD} = 6\text{ mA}$, the power loss is:

$$P_Q = 0.6\text{ mA} \times 12\text{ V} = 7.2\text{ mW} \quad (8)$$

Clearly, this power loss is insignificant compared to gate charge related power dissipation calculated earlier.

With a 12-V supply, the bias current is estimated as follows, with an additional 0.6-mA overhead for the quiescent consumption:

$$I_{DD} \sim \frac{P_G}{V_{DD}} = \frac{0.432\text{ W}}{12\text{ V}} = 0.036\text{ A} \quad (9)$$

Typical Application (continued)

9.2.3 Application Curves

Figure 28 and Figure 29 show the typical switching characteristics of the UCC27524A-Q1 device.

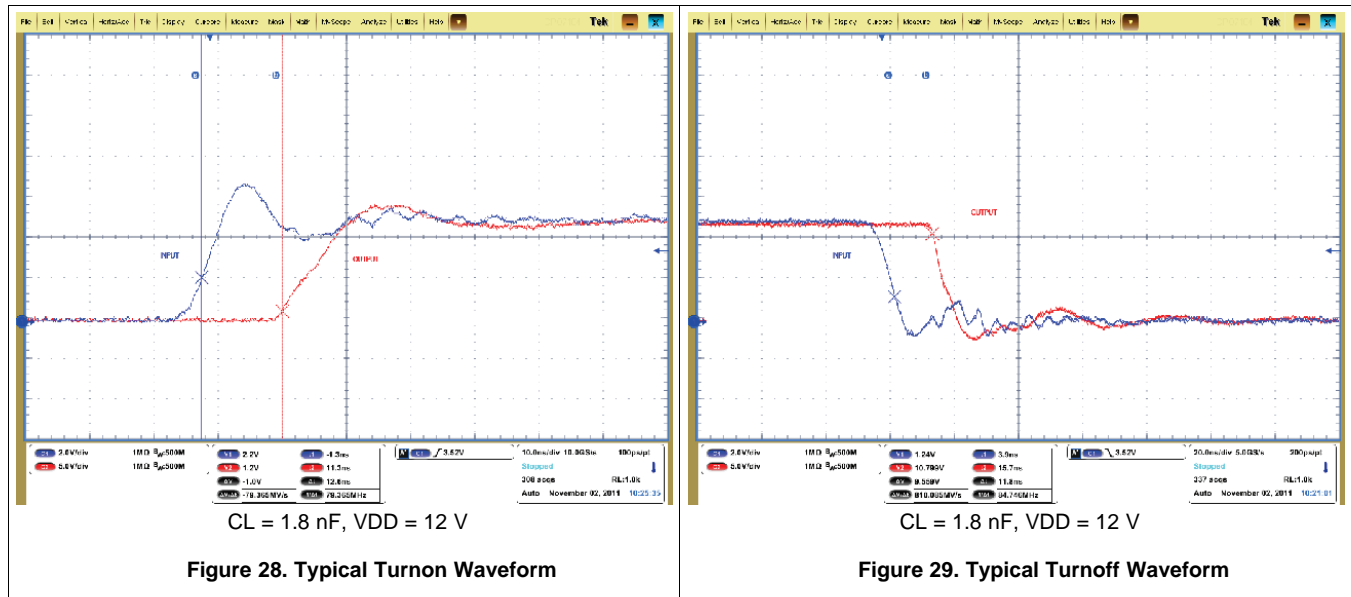

10 Power Supply Recommendations

The bias supply voltage range for which the UCC27524A-Q1 device is rated to operate is from 4.5 V to 18 V. The lower end of this range is governed by the internal undervoltage-lockout (UVLO) protection feature on the V_{DD} pin supply circuit blocks. Whenever the driver is in UVLO condition when the V_{DD} pin voltage is below the V_{ON} supply start threshold, this feature holds the output low, regardless of the status of the inputs. The upper end of this range is driven by the 20-V absolute maximum voltage rating of the V_{DD} pin of the device (which is a stress rating). Keeping a 2-V margin to allow for transient voltage spikes, the maximum recommended voltage for the V_{DD} pin is 18 V.

The UVLO protection feature also involves a hysteresis function. This means that when the V_{DD} pin bias voltage has exceeded the threshold voltage and device begins to operate, and if the voltage drops, then the device continues to deliver normal functionality unless the voltage drop exceeds the hysteresis specification VDD_H. Therefore, ensuring that, while operating at or near the 4.5-V range, the voltage ripple on the auxiliary power supply output is smaller than the hysteresis specification of the device is important to avoid triggering device shutdown. During system shutdown, the device operation continues until the V_{DD} pin voltage has dropped below the V_{OFF} threshold which must be accounted for while evaluating system shutdown timing design requirements. Likewise, at system startup, the device does not begin operation until the V_{DD} pin voltage has exceeded above the V_{ON} threshold.

The quiescent current consumed by the internal circuit blocks of the device is supplied through the V_{DD} pin. Although this fact is well known, recognizing that the charge for source current pulses delivered by the OUTA/B pin is also supplied through the same V_{DD} pin is important. As a result, every time a current is sourced out of the output pins, a corresponding current pulse is delivered into the device through the V_{DD} pin. Thus ensuring that local bypass capacitors are provided between the V_{DD} and GND pins and located as close to the device as possible for the purpose of decoupling is important. A low ESR, ceramic surface mount capacitor is a must. TI recommends having 2 capacitors; a 100-nF ceramic surface-mount capacitor which can be nudged very close to the pins of the device and another surface-mount capacitor of few microfarads added in parallel.

11 Layout

11.1 Layout Guidelines

Proper PCB layout is extremely important in a high-current fast-switching circuit to provide appropriate device operation and design robustness. The UCC27524A-Q1 gate driver incorporates short propagation delays and powerful output stages capable of delivering large current peaks with very fast rise and fall times at the gate of power MOSFET to facilitate voltage transitions very quickly. At higher V_{DD} voltages, the peak current capability is even higher (5-A peak current is at $V_{DD} = 12\text{ V}$). Very high di/dt causes unacceptable ringing if the trace lengths and impedances are not well controlled. The following circuit layout guidelines are strongly recommended when designing with these high-speed drivers.

- Locate the driver device as close as possible to power device in order to minimize the length of high-current traces between the output pins and the gate of the power device.
- Locate the V_{DD} bypass capacitors between V_{DD} and GND as close as possible to the driver with minimal trace length to improve the noise filtering. These capacitors support high peak current being drawn from V_{DD} during turnon of power MOSFET. The use of low inductance surface-mounted-device (SMD) components such as chip resistors and chip capacitors is highly recommended.
- The turnon and turnoff current loop paths (driver device, power MOSFET and V_{DD} bypass capacitor) must be minimized as much as possible in order to keep the stray inductance to a minimum. High di/dt is established in these loops at two instances during turnon and turnoff transients which induces significant voltage transients on the output pin of the driver device and Gate of the power MOSFET.
- Wherever possible, parallel the source and return traces to take advantage of flux cancellation
- Separate power traces and signal traces, such as output and input signals.
- Star-point grounding is a good way to minimize noise coupling from one current loop to another. The GND of the driver is connected to the other circuit nodes such as source of power MOSFET and ground of PWM controller at one, single point. The connected paths must be as short as possible to reduce inductance and be as wide as possible to reduce resistance.
- Use a ground plane to provide noise shielding. Fast rise and fall times at OUT may corrupt the input signals during transition. The ground plane must not be a conduction path for any current loop. Instead the ground plane must be connected to the star-point with one single trace to establish the ground potential. In addition to noise shielding, the ground plane can help in power dissipation as well
- Exercise caution when replacing the UCC2732x/UCC2742x devices with the UCC27524A-Q1 device:
 - The UCC27524A-Q1 device is a much stronger gate driver (5-A peak current versus 4-A peak current).
 - The UCC27524A-Q1 device is a much faster gate driver (13-ns/13-ns rise and fall propagation delay versus 25-ns/35-ns rise and fall propagation delay).

11.2 Layout Example

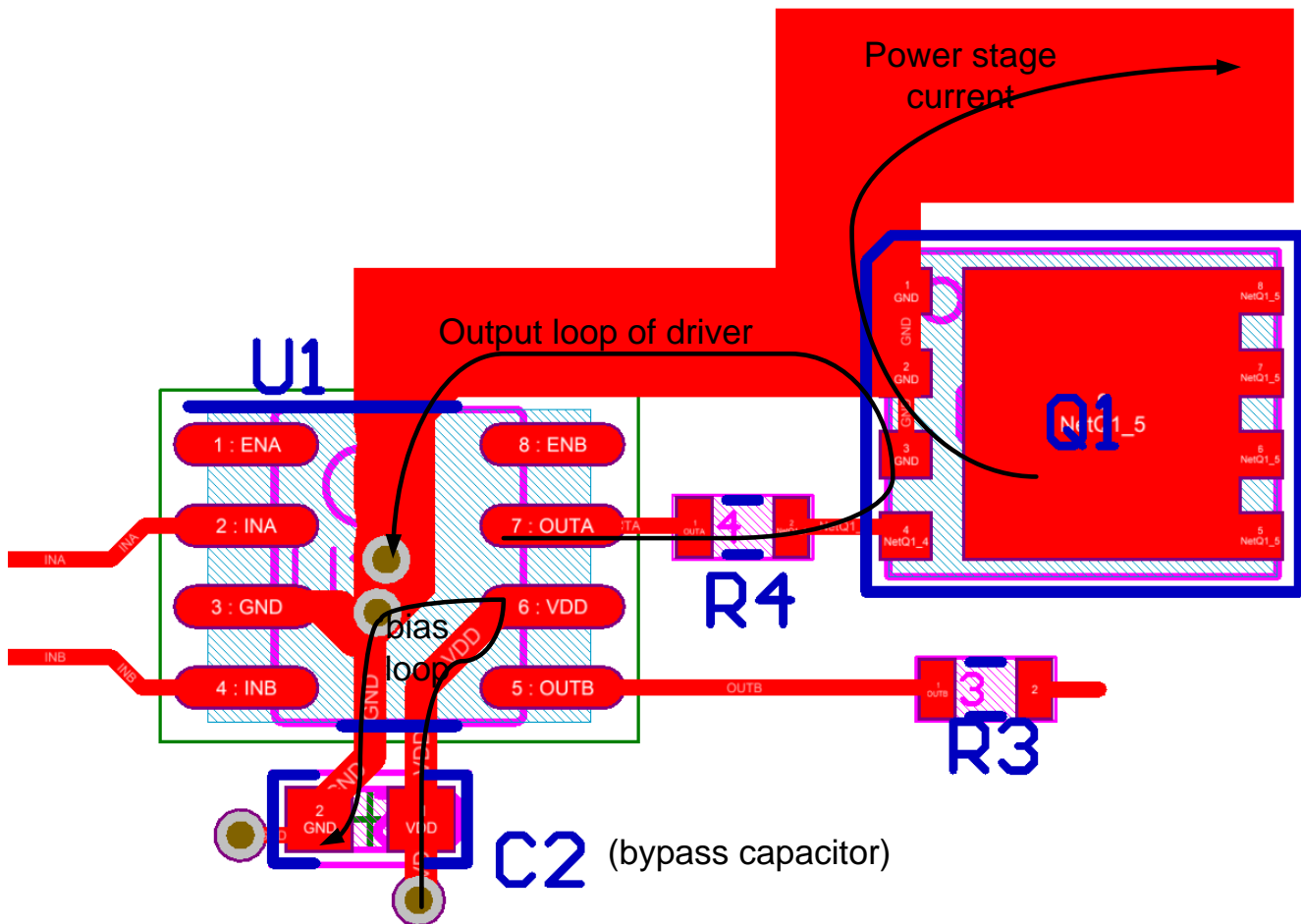

Figure 30. UCC27524A-Q1 Layout Example

11.3 Thermal Considerations

The useful range of a driver is greatly affected by the drive power requirements of the load and the thermal characteristics of the device package. In order for a gate driver device to be useful over a particular temperature range the package must allow for the efficient removal of the heat produced while keeping the junction temperature within rated limits. For detailed information regarding the thermal information table, please refer to Application Note from Texas Instruments entitled, *Semiconductor and IC Package Thermal Metrics* (SPRA953).

Among the different package options available for the UCC27524A-Q1 device, power dissipation capability of the DGN package is of particular mention. The HVSSOP-8 (DGN) package offers a means of removing the heat from the semiconductor junction through the bottom of the package. This package offers an exposed thermal pad at the base of the package. This pad is soldered to the copper on the printed circuit board directly underneath the device package, reducing the thermal resistance to a very low value. This allows a significant improvement in heat-sinking over that available in the D package. The printed circuit board must be designed with thermal lands and thermal vias to complete the heat removal subsystem. Note that the exposed pads in the HVSSOP-8 package are not directly connected to any leads of the package, however, the PowerPAD is electrically and thermally connected to the substrate of the device which is the ground of the device. TI recommends to externally connect the exposed pads to GND in PCB layout for better EMI immunity.

12 Device and Documentation Support

12.1 Community Resources

The following links connect to TI community resources. Linked contents are provided "AS IS" by the respective contributors. They do not constitute TI specifications and do not necessarily reflect TI's views; see TI's [Terms of Use](#).

TI E2E™ Online Community *TI's Engineer-to-Engineer (E2E) Community*. Created to foster collaboration among engineers. At e2e.ti.com, you can ask questions, share knowledge, explore ideas and help solve problems with fellow engineers.

Design Support *TI's Design Support* Quickly find helpful E2E forums along with design support tools and contact information for technical support.

12.2 Trademarks

PowerPad, E2E are trademarks of Texas Instruments.
All other trademarks are the property of their respective owners.

12.3 Electrostatic Discharge Caution



These devices have limited built-in ESD protection. The leads should be shorted together or the device placed in conductive foam during storage or handling to prevent electrostatic damage to the MOS gates.

12.4 Glossary

[SLYZ022](#) — *TI Glossary*.

This glossary lists and explains terms, acronyms, and definitions.

13 Mechanical, Packaging, and Orderable Information

The following pages include mechanical, packaging, and orderable information. This information is the most current data available for the designated devices. This data is subject to change without notice and revision of this document. For browser-based versions of this data sheet, refer to the left-hand navigation.

PACKAGING INFORMATION

| Orderable Device | Status (1) | Package Type | Package Drawing | Pins | Package Qty | Eco Plan (2) | Lead/Ball Finish (6) | MSL Peak Temp (3) | Op Temp (°C) | Device Marking (4/5) | Samples |
|------------------|---------------|-------------------|-----------------|------|-------------|----------------------------|-------------------------|----------------------|--------------|-------------------------|---------|
| UCC27524AQDGNRQ1 | NRND | MSOP- PowerPAD | DGN | 8 | 2500 | Green (RoHS & no Sb/Br) | CU NIPDAUAG | Level-2-260C-1 YEAR | -40 to 140 | 7524Q | |
| UCC27524AQDRQ1 | ACTIVE | SOIC | D | 8 | 3000 | Green (RoHS & no Sb/Br) | CU NIPDAU | Level-1-260C-UNLIM | -40 to 140 | 524AQ | Samples |

(1) The marketing status values are defined as follows:

ACTIVE: Product device recommended for new designs.

LIFEBUY: TI has announced that the device will be discontinued, and a lifetime-buy period is in effect.

NRND: Not recommended for new designs. Device is in production to support existing customers, but TI does not recommend using this part in a new design.

PREVIEW: Device has been announced but is not in production. Samples may or may not be available.

OBSELETE: TI has discontinued the production of the device.

(2) **RoHS:** TI defines "RoHS" to mean semiconductor products that are compliant with the current EU RoHS requirements for all 10 RoHS substances, including the requirement that RoHS substance do not exceed 0.1% by weight in homogeneous materials. Where designed to be soldered at high temperatures, "RoHS" products are suitable for use in specified lead-free processes. TI may reference these types of products as "Pb-Free".

RoHS Exempt: TI defines "RoHS Exempt" to mean products that contain lead but are compliant with EU RoHS pursuant to a specific EU RoHS exemption.

Green: TI defines "Green" to mean the content of Chlorine (Cl) and Bromine (Br) based flame retardants meet JS709B low halogen requirements of <=1000ppm threshold. Antimony trioxide based flame retardants must also meet the <=1000ppm threshold requirement.

(3) MSL, Peak Temp. - The Moisture Sensitivity Level rating according to the JEDEC industry standard classifications, and peak solder temperature.

(4) There may be additional marking, which relates to the logo, the lot trace code information, or the environmental category on the device.

(5) Multiple Device Markings will be inside parentheses. Only one Device Marking contained in parentheses and separated by a "~" will appear on a device. If a line is indented then it is a continuation of the previous line and the two combined represent the entire Device Marking for that device.

(6) Lead/Ball Finish - Orderable Devices may have multiple material finish options. Finish options are separated by a vertical ruled line. Lead/Ball Finish values may wrap to two lines if the finish value exceeds the maximum column width.

Important Information and Disclaimer:The information provided on this page represents TI's knowledge and belief as of the date that it is provided. TI bases its knowledge and belief on information provided by third parties, and makes no representation or warranty as to the accuracy of such information. Efforts are underway to better integrate information from third parties. TI has taken and continues to take reasonable steps to provide representative and accurate information but may not have conducted destructive testing or chemical analysis on incoming materials and chemicals. TI and TI suppliers consider certain information to be proprietary, and thus CAS numbers and other limited information may not be available for release.

In no event shall TI's liability arising out of such information exceed the total purchase price of the TI part(s) at issue in this document sold by TI to Customer on an annual basis.

OTHER QUALIFIED VERSIONS OF UCC27524A-Q1 :

- Catalog: [UCC27524A](#)

NOTE: Qualified Version Definitions:

- Catalog - TI's standard catalog product

TAPE AND REEL INFORMATION

QUADRANT ASSIGNMENTS FOR PIN 1 ORIENTATION IN TAPE

*All dimensions are nominal

| Device | Package Type | Package Drawing | Pins | SPQ | Reel Diameter (mm) | Reel Width W1 (mm) | A0 (mm) | B0 (mm) | K0 (mm) | P1 (mm) | W (mm) | Pin1 Quadrant |
|------------------|----------------|-----------------|------|------|--------------------|--------------------|---------|---------|---------|---------|--------|---------------|
| UCC27524AQDGNRQ1 | MSOP-Power PAD | DGN | 8 | 2500 | 330.0 | 12.4 | 5.3 | 3.4 | 1.4 | 8.0 | 12.0 | Q1 |
| UCC27524AQDRQ1 | SOIC | D | 8 | 3000 | 330.0 | 12.4 | 6.4 | 5.2 | 2.1 | 8.0 | 12.0 | Q1 |

TAPE AND REEL BOX DIMENSIONS



*All dimensions are nominal

| Device | Package Type | Package Drawing | Pins | SPQ | Length (mm) | Width (mm) | Height (mm) |
|------------------|---------------|-----------------|------|------|-------------|------------|-------------|
| UCC27524AQDGNRQ1 | MSOP-PowerPAD | DGN | 8 | 2500 | 366.0 | 364.0 | 50.0 |
| UCC27524AQDRQ1 | SOIC | D | 8 | 3000 | 367.0 | 367.0 | 35.0 |



D0008A

PACKAGE OUTLINE

SOIC - 1.75 mm max height

SMALL OUTLINE INTEGRATED CIRCUIT



4214825/C 02/2019

NOTES:

- Linear dimensions are in inches [millimeters]. Dimensions in parenthesis are for reference only. Controlling dimensions are in inches. Dimensioning and tolerancing per ASME Y14.5M.
- This drawing is subject to change without notice.
- This dimension does not include mold flash, protrusions, or gate burrs. Mold flash, protrusions, or gate burrs shall not exceed $.006$ [0.15] per side.
- This dimension does not include interlead flash.
- Reference JEDEC registration MS-012, variation AA.

EXAMPLE BOARD LAYOUT

D0008A

SOIC - 1.75 mm max height

SMALL OUTLINE INTEGRATED CIRCUIT



LAND PATTERN EXAMPLE
 EXPOSED METAL SHOWN
 SCALE:8X



SOLDER MASK DETAILS

4214825/C 02/2019

NOTES: (continued)

- 6. Publication IPC-7351 may have alternate designs.
- 7. Solder mask tolerances between and around signal pads can vary based on board fabrication site.

EXAMPLE STENCIL DESIGN

D0008A

SOIC - 1.75 mm max height

SMALL OUTLINE INTEGRATED CIRCUIT



SOLDER PASTE EXAMPLE
BASED ON .005 INCH [0.125 MM] THICK STENCIL
SCALE:8X

4214825/C 02/2019

NOTES: (continued)

8. Laser cutting apertures with trapezoidal walls and rounded corners may offer better paste release. IPC-7525 may have alternate design recommendations.
9. Board assembly site may have different recommendations for stencil design.

DGN (S-PDSO-G8)

PowerPAD™ PLASTIC SMALL OUTLINE

THERMAL INFORMATION

This PowerPAD™ package incorporates an exposed thermal pad that is designed to be attached to a printed circuit board (PCB). The thermal pad must be soldered directly to the PCB. After soldering, the PCB can be used as a heatsink. In addition, through the use of thermal vias, the thermal pad can be attached directly to the appropriate copper plane shown in the electrical schematic for the device, or alternatively, can be attached to a special heatsink structure designed into the PCB. This design optimizes the heat transfer from the integrated circuit (IC).

For additional information on the PowerPAD package and how to take advantage of its heat dissipating abilities, refer to Technical Brief, PowerPAD Thermally Enhanced Package, Texas Instruments Literature No. SLMA002 and Application Brief, PowerPAD Made Easy, Texas Instruments Literature No. SLMA004. Both documents are available at www.ti.com.

The exposed thermal pad dimensions for this package are shown in the following illustration.

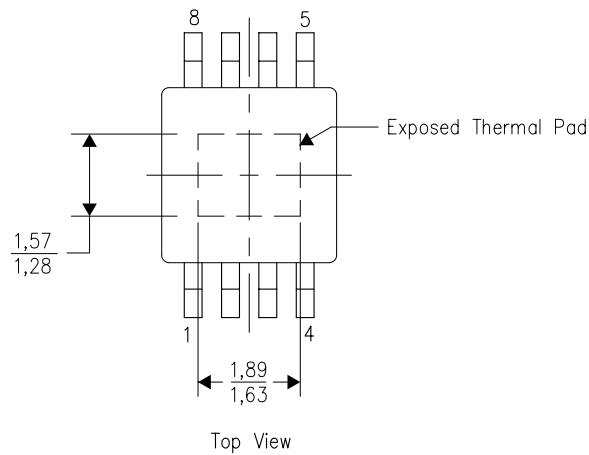

Exposed Thermal Pad Dimensions

4206323-2/1 12/11

NOTE: All linear dimensions are in millimeters

PowerPAD is a trademark of Texas Instruments



- NOTES:
- A. All linear dimensions are in millimeters.
 - B. This drawing is subject to change without notice.
 - C. Customers should place a note on the circuit board fabrication drawing not to alter the center solder mask defined pad.
 - D. This package is designed to be soldered to a thermal pad on the board. Refer to Technical Brief, PowerPad Thermally Enhanced Package, Texas Instruments Literature No. SLMA002, SLMA004, and also the Product Data Sheets for specific thermal information, via requirements, and recommended board layout. These documents are available at www.ti.com <<http://www.ti.com>>.
 - E. Laser cutting apertures with trapezoidal walls and also rounding corners will offer better paste release. Customers should contact their board assembly site for stencil design recommendations. Example stencil design based on a 50% volumetric metal load solder paste. Refer to IPC-7525 for other stencil recommendations.
 - F. Customers should contact their board fabrication site for solder mask tolerances between and around signal pads.

PowerPAD is a trademark of Texas Instruments

IMPORTANT NOTICE AND DISCLAIMER

TI PROVIDES TECHNICAL AND RELIABILITY DATA (INCLUDING DATASHEETS), DESIGN RESOURCES (INCLUDING REFERENCE DESIGNS), APPLICATION OR OTHER DESIGN ADVICE, WEB TOOLS, SAFETY INFORMATION, AND OTHER RESOURCES "AS IS" AND WITH ALL FAULTS, AND DISCLAIMS ALL WARRANTIES, EXPRESS AND IMPLIED, INCLUDING WITHOUT LIMITATION ANY IMPLIED WARRANTIES OF MERCHANTABILITY, FITNESS FOR A PARTICULAR PURPOSE OR NON-INFRINGEMENT OF THIRD PARTY INTELLECTUAL PROPERTY RIGHTS.

These resources are intended for skilled developers designing with TI products. You are solely responsible for (1) selecting the appropriate TI products for your application, (2) designing, validating and testing your application, and (3) ensuring your application meets applicable standards, and any other safety, security, or other requirements. These resources are subject to change without notice. TI grants you permission to use these resources only for development of an application that uses the TI products described in the resource. Other reproduction and display of these resources is prohibited. No license is granted to any other TI intellectual property right or to any third party intellectual property right. TI disclaims responsibility for, and you will fully indemnify TI and its representatives against, any claims, damages, costs, losses, and liabilities arising out of your use of these resources.

TI's products are provided subject to TI's Terms of Sale (www.ti.com/legal/termsofsale.html) or other applicable terms available either on ti.com or provided in conjunction with such TI products. TI's provision of these resources does not expand or otherwise alter TI's applicable warranties or warranty disclaimers for TI products.

Mailing Address: Texas Instruments, Post Office Box 655303, Dallas, Texas 75265
Copyright © 2019, Texas Instruments Incorporated

Looking for pricing, stock, or lifecycle information?

Click below to explore more details on WIN SOURCE:

 [View UCC27524AQDGNRQ1 on WIN SOURCE](#)

 [Texas Instruments](#) Information

Optimize Your Supply Chain with WIN SOURCE Solutions

-  Global Sourcing Solution
-  Obsolete Management
-  Cost Control Management
-  Shortage Management
-  Alternative Solution
-  Excess Inventory Management