



**THE DATASHEET OF  
HC55142IMZ**



## Low Power UniSLIC14 Family

The UniSLIC14 is a family of Ultra Low Power SLICs. The feature set and common pinouts of the UniSLIC14 family positions it as a universal solution for: Plain Old Telephone Service (POTS), PBX, Central Office, Loop Carrier, Fiber in the Loop, ISDN-TA and NT1+, Pairgain and Wireless Local Loop.

The UniSLIC14 family achieves its ultra low power operation through: Its automatic single and dual battery selection (based on line length) and battery tracking anti clipping to ensure the maximum loop coverage on the lowest battery voltage. This architecture is ideal for power critical applications such as ISDN NT1+, Pairgain and Wireless local loop products.

The UniSLIC14 family has many user programmable features. This family of SLICs delivers a low noise, low component count solution for Central Office and Loop Carrier universal voice grade designs. The product family integrates advanced pulse metering, test and signaling capabilities, and zero crossing ring control.

The UniSLIC14 family is designed in the Intersil "Latch" free Bonded Wafer process. This process dielectrically isolates the active circuitry to eliminate any leakage paths as found in our competition's J1 process. This makes the UniSLIC14 family compliant with "hot plug" requirements and operation in harsh outdoor environments.

## Block Diagram

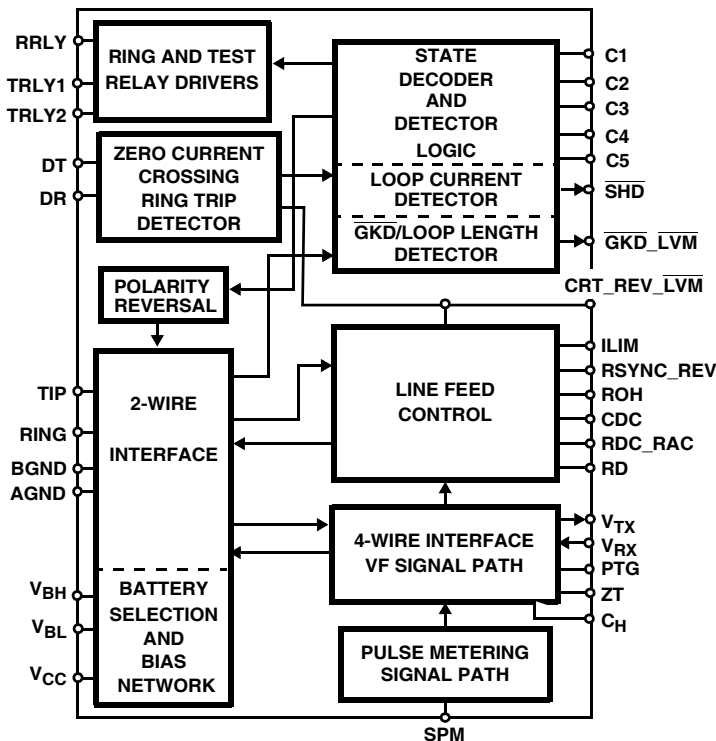

## Features

- Ultra Low Active Power (OHT) < 60mW
- Single/Dual Battery Operation
- Automatic Silent Battery Selection
- Power Management/Shutdown
- Battery Tracking Anti Clipping
- Single 5V Supply with 3V Compatible Logic
- Zero Crossing Ring Control
  - Zero Voltage On/Zero Current Off
- Tip/Ring Disconnect
- Pulse Metering Capability
- 4 Wire Loopback
- Programmable Current Feed
- Programmable Resistive Feed
- Programmable Loop Detect Threshold
- Programmable On-Hook and Off-Hook Overheads
- Programmable Overhead for Pulse Metering
- Programmable Polarity Reversal Time
- Selectable Transmit Gain 0dB/-6dB
- 2 Wire Impedance Set by Single Network
- Loop and Ground Key Detectors
- On-Hook Transmission
- Common Pinout
- Pb-Free Plus Anneal Available (RoHS Compliant)
- HC55121
  - Polarity Reversal
- HC55130
  - -63dB Longitudinal Balance
- HC55140
  - Polarity Reversal
  - Ground Start
  - Line Voltage Measurement
  - 2 Wire Loopback
  - -63dB Longitudinal Balance
- HC55142
  - Polarity Reversal
  - Ground Start
  - Line Voltage Measurement
  - 2.2V<sub>RMS</sub> Pulse Metering
  - 2 Wire Loopback
- HC55150
  - Polarity Reversal
  - Line Voltage Measurement
  - 2.2V<sub>RMS</sub> Pulse Metering
  - 2 Wire Loopback

## Related Literature

- AN9871, User's Guide for UniSLIC14 Eval Board
- AN9903, UniSLIC14 and TI TCM38C17

## Ordering Information

PART NUMBER*	MAX LOOP CURRENT (mA)	POLARITY REVERSAL	GND START	GND KEY	LINE VOLTAGE MEASUREMENT †	PULSE METERING	2 TEST RELAY DRIVERS	2 WIRE LOOP-BACK †	LONGITUDINAL BALANCE	TEMP RANGE (°C)	PKG. DWG. #
HC55120CB	30			•					53dB	0 to 70	M28.3 SOIC
HC55120CBZ Pb-free (Note)	30			•					53dB	0 to 70	M28.3 SOIC
HC55120CM	30			•					53dB	0 to 70	N28.45 PLCC
HC55120CMZ Pb-free (Note)	30			•					53dB	0 to 70	N28.45 PLCC
HC55121IB	30	•		•		•		•	53dB	-40 to 85	M28.3 SOIC
HC55121IBZ Pb-free (Note)	30	•		•		•		•	53dB	-40 to 85	M28.3 SOIC
HC55121IM	30	•		•		•		•	53dB	-40 to 85	N28.45 PLCC
HC55121IMZ Pb-free (Note)	30	•		•		•		•	53dB	-40 to 85	N28.45 PLCC
HC55130IB	45								63dB	-40 to 85	M28.3 SOIC
HC55130IB96 (Tape and Reel)	45								63dB	-40 to 85	M28.3 SOIC
HC55130IBZ Pb-free (Note)	45								63dB	-40 to 85	M28.3 SOIC
HC55130IBZ96 (Tape and Reel) Pb-free (Note)	45								63dB	-40 to 85	M28.3 SOIC
HC55130IM	45								63dB	-40 to 85	N28.45 PLCC
HC55130IMZ Pb-free (Note)	45								63dB	-40 to 85	N28.45 PLCC
HC55140IB	45	•	•	•	•			•	63dB	-40 to 85	M28.3 SOIC
HC55140IBZ Pb-free (Note)	45	•	•	•	•			•	63dB	-40 to 85	M28.3 SOIC
HC55140IM	45	•	•	•	•			•	63dB	-40 to 85	N28.45 PLCC
HC55140IMZ Pb-free (Note)	45	•	•	•	•			•	63dB	-40 to 85	N28.45 PLCC
HC55142IB	45	•	•	•	•	•		•	63dB	-40 to 85	M28.3 SOIC
HC55142IBZ Pb-free (Note)	45	•	•	•	•	•		•	63dB	-40 to 85	M28.3 SOIC
HC55142IM	45	•	•	•	•	•		•	63dB	-40 to 85	N28.45 PLCC
HC55142IM96 (Tape and Reel)	45	•	•	•	•	•		•	63dB	-40 to 85	N28.45 PLCC
HC55142IMZ Pb-free (Note)	45	•	•	•	•	•		•	63dB	-40 to 85	N28.45 PLCC
HC55142IMZ96 (Tape and Reel) Pb-free (Note)	45	•	•	•	•	•		•	63dB	-40 to 85	N28.45 PLCC

**Ordering Information** (Continued)

PART NUMBER*	MAX LOOP CURRENT (mA)	POLARITY REVERSAL	GND START	GND KEY	LINE VOLTAGE MEASUREMENT †	PULSE METERING	2 TEST RELAY DRIVERS	2 WIRE LOOP-BACK †	LONGITUDINAL BALANCE	TEMP RANGE (°C)	PKG. DWG. #
HC55143IM	45	•	•	•	•	•	•	•	63dB	-40 to 85	N32.45x55 PLCC
HC55143IMZ Pb-free (Note)	45	•	•	•	•	•	•	•	63dB	-40 to 85	N32.45x55 PLCC
HC55150CB	45	•			•	•		•	55dB	0 to 70	M28.3 SOIC
HC55150CBZ Pb-free (Note)	45	•			•	•		•	55dB	0 to 70	M28.3 SOIC
HC55150CM	45	•			•	•		•	55dB	0 to 70	N28.45 PLCC
HC55150CMZ Pb-free (Note)	45	•			•	•		•	55dB	0 to 70	N28.45 PLCC
HC5514XEVAL1	Evaluation board										

† Available by placing SLIC in Test mode.

\*Part marking is the same as the part number on all parts.

NOTE: Intersil Pb-free plus anneal products employ special Pb-free material sets; molding compounds/die attach materials and 100% matte tin plate termination finish, which are RoHS compliant and compatible with both SnPb and Pb-free soldering operations. Intersil Pb-free products are MSL classified at Pb-free peak reflow temperatures that meet or exceed the Pb-free requirements of IPC/JEDEC J STD-020.

**Device Operating Modes**

C3	C2	C1	DESCRIPTION	HC55120	HC55121	HC55130/1	HC55140/1	HC55142/3	HC55150/1
0	0	0	Open Circuit 4-Wire Loopback	•	•	•	•	•	•
0	0	1	Ringing	•	•	•	•	•	•
0	1	0	Forward Active	•	•	•	•	•	•
0	1	1	Test Forward Active 2 Wire Loopback and Line Voltage Measurement		•		•	•	•
1	0	0	Tip Open Ground Start				•	•	
1	0	1	Reserved	•	•	•	•	•	•
1	1	0	Reverse Active		•		•	•	•
1	1	1	Test Reverse Active Line Voltage Measurement				•	•	•

**Absolute Maximum Ratings**  $T_A = 25^\circ\text{C}$

Temperature, Humidity  
 Storage Temperature Range .....-65°C to 150°C  
 Operating Temperature Range.....-40°C to 110°C  
 Operating Junction Temperature Range .....-40°C to 150°C

Power Supply ( $-40^\circ\text{C} \leq T_A \leq 85^\circ\text{C}$ )  
 Supply Voltage  $V_{CC}$  to GND .....-0.4V to 7V  
 Supply Voltage  $V_{BL}$  to GND .....- $V_{BH}$  to 0.4V  
 Supply Voltage  $V_{BH}$  to GND, Continuous .....-75V to 0.4V  
 Supply Voltage  $V_{BH}$  to GND, 10ms .....-80V to 0.4V

Relay Driver  
 Ring Relay Supply Voltage .....0V to 14V  
 Ring Relay Current..... 50mA

Digital Inputs, Outputs (C1, C2, C3, C4, C5, SHD, GKD\_LVM)  
 Input Voltage ..... -0.4V to  $V_{CC}$   
 Output Voltage (SHD, GKD\_LVM Not Active) ..... -0.4V to  $V_{CC}$   
 Output Current (SHD, GKD\_LVM) ..... 5mA

ESD Rating .....500V  
 Gate Count..... 543 Transistors, 51 Diodes

Tipx and Ringx Terminals ( $-40^\circ\text{C} \leq T_A \leq 85^\circ\text{C}$ )  
 Tipx or Ringx Current ..... -100mA to 100mA

**Thermal Information**

Thermal Resistance (Typical, Note 1)	$\theta_{JA}$
28 Lead PLCC Package.....	52°C/W
28 Lead SOIC Package.....	45°C/W
32 Lead PLCC Package.....	66.2°C/W
Continuous Power Dissipation at 85°C	
28 Lead PLCC Package.....	1.5W
28 Lead SOIC Package.....	2.0W
32 Lead PLCC Package.....	1.4W
Lead Temperature (Soldering 10s).....	300°C
(PLCC, SOIC - Lead Tips Only)	Derate above 70°C

**Tip and Ring Terminals**

Tipx or Ringx, Current, Pulse < 10ms, $T_{REP} > 10s$ .....	.2A
Tipx or Ringx, Current, Pulse < 1ms, $T_{REP} > 10s$ .....	.5A
Tipx or Ringx, Current, Pulse < 10µs, $T_{REP} > 10s$ .....	15A
Tipx or Ringx, Current, Pulse < 1µs, $T_{REP} > 10s$ .....	.20A
Tipx or Ringx, Pulse < 250ns, $T_{REP} > 10s$	20A

*CAUTION: Stresses above those listed in "Absolute Maximum Ratings" may cause permanent damage to the device. This is a stress only rating and operation of the device at these or any other conditions above those indicated in the operational sections of this specification is not implied.*

**NOTE:**

- $\theta_{JA}$  is measured with the component mounted on an evaluation PC board in free air.

**Typical Operating Conditions**

These represent the conditions under which the device was developed and are suggested as guidelines.

PARAMETER	CONDITIONS	MIN	TYP	MAX	UNITS
Ambient Temperature	HC55120, HC55150/1	0	-	70	°C
	HC55121, HC55130/1, HC55140/1, HC55142/3	-40	-	85	°C
$V_{BH}$ with Respect to GND		-58	-	-8	V
$V_{BL}$ with Respect to GND		$V_{BH}$	-	0	V
$V_{CC}$ with Respect to GND		4.75	-	5.25	V

## Electrical Specifications

$T_A = -40^{\circ}\text{C}$  to  $85^{\circ}\text{C}$ ,  $V_{CC} = +5\text{V} \pm 5\%$ ,  $V_{BH} = -48\text{V}$ ,  $V_{BL} = -24\text{V}$ ,  $\text{PTG} = \text{Open}$ ,  $R_{P1} = R_{P2} = 0\Omega$ ,  $Z_T = 120\text{k}\Omega$ ,  $R_{LIM} = 38.3\text{k}\Omega$ ,  $R_{OH} = 40\text{k}\Omega$ ,  $C_H = 0.1\mu\text{F}$ ,  $C_{DC} = 4.7\mu\text{F}$ ,  $C_{RT}/\text{REV} = 0.47\mu\text{F}$ ,  $\text{GND} = 0\text{V}$ ,  $R_L = 600\Omega$ . Unless Otherwise Specified, (●) Sym applies to the part. (NA) symbol used to indicate the test does not apply to the part.

PARAMETER	TEST CONDITIONS	MIN	TYP	MAX	UNITS	HC55120	HC55121	HC55130/1
<b>2-WIRE PORT</b>								
Overload Level, Off Hook Forward and Reverse	1% THD, $I_{DCMET} \geq 18\text{mA}$ (Note 2, Figure 1)	3.2	-	-	$V_{PEAK}$	Forward Only	●	Forward Only
Overload Level, On Hook Forward and Reverse	1% THD, $I_{DCMET} \leq 5\text{mA}$ (Note 3, Figure 1)	1.3	-	-	$V_{PEAK}$	Forward Only	●	Forward Only
Input Impedance (Into Tip and Ring)		-	$Z_T/200$	-	$\Omega$	●	●	●
Longitudinal Impedance (Tip, Ring) Forward and Reverse	$0 < f < 100\text{Hz}$ (Note 4, Figure 2)	-	0	-	$\Omega/\text{Wire}$	Forward Only	●	Forward Only

## LONGITUDINAL CURRENT LIMIT (TIP, RING)

On-Hook, Off-Hook (Active),

$R_L = 736\Omega$

Forward and Reverse

No False Detections, (Loop Current),  $\text{LB} > 45\text{dB}$  (Notes 5, 6, Figures 3A, 3B)

Forward Only

Forward Only

Forward Only

Forward Only

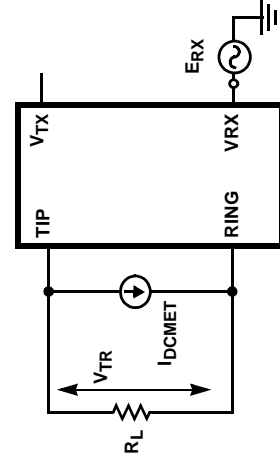

FIGURE 1. OVERLOAD LEVEL (OFF HOOK, ON HOOK)

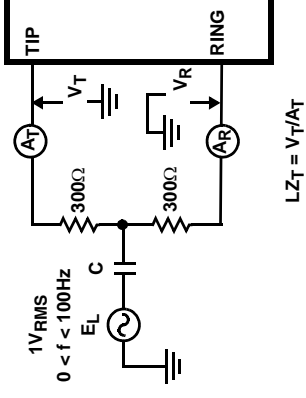

FIGURE 2. LONGITUDINAL IMPEDANCE

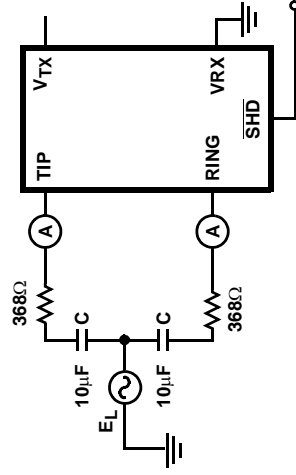

FIGURE 3A. LONGITUDINAL CURRENT LIMIT ON-HOOK (ACTIVE)

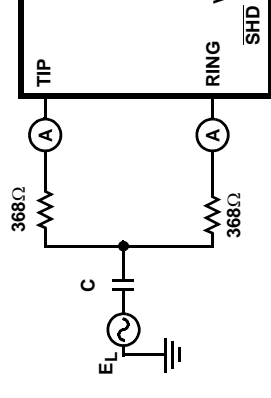

FIGURE 3B. LONGITUDINAL CURRENT LIMIT

## Electrical Specifications

$T_A = -40^{\circ}\text{C}$  to  $85^{\circ}\text{C}$ ,  $V_{CC} = +5\text{V} \pm 5\%$ ,  $V_{BH} = -48\text{V}$ ,  $V_{BL} = -24\text{V}$ ,  $\text{PTG} = \text{Open}$ ,  $R_{P1} = R_{P2} = 0\Omega$ ,  $Z_T = 120\text{k}\Omega$ ,  $R_{LIM} = 38.3\text{k}\Omega$ ,  $R_{OH} = 40\text{k}\Omega$ ,  $C_H = 0.1\mu\text{F}$ ,  $C_{DC} = 4.7\mu\text{F}$ ,  $\text{CRT/REV} = 0.47\mu\text{F}$ ,  $\text{GND} = 0\text{V}$ ,  $R_L = 600\Omega$ . Unless Otherwise Specified. (●) Sym applies to the part. (NA) symbol used to indicate the test does not apply to the part. (Continued)

PARAMETER	TEST CONDITIONS	MIN	TYP	MAX	UNITS	HC55120	HC55121	HC55130/1
<b>OFF-HOOK LONGITUDINAL BALANCE</b>								
Longitudinal to Metallic (Note 7) Forward and Reverse	IEEE 455 - 1985, $R_{LR}$ , $R_{LT} = 368\Omega$ Normal Polarity:					Forward Only	MIN	MIN
	0.2kHz < f < 1.0kHz, $0^{\circ}\text{C}$ to $70^{\circ}\text{C}$	-	-	-	dB	53	NA	Forward Only
	1.0kHz < f < 3.4kHz, $0^{\circ}\text{C}$ to $70^{\circ}\text{C}$	-	-	-	dB	53	NA	NA
	0.2kHz < f < 1.0kHz, $-40^{\circ}\text{C}$ to $85^{\circ}\text{C}$	-	-	-	dB	NA	53	63
	1.0kHz < f < 3.4kHz, $-40^{\circ}\text{C}$ to $85^{\circ}\text{C}$	-	-	-	dB	NA	53	58
	Reverse Polarity 0.2kHz < f < 3.4kHz, (Figure 4)	-	-	-	dB	NA	53	NA
Longitudinal to Metallic (Note 7) Forward and Reverse	$R_{LR}$ , $R_{LT} = 300\Omega$ , Normal Polarity:					Forward Only	MIN	MIN
	0.2kHz < f < 1.0kHz, $0^{\circ}\text{C}$ to $70^{\circ}\text{C}$	-	-	-	dB	53	NA	Forward Only
	1.0kHz < f < 3.4kHz, $0^{\circ}\text{C}$ to $70^{\circ}\text{C}$	-	-	-	dB	53	NA	NA
	0.2kHz < f < 1.0kHz, $-40^{\circ}\text{C}$ to $85^{\circ}\text{C}$	-	-	-	dB	NA	53	63
	1.0kHz < f < 3.4kHz, $-40^{\circ}\text{C}$ to $85^{\circ}\text{C}$	-	-	-	dB	NA	53	58
	Reverse Polarity 0.2kHz < f < 3.4kHz, (Figure 4)	-	-	-	dB	NA	53	NA
Longitudinal to 4-Wire (Note 9) (Forward and Reverse)	Normal Polarity:					Forward Only	MIN	MIN
	0.2kHz < f < 1.0kHz, $0^{\circ}\text{C}$ to $70^{\circ}\text{C}$	-	-	-	dB	53	NA	Forward Only
	1.0kHz < f < 3.4kHz, $0^{\circ}\text{C}$ to $70^{\circ}\text{C}$	-	-	-	dB	53	NA	NA
	0.2kHz < f < 1.0kHz, $-40^{\circ}\text{C}$ to $85^{\circ}\text{C}$	-	-	-	dB	NA	53	63
	1.0kHz < f < 3.4kHz, $-40^{\circ}\text{C}$ to $85^{\circ}\text{C}$	-	-	-	dB	NA	53	58
	Reverse Polarity 0.2kHz < f < 3.4kHz, (Figure 4)	-	-	-	dB	NA	53	NA
Metallic to Longitudinal (Note 10) Forward and Reverse	FCC Part 68, Para 68.310 (Note 8) 0.2kHz < f < 3.4kHz, (Figure 5)	40	50	-	dB	Forward Only	●	Forward Only
	0.2kHz < f < 3.4kHz, (Figure 5)	40	-	-	dB	Forward Only	●	Forward Only

### Electrical Specifications

$T_A = -40^{\circ}\text{C}$  to  $85^{\circ}\text{C}$ ,  $V_{CC} = +5\text{V} \pm 5\%$ ,  $V_{BH} = -48\text{V}$ ,  $V_{BL} = -24\text{V}$ ,  $\text{PTG} = \text{Open}$ ,  $R_{P1} = R_{P2} = 0\Omega$ ,  $Z_T = 120\text{k}\Omega$ ,  $R_{LIM} = 38.3\text{k}\Omega$ ,  $R_{OH} = 40\text{k}\Omega$ ,  $C_H = 0.1\mu\text{F}$ ,  $C_{DC} = 4.7\mu\text{F}$ ,  $C_{RT}/\text{REV} = 0.47\mu\text{F}$ ,  $\text{GND} = 0\text{V}$ ,  $R_L = 600\Omega$ . Unless Otherwise Specified. (●) Symbol applies to the part. (NA) symbol used to indicate the test does not apply to the part. (Continued)

PARAMETER	TEST CONDITIONS	MIN	TYP	MAX	UNITS	HC55120	HC55121	HC55130/1
2-Wire Return Loss Forward and Reverse		30	35	-	dB	Forward Only	Forward Only	Forward Only
		23	25	-	dB	Forward Only	●	Forward Only
		21	23	-	dB	Forward Only	●	Forward Only
<b>FIGURE 4. LONGITUDINAL TO METALLIC AND LONGITUDINAL TO 4-WIRE BALANCE</b>								
<b>TIP IDLE VOLTAGE (User Programmable)</b>								
TIPX Idle Voltage Forward and Reverse	Active, $I_L < 5\text{mA}$	-2.6	-2.2	-1.8	V	Forward Only	●	Forward Only
<b>RING IDLE VOLTAGE (User Programmable)</b>								
RINGX Idle Voltage Forward and Reverse	Active, $I_L < 5\text{mA}$	-46.4	-45.3	-44.2	V	Forward Only	●	Forward Only
$V_{TR}$ Forward and Reverse	Tip open, $I_L < 5\text{mA}$	-46.4	-45.3	-44.2	V	Forward Only	●	Forward Only
	Active, $I_L < 5\text{mA}$	41	43.1	45	V	Forward Only	●	Forward Only
$V_{TR}(\text{ROH})$ Pulse Metering Forward and Reverse	Active, $I_L \geq 8.5\text{mA}$ , $R_{OH} = 50\text{k}\Omega$	36	38.1	-	V	NA	●	NA
<b>FIGURE 5. METALLIC TO LONGITUDINAL AND 4-WIRE BALANCE</b>								
<b>FIGURE 6. TWO-WIRE RETURN LOSS</b>								
<b>FIGURE 7. OVERLOAD LEVEL (4-WIRE TRANSMIT P VOLTAGE AND HARMONIC DISTORTION</b>								

## Electrical Specifications

$T_A = -40^\circ\text{C}$  to  $85^\circ\text{C}$ ,  $V_{CC} = +5\text{V} \pm 5\%$ ,  $V_{BH} = -48\text{V}$ ,  $V_{BL} = -24\text{V}$ ,  $PTG = \text{Open}$ ,  $R_{P1} = R_{P2} = 0\Omega$ ,  $Z_T = 120\text{k}\Omega$ ,  $R_{LIM} = 38.3\text{k}\Omega$ ,  $R_{OH} = 40\text{k}\Omega$ ,  $C_H = 0.1\mu\text{F}$ ,  $C_{DC} = 4.7\mu\text{F}$ ,  $C_{RT}/\text{REV} = 0.47\mu\text{F}$ ,  $GND = 0\text{V}$ ,  $R_L = 600\Omega$ . Unless Otherwise Specified. (●) Sym applies to the part. (NA) symbol used to indicate the test does not apply to the part. (Continued)

PARAMETER	TEST CONDITIONS	MIN	TYP	MAX	UNITS	HC55120	HC55121	HC55130/1
<b>4-WIRE TRANSMIT PORT (VTX)</b>								
Overload Level, Off Hook ( $I_L \geq 18\text{mA}$ ) Forward and Reverse	( $Z_L > 20\text{k}\Omega$ , IL 1% THD) (Note 13, Figure 7) $T_A = 0^\circ\text{C}$ to $85^\circ\text{C}$ $T_A = -40^\circ\text{C}$ to $0^\circ\text{C}$	3.2	-	-	V <sub>PEAK</sub>	Forward Only	●	Forward Only
		3.0	-	-	V <sub>PEAK</sub>			
Overload Level, On Hook ( $I_L \leq 5\text{mA}$ ) Forward and Reverse	( $Z_L > 20\text{k}\Omega$ , 1% THD) (Note 14, Figure 7)	1.3	-	-	V <sub>PEAK</sub>	Forward Only	●	Forward Only
		-200	-	200	mV	Forward Only	●	Forward Only
V <sub>TX</sub> Output Offset Voltage Forward and Reverse	$E_G = 0$ , $Z_L = \infty$ , (Note 15, Figure 7)	-	0.1	1	$\Omega$	●	●	●
Output Impedance (Guaranteed by Design)	$0.2\text{kHz} < f < 03.4\text{kHz}$	-	-	-	$\Omega$			
<b>4-WIRE RECEIVE PORT (VRX)</b>								
VRX Input Impedance (Guaranteed by Design)	$0.2\text{kHz} < f < 3.4\text{kHz}$	-	500	600	k $\Omega$	●	●	●
<b>FREQUENCY RESPONSE (OFF-HOOK)</b>								
2-Wire to 4-Wire Forward and Reverse	Relative to 0dBm at 1.0kHz, $E_{RX} = 0\text{V}$	-0.15	-	0.15	dB	Forward Only		Forward Only
	$0.3\text{kHz} < f < 3.4\text{kHz}$							
	$f = 8.0\text{kHz}$ (Note 16, Figure 8)	-	0.24	0.5	dB		●	
	$f = 12\text{kHz}$ (Note 16, Figure 8)	-	0.58	1.0	dB			
4-Wire to 2-Wire Forward and Reverse	Relative to 0dBm at 1.0kHz, $E_G = 0\text{V}$	-0.15	-	0.15	dB	Forward Only		Forward Only
	$0.3\text{kHz} < f < 3.4\text{kHz}$							
	$f = 8\text{kHz}$ (Note 17, Figure 8)	-0.5	0.24	-	dB		●	
	$f = 12\text{kHz}$ (Note 17, Figure 8)	-1.0	0.58	-	dB			
4-Wire to 4-Wire Forward and Reverse	Relative to 0dBm at 1.0kHz, $E_G = 0\text{V}$	-0.15	-	0.15	dB	Forward Only		Forward Only
	$0.3\text{kHz} < f < 3.4\text{kHz}$ (Note 18, Figure 8)							
	$8\text{kHz}$ , $12\text{kHz}$ , $16\text{kHz}$ (Note 18, Figure 8)	-0.5	0	0.5	dB		●	

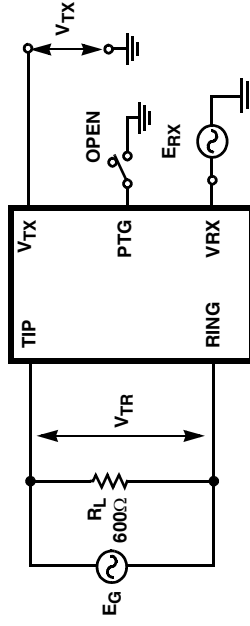

FIGURE 8. FREQUENCY RESPONSE, INSERTION LOSS, GAIN TRACKING AND HARMONIC DISTORTION

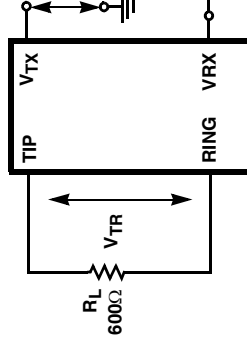

FIGURE 9. IDLE CHANNEL NOISE

## Electrical Specifications

$T_A = -40^\circ\text{C}$  to  $85^\circ\text{C}$ ,  $V_{CC} = +5\text{V} \pm 5\%$ ,  $V_{BH} = -48\text{V}$ ,  $V_{BL} = -24\text{V}$ ,  $\text{PTG} = \text{Open}$ ,  $R_{P1} = R_{P2} = 0\Omega$ ,  $Z_T = 120\text{k}\Omega$ ,  $R_{LIM} = 38.3\text{k}\Omega$ ,  $R_{OH} = 40\text{k}\Omega$ ,  $C_H = 0.1\mu\text{F}$ ,  $C_{DC} = 4.7\mu\text{F}$ ,  $\text{CRT/REV} = 0.47\mu\text{F}$ ,  $\text{GND} = 0\text{V}$ ,  $R_L = 600\Omega$ . Unless Otherwise Specified. (●) Sym applies to the part. (NA) symbol used to indicate the test does not apply to the part. **(Continued)**

PARAMETER	TEST CONDITIONS	MIN	TYP	MAX	UNITS	HC55120	HC55121	HC55130/1
<b>INSERTION LOSS</b>								
2-Wire to 4-Wire Forward and Reverse	0dBm, 1kHz	-0.2	-	0.2	dB	Forward Only	●	Forward Only
	PTG = Open (Note 19, Figure 8)							
4-Wire to 2-Wire Forward and Reverse	0dBm, 1kHz (Note 21, Figure 8)	-0.2	-	0.2	dB	Forward Only	●	Forward Only
	PTG = GND (Note 20, Figure 8)	-6.22	-6.02	-5.82	dB			
<b>GAIN TRACKING (Ref = -10dBm, at 1.0kHz)</b>								
2-Wire to 4-Wire Forward and Reverse	-40dBm to +3dBm (Note 22, Figure 8)	-0.1	-	0.1	dB	Forward Only	●	Forward Only
	-55dBm to -40dBm (Note 22, Figure 8)	-0.2	-	0.2	dB			
4-Wire to 2-Wire Forward and Reverse	-40dBm to +3dBm (Note 23, Figure 8)	-0.1	-	0.1	dB	Forward Only	●	Forward Only
	-55dBm to -40dBm (Note 23, Figure 8)	-0.2	-	0.2	dB			
<b>NOISE</b>								
Idle Channel Noise at 2-Wire Forward and Reverse	C-Message Weighting	-	10.5	13	dBmC	Forward Only	●	Forward Only
	Psophometric Weighting (Note 24, Note 30, Figure 9)	-	-79.5	-77	dBmp			
Idle Channel Noise at 4-Wire Forward and Reverse	C-Message Weighting	-	10.5	13	dBmC	Forward Only	●	Forward Only
	Psophometrical Weighting (Note 25, Note 30, Figure 9)	-	-79.5	-77	dBmp			
<b>HARMONIC DISTORTION</b>								
2-Wire to 4-Wire Forward and Reverse	0dBm, 0.3kHz to 3.4kHz (Note 26, Figure 7)	-	-67	-50	dB	Forward Only	●	Forward Only
	4-Wire to 2-Wire Forward and Reverse	-	-67	-50	dB	Forward Only	●	Forward Only

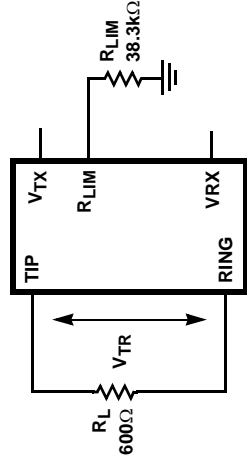

FIGURE 10. CONSTANT LOOP CURRENT TOLERANCE

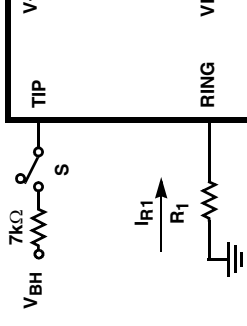

FIGURE 11. TIPX VOLTAGE

## Electrical Specifications

$T_A = -40^{\circ}\text{C}$  to  $85^{\circ}\text{C}$ ,  $V_{CC} = +5\text{V} \pm 5\%$ ,  $V_{BH} = -48\text{V}$ ,  $V_{BL} = -24\text{V}$ ,  $\text{PTG} = \text{Open}$ ,  $R_{P1} = R_{P2} = 0\Omega$ ,  $Z_T = 120\text{k}\Omega$ ,  $R_{LIM} = 38.3\text{k}\Omega$ ,  $R_{OH} = 40\text{k}\Omega$ ,  $C_H = 0.1\mu\text{F}$ ,  $C_{DC} = 4.7\mu\text{F}$ ,  $C_{RT}/\text{REV} = 0.47\mu\text{F}$ ,  $\text{GND} = 0\text{V}$ ,  $R_L = 600\Omega$ . Unless Otherwise Specified. (●) Sym applies to the part. (NA) symbol used to indicate the test does not apply to the part. (Continued)

PARAMETER	TEST CONDITIONS	MIN	TYP	MAX	UNITS	HC55120	HC55121	HC55130/1
<b>BATTERY FEED CHARACTERISTICS</b>								
Constant Loop Current Tolerance	$18\text{mA} \leq I_L \leq 45\text{mA}$ , (Note 27, Figure 10)	0.92 $I_L$	$I_L$	1.08 $I_L$	mA	Forward Only	●	Forward Only
$I_L = 26.5\text{mA}$ , $R_{LIM} = 38.3\text{k}\Omega$ Forward and Reverse								
Tip Open State TIPX Leakage Current	S = Closed (Figure 11)	-	-	-200	$\mu\text{A}$	●	●	●
Tip Open State RINGX Current	$R_1 = 0\Omega$ , $V_{BH} = -48\text{V}$ , $R_{LIM} = 38.3\text{k}\Omega$ $R_1 = 2.5\text{k}\Omega$ , $V_{BH} = -48\text{V}$ (Figure 11)	22.6 15.5	26.8 17.1	31 18.2	mA mA	●	●	●
Tip Open State RINGX Voltage	$5\text{mA} <  R_1  < 26\text{mA}$ (Figure 11)	-	42.8	-	V	●	●	●
Tip Voltage (Ground Start)	Active State, (S Open) $R_1 = 150\Omega$ (Figure 11)	-5.3	-4.8	-4.3	V	NA	NA	NA
Tip Voltage (Ground Start)	Active State, (S Closed) Tip Lead to -48V Through $7\text{k}\Omega$ , Ring Lead to Ground Through $150\Omega$ (Figure 11)	-5.3	-4.8	-4.3	V	NA	NA	NA
Open Circuit State Loop Current	(Active) $R_L = 0\Omega$	-20	0	20	$\mu\text{A}$	●	●	●
<b>LOOP CURRENT DETECTOR</b>								
Programmable Threshold Forward and Reverse	$I_{LTh} = (500/R_D) \geq 5\text{mA}$ , $I_{LTh} = 8.5\text{mA}$ $R_D = 58.8\text{k}\Omega$	0.9 $I_{LTh}$	$I_{LTh}$	1.1 $I_{LTh}$	mA	Forward Only	●	Forward Only
<b>GROUND KEY DETECTOR</b>								
Ground Key Detector Threshold Tip/Ring Current Difference	Tip Open Active (Note 29, $R_1 = 2.5\text{k}\Omega$ , Figure 12)	5 12.5	8 20	11 27.5	mA mA	●	●	NA
<b>LINE VOLTAGE MEASUREMENT</b>								
Pulse Width ( $\overline{\text{GKD\_LVM}}$ )	Pulse Width = (20)( $C_{REV...}/I_{LIM}$ )	0.32	0.36	0.4	ms/V	NA	NA	NA
<b>RING TRIP DETECTOR (DT, DR)</b>								
Ring Trip Comparator Current	Source Res = $2\text{M}\Omega$	-	2	-	$\mu\text{A}$	●	●	●
Input Common-Mode Range	Source Res = $2\text{M}\Omega$	-	-	$\pm 200$	V	●	●	●

## Electrical Specifications

$T_A = -40^\circ\text{C}$  to  $85^\circ\text{C}$ ,  $V_{CC} = +5\text{V} \pm 5\%$ ,  $V_{BH} = -48\text{V}$ ,  $V_{BL} = -24\text{V}$ ,  $\text{PTG} = \text{Open}$ ,  $R_{P1} = R_{P2} = 0\Omega$ ,  $Z_T = 120\text{k}\Omega$ ,  $R_{LIM} = 38.3\text{k}\Omega$ ,  $R_{OH} = 40\text{k}\Omega$ ,  $C_H = 0.1\mu\text{F}$ ,  $C_{DC} = 4.7\mu\text{F}$ ,  $C_{RT/REV} = 0.47\mu\text{F}$ ,  $GND = 0\text{V}$ ,  $R_L = 600\Omega$ . Unless Otherwise Specified. (●) Symbol applies to the part. (NA) symbol used to indicate the test does not apply to the part. **(Continued)**

PARAMETER	TEST CONDITIONS	MIN	TYP	MAX	UNITS	HC55120	HC55121	HC55130/1
<b>RING RELAY DRIVER</b>								
$V_{SAT}$ at 30mA	$I_{OL} = 30\text{mA}$	-	0.2	0.5	V	●	●	●
$V_{SAT}$ at 40mA	$I_{OL} = 40\text{mA}$	-	0.52	0.8	V	●	●	●
Off State Leakage Current	$V_{OH} = 13.2\text{V}$	-	0.1	10	$\mu\text{A}$	●	●	●
<b>TEST RELAY DRIVER (TRLY1, TRLY2)</b>								
$V_{SAT}$ at 30mA	$I_{OL} = 30\text{mA}$	-	0.3	0.5	V	NA	NA	NA/●
$V_{SAT}$ at 40mA	$I_{OL} = 40\text{mA}$	-	0.65	1.3	V	NA	NA	NA/●
Off State Leakage Current	$V_{OH} = 13.2\text{V}$	-	-	10	$\mu\text{A}$	NA	NA	NA/●

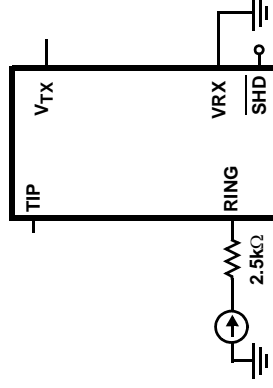

FIGURE 12. GROUND KEY DETECT

## DIGITAL INPUTS (C1, C2, C3, C4, C5)

Input Low Voltage, $V_{IL}$		0	-	0.8	V	●	●	●
Input High Voltage, $V_{IH}$		2.0	-	$V_{CC}$	V	●	●	●
Input Low Current, $I_{IL}$	$V_{IL} = 0.4\text{V}$	-	-	-10	$\mu\text{A}$	●	●	●
Input High Current, $I_{IH}$	$V_{IH} = 2.5\text{V}$	-	25	50	$\mu\text{A}$	●	●	●
<b>DETECTOR OUTPUTS (SHD, GKD, LVM)</b>								
SHD Output Low Voltage, $V_{OL}$ Forward, Reverse	$I_{OL} = 1\text{mA}$	-	-	0.5	V	Forward Only	●	Forward Only
SHD Output High Voltage, $V_{OH}$ Forward, Reverse	$I_{OH} = 100\mu\text{A}$	2.7	-	-	V	Forward Only	●	Forward Only
GKD_LVM Output Low Voltage, $V_{OL}$ Forward and Tip Open	$I_{OL} = 1\text{mA}$ $R_1 = 2.5\text{k}\Omega$ (Figure 11)	-	-	0.5	V	$\overline{\text{GKD}}$	$\overline{\text{GKD}}$	NA
GKD_LVM Output High Voltage, $V_{OH}$ Forward and Tip Open	$I_{OH} = 100\mu\text{A}$	2.7	-	-	V	$\overline{\text{GKD}}$	$\overline{\text{GKD}}$	NA
Internal Pull-Up Resistor		-	15	-	$\text{k}\Omega$	●	●	●

## Electrical Specifications

$T_A = -40^\circ\text{C}$  to  $85^\circ\text{C}$ ,  $V_{CC} = +5\text{V} \pm 5\%$ ,  $V_{BH} = -48\text{V}$ ,  $V_{BL} = -24\text{V}$ ,  $\text{PTG} = \text{Open}$ ,  $R_{P1} = R_{P2} = 0\Omega$ ,  $Z_T = 120\text{k}\Omega$ ,  $R_{LIM} = 38.3\text{k}\Omega$ ,  $R_{OH} = 40\text{k}\Omega$ ,  $C_H = 0.1\mu\text{F}$ ,  $C_{DC} = 4.7\mu\text{F}$ ,  $C_{RT}/\text{REV} = 0.47\mu\text{F}$ ,  $\text{GND} = 0\text{V}$ ,  $R_L = 600\Omega$ . Unless Otherwise Specified. (●) Sym applies to the part. (NA) symbol used to indicate the test does not apply to the part. **(Continued)**

PARAMETER	TEST CONDITIONS	MIN	TYP	MAX	UNITS	HC55120	HC55121	HC55130/1
<b>POWER DISSIPATION (<math>V_{BH} = -48\text{V}</math>, <math>V_{BL} = -24\text{V}</math>)</b>								
Open Circuit State	C1, C2, C3 = 0, 0, 0	-	25	-	mW	Forward Only	●	Forward Only
On-Hook, Active	C1, C2, C3 = 0, 1, 0						●	
Forward and Reverse	C1, C2, C3 = 1, 1, 0 $I_L = 0\text{mA}$ , Longitudinal Current = 0mA	-	52	-	mW	Forward Only	●	Forward Only
<b>POWER SUPPLY CURRENTS (<math>V_{BH} = -48\text{V}</math>, <math>V_{BL} = -24\text{V}</math>)</b>								
$V_{CC}$ Current, $I_{CC}$	Open Circuit State	-	2.25	3.0	mA	Forward Only	●	Forward Only
$V_{BH}$ Current, $I_{BH}$		-	0.3	0.45	mA	Forward Only	●	Forward Only
$V_{BL}$ Current, $I_{BL}$		-	0.022	0.035	mA	Forward Only	●	Forward Only
$V_{CC}$ Current, $I_{CC}$	Active State	-	2.7	3.6	mA	Forward Only	●	Forward Only
Forward and Reverse	$I_L = 0\text{mA}$ , Longitudinal Current = 0mA	-	0.8	1.06	mA	Forward Only	●	Forward Only
$V_{BH}$ Current, $I_{BH}$		-	-	-	mA	Forward Only	●	Forward Only
Forward and Reverse		-	-	0.01	mA	Forward Only	●	Forward Only
<b>POWER SUPPLY REJECTION RATIOS</b>								
$V_{CC}$ to 2 or 4 Wire Port	Active State $R_L = 600\Omega$	-	40	-	dB	Forward Only	●	Forward Only
Forward and Reverse	$50\text{Hz} < f < 3400\text{Hz}$ , $V_{IN} = 100\text{mV}$	-	40	-	dB	Forward Only	●	Forward Only
$V_{BH}$ to 2 or 4 Wire Port		-	40	-	dB	Forward Only	●	Forward Only
Forward and Reverse		-	40	-	dB	Forward Only	●	Forward Only
$V_{BL}$ to 2 or 4 Wire Port		-	40	-	dB	Forward Only	●	Forward Only
Forward and Reverse		-	40	-	dB	Forward Only	●	Forward Only
<b>TEMPERATURE GUARD</b>								
Junction Threshold Temperature		-	175	-	$^\circ\text{C}$	●	●	●

**Notes**

2. **Overload Level (Two-Wire Port, Off Hook)** - The overload level is specified at the 2-wire port ( $V_{TR}$ ) with the signal source at the 4-wire receive port ( $E_{RX}$ ).  $R_L = 600\Omega$ ,  $I_{DCMET} \geq 18mA$ . Increase the amplitude of  $E_{RX}$  until 1% THD is measured at  $V_{TR}$ . Reference Figure 1.
3. **Overload Level (Two-Wire Port, On Hook)** - The overload level is specified at the 2-wire port ( $V_{TR}$ ) with the signal source at the 4-wire receive port ( $E_{RX}$ ).  $R_L = \infty$ ,  $I_{DCMET} = 0mA$ . Increase the amplitude of  $E_{RX}$  until 1% THD is measured at  $V_{TR}$ . Reference Figure 1.
4. **Longitudinal Impedance** - The longitudinal impedance is computed using the following equations, where TIP and RING voltages are referenced to ground.  $L_{ZT}$ ,  $L_{ZR}$ ,  $V_T$ ,  $V_R$ ,  $A_R$  and  $A_T$  are defined in Figure 2.  
 (TIP)  $L_{ZT} = V_T/A_T$   
 (RING)  $L_{ZR} = V_R/A_R$   
 where:  $E_L = 1V_{RMS}$  (0Hz to 100Hz)
5. **Longitudinal Current Limit (On-Hook Active)** - On-Hook longitudinal current limit is determined by increasing the (60Hz) amplitude of  $E_L$  (Figure 3A) until the 2-wire longitudinal current is greater than  $28mA_{RMS}/Wire$ . Under this condition,  $\overline{SHD}$  pin remains low (no false detection) and the 2-wire to 4-wire longitudinal balance is verified to be greater than 45dB ( $LB_{2-4} = 20\log V_{TX}/E_L$ ).
6. **Longitudinal Current Limit (Off-Hook Active)** - Off-Hook longitudinal current limit is determined by increasing the (60Hz) amplitude of  $E_L$  (Figure 3B) until the 2-wire longitudinal current is greater than  $28mA_{RMS}/Wire$ . Under this condition,  $\overline{SHD}$  pin remains high (no false detection) and the 2-wire to 4-wire longitudinal balance is verified to be greater than 45dB ( $LB_{2-4} = 20\log V_{TX}/E_L$ ).
7. **Longitudinal to Metallic Balance** - The longitudinal to metallic balance is computed using the following equation:  
 $BLME = 20 \log (E_L/V_{TR})$ , where:  $E_L$  and  $V_{TR}$  are defined in Figure 4.
8. **Metallic to Longitudinal FCC Part 68, Para 68.310** - The metallic to longitudinal balance is defined in this spec.
9. **Longitudinal to Four-Wire Balance** - The longitudinal to 4-wire balance is computed using the following equation:  
 $BLFE = 20 \log (E_L/V_{TX})$ ,  $E_L$  and  $V_{TX}$  are defined in Figure 4.
10. **Metallic to Longitudinal Balance** - The metallic to longitudinal balance is computed using the following equation:  
 $BMLE = 20 \log (E_{TR}/V_L)$ ,  $E_{RX} = 0$   
 where:  $E_{TR}$ ,  $V_L$  and  $E_{RX}$  are defined in Figure 5.
11. **Four-Wire to Longitudinal Balance** - The 4-wire to longitudinal balance is computed using the following equation:  
 $BFLE = 20 \log (E_{RX}/V_L)$ ,  $E_{TR} = \text{source is removed}$ .  
 where:  $E_{RX}$ ,  $V_L$  and  $E_{TR}$  are defined in Figure 5.
12. **Two-Wire Return Loss** - The 2-wire return loss is computed using the following equation:  
 $r = -20 \log (2V_M/V_S)$  where:  $Z_D = \text{The desired impedance; e.g., the characteristic impedance of the line, nominally } 600\Omega$ . (Reference Figure 6).
13. **Overload Level (4-Wire Port Off-Hook)** - The overload level is specified at the 4-wire transmit port ( $V_{TX}$ ) with the signal source ( $E_G$ ) at the 2-wire port,  $Z_L = 20k\Omega$ ,  $R_L = 600\Omega$  (Reference Figure 7). Increase the amplitude of  $E_G$  until 1% THD is measured at  $V_{TX}$ . Note the PTG pin is open, and the gain from the 2-wire port to the 4-wire port is equal to 1.
14. **Overload Level (4-Wire Port On-Hook)** - The overload level is specified at the 4-wire transmit port ( $V_{TX}$ ) with the signal source ( $E_G$ ) at the 2-wire port,  $Z_L = 20k\Omega$ ,  $R_L = \infty$  (Reference Figure 7). Increase the amplitude of  $E_G$  until 1% THD is measured at  $V_{TX}$ . Note the PTG pin is open, and the gain from the 2-wire port to the 4-wire port is equal to 1.
15. **Output Offset Voltage** - The output offset voltage is specified with the following conditions:  $E_G = 0$ ,  $R_L = 600\Omega$ ,  $Z_L = \infty$  and is measured at  $V_{TX}$ .  $E_G$ ,  $R_L$ ,  $V_{TX}$  and  $Z_L$  are defined in Figure 7.
16. **Two-Wire to Four-Wire Frequency Response** - The 2-wire to 4-wire frequency response is measured with respect to  $E_G = 0dBm$  at 1.0kHz,  $E_{RX} = 0V$  (VRX input floating),  $R_L = 600\Omega$ . The frequency response is computed using the following equation:  
 $F_{2-4} = 20 \log (V_{TX}/V_{TR})$ , vary frequency from 300Hz to 3.4kHz and compare to 1kHz reading.  
 $V_{TX}$ ,  $V_{TR}$ ,  $R_L$  and  $E_G$  are defined in Figure 8.
17. **Four-Wire to Two-Wire Frequency Response** - The 4-wire to 2-wire frequency response is measured with respect to  $E_{RX} = 0dBm$  at 1.0kHz,  $E_G$  source removed from circuit,  $R_L = 600\Omega$ . The frequency response is computed using the following equation:  
 $F_{4-2} = 20 \log (V_{TR}/E_{RX})$ , vary frequency from 300Hz to 3.4kHz and compare to 1kHz reading.  
 $V_{TR}$ ,  $R_L$  and  $E_{RX}$  are defined in Figure 8.
18. **Four-Wire to Four-Wire Frequency Response** - The 4-wire to 4-wire frequency response is measured with respect to  $E_{RX} = 0dBm$  at 1.0kHz,  $E_G$  source removed from circuit,  $R_L = 600\Omega$ . The frequency response is computed using the following equation:  
 $F_{4-4} = 20 \log (V_{TX}/E_{RX})$ , vary frequency from 300Hz to 3.4kHz and compare to 1kHz reading.  
 $V_{TX}$ ,  $R_L$  and  $E_{RX}$  are defined in Figure 8.
19. **Two-Wire to Four-Wire Insertion Loss (PTG = Open)** - The 2-wire to 4-wire insertion loss is measured with respect to  $E_G = 0dBm$  at 1.0kHz input signal,  $E_{RX} = 0$  (VRX input floating),  $R_L = 600\Omega$  and is computed using the following equation:  
 $L_{2-4} = 20 \log (V_{TX}/V_{TR})$   
 where:  $V_{TX}$ ,  $V_{TR}$ ,  $R_L$  and  $E_G$  are defined in Figure 8. (Note: The fuse resistors,  $R_F$ , impact the insertion loss. The specified insertion loss is for  $R_{F1} = R_{F2} = 0$ ).
20. **Two-Wire to Four-Wire Insertion Loss (PTG = AGND)** - The 2-wire to 4-wire insertion loss is measured with respect to  $E_G = 0dBm$  at 1.0kHz input signal,  $E_{RX} = 0$  (VRX input floating),  $R_L = 600\Omega$  and is computed using the following equation:  
 $L_{2-4} = 20 \log (V_{TX}/V_{TR})$   
 where:  $V_{TX}$ ,  $V_{TR}$ ,  $R_L$  and  $E_G$  are defined in Figure 8. (Note: The fuse resistors,  $R_F$ , impact the insertion loss. The specified insertion loss is for  $R_{F1} = R_{F2} = 0$ ).
21. **Four-Wire to Two-Wire Insertion Loss** - The 4-wire to 2-wire insertion loss is measured based upon  $E_{RX} = 0dBm$ , 1.0kHz input signal,  $E_G$  source removed from circuit,  $R_L = 600\Omega$  and is computed using the following equation:  
 $L_{4-2} = 20 \log (V_{TR}/E_{RX})$   
 where:  $V_{TR}$ ,  $R_L$  and  $E_{RX}$  are defined in Figure 8.
22. **Two-Wire to Four-Wire Gain Tracking** - The 2-wire to 4-wire gain tracking is referenced to measurements taken for  $E_G = -10dBm$ , 1.0kHz signal,  $E_{RX} = 0$  (VRX output floating),  $R_L = 600\Omega$  and is computed using the following equation.  
 $G_{2-4} = 20 \cdot \log (V_{TX}/V_{TR})$  vary amplitude -40dBm to +3dBm, or -55dBm to -40dBm and compare to -10dBm reading.  
 $V_{TX}$ ,  $R_L$  and  $V_{TR}$  are defined in Figure 8.

- 23. **Four-Wire to Two-Wire Gain Tracking** - The 4-wire to 2-wire gain tracking is referenced to measurements taken for  $E_{RX} = -10\text{dBm}$ , 1.0kHz signal,  $E_G$  source removed from circuit,  $R_L = 600\Omega$  and is computed using the following equation:  
 $G_{4-2} = 20 \cdot \log(V_{TR}/E_{RX})$  vary amplitude -40dBm to +3dBm, or -55dBm to -40dBm and compare to -10dBm reading.  
 $V_{TR}$ ,  $R_L$  and  $E_{RX}$  are defined in Figure 8. The level is specified at the 4-wire receive port and referenced to a  $600\Omega$  impedance level.
- 24. **Two-Wire Idle Channel Noise** - The 2-wire idle channel noise at  $V_{TR}$  is specified with the 2-wire port terminated in  $600\Omega$  ( $R_L$ ) and with the 4-wire receive port ( $V_{TX}$ ) floating (Reference Figure 9).
- 25. **Four-Wire Idle Channel Noise** - The 4-wire idle channel noise at  $V_{TX}$  is specified with the 2-wire port terminated in  $600\Omega$  ( $R_L$ ). The noise specification is with respect to a  $600\Omega$  impedance level at  $V_{TX}$ . The 4-wire receive port ( $V_{TX}$ ) floating (Reference Figure 9).

- 26. **Harmonic Distortion (2-Wire to 4-Wire)** - The harmonic distortion is measured within the voice band with the following conditions.  $E_G = 0\text{dBm}$  at 1kHz,  $R_L = 600\Omega$ . Measurement taken at  $V_{TX}$ . (Reference Figure 7).
- 27. **Harmonic Distortion (4-Wire to 2-Wire)** - The harmonic distortion is measured within the voice band with the following conditions.  $E_{RX} = 0\text{dBm}$ . Vary frequency between 300Hz and 3.4kHz,  $R_L = 600\Omega$ . Measurement taken at  $V_{TR}$ . (Reference Figure 8).
- 28. **Constant Loop Current** - The constant loop current is calculated using the following equation:  
 $I_L = 1000/R_{LIM} = V_{TR}/600$  (Reference Figure 10).
- 29. **Ground Key Detector** - (TRIGGER) Ground the Ring pin through a  $2.5k\Omega$  resistor and verify that  $\overline{GKD}$  goes low. (RESET) Disconnect the Ring pin and verify that  $\overline{GKD}$  goes high. (Hysteresis) Compare difference between trigger and reset.
- 30. **Electrical Test** - Not tested in production at  $-40^\circ\text{C}$ .

## Circuit Operation and Design Information

The UniSLIC14 family of SLICs are voltage feed current sense Subscriber Line Interface Circuits (SLIC). For short loop applications, the voltage between the tip and ring terminals varies to maintain a constant loop current. For long loop applications, the voltage between the tip and ring terminals are relatively constant and the loop current varies in proportion to the load.

The tip and ring voltages for various loop resistances are shown in Figure 13. The tip voltage remains relatively constant as the ring voltage moves to limit the loop current for short loops.

The loop current for various loop resistances are shown in Figure 14. For short loops, the loop current is limited to the programmed current limit, set by  $R_{LIM}$ . For long loop applications, the loop current varies in accordance with Ohms law for the given tip to ring voltage and the loop resistance.

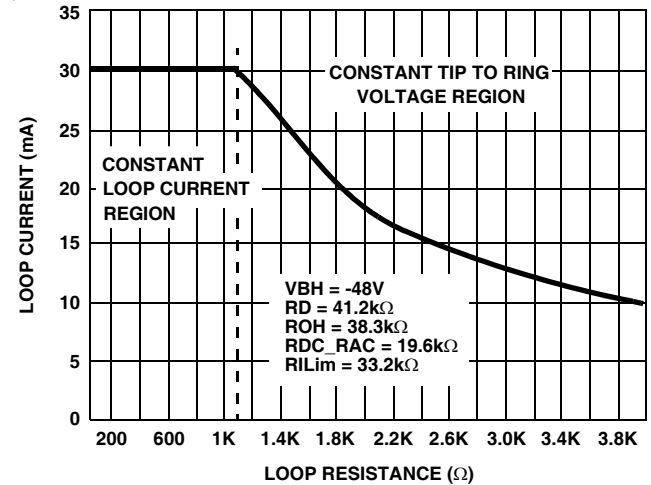

FIGURE 14. LOOP CURRENT vs LOOP RESISTANCE

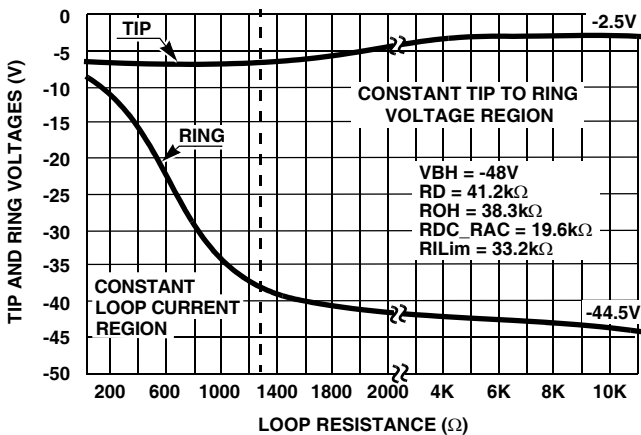
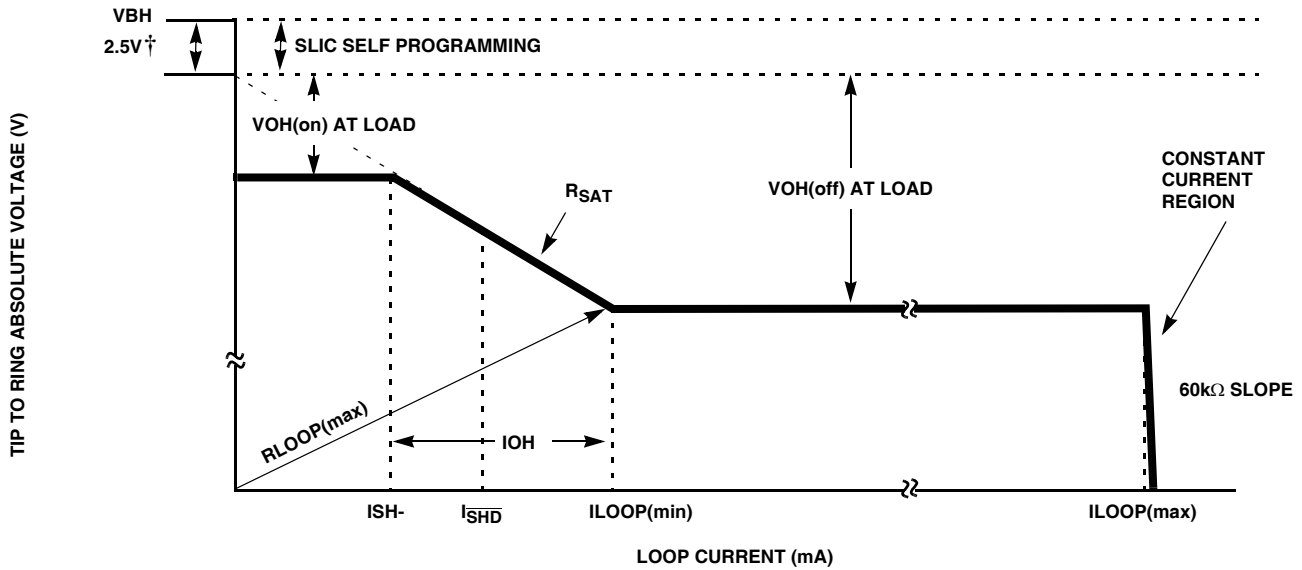

FIGURE 13. TIP AND RING VOLTAGES vs LOOP RESISTANCE

The following discussion separates the SLIC's operation into its DC and AC paths, then follows up with additional circuit and design information.

### DC Feed Curve

The DC feed curve for the UniSLIC14 family is user programmable. The user defines the on hook and off hook overhead voltages (including the overhead voltage for off hook pulse metering if applicable), the maximum and minimum loop current limits, the switch hook detect threshold and the battery voltage. From these requirements, the DC feed curve is customized for optimum operation in any given application. An Excel spreadsheet to calculate the external components can be downloaded off our web site [www.intersil.com/telecom/unislic14.xls](http://www.intersil.com/telecom/unislic14.xls).



† Internal overhead voltage automatically generated by the SLIC.

FIGURE 15. UniSLIC14 DC FEED CURVE

**On Hook Overhead Voltage**

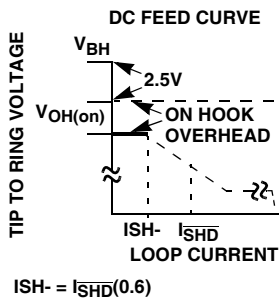

The on hook overhead voltage at the load ( $V_{OH(on)}$  at Load) is independent of the  $V_{BH}$  battery voltage. Once set, the on hook voltage remains constant as the  $V_{BH}$  battery voltage changes. The on hook voltage also remains constant over temperature and line leakages up to 0.6

times the Switch Hook Detect threshold ( $I_{SHD}$ ). The maximum loop current for a constant on hook overhead voltage is defined as  $ISH-$ .

The on hook overhead voltage, required for a given signal level at the load, must take into account the AC voltage drop across the 2 external protection resistors ( $R_P$ ) and the 2 internal sense resistors ( $R_S$ ) as shown in Figure 16. The AC on hook overload voltage is calculated using Equation 1.

$$V_{OH(on) \text{ at Load}} = V_{sp(on)} \times \left( 1 + \frac{2R_P + 2R_S}{Z_L} \right) + 1.5V \quad (\text{EQ. 1})$$

where

$V_{OH(on) \text{ at Load}}$  = On hook overhead voltage at load

$V_{sp(on)}$  = Required on hook transmission for speech

$R_P$  = Protection Resistors (Typically 30Ω)

$R_S$  = Internal Sense Resistors (40Ω)

$Z_L$  = AC load impedance for (600Ω)

1.5V = Additional on hook overhead voltage requirement

To account for any process and temperature variations in the performance of the SLIC, 1.5V is added to the overhead voltage requirement for the on hook case in Equation 1 and 2.0V for the off hook case in Equation 3. Note the 2.5V overhead is automatically generated in the SLIC and is not part of the external overhead programming.

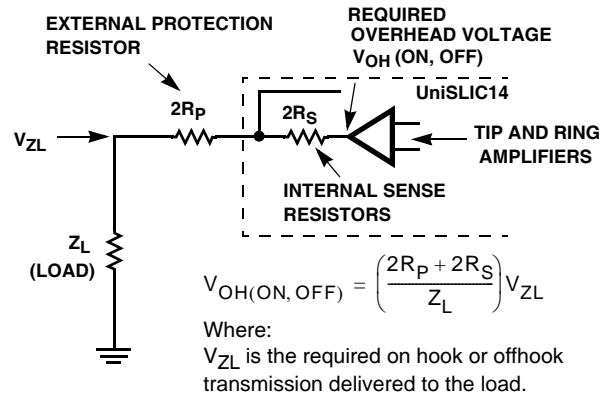
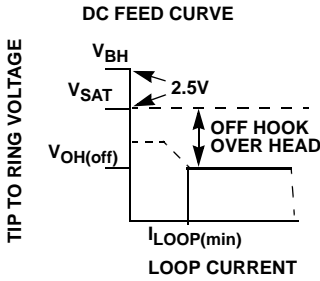

FIGURE 16. OVERHEAD VOLTAGE OF THE TIP AND RING AMPLIFIERS

$$V_{OH(ON, OFF)} = \left( \frac{2R_P + 2R_S}{Z_L} \right) V_{ZL}$$

Where:  
 $V_{ZL}$  is the required on hook or offhook transmission delivered to the load.

### Off Hook Overhead Voltage



The off hook overhead voltage  $V_{OH(off)}$  at Load is also independent of the  $V_{BH}$  battery voltage and remains constant over temperature. The required off hook overhead voltage is the sum of the AC and DC voltage drops across the internal sense resistors ( $R_S$ ), the

protection resistors ( $R_P$ ), the required (peak) off hook voltage for speech ( $V_{sp(off)}$ ) and the required (peak) off hook voltage for the pulse metering ( $V_{pm(off)}$ ), if applicable.

The off hook overhead voltage is defined in Equation 2 and calculated using Equation 3.

$$V_{OH(off) \text{ at Load}} = V_{OH(Rsense)} + V_{sp(off)} + V_{pm(off)} \quad (EQ. 2)$$

where:

$V_{OH(off) \text{ at Load}}$  = Off hook overhead voltage at load

$V_{OH(Rsense)}$  = Required overhead for the DC voltage drop across sense resistors ( $2R_S \times I_{loop(max)}$ )

$V_{sp(off)}$  = Required (peak) off hook AC voltage for speech

$V_{pm(off)}$  = Required (peak) off hook AC voltage for pulse metering

$$V_{OH(off) \text{ at Load}} = 80 \times I_{LOOP(max)} + V_{sp(off)} \times \left(1 + \frac{2R_P + 2R_S}{Z_L}\right) + V_{pm(off)} \times \left(1 + \frac{2R_P + 2R_S}{Z_{pm}}\right) + 2.0V \quad (EQ. 3)$$

where:

80 =  $2R_S + 2R_{INT}$  (reference Figure 17)

$Z_{pm}$  = Pulse metering load impedance (typically 200 $\Omega$ ).

2.0V = Additional off hook overhead voltage requirement

### $R_{SAT}$ Resistance Calculation

The  $R_{SAT}$  resistance of the DC feed curve is used to determine the value of the RDC\_RAC resistor (Equation 6). The value of this resistor has an effect on both the on hook and off hook overheads. In most applications the off hook condition will dominate the overhead requirements. Therefore, we'll start by calculating the  $R_{SAT}$  value for the off hook conditions and then verify that the on hook conditions are also satisfied.

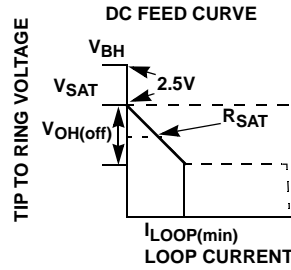

When considering the Off hook condition,  $R_{SAT}$  is equal to  $V_{OH(off)}$  at Load divided by  $I_{loop(min)}$  (Equation 4).

For the given system requirements (recommended application circuit in back of data sheet):  $I_{loop (min)} = 20mA$ ,  $I_{loop (max)} = 30mA$ ,  $V_{sp(off)} = 3.2V_{PEAK}$ ,  $V_{spm(off)} = 0V_{PEAK}$ ,  $V_{OH(off) \text{ at Load}} = 8.34V$  the value of  $R_{SAT(off)}$  is equal to 417 $\Omega$  as calculated in Equation 4.

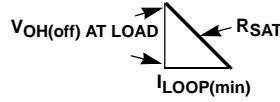

$$R_{SAT(off)} = \frac{V_{OH(off) \text{ at Load}}}{I_{LOOP(min)}} = \frac{8.34V}{20mA} = 417\Omega \quad (EQ. 4)$$

Before using this  $R_{SAT}$  value, to calculate the RDC\_RAC resistor, we need to verify that the on hook requirements will also be met.

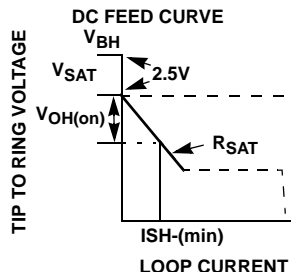

The on hook overhead voltage calculated with the off hook  $R_{SAT}$  ( $R_{SAT(off)}$ ), is given in Equation 5 and equals 3.0V. The on hook overhead calculated with Equation 1 equals 2.85V for the given system requirements

(recommended application circuit in back of data sheet): Switch Hook Detect threshold = 12mA,  $I_{SH-} = (0.6)12mA = 7.2mA$ ,  $V_{sp(on)} = 0.775V_{RMS}$

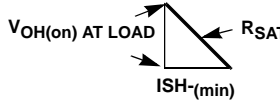

$$R_{SAT(on)} = \frac{2.85V}{7.2mA} = 395\Omega$$

Thus, the on hook overhead requirements of 2.85V will be

met if we use the  $R_{SAT(off)}$  value.

$$V_{OH(on)} = (I_{SH-})(R_{SAT(off)}) \quad (EQ. 5)$$

$$V_{OH(on)} = 7.2mA \times 417\Omega$$

$$V_{OH(on)} = 3.0V$$

If the on hook overhead requirement is not met, then we need to use the  $R_{SAT(on)}$  value to determine the RDC\_RAC resistor value. The external saturation guard resistor RDC\_RAC is equal to 50 times  $R_{SAT}$ .

In the example above  $R_{SAT}$  would equal 417 $\Omega$  and RDC\_RAC would then equal to 20.85k $\Omega$  (closest standard value is 21k $\Omega$ ).

$$RDC\_RAC = 50 \times R_{SAT} \quad (EQ. 6)$$

The Switch Hook Detect threshold current is set by resistor  $R_D$  and is calculated using Equation 7. For the above

example  $R_D$  is calculated to be 41.6k $\Omega$  (500/12mA). The next closest standard value is 41.2k $\Omega$ .

$$R_D = \frac{500}{I_{SH-}} \quad (\text{EQ. 7})$$

The true value of  $I_{SH-}$ , for the selected value of  $R_D$  is given by Equation 8:

$$I_{SH-} = \frac{500}{R_D} (0.6) \quad (\text{EQ. 8})$$

For the example above,  $I_{SH-}$  equals 7.28mA (500 x 0.6/ 41.2K). Verify that the value of  $I_{SH-}$  is above the suspected line leakage of the application. The UniSLIC family will provide a constant on hook voltage level for leakage currents up to this value of line leakage.

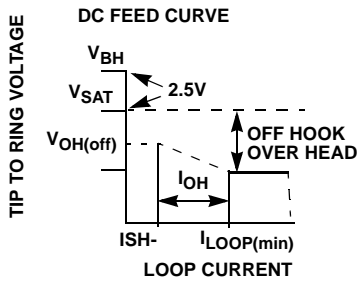

The  $R_{OH}$  resistor, which is used to set the offhook overhead voltage, is calculated using Equations 9 and 10.

$I_{OH}$  is defined as the difference between the  $I_{LOOP(min)}$  and  $I_{SH-}$ . Substituting Equation 8

for  $I_{SH-}$  into Equation 9 and solving for  $R_{OH}$  defines  $R_{OH}$  in terms of  $I_{LOOP(min)}$  and  $R_D$ .

$$R_{OH} = \frac{500}{I_{OH}} = \frac{500}{I_{LOOP(min)} - I_{SH-}} \quad (\text{EQ. 9})$$

Equation 10 can be used to determine the actual  $I_{SH-}$  value resulting from the  $R_D$  resistor selected. The value of  $R_D$  should be the next standard value that is lower than that calculated. This will insure meeting the  $I_{LOOP(min)}$  requirement.  $R_{OH}$  for the above example equals 39.1k $\Omega$ .

$$R_{OH} = \frac{R_D 500}{R_D I_{LOOP(min)} - 500(0.6)} \quad (\text{EQ. 10})$$

The current limit is set by a single resistor and is calculated using Equation 11.

$$R_{LIM} = \frac{1000}{I_{LOOP(max)}} \quad (\text{EQ. 11})$$

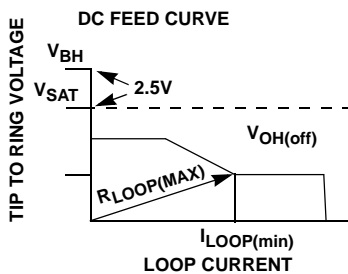

The maximum loop resistance is calculated using Equation 12. The resistance of the protection resistors ( $2R_P$ ) is subtracted out to obtain the maximum loop length to meet the required off hook

overhead voltage. If  $R_{LOOP(MAX)}$  meets the loop length requirements you are done. If the loop length needs to be longer, then consider adjusting one of the following: 1) the

$\overline{SHD}$  threshold, 2) minimum loop current requirement or 3) the on and off hook signal levels.

$$R_{LOOP(max)} = \frac{V_{BH} - [V_{SAT} + 2V + V_{OH(off)}]}{I_{LOOP(min)}} - 2R_P \quad (\text{EQ. 12})$$

### SLIC in the Active Mode

Figure 17 shows a simplified AC transmission model. Circuit analysis yields the following design equations:

$$V_A = I_M \times 2R_S \times \frac{1}{80k} \times 200(Z_{TR} - 2R_P) \times 5 \quad (\text{EQ. 13})$$

$$V_A = \frac{I_M}{2}(Z_{TR} - 2R_P) \quad (\text{EQ. 14})$$

Node Equation

$$\frac{V_{RX}}{500k} - \frac{V_A}{500k} = I_X \quad (\text{EQ. 15})$$

Substitute Equation 14 into Equation 15

$$I_X = \frac{V_{RX}}{500k} - \frac{I_M(Z_{TR} - 2R_P)}{1000k} \quad (\text{EQ. 16})$$

Loop Equation

$$I_X 500k - V_{TX}' + I_X 500k = 0 \quad (\text{EQ. 17})$$

Substitute Equation 16 into Equation 17

$$V_{TX}' = 2V_{RX} - I_M(Z_{TR} - 2R_P) \quad (\text{EQ. 18})$$

Loop Equation

$$V_{TR} - I_M 2R_P + V_{TX}' = 0 \quad (\text{EQ. 19})$$

Substitute Equation 18 into Equation 19

$$V_{TR} = I_M Z_{TR} - 2V_{RX} \quad (\text{EQ. 20})$$

Substituting  $-V_{TR}/Z_L$  into Equation 20 for  $I_M$  and rearranging to solve for  $V_{TR}$  results in Equation 21

$$V_{TR} \left( 1 + \frac{Z_{TR}}{Z_L} \right) = -2V_{RX} \quad (\text{EQ. 21})$$

where:

$V_{RX}$  = The input voltage at the VRX pin.

$V_A$  = An internal node voltage that is a function of the loop current detector and the impedance matching networks.

$I_X$  = Internal current in the SLIC that is the difference between the input receive current and the feedback current.

$I_M$  = The AC metallic current.

$R_P$  = A protection resistor (typical 30 $\Omega$ ).

$Z_T$  = An external resistor/network for matching the line impedance.

$V_{TX}'$  = The tip to ring voltage at the output pins of the SLIC.

$V_{TR}$  = The tip to ring voltage including the voltage across the protection resistors.

$Z_L$  = The line impedance.

$Z_{TR}$  = The input impedance of the SLIC including the protection resistors.

**(AC) 4-Wire to 2-Wire Gain**

The 4-wire to 2-wire gain is equal to  $V_{TR}/V_{RX}$ .

From Equation 21 and the relationship  $Z_T = 200(Z_{TR} - 2R_P)$ .

$$G_{4-2} = \frac{V_{TR}}{V_{RX}} = -2 \frac{Z_L}{Z_L + Z_{TR}} = -2 \frac{Z_L}{Z_L + \left(\frac{Z_T}{200} + 2R_P\right)} \quad (\text{EQ. 22})$$

Notice that the phase of the 4-wire to 2-wire signal is 180° out of phase with the input signal.

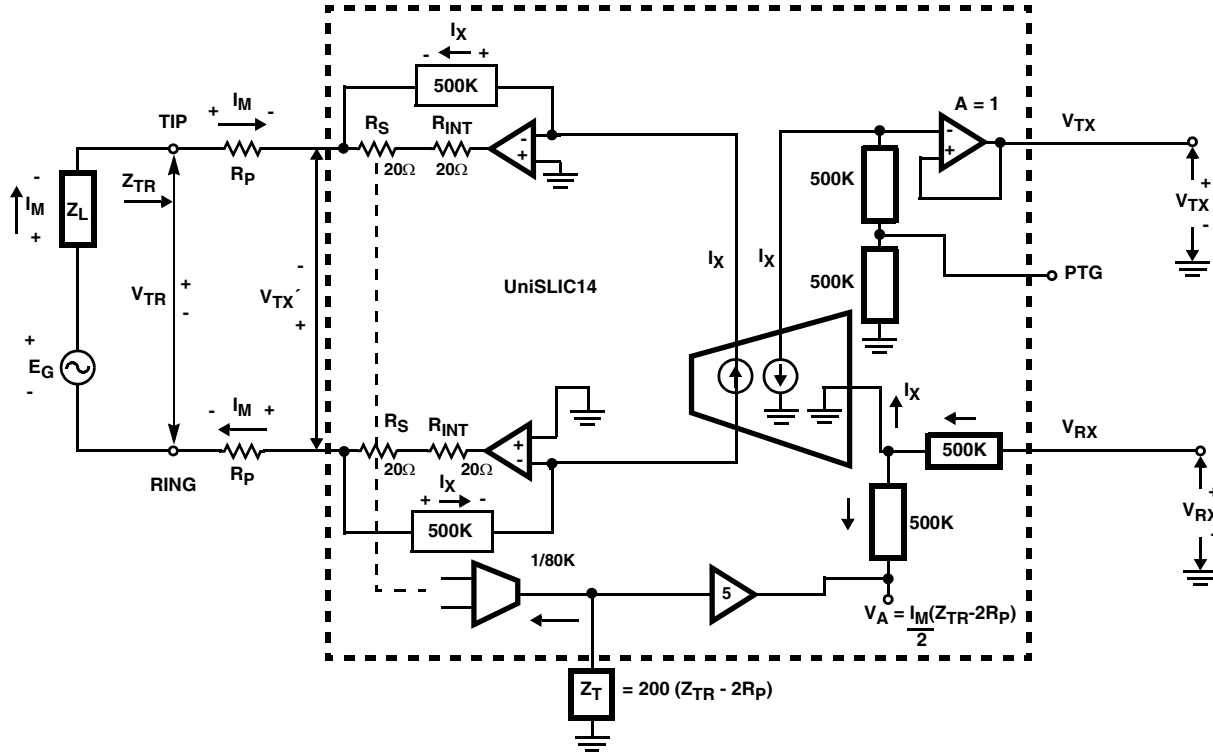

FIGURE 17. SIMPLIFIED AC TRANSMISSION CIRCUIT

**(AC) 2-Wire to 4-Wire Gain**

The 2-wire to 4-wire gain is equal to  $V_{TX}/E_G$  with  $V_{RX} = 0$

Loop Equation

$$-E_G + Z_L I_M + 2R_P I_M - V_{TX}' = 0 \quad (\text{EQ. 23})$$

From Equation 18 with  $V_{RX} = 0$

$$V_{TX}' = -I_M(Z_{TR} - 2R_P) \quad (\text{EQ. 24})$$

Substituting Equation 24 into Equation 23 and simplifying.

$$E_G = I_M(Z_L + Z_{TR}) \quad (\text{EQ. 25})$$

By design,  $V_{TX} = -V_{TX}'$ , therefore

$$G_{2-4} = \frac{V_{TX}}{E_G} = \frac{I_M(Z_{TR} - 2R_P)}{I_M(Z_L + Z_{TR})} = \frac{(Z_{TR} - 2R_P)}{(Z_L + Z_{TR})} \quad (\text{EQ. 26})$$

A more useful form of the equation is rewritten in terms of  $V_{TX}/V_{TR}$ . A voltage divider equation is written to convert from  $E_G$  to  $V_{TR}$  as shown in Equation 27.

$$V_{TR} = \left( \frac{Z_{TR}}{Z_{TR} + Z_L} \right) E_G \quad (\text{EQ. 27})$$

Rearranging Equation 27 in terms of  $E_G$ , and substituting into Equation 26 results in an equation for 2-wire to 4-wire gain, that's a function of the synthesized input impedance of the SLIC ( $Z_{TR}$ ) and the protection resistors ( $R_P$ ).

$$G_{2-4} = \frac{V_{TX}}{V_{TR}} = \frac{Z_{TR} - 2R_P}{Z_{TR}} \quad (\text{EQ. 28})$$

Notice that the phase of the 2-wire to 4-wire signal is in phase with the input signal.

**(AC) 4-Wire to 4-Wire Gain**

The 4-wire to 4-wire gain is equal to  $V_{TX}/V_{RX}$ ,  $E_G = 0$ .

From Equation 18.

$$V_{TX}' = -V_{TX} = -2V_{RX} + I_M(Z_{TR} - 2R_P) \quad (\text{EQ. 29})$$

Substituting  $-V_{TR}/Z_L$  into Equation 29 for  $I_M$  results in Equation 30.

$$V_{TX} = -2V_{RX} - \frac{V_{TR}(Z_{TR} - 2R_P)}{Z_L} \quad (\text{EQ. 30})$$

Substituting Equation 21 for  $V_{TR}$  in Equation 30 and simplifying results in Equation 31.

$$G_{4-4} = \frac{V_{TX}}{V_{RX}} = -2 \left( \frac{Z_L + 2R_P}{Z_L + Z_{TR}} \right) \quad (\text{EQ. 31})$$

**(AC) 2-Wire Impedance**

The AC 2-wire impedance ( $Z_{TR}$ ) is the impedance looking into the SLIC, including the fuse resistors. The formula to calculate the proper  $Z_T$  for matching the 2-wire impedance is shown in Equation 32.

$$Z_T = 200 \cdot (Z_{TR} - 2R_P) \quad (\text{EQ. 32})$$

Equation 32 can now be used to match the SLIC's impedance to any known line impedance ( $Z_{TR}$ ).

**EXAMPLE:**

Calculate  $Z_T$  to make  $Z_{TR} = 600\Omega$  in series with  $2.16\mu\text{F}$ .  
 $R_P = 30\Omega$ .

$$Z_T = 200 \left( 600 + \frac{1}{j\omega 2.16 \times 10^{-6}} - (2)(30) \right) \quad (\text{EQ. 33})$$

$Z_T = 108\text{k}\Omega$  in series with  $0.0108\mu\text{F}$ .

Note: Some impedance models, with a series capacitor, will cause the op-amp feedback to behave as an open circuit DC. A resistor with a value of about 10 times the reactance of the  $Z_T$  capacitor ( $2.16\mu\text{F}/200 = 10.8\text{nF}$ ) at the low frequency of interest (200Hz for example) can be placed in parallel with the capacitor in order to solve the problem ( $736\text{k}\Omega$  for a  $10.8\text{nF}$  capacitor).

**Calculating Tip and Ring Voltages**

The **on hook** tip to ground voltage is calculated using Equation 34. The minus 1.0 volt results from the SLIC self programming.  $ISH-$  is the maximum loop current for a constant on hook overhead voltage ( $ISH- = I_{SHD}(0.6)$ ) and the value of  $R_{SAT(off)}$  is calculated in Equation 4.

On hook Tip Voltage

$$V_{TIP(onhook)} = -1.0V + (ISH-) \left( \frac{R_{SAT(off)}}{2} \right) \quad (\text{EQ. 34})$$

The **off hook** tip to ground voltage is calculated using Equation 35.  $I_{LOOP(min)}$  is the minimum loop current allowed by the design and the value of  $R_{SAT(off)}$  is calculated in Equation 4.

Off hook Tip Voltage

$$V_{TIP(offhook)} = -1V - (I_{LOOP(min)}) \left( \frac{R_{SAT(off)}}{2} \right) - I_{LOOP(MAX)} \times R_P \quad (\text{EQ. 35})$$

The **on hook** ring to ground voltage is calculated using Equation 36. The 1.5 volt results from the SLIC self programming.  $ISH-$  is the maximum loop current for a

constant on hook overhead voltage ( $ISH- = I_{SHD}(0.6)$ ) and the value of  $R_{SAT(off)}$  is calculated in Equation 4.

On hook Ring Voltage

$$V_{RING(onhook)} = V_{BH} + 1.5V + (ISH-) \left( \frac{R_{SAT(off)}}{2} \right) \quad (\text{EQ. 36})$$

The calculation of the ring voltage with respect to ground in the off hook condition is dependent upon whether the SLIC is in current limit or not.

The **off hook** ring to ground voltage (in current limit) is calculated using Equation 37.  $I_{LIM}$  is the programmed loop current limit and  $R_L$  is the load resistance across tip and ring. The minus 0.2V is a correction factor for the  $60\text{k}\Omega$  slope in Figure 15.

Off hook Ring Voltage in Current Limit

$$V_{RING(CL)} = V_{TIP(offhook)} - I_{LOOP(MAX)} R_L - 0.2V \quad (\text{EQ. 37})$$

The **off hook** ring to ground voltage (not in current limit) is calculated using Equation 38. The 1.5V results from the SLIC self programming.  $I_{LOOP(min)}$  is the minimum loop current allowed by the design and the value of  $R_{SAT(off)}$  is calculated in Equation 4.

Off hook Ring Voltage not in Current Limit

$$V_{RING(NCL)} = V_{BH} + 1.5V + (I_{LOOP(min)}) \left( \frac{R_{SAT(off)}}{2} \right) - I_{LOOP(MIN)} \times R_P \quad (\text{EQ. 38})$$

**Layout Considerations**

**Systems with Dual Supplies ( $V_{BH}$  and  $V_{BL}$ )**

If the  $V_{BL}$  supply is **not** derived from the  $V_{BH}$  supply, it is recommended that an additional diode be placed in series with the  $V_{BH}$  supply. The orientation of this diode is anode on pin 8 of the device and cathode to the external supply. This external diode will inhibit large currents and potential damage to the SLIC, in the event the  $V_{BH}$  supply is shorted to GND. If  $V_{BL}$  is derived from  $V_{BH}$  then this diode is not required. Suggested (not required) supply sequence  $V_{BH} - V_{BL} - V_{CC}$ .

**Floating the PTG Pin**

The PTG pin is a high impedance pin ( $500\text{k}\Omega$ ) that is used to program the 2-wire to 4-wire gain to either 0dB or -6dB.

If 0dB is required, it is necessary to float the PTG pin. The PC board interconnect should be as short as possible to minimize stray capacitance on this pin. Stray capacitance on this pin forms a low pass filter and will cause the 2-wire to 4-wire gain to roll off at the higher frequencies.

If a 2-wire to 4-wire gain of -6dB is required, the PTG pin should be grounded as close to the device as possible.

**SPM Pin**

For optimum performance, the PC board interconnect the SPM pin should be as short as possible. If pulses metering is not being used, then this pin should be grounded as close to the device pin as possible.

**RLIM Pin**











The current limiting resistor  $R_{LIM}$  needs to be as close to the RLIM pin as possible.

**Layout of the 2-Wire Impedance Matching Resistor  $Z_T$**

Proper connection to the ZT pin is to have the external  $Z_T$  network as close to the device pin as possible.

The ZT pin is a high impedance pin that is used to set the proper feedback for matching the impedance of the 2-wire side. This will eliminate circuit board capacitance on this pin to maintain the 2-wire return loss across frequency.

TABLE 1. DETECTOR STATES

STATE	C3	C2	C1	SLIC OPERATING STATE	ACTIVE DETECTOR	OUTPUT	
						SHD	GKD_LVM
0	0	0	0	Open Circuit State	4 wire loopback test capability	HIGH	HIGH
1	0	0	1	Ringing State (Previous State cannot be Reverse Active State)	Ring Trip Detector		HIGH
2	0	1	0	Forward Active State	Loop Current Detector		
					Ground Key Detector		
3	0	1	1	Test Active State Requires previous state to be in the Forward Active state to determine the On hook or Off hook status of the line.	On Hook Loopback Detector	LOW	
					Ground Key Detector		HIGH
					Off Hook Loop Current Detector	LOW	
					Line Voltage Detector		
4	1	0	0	Tip Open - Ground Start State	Ground Key Detector		
5	1	0	1	Reserved	Reserved	N/A	N/A
6	1	1	0	Reverse Active State	Loop Current Detector		
					Ground Key Detector		
7	1	1	1	Test Reversal Active State Requires previous state to be in the Reverse Active state to determine the On hook or Off hook status of the line.	On Hook Loop Current Detector		HIGH
					Off Hook Loop Current Detector	LOW	
					Line Voltage Detector		
8	X	X	X	Thermal Shutdown		LOW	LOW

**Digital Logic Inputs**

Table 1 is the logic truth table for the 3V to 5V logic input pins. A combination of the control pins C3, C2 and C1 select 1 of the possible 6 operating states. The 8th state listed is Thermal Shutdown. Thermal Shutdown protection is invoked if a fault condition on the tip or ring causes the junction temperature of the die to exceed 175°C. A description of each operating state and the control logic follows:

**Open Circuit State (C3 = 0, C2 = 0, C1 = 0)**

In this state, the tip and ring outputs are in a high impedance condition ( $>1M\Omega$ ). No supervisory functions are available and SHD and GKD outputs are at a TTL high level.

4-wire loopback testing can be performed in this state. With the PTG pin floating, the signal on the  $V_{TX}$  output is 180° out of phase and approximately 2 times the  $V_{RX}$  input signal. If

the PTG pin is grounded, then the amplitude will be approximately the same as its input and 180° out of phase.

**Ringing State (C3 = 0, C2 = 0, C1 = 1)**

In this state, the output of the ring relay driver pin (RRLY) goes low (energizing the ring relay to connect the ringing signal to the phone) if either of the following two conditions are satisfied:

**(1) The RSYNC\_REV pin is grounded through a resistor -**

This connection enables the RRLY pin to go low the instant the ringing state is invoked, without any regard for the ringing voltage ( $90V_{RMS}$  -  $120V_{RMS}$ ) across the relay contacts. The resistor ( $34.8k\Omega$  to  $70k\Omega$ ) is required to limit the current into the RSYNC\_REV pin.

**(2) A ring sync pulse is applied to the RSYNC\_REV pin -**

This connection enables the RRLY pin to go low at the command of a ring sync pulse. A ring sync pulse should go

low at zero **voltage** crossing of the ring signal. This pulse should have a rise and fall time <400µs and a minimum pulse width of 2ms.

Zero ring **current** detection is performed automatically inside the SLIC. This feature de-energizes the ring relay slightly before zero current occurs to partially compensate for the delay in the opening of the relay.

The  $\overline{\text{SHD}}$  output will go low when the subscriber goes off hook. Once  $\overline{\text{SHD}}$  is activated, an internal latch will prohibit the re-ringing of the line until the ringing code is removed and then reapplied.

The state prior to ringing the phone, can not be the Reverse Active State. In the reverse active state the polarity of the voltage on the CRT\_REV\_LVM capacitor, will make it appear as if the subscriber is off hook. This subsequently will activate an internal latch prohibiting the ringing of the line.

The  $\overline{\text{GKD\_LVM}}$  output is disabled (TTL high level) during the ringing state. Reference the Section titled "Ringing the Phone" for more information.

**Forward Active State (C3 = 0, C2 = 1, C1 = 0)**

In this state, the SLIC is fully functional. The tip voltage is more positive than the ring voltage. The tip and ring output voltages are an unbalanced DC feed, reference Figure 13. Both  $\overline{\text{SHD}}$  and  $\overline{\text{GKD}}$  supervisory functions are active. Reference the section titled "DC Feed Curve" for more information.

**Test Active State (C3 = 0, C2 = 1, C1 = 1)**

Proper operation of the Test Active State requires the previous state be the Forward Active state to determine the on hook or off hook status of the line. In this state, the SLIC can perform two different tests.

If the subscriber is **on hook** when the state is entered, a loopback test is performed by switching an internal 600Ω resistor between tip and ring. The current flows through the internal 600Ω is unidirectional via blocking diodes. (Cannot be used in reverse.) When the loopback current flows, the  $\overline{\text{SHD}}$  output will go low and remain there until the state is exited. This is intended to be a short test since the ability to detect subscriber off hook is lost during loopback testing. Reference the section titled "Loopback Tests" for more information.

If the subscriber is **off hook** when the state is entered, a Line Voltage Measurement test is performed. The output of the  $\overline{\text{GKD\_LVM}}$  pin is a pulse train. The pulse width of the active low portion of the signal is proportional to the voltage across the tip and ring pins. If the loop length is such that the SLIC is operating in constant current, the tip to ring voltage can be used to determine the length of the line under test. The longer the line, the larger the tip to ring voltage and the wider the pulse. This relationship can determine the length of the line for setting gains in the system. Reference the section titled "Operation of Line Voltage Measurement" for more information.

**Tip Open State (C3 = 1, C2 = 0, C1 = 0)**

In this state, the tip output is in a high impedance state (>250kΩ) and the ring output is capable of full operation, i.e. has full longitudinal current capability. The Tip Open/Ground Start state is used to interface to a PBX incoming 2-wire trunk line. When a ground is applied through a resistor to the ring lead, this current is detected and presented as a TTL logic low on the  $\overline{\text{SHD}}$  and  $\overline{\text{GKD\_LVM}}$  output pins.

**Reserved (C3 = 1, C2 = 0, C1 = 1)**

This state is undefined and reserved for future use.

**Reverse Active State (C3 = 1, C2 = 1, C1 = 0)**

In this state, the SLIC is fully functional. The ring voltage is more positive than the tip voltage. The tip and ring output voltages are an unbalanced DC feed, reference Figure 13. The polarity reversal time is determined by the RC time constant of the RSYNC\_REV resistor and the CRT\_REV\_LVM capacitor. Capacitor CRT\_REV\_LVM performs three different functions: Ring trip filtering, polarity reversal time and line voltage measurement. It is recommended that programming of the reversal time be accomplished by changing the value of RSYNC\_REV resistor (see Figure 18). The value of RSYNC\_REV resistor is limited between 34.8K (10ms) and 73.2k (21ms). Equation 39 gives the formula for programming the reversal time.

$$\text{RSYNC\_REV} = 3.47\text{k}\Omega \times \text{ReversalTime(ms)} \quad (\text{EQ. 39})$$

Both  $\overline{\text{SHD}}$  and  $\overline{\text{GKD}}$  supervisory functions are active. Reference the section titled "Polarity Reversal" for more information.

**Test Reversal Active State (C3 = 1, C2 = 1, C1 = 1)**

Proper operation of the Test Reversal Active State requires the previous state be the Reverse Active state to determine the on hook or off hook status of the line.

If the subscriber is **on hook** when the state is entered, the SLIC's tip and ring voltages are the same as the Reverse Active state. The  $\overline{\text{SHD}}$  output will go low when the subscriber goes off hook and the  $\overline{\text{GKD\_LVM}}$  output is disabled (TTL level high). (Note: operation is the same as the Reverse Active state with the  $\overline{\text{GKD\_LVM}}$  output disabled.)

If the subscriber is **off hook** when the state is entered, a Line Voltage Measurement test is performed.

The output of the  $\overline{\text{GKD\_LVM}}$  pin is a pulse train. The pulse width of the active low portion of the signal is proportional to the voltage across the tip and ring pins. If the loop length is such that the SLIC is operating in constant current mode, the tip to ring voltage can be used to determine the length of the line under test. The longer the line, the larger the tip to ring voltage and the wider the pulse. This relationship can determine the length of the line for setting gains in the system. Reference the section titled "Operation of Line Voltage Measurement" for more information.

### Thermal Shutdown

The UniSLIC14's thermal shutdown protection is invoked if a fault condition causes the junction temperature of the die to exceed about 175°C. Once the thermal limit is exceeded, both detector outputs go low ( $\overline{\text{SHD}}$  and  $\overline{\text{GKD\_LVM}}$ ) and one of two things can happen.

For marginal faults where loop current is flowing during the time of the over-temperature condition, foldback loop current limiting reduces the loop current by reducing the tip to ring voltage. An equilibrium condition will exist that maintains the junction temperature at about 175°C until the fault condition is removed.

For short circuit faults (tip or ring to ground, or to a supply, etc.) that result in an over-temperature condition, the foldback current limiting will try to maintain an equilibrium at about 175°C. If the junction temperature keeps rising, the device will thermally shutdown and disconnect tip and ring until the junction temperature falls to approximately 150°C.

### Supervisory Functions

#### Switch Hook Detect Threshold

The Switch Hook Detect Threshold is programmed with a single external resistor ( $R_D$ ). The output of the  $\overline{\text{SHD}}$  pin goes low when an off hook condition is detected.

#### Ground Key Detect Threshold

The Ground Key Detect Threshold is set internally and is not user programmable.

### Ringing the Phone

The UniSLIC14 family handles all the popular ringing formats with high or low side ring trip detection. High side detection is possible because of the high common mode range on the ring signal detect input pins (DT, DR). To minimize power drain from the ring generator, when the phone is not being rung, the sense resistors are typically 2M $\Omega$ . This reduces the current draw from the ring generator to just a few microamps.

When the subscriber goes off hook during ringing, the UniSLIC14 family automatically releases the ring relay and DC feed is applied to the loop. The UniSLIC14 family has very low power dissipation in the on hook active mode. This enables the SLIC (during the ring cadence) to be powered up in the active state, avoiding unnecessary powering up and down of the SLIC. The control logic is designed to facilitate easy implementation of the ring cadence, requiring only one bit change to go from active to ringing and back again.

#### DT, DR AND RRLY INPUTS

Ring trip detection will occur when the DR pin goes more positive than DT by approximately 4V.

The ring relay driver pin, RRLY, has an internal clamp between its output and ground. This eliminates the need to place an external snubber diode across the ring relay.

### Reducing Impulse Noise During Ringing

With an increase in digital data lines being installed next to analog lines, the threat from impulse noise on analog lines is increasing. Impulse noise can cause large blocks of high speed data to be lost, defeating most error correcting techniques. The UniSLIC14 family has the capability to reduce impulse noise by closing the ring relay at zero voltage and opening the ring relay at zero current.

#### CLOSING THE RING RELAY AT ZERO VOLTAGE

Closing the ring relay at zero voltage is accomplished by providing a ring sync pulse to the RSYNC\_REV pin. The ring sync pulse is synchronized to go low at the zero voltage crossing of the ring signal. The resistor R1 in Figure 18 limits the current into the RSYNC\_REV pin. If a particular polarity reversal time is required, then make R1 equal to the calculated value in Equation 39. If a specific polarity reversal time is not desired, R1 equal to 50k $\Omega$  is suggested.

The RSYNC\_REV pin is designed to allow the ring sync pulse to be present at all times. There is no need to gate the ring sync pulse on and off. The logic control for the RSYNC\_REV pin **cannot** be an open collector. It must be high (push-pull logic output stage / pull up resistor to VCC), low or being clocked by the ring sync pulse. When the RSYNC\_REV pin is high the ring relay pin is disabled. When the RSYNC\_REV pin is low the ring relay pin is activated the instant the logic code for ringing is applied.

#### OPENING THE RING RELAY AT ZERO CURRENT

The ring relay is automatically opened at zero current by the SLIC. The SLIC logic requires zero ringing current in the loop and either a valid switch hook detect ( $\overline{\text{SHD}}$ ) or a change in the operating mode (cadence of the ringing signal) to release the ring relay.

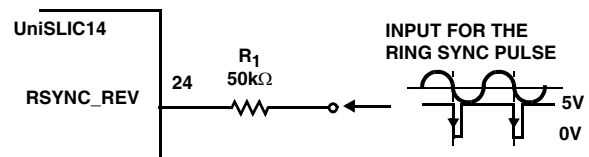

FIGURE 18. REDUCING IMPULSE NOISE USING THE RSYNC\_REV PIN AND SETTING THE POLARITY REVERSAL TIME

If the subscriber goes off hook during ringing, the  $\overline{\text{SHD}}$  output will go low. An internal latch will sense  $\overline{\text{SHD}}$  is low and disable the ring relay at zero ringing current. This prevents the ring signal from being reapplied to the line. To ring the line again, the SLIC must toggle between logic states. (Note: The previous state can not be the Reverse Active State. In the reverse state, the voltage on the CRT\_REV\_LVM

capacitor will activate an internal latch prohibiting the ringing of the line.

Figure 19 shows the sequence of events from ringing the phone to ring trip. The ring relay turns on when both the ringing code and ring sync pulse are present (A).  $\overline{\text{SHD}}$  is high at this point. When the subscriber goes off hook the  $\overline{\text{SHD}}$  pin goes low and stays low until the ringing control code is removed (B). This prevents the  $\overline{\text{SHD}}$  output from pulsing after ring trip occurs. At the next zero current crossing of the ring signal, ring trip occurs and the ring relay releases the line to allow loop current to flow in the loop (C).

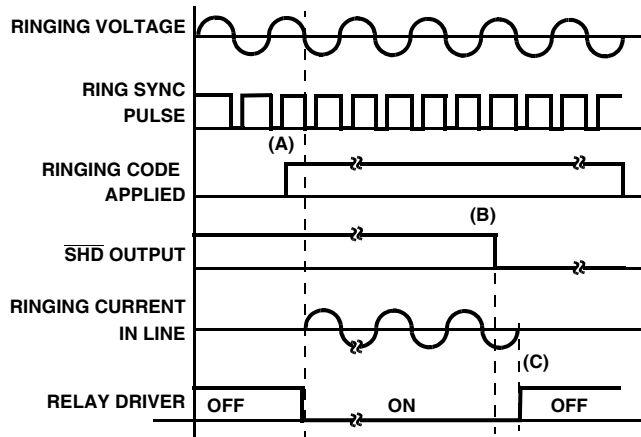

FIGURE 19. RINGING SEQUENCE

### Operation of Line Voltage Measurement

A few of the SLICs in the UniSLIC14 family feature Line Voltage Measurement (LVM) capability. This feature provides a pulse on the  $\overline{\text{GKD\_LVM}}$  output pin that is proportional to the loop voltage. Knowing the loop voltage and thus the loop length, other basic cable characteristics such as attenuation and capacitance can be inferred. Decisions can be made about gain switching in the CODEC to overcome line losses and verification of the 2-wire circuit integrity.

The LVM function can only be activated in the off hook condition in either the forward or reverse operating states. The LVM uses the ring signal supplied to the SLIC as a timebase generator. The loop resistance is determined by monitoring the pulse width of the output signal on the  $\overline{\text{GKD\_LVM}}$  pin. The output signal on the  $\overline{\text{GKD\_LVM}}$  pin is a square wave for which the average duration of the low state is proportional to the average voltage between the tip and ring terminals. The loop resistance is determined by the tip to ring voltage and the constant loop current. Reference Figure 20.

Although the logic state changes to the Test Active State when performing this test, the SLIC is still powered up in the

active state (forward or reverse) and the subscriber is unaware the measurement is being taken.

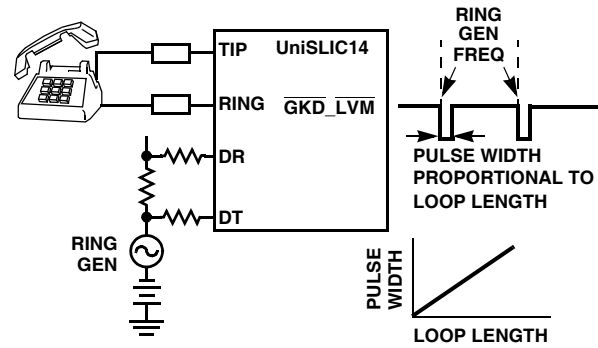

FIGURE 20. OPERATION OF THE LINE VOLTAGE MEASUREMENT CIRCUIT

### Polarity Reversal

Most of the SLICs in the UniSLIC14 family feature full polarity reversal. Full polarity reversal means that the SLIC can: transmit, determine the status of the line (on hook and off hook) and provide “silent” polarity reversal. The value of  $\text{RSYNC\_REV}$  resistor is limited between 34.8k (10ms) and 73.2k (21ms). Reference Equation 39 to program the polarity reversal time.

### Transhybrid Balance

If a low cost CODEC is chosen that does not have a transmit op-amp, the UniSLIC14 family of SLICs can solve this problem without the need for an additional op-amp. The solution is to use the Programmable Transmit Gain pin (PTG) as an input for the receive signal ( $V_{RX}$ ). In theory, when the PTG pin is connected to a divider network (R1 and R2 Figure 21) and the value of R1 and R2 is much less than the internal 500k $\Omega$  resistors, two things happen. First the transmit gain from  $V_{RX}$  to  $V_{TX}$  is reduced by half. This is the result of shorting out the bottom 500k $\Omega$  resistor with the much smaller external resistor. And second, the input signal from  $V_{RX}$  is also decreased by the voltage divider R1 and R2. Transhybrid balance occurs when these two, equal but opposite in phase, signals are cancelled at the input to the output buffer. The calculation of the value of R2, once R1 is selected, is effected by the line feed resistors. EQ. 40 can be used to calculate the value of R2. Where:  $Z_L$  = Line Impedance,  $Z_{TR}$  = input impedance of SLIC including the protection resistor, and  $R_P$  = protection resistors (typical 30 $\Omega$ ).

$$R_2 = \frac{R_1 11500K}{1.02} \left( \frac{Z_L + Z_{TR}}{Z_L + 2ZR_P} \right) - \frac{R_1 11500K}{1.02} \quad (\text{EQ. 40})$$

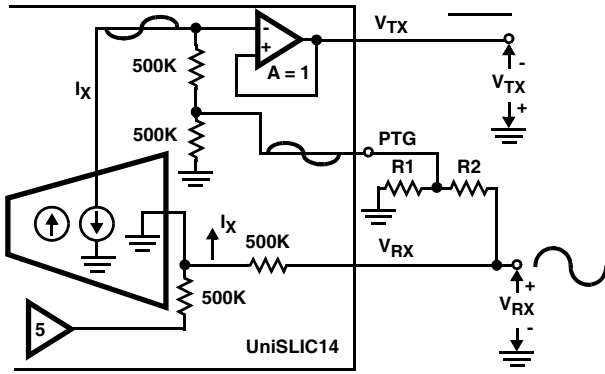

FIGURE 21. TRANSHYBRID BALANCE USING THE PTG PIN

## Loopback Tests

### 4-Wire Loopback Test

This feature can be very useful in the testing of line cards during the manufacturing process and in field use. The test is unobtrusive, allowing it to be used in live systems. Reference Figure 22.

Most systems do not provide 4-wire loopback test capability because of costly relays needed to switch in external loads. All the SLICs in the UniSLIC14 family can easily provide this function when configured in the Open Circuit logic state. With the PTG pin floating, the signal on the V<sub>TX</sub> output is 180° out of phase and approximately 2 times the V<sub>RX</sub> input signal. If the PTG pin is grounded, then the amplitude will be approximately the same as the input signal and 180° out of phase.

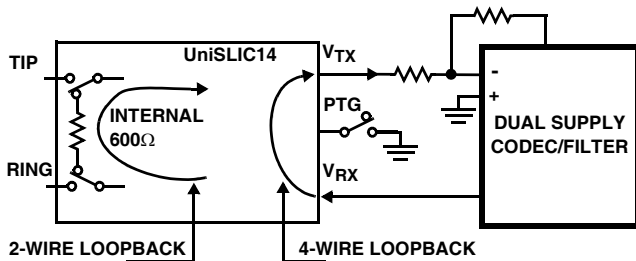

FIGURE 22. 4-WIRE AND 2-WIRE LOOPBACK TESTS

### 2-Wire Loopback Test

Most of the SLICs in the UniSLIC14 family feature 2-Wire loopback testing. This loopback function is only activated when the subscriber is **on hook** and the logic command to the SLIC is in the Test Active State. (Note: if the subscriber is **off hook** and in the Test Active State, the function performed is the Line Voltage Measurement.)

During the 2-wire loopback test, a 2kΩ internal resistor is switched across the tip and ring terminals of the SLIC. This allows the SHD function and the 4-wire to 4-wire AC transmission, right up to the subscriber loop, to be tested. Together with the 4-wire loopback test in the Open Circuit logic state, this 2-wire loopback test allows the complete

network (including SLIC) to be tested up to the subscriber loop.

## Pulse Metering

The HC55121, HC55142, HC55143, and HC55150 are designed to support pulse metering. They offer solutions to the following pulse metering design issues:

- 1) Providing adequate signal gain and current drive to the subscriber metering equipment to overcome the attenuation of this (12kHz, 16kHz) out of band signal.
- 2) Attenuating the pulse metering transhybrid signal without severely attenuating the voice band signal to avoid clipping in the CODEC/Filter.
- 3) Tailoring the overload levels in the SLIC to avoid clipping of the combined voiceband and pulse metering signal.
- 4) Having the provision of silent polarity reversal as a backup in the case where the loop attenuates the out of band signal too much for it to be detected by the subscriber's metering equipment.

## Adequate Signal Gain

Adequate signal gain and current drive to the subscriber's metering equipment is made easier by the network shown in Figure 23. The pulse metering signal is supplied to a dedicated high impedance input pin called SPM. The circuit in Figure 23 shows the connection of a network that sets the 2-wire impedance ( $Z_{TR}$ ), at the pulse metering frequencies, to be approximately 200Ω. If the line impedance ( $Z_L$ ) is equal to 200Ω at the pulse metering frequencies, then the 4-Wire to 2-wire gain ( $V_{TR}/SPM$ ) is equal 4. Thereby lowering the input signal requirements of the pulse metering signal.

Note: The automatic pulse metering 2-wire impedance matching is independent of the programmed 2-wire impedance matching at voiceband frequencies.

Calculation of the pulse metering gain is achieved by replacing  $V_{RX}/500k$  in Equation 15 with  $SPM/125k$  and following the same process through to Equation 21. The UniSLIC14 sets the 2-wire input impedance of the SLIC ( $Z_{TR}$ ), including the protection resistors, equal to 200Ω. The results are shown in Equation 41.

$$A_{4-2} = \frac{V_{TR}}{SPM} = -8 \frac{Z_L}{Z_L + Z_{TR}} = -8 \frac{200}{200 + 200} = -4 \quad (\text{EQ. 41})$$

## Avoiding Clipping in the CODEC/Filter

The amplitude of the returning pulse metering signal is often very large and could easily over drive the input to the CODEC/Filter. By using the same method discussed in section "Transhybrid Balance", most if not all of the pulse metering signal can be canceled out before it reaches the input to the CODEC/Filter. This connection is shown in Figure 23.

**Overload Levels and Silent Polarity Reversal**

The pulse metering signal and voice are simultaneously transmitted, and therefore require additional overhead to prevent distortion of the signal. Reference section “Off hook Overhead Voltage” to account for the additional pulse metering signal requirements.

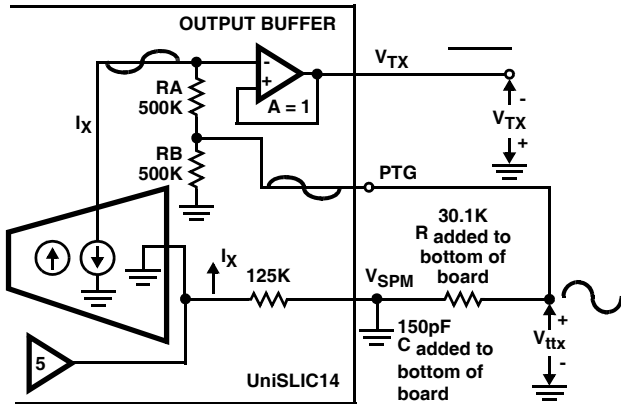

FIGURE 23. PULSE METERING WITH TRANSHYBRID BALANCE

Most of the SLICs in the UniSLIC14 family feature full polarity reversal. Full polarity reversal means that the SLIC can transmit, determine the status of the line (on hook and off hook) and provide “silent” polarity reversal. Reference Equation 39 to program the polarity reversal time.

**Interface to Dual and Single Supply CODECs**

Great care has been taken to minimize the number of external components required with the UniSLIC14 family while still providing the maximum flexibility. Figures 24A, 24B) shows the connection of the UniSLIC14 to both a dual supply CODEC/Filter and a single supply DSP CODEC/Filter.

To eliminate the DC blocking capacitors between the SLIC and the CODEC/Filter when using a dual supply CODEC/Filter, both the receive and transmit leads of the SLIC are referenced to ground. This leads to a very simple SLIC to CODEC/Filter interface, as shown in Figure 24A.

When using a single supply DSP CODEC/Filter the output and input of the CODEC/Filter are no longer referenced to ground. To achieve maximum voltage swing with a single supply, both the output and input of the CODEC/Filter are referenced to its own  $V_{CC}/2$  reference. Thus, DC blocking capacitors are once again required. By using the PTG pin of the UniSLIC14 and the externally supplied  $V_{CC}/2$  reference

of the CODEC/Filter, one of the DC blocking capacitors can be eliminated (Figure 24B).

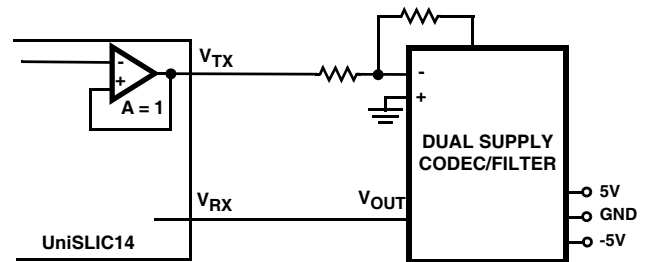

FIGURE 24A.

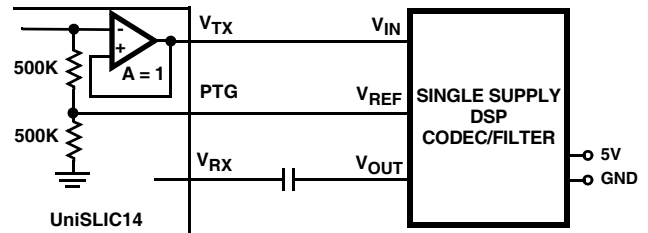

FIGURE 24B.

FIGURE 24. INTERFACE TO DUAL AND SINGLE SUPPLY CODECs

**Power Management**

The UniSLIC14 family provides two distinct power management capabilities:

**Power Sharing and Battery Selection**

**Power Sharing**

Power sharing is a method of redistributing the power away from the SLIC in short loop applications. The total system power is the same, but the die temperature of the SLIC is much lower. Power sharing becomes important if the application has a single battery supply (-48V on hook requirements for faxes and modems) and the possibility of high loop currents (reference Figure 25). This technique would prevent the SLIC from getting too hot and thermally shutting down on short loops.

The power dissipation in the SLIC is the sum of the smaller quiescent supply power and the much larger power that results from the loop current. The power that results from the loop current is the loop current times the voltage across the SLIC. The power sharing resistor ( $R_{PS}$ ) reduces the voltage across the SLIC, and thereby the on-chip power dissipation. The voltage across the SLIC is reduced by the voltage drop across  $R_{PS}$ . This occurs because  $R_{PS}$  is in series with the loop current and the negative supply.

A mathematical verification follows:

Given:  $V_{BH} = V_{BL} = -48V$ , Loop current = 30mA,  $R_L$  (load across tip and ring) = 600Ω, Quiescent battery power = (48V)(0.8mA) = 38.4mW, Quiescent  $V_{CC}$  power = (5V)(2.7mA) = 13.5mW, Power sharing resistor = 600Ω.

1. Without power sharing, the on-chip power dissipation would be 952mW (Equation 42).
2. With power sharing, the on-chip power dissipation is 412mW (Equation 43). A power redistribution of 540mW.

On-chip power dissipation without power sharing resistor.

$$PD = (V_{BH})(30mA) + 38.4mW + 13.5mW - (R_L)(30mA)^2$$

$$PD = 952mW \quad (EQ. 42)$$

On-chip power dissipation with 600Ω power sharing resistor.

$$PD = (V_{BH})(30mA) + 38.4mW + 13.5mW - (R_L)(30mA)^2 - (R_{PS})(30mA)^2$$

$$PD = 412mW \quad (EQ. 43)$$

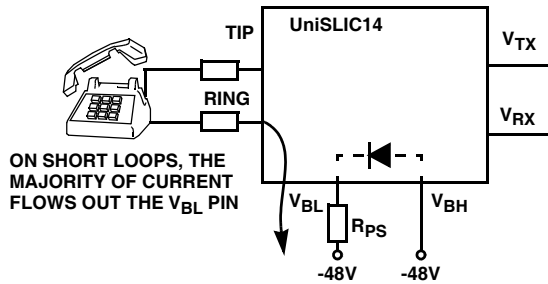

FIGURE 25. POWER SHARING (SINGLE SUPPLY SYSTEMS)

### Battery Selection

Battery selection is a technique, for a two battery supply system, where the SLIC automatically diverts the loop current to the most appropriate supply for a given loop length. This results in significant power savings and lowers the total power consumption on short loops. This technique is particularly useful if most of the lines are short, and the on hook condition requires a -48V battery. In Figure 26, it can be seen that for long loops the majority of the current comes from the high battery supply ( $V_{BH}$ ) and for short loops from the low battery supply ( $V_{BL}$ ).

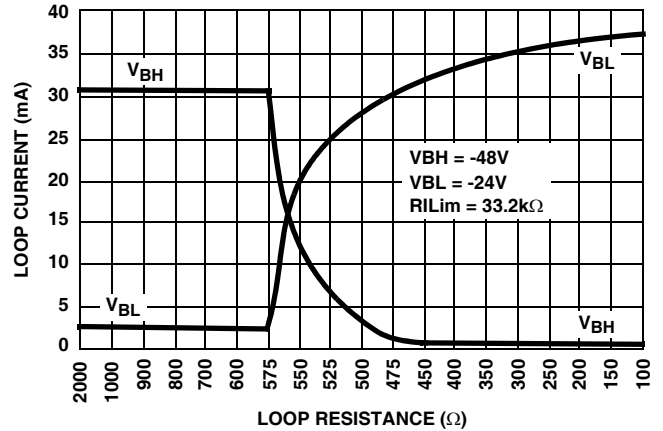
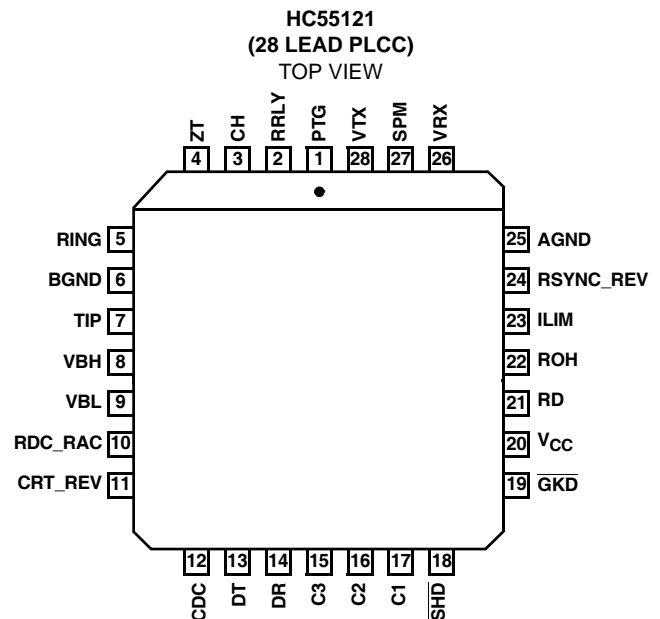
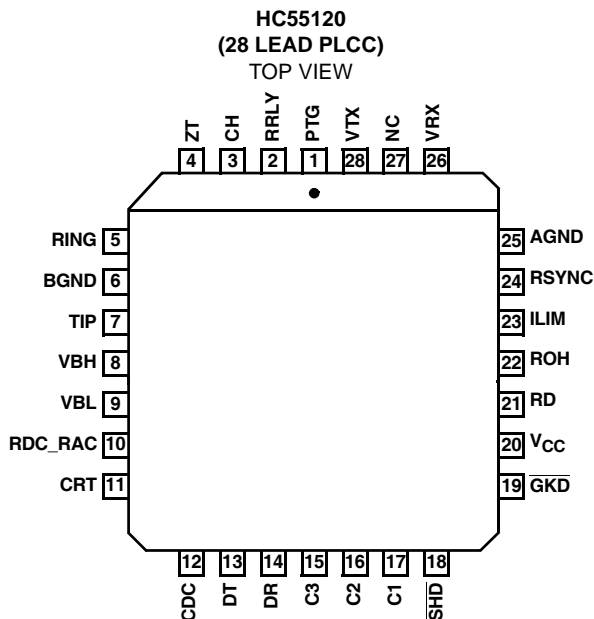

FIGURE 26. BATTERY SELECTION (DUAL SUPPLY SYSTEMS)

### Pinouts - 28 Lead PLCC Packages



Pinouts - 28 Lead PLCC Packages (Continued)

HC55130  
(28 LEAD PLCC)  
TOP VIEW

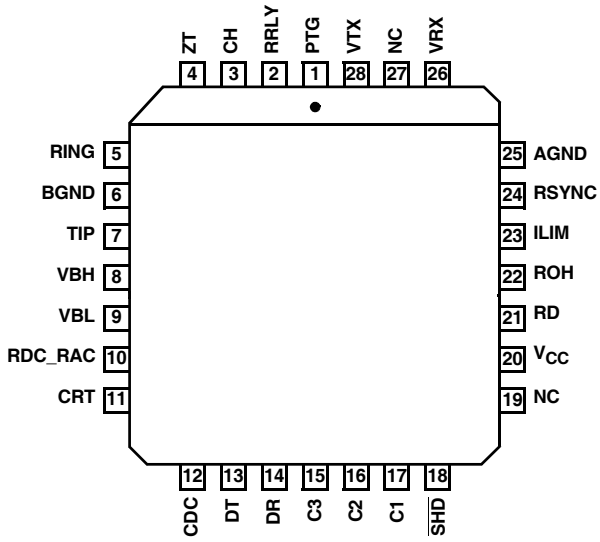

HC55140  
(28 LEAD PLCC)  
TOP VIEW

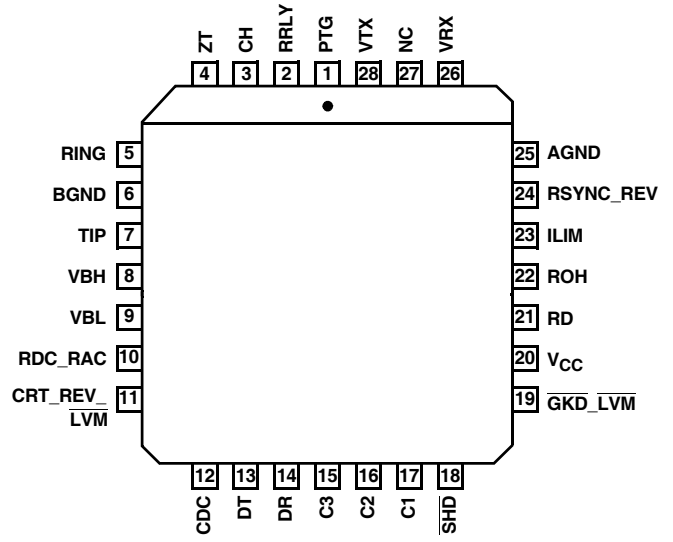

HC55142  
(28 LEAD PLCC)  
TOP VIEW

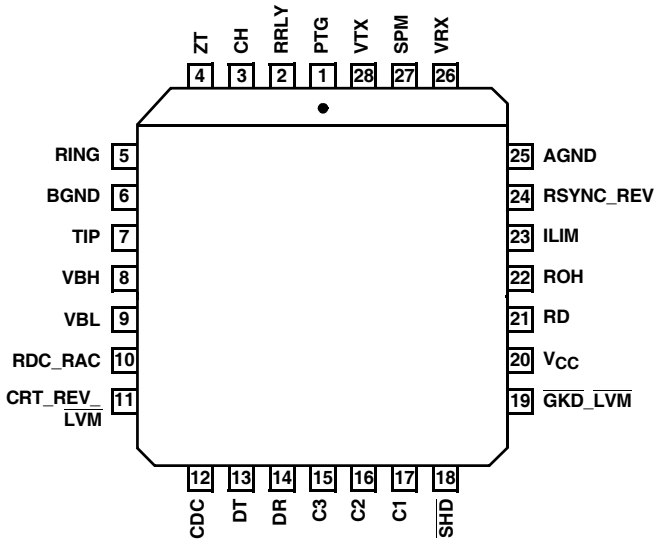

HC55150  
(28 LEAD PLCC)  
TOP VIEW

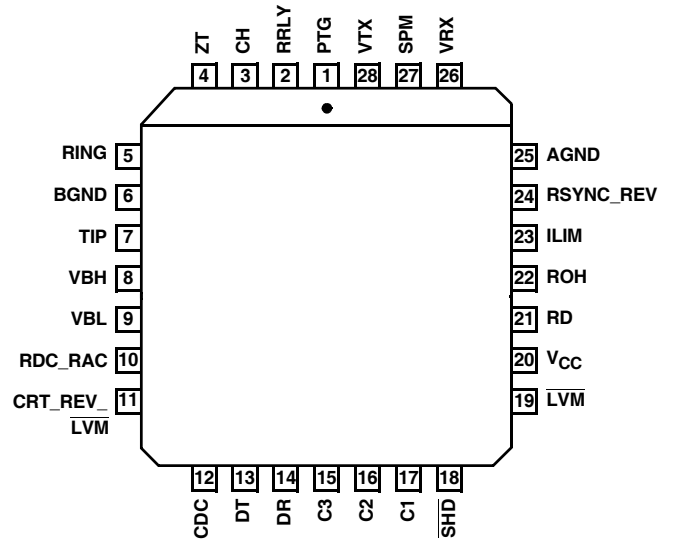

**Pinouts - 32 Lead PLCC Packages**

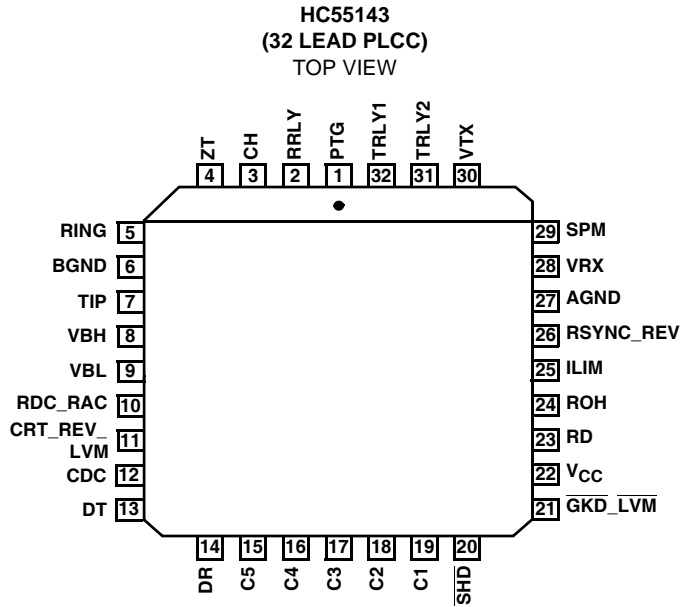

**Pinouts - 28 Lead SOIC Packages**

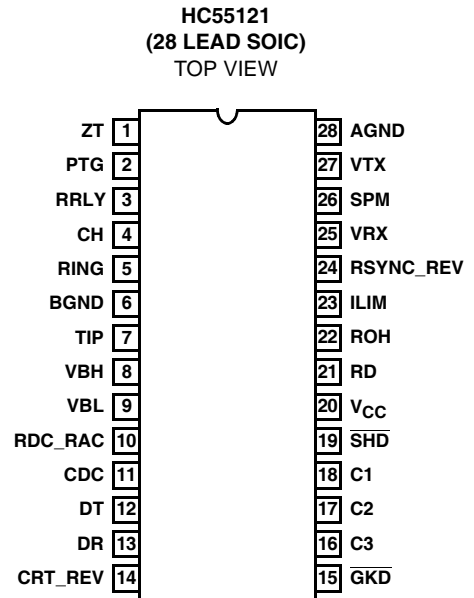
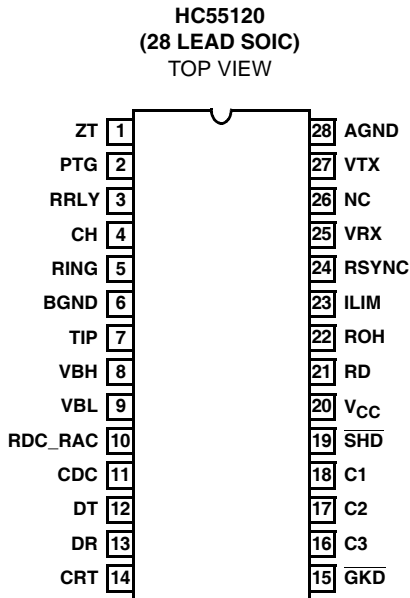

Pinouts - 28 Lead SOIC Packages (Continued)

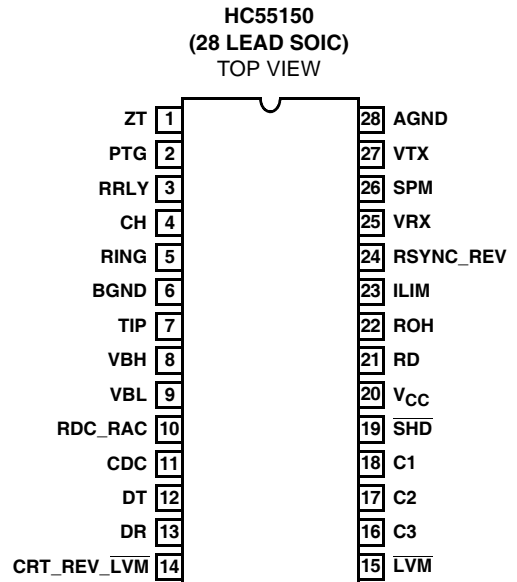
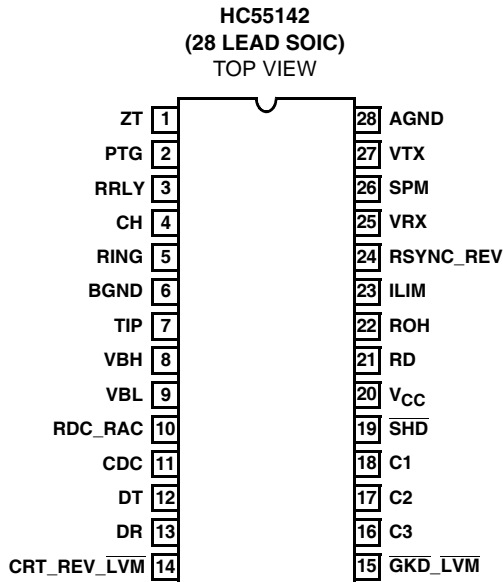
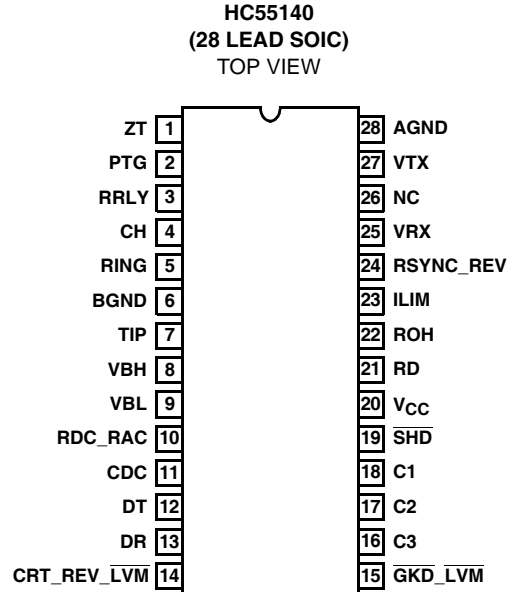
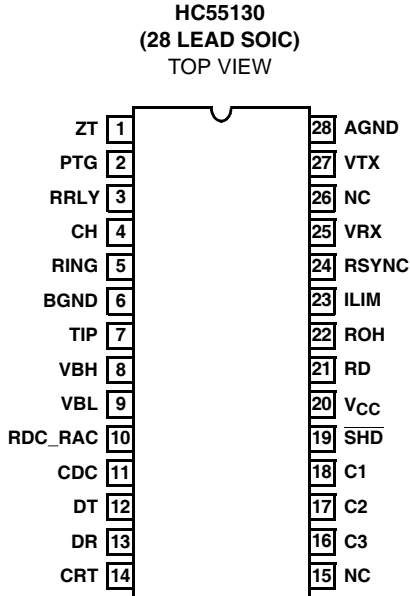

Pin Descriptions

28 PIN PLCC	32 PIN PLCC	28 PIN SOIC	SYMBOL	DESCRIPTION
1	1	2	PTG	Programmable Transmit Gain - The 2-wire to 4-wire transmission gain is 0dB if this pin is left floating and -6.02dB if tied to ground. The -6.02dB gain option is useful in systems where Pulse Metering is used. See Figure 23.
2	2	3	RRLY	Ring Relay Driver Output - The relay coil may be connected to a maximum of 14V.
3	3	4	CH	AC/DC Separation Capacitor - CH is required to properly process the AC current from the DC loop current. Recommended value 0.1µF.
4	4	1	ZT	2-Wire Impedance Matching Pin - Impedance matching of the 2-wire side is accomplished by placing an impedance between the ZT pin and ground. See Equation 32.
5	5	5	RING	Connects via protection resistor R <sub>P</sub> to ring wire of subscriber pair.
6	6	6	BGND	Battery ground.
7	7	7	TIP	Connects via protection resistor R <sub>P</sub> to tip wire of subscriber pair.

**Pin Descriptions** (Continued)

28 PIN PLCC	32 PIN PLCC	28 PIN SOIC	SYMBOL	DESCRIPTION
8	8	8	V <sub>BH</sub>	High Battery Supply (negative with respect to GND).
9	9	9	V <sub>BL</sub>	Low Battery Supply (negative with respect to GND, magnitude ≤ V <sub>BH</sub> ).
10	10	10	RDC_RAC	Resistive Feed/Anti Clipping - Performs anti clipping function on constant current application and sets the slope of the resistive feed curve for constant voltage applications.
11	11	14	CRT_REV_LVM	Ring Trip, Soft Polarity Reversal and Line Voltage Measurement - A capacitor when placed between the CRT_REV_LVM pin and +5V performs 3 mutually exclusive functions. When the SLIC is configured in the Ringing mode it provides filtering of the ringing signal to prevent false detect. When the SLIC is transitioning between the Forward Active State and Reverse Active State it provides Soft Polarity Reversal and performs charge storage in the Line Voltage Measurement State. Recommended value 0.47μF.
12	12	11	CDC	Filter Capacitor - The CDC Capacitor removes the VF signals from the battery feed control loop.
13	13	12	DT	Tip side of Ring Trip Detector - Ring trip detection is accomplished by connecting an external network to a detector in the SLIC with inputs DT and DR. Ring trip occurs when the voltage on DT is more negative than the voltage on DR.
14	14	13	DR	Ring Side of Ring Trip Detector - Ring trip detection is accomplished by connecting an external network to a detector in the SLIC with inputs DT and DR. Ring trip occurs when the voltage on DR is more positive than the voltage on DT.
-	15	-	C5	Activates Test Relay TRLY2. TTL Compatible Logic Input. C5 input high, test relay TRLT2 Low(ON). C5 input floating, test relay TRLY2 High(OFF). This is due to an internal 100kΩ pull down resistor.
-	16	-	C4	Activates Test Relay TRLY1. TTL Compatible Logic Input. C4 input high, test relay TRLT1 Low(ON). C4 input floating, test relay TRLY1 High(OFF). This is due to an internal 100kΩ pull down resistor.
15	17	16	C3	TTL Compatible Logic Input. The logic states of C1, C2 and C3 determine the operating states of the SLIC. Reference Table 1 for details.
16	18	17	C2	TTL Compatible Logic Input. The logic states of C1, C2 and C3 determine the operating states of the SLIC. Reference Table 1 for details.
17	19	18	C1	TTL Compatible Logic Input. The logic states of C1, C2 and C3 determine the operating states of the SLIC. Reference Table 1 for details.
18	20	19	SHD	Switch Hook Detect - Active during off hook, ground key and loopback. Reference Table 1 for details.
19	21	15	GKD_LVM	Ground Key Detector and Line Voltage Measurement - Reference Table 1 for details.
20	22	20	V <sub>CC</sub>	5V Supply.
21	23	21	RD	Loop Current Threshold Programming Pin - A resistor between this pin and ground will determine the trigger level for the loop current detect circuit. See Equation 7.
22	24	22	ROH	Off Hook Overload Setting Resistor - Used to set combined overhead for voice and pulse metering signals. See Equation 10.
23	25	23	ILIM	Current Limit Programming Pin - A resistor between this pin and ground will determine the constant current limit of the feed curve. See Equation 11.
24	26	24	RSYNC_REV	Ring Synchronization Input and Reversal Time Setting. A resistor between this pin and GND determines the polarity reversal time. Synchronization of the closing of the relay at zero voltage is achieved via a ring sync pulse (5V to 0V) synchronized to the ring signal zero voltage crossing (Reference Figure 18).
25	27	28	AGND	Analog ground
26	28	25	VRX	Receive Input - Ground referenced 4-wire side.
27	29	26	SPM	Pulse Metering Signal Input. If pulse metering is not used, then this pin should be grounded as close to the device pin as possible. Input impedance to ground = 125kΩ.
28	30	27	VTX	Transmit Output - Ground referenced 4-wire side.
-	31	-	TRLY2	Test Relay Driver 2. Open Collector Transistor. Internal Clamp between it's output and ground eliminates the need to place an external snubber diode across Test Relay Driver. TRLY2 may be connected to maximum of 14V.
-	32	-	TRLY1	Test Relay Driver 1. Open Collector Transistor. Internal Clamp between it's output and ground eliminates the need to place an external snubber diode across Test Relay Driver. TRLY1 may be connected to maximum of 14V.

Basic Application Circuit - Voice Only 28 Lead PLCC Package

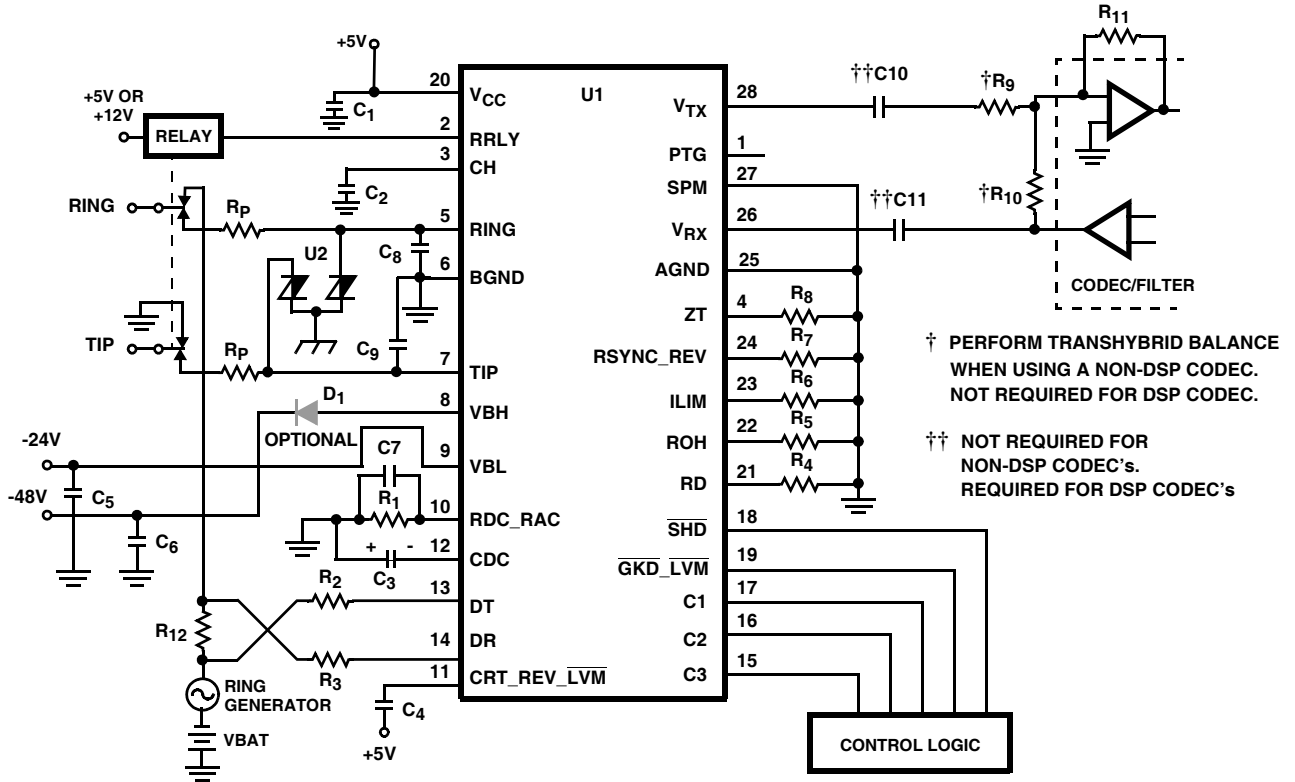

FIGURE 27. UniSLIC14 VOICE ONLY BASIC APPLICATION CIRCUIT

TABLE 2. BASIC APPLICATION CIRCUIT COMPONENT LIST

COMPONENT	VALUE	TOLERANCE	RATING
U1 - SLIC	UniSLIC14 Family	N/A	N/A
U2 - Dual Asymmetrical Transient Voltage Suppressor	TISP1072F3	N/A	N/A
RP (Line Feed Resistors)	30Ω	Matched 1%	2.0W
R1 (RDC_RAC Resistor)	21kΩ	1%	1/16W
R2, R3	2MΩ	1%	1/16W
R4 (RD Resistor)	41.2kΩ	1%	1/16W
R5 (ROH Resistor)	38.3kΩ	1%	1/16W
R6 (RILIM Resistor)	33.2kΩ	1%	1/16W
R7 (RSYNC_REV Resistor)	34.8kΩ	1%	1/16W
R8 (RZT Resistor)	107kΩ	1%	1/16W
R9, R10, R11	20kΩ	1%	1/16W
R12	400Ω	5%	2W
C1 (Supply Decoupling), C2	0.1μF	20%	10V
C5 (Supply Decoupling)	0.1μF	20%	50V
C6 (Supply Decoupling)	0.1μF	20%	100V
C4, C7, C10, C11	0.47μF	20%	10V
C3	4.7μF	20%	50V
C8, C9	2200pF	20%	100V
D1, Recommended if the VBL supply is not derived from the VBH Supply	1N4004	-	-

**Design Parameters:** Maximum on hook voltage =  $0.775V_{RMS}$ , Maximum Off hook Voice =  $3.2V_{PEAK}$ , Switch Hook Threshold = 12mA, Loop Current Limit = 31mA, Synthesize Device Impedance =  $540\Omega$  (600 - 60), with 30Ω protection resistors, impedance across Tip and Ring terminals =  $600\Omega$ . Where applicable, these component values apply to the Basic Application Circuits for the HC55120, HC55121, HC55130/1, HC55140/1, HC55142/3 and HC55150/1. Pins not shown in the Basic Application Circuit are no connect (NC) pins.

Basic Application Circuit - Pulse Metering 28 Lead PLCC Package

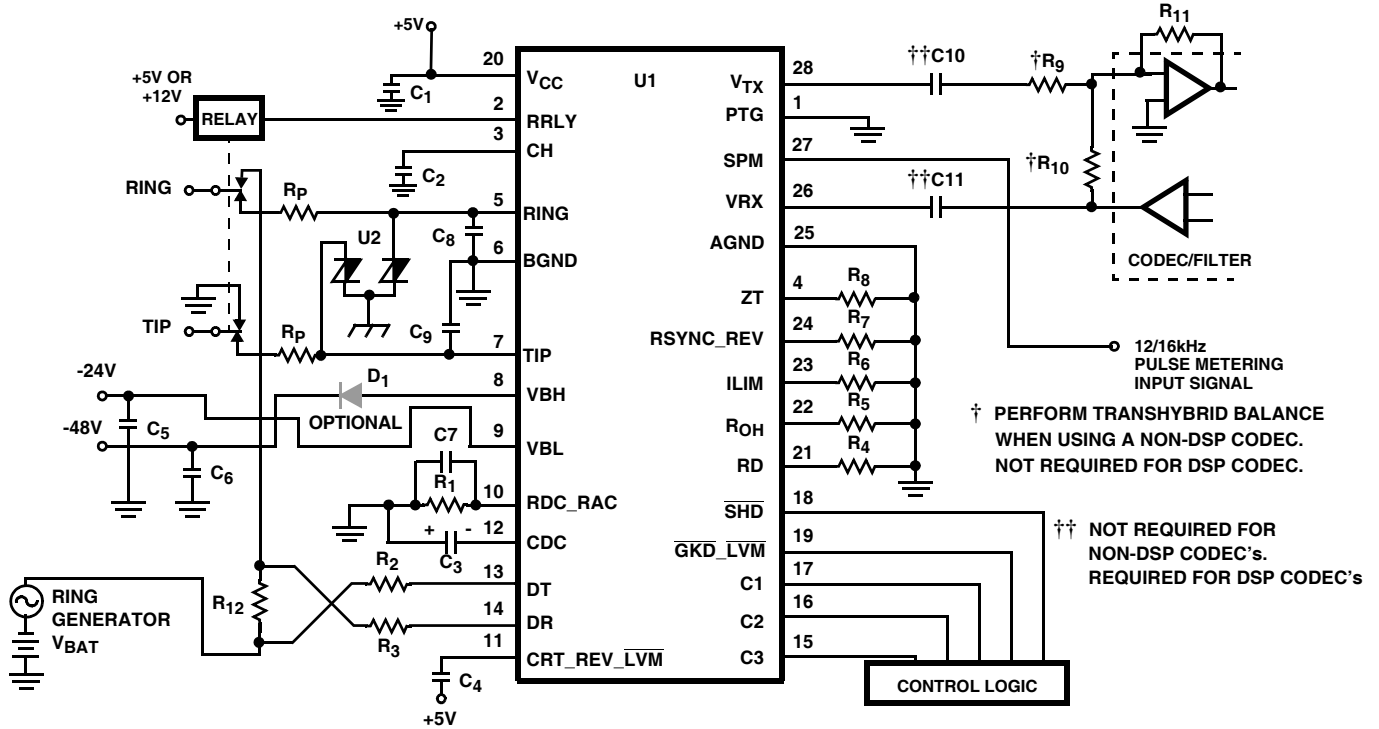

FIGURE 28. UniSLIC14 PULSE METERING BASIC APPLICATION CIRCUIT

TABLE 3. BASIC APPLICATION CIRCUIT COMPONENT LIST

COMPONENT	VALUE	TOLERANCE	RATING
U1 - SLIC	UniSLIC14 Family	N/A	N/A
U2 - Dual Asymmetrical Transient Voltage Suppressor	TISP1072F3	N/A	N/A
RP (Line Feed Resistors)	30Ω	Matched 1%	2.0W
R1 (RDC_RAC Resistor)	26.1kΩ	1%	1/16W
R2, R3	2MΩ	1%	1/16W
R4 (RD Resistor)	41.2kΩ	1%	1/16W
R5 (ROH Resistor)	38.3kΩ	1%	1/16W
R6 (RILIM Resistor)	33.2kΩ	1%	1/16W
R7 (RSYNC_REV Resistor)	34.8kΩ	1%	1/16W
R8 (RZT Resistor)	107kΩ	1%	1/16W
R9, R10, R11	20kΩ	1%	1/16W
R12	400Ω	5%	2W
C1 (Supply Decoupling), C2	0.1μF	20%	10V
C5 (Supply Decoupling)	0.1μF	20%	50V
C6 (Supply Decoupling)	0.1μF	20%	100V
C4, C7, C10, C11	0.47μF	20%	10V
C3	4.7μF	20%	50V
C8, C9	2200pF	20%	100V
D1, Recommended if the VBL supply is not derived from the VBH Supply	1N4004	-	-

**Design Parameters:** Maximum on hook voltage = 0.775V<sub>RMS</sub>, Maximum off hook voice = 1.1V<sub>PEAK</sub>, Maximum simultaneous pulse metering signal = 2.2V<sub>RMS</sub>, Switch Hook Threshold = 12mA, Loop Current Limit = 31mA, Synthesize Device Impedance = 540Ω (600 - 60), with 30Ω protection resistors, impedance across Tip and Ring terminals = 600Ω. Where applicable, these component values apply to the Basic Application Circuits for the HC55120, HC55121, HC55130/1, HC55140/1, HC55142/3 and HC55150/1. Pins not shown in the Basic Application Circuit are no connect (NC) pins.

Basic Application Circuit - Voice Only 28 Lead SOIC Package

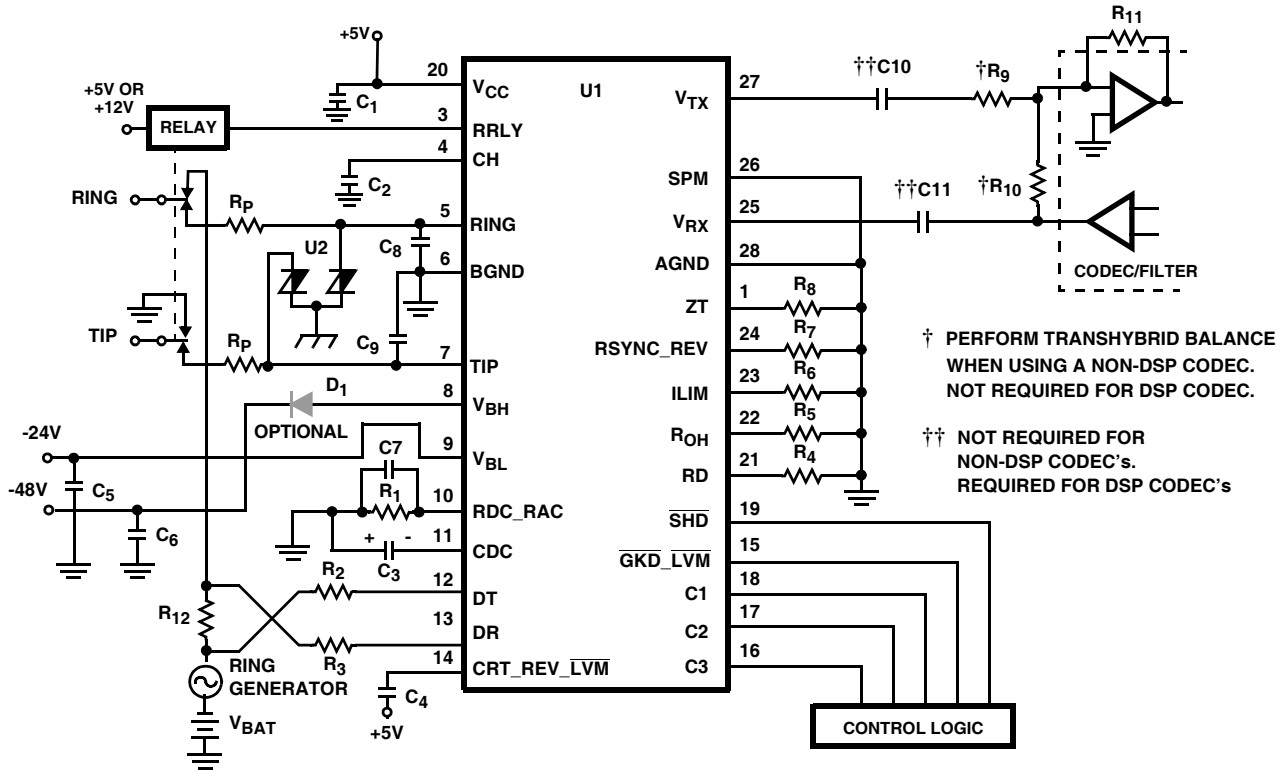

FIGURE 29. UniSLIC14 VOICE ONLY BASIC APPLICATION CIRCUIT

TABLE 4. BASIC APPLICATION CIRCUIT COMPONENT LIST

COMPONENT	VALUE	TOLERANCE	RATING
U1 - SLIC	UniSLIC14 Family	N/A	N/A
U2 - Dual Asymmetrical Transient Voltage Suppressor	TISP1072F3	N/A	N/A
RP (Line Feed Resistors)	30Ω	Matched 1%	2.0W
R1 (RDC_RAC Resistor)	21kΩ	1%	1/16W
R2, R3	2MΩ	1%	1/16W
R4 (RD Resistor)	41.2kΩ	1%	1/16W
R5 (ROH Resistor)	38.3kΩ	1%	1/16W
R6 (RILIM Resistor)	33.2kΩ	1%	1/16W
R7 (RSYNC_REV Resistor)	34.8kΩ	1%	1/16W
R8 (RZT Resistor)	107kΩ	1%	1/16W
R9, R10, R11	20kΩ	1%	1/16W
R12	400Ω	5%	2W
C1 (Supply Decoupling), C2	0.1μF	20%	10V
C5 (Supply Decoupling)	0.1μF	20%	50V
C6 (Supply Decoupling)	0.1μF	20%	100V
C4, C7, C10, C11	0.47μF	20%	10V
C3	4.7μF	20%	50V
C8, C9	2200pF	20%	100V
D1, Recommended if the VBL supply is not derived from the VBH Supply	1N4004	-	-

**Design Parameters:** Maximum on hook voltage = 0.775V<sub>RMS</sub>, Maximum Off hook Voice = 3.2V<sub>PEAK</sub>, Switch Hook Threshold = 12mA, Loop Current Limit = 31mA, Synthesize Device Impedance = 540Ω (600 - 60), with 30Ω protection resistors, impedance across Tip and Ring terminals = 600Ω. Where applicable, these component values apply to the Basic Application Circuits for the HC55120, HC55121, HC55130/1, HC55140/1, HC55142/3 and HC55150/1. Pins not shown in the Basic Application Circuit are no connect (NC) pins.

**Small Outline Plastic Packages (SOIC)**

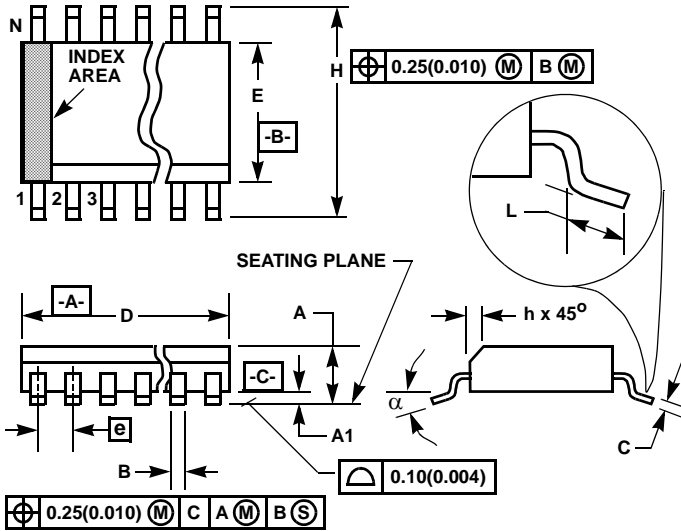

**M28.3 (JEDEC MS-013-AE ISSUE C)**  
**28 LEAD WIDE BODY SMALL OUTLINE PLASTIC PACKAGE**

SYMBOL	INCHES		MILLIMETERS		NOTES
	MIN	MAX	MIN	MAX	
A	0.0926	0.1043	2.35	2.65	-
A1	0.0040	0.0118	0.10	0.30	-
B	0.013	0.0200	0.33	0.51	9
C	0.0091	0.0125	0.23	0.32	-
D	0.6969	0.7125	17.70	18.10	3
E	0.2914	0.2992	7.40	7.60	4
e	0.05 BSC		1.27 BSC		-
H	0.394	0.419	10.00	10.65	-
h	0.01	0.029	0.25	0.75	5
L	0.016	0.050	0.40	1.27	6
N	28		28		7
$\alpha$	0°	8°	0°	8°	-

**NOTES:**

1. Symbols are defined in the "MO Series Symbol List" in Section 2.2 of Publication Number 95.
2. Dimensioning and tolerancing per ANSI Y14.5M-1982.
3. Dimension "D" does not include mold flash, protrusions or gate burrs. Mold flash, protrusion and gate burrs shall not exceed 0.15mm (0.006 inch) per side.
4. Dimension "E" does not include interlead flash or protrusions. Interlead flash and protrusions shall not exceed 0.25mm (0.010 inch) per side.
5. The chamfer on the body is optional. If it is not present, a visual index feature must be located within the crosshatched area.
6. "L" is the length of terminal for soldering to a substrate.
7. "N" is the number of terminal positions.
8. Terminal numbers are shown for reference only.
9. The lead width "B", as measured 0.36mm (0.014 inch) or greater above the seating plane, shall not exceed a maximum value of 0.61mm (0.024 inch)
10. Controlling dimension: MILLIMETER. Converted inch dimensions are not necessarily exact.

Rev. 0 12/93

**Plastic Leaded Chip Carrier Packages (PLCC)**

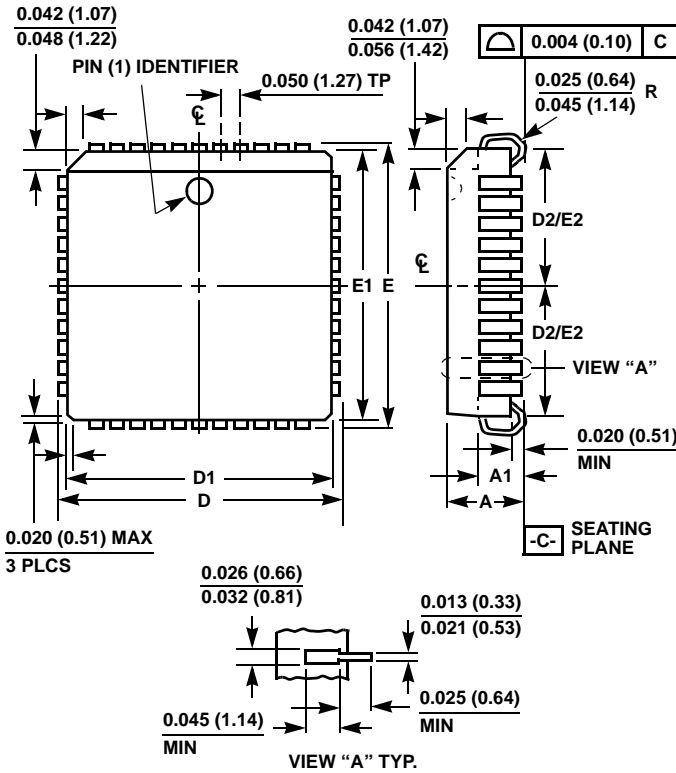

**N28.45 (JEDEC MS-018AB ISSUE A)  
28 LEAD PLASTIC LEADED CHIP CARRIER PACKAGE**

SYMBOL	INCHES		MILLIMETERS		NOTES
	MIN	MAX	MIN	MAX	
A	0.165	0.180	4.20	4.57	-
A1	0.090	0.120	2.29	3.04	-
D	0.485	0.495	12.32	12.57	-
D1	0.450	0.456	11.43	11.58	3
D2	0.191	0.219	4.86	5.56	4, 5
E	0.485	0.495	12.32	12.57	-
E1	0.450	0.456	11.43	11.58	3
E2	0.191	0.219	4.86	5.56	4, 5
N	28		28		6

Rev. 2 11/97

**NOTES:**

1. Controlling dimension: INCH. Converted millimeter dimensions are not necessarily exact.
2. Dimensions and tolerancing per ANSI Y14.5M-1982.
3. Dimensions D1 and E1 do not include mold protrusions. Allowable mold protrusion is 0.010 inch (0.25mm) per side. Dimensions D1 and E1 include mold mismatch and are measured at the extreme material condition at the body parting line.
4. To be measured at seating plane -C- contact point.
5. Centerline to be determined where center leads exit plastic body.
6. "N" is the number of terminal positions.

Plastic Leaded Chip Carrier Packages (PLCC)

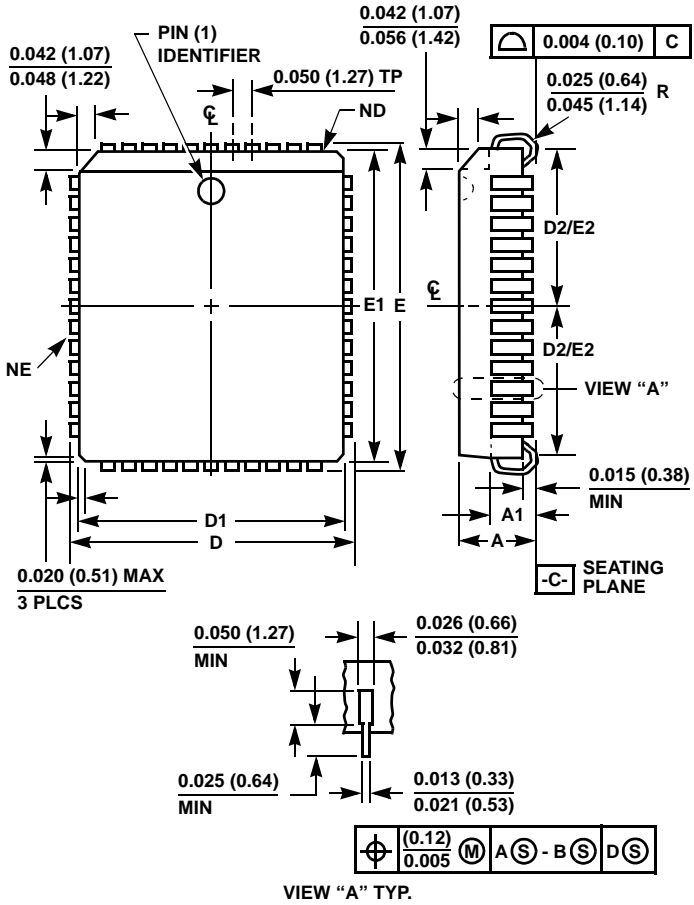

N32.45x55 (JEDEC MS-016AE ISSUE A)  
32 LEAD PLASTIC LEADED CHIP CARRIER PACKAGE

SYMBOL	INCHES		MILLIMETERS		NOTES
	MIN	MAX	MIN	MAX	
A	0.125	0.140	3.18	3.55	-
A1	0.060	0.095	1.53	2.41	-
D	0.485	0.495	12.32	12.57	-
D1	0.447	0.453	11.36	11.50	3
D2	0.188	0.223	4.78	5.66	4, 5
E	0.585	0.595	14.86	15.11	-
E1	0.547	0.553	13.90	14.04	3
E2	0.238	0.273	6.05	6.93	4, 5
N	28		28		6
ND	7		7		7
NE	9		9		7

Rev. 0 7/98

NOTES:

- Controlling dimension: INCH. Converted millimeter dimensions are not necessarily exact.
- Dimensions and tolerancing per ANSI Y14.5M-1982.
- Dimensions D1 and E1 do not include mold protrusions. Allowable mold protrusion is 0.010 inch (0.25mm) per side. Dimensions D1 and E1 include mold mismatch and are measured at the extreme material condition at the body parting line.
- To be measured at seating plane [-C-] contact point.
- Centerline to be determined where center leads exit plastic body.
- "N" is the number of terminal positions.
- ND denotes the number of leads on the two shorts sides of the package, one of which contains pin #1. NE denotes the number of leads on the two long sides of the package.

All Intersil U.S. products are manufactured, assembled and tested utilizing ISO9000 quality systems.  
Intersil Corporation's quality certifications can be viewed at [www.intersil.com/design/quality](http://www.intersil.com/design/quality)

*Intersil products are sold by description only. Intersil Corporation reserves the right to make changes in circuit design, software and/or specifications at any time without notice. Accordingly, the reader is cautioned to verify that data sheets are current before placing orders. Information furnished by Intersil is believed to be accurate and reliable. However, no responsibility is assumed by Intersil or its subsidiaries for its use; nor for any infringements of patents or other rights of third parties which may result from its use. No license is granted by implication or otherwise under any patent or patent rights of Intersil or its subsidiaries.*

For information regarding Intersil Corporation and its products, see [www.intersil.com](http://www.intersil.com)

## Looking for pricing, stock, or lifecycle information?

Click below to explore more details on WIN SOURCE:

 [View HC55142IMZ on WIN SOURCE](#)

 [Intersil Information](#)

## Optimize Your Supply Chain with WIN SOURCE Solutions

-  Global Sourcing Solution
-  Obsolete Management
-  Cost Control Management
-  Shortage Management
-  Alternative Solution
-  Excess Inventory Management