

# S1C17624/604/622/602/621

## 16-bit Single Chip Microcontroller

- Low Power MCU: Operating voltage 1.8V, 0.75uA/SLEEP, 2.3uA/HALT
- Built in Flash memory: 8.2MHz high-speed operation with 1.8V low voltage
- Built in LCD driver: 52SEG × 8COM(max.), power supply voltage booster circuit
- Analog I/F: 10-bit A/D converter, 24-bit R/F converter, Supply voltage detector
- Real time clock: calendar function(support leap year)

### ■ DESCRIPTIONS

The S1C17624/604/622/602/621 is a 16-bit MCU featuring high-speed low-power operations, compact dimensions, wide address space, and on-chip ICE. Based on an S1C17 CPU core, this product consists of a Flash memory, RAM, serial interface modules supporting sensors such as UART to support high-bit rate and IrDA1.0, SPI, and I2C, various timers, maximum 47 general input/output ports, maximum 52 segment × 8 common LCD driver and a power supply voltage booster circuit, A/D converter, R/F converter, supply voltage detector, and 32 kHz and maximum 8.2 MHz oscillator circuits.

It allows 8.2 MHz high-speed operation at a minimum of 1.8 V operating voltage, and executes a basic instruction in one clock cycle with 16-bit RISC processing. The S1C17624/604/622/602/621 also includes a coprocessor supporting multiplication, division, and MAC (multiply and accumulation) operations.

The on-chip ICE function allows onboard Flash programming/erasing, program debugging, and evaluations using the ICDmini (S5U1C17001H) that can be connected with three signal wires.

The S1C17624/604/622/602/621 is ideal for applications, such as health care products with sensors, sports watches, and meter modules that must be driven with battery power and require sensor interfaces and a high-definition LCD display.

### ■ FEATURES

The main features of the S1C17624/604/622/602/621 are listed below.

Model	S1C17624	S1C17604	S1C17622	S1C17602	S1C17621
CPU					
CPU core	Seiko Epson original 16-bit RISC CPU core S1C17				
Multiplier/Divider (COPRO)	<ul style="list-style-type: none"> <li>· 16-bit × 16-bit multiplier</li> <li>· 16-bit × 16-bit + 32-bit multiply and accumulation unit</li> <li>· 16-bit ÷ 16-bit divider</li> </ul>				
Embedded Flash memory					
Capacity	128K bytes		64K bytes		32K bytes
	(Can be used for both instructions and data.)				
Erase/program count	1,000 cycles (min.)				
Other	<ul style="list-style-type: none"> <li>· Read/program protection function</li> <li>· Allows on-board programming using a debugging tool such as ICDmini (S5U1C17001H) and self-programming by software control.</li> </ul>				
Embedded RAM					
Capacity	8K bytes		4K bytes		2K bytes
Embedded Display RAM					
Capacity	56 bytes	40 bytes	56 bytes	40 bytes	
Clock generator					
System clock source	3 sources (IOSC/OSC3/OSC1)				
IOSC oscillator circuit	2.7 MHz(typ.) internal oscillator circuit (oscillation start time 5 μs min.)				
OSC3 oscillator circuit	8.2 MHz (max.) crystal or ceramic oscillator circuit Supports an external clock input.				
OSC1 oscillator circuit	32.768 kHz (typ.) crystal oscillator circuit Supports an external clock input.				
Other	<ul style="list-style-type: none"> <li>· Core clock frequency control</li> <li>· Peripheral module clock supply control</li> <li>· IOSC control for quick-restart processing from SLEEP mode</li> </ul>				
Real-time clock					
RTC module	Included (Contains second, minute, hour, day, days of week, month, and year counters.)				

# S1C17624/604/622/602/621

Model	S1C17624	S1C17604	S1C17622	S1C17602	S1C17621
I/O ports					
Number of general-purpose I/O ports	Max. 47 bits	Max. 36 bits	Max. 47 bits	Max. 36 bits	
	(Pins are shared with the peripheral I/O.)				
Serial interfaces					
SPI	1 channel				
I <sup>2</sup> C master (I2CM)	1 channel				
I <sup>2</sup> C slave (I2CS)	1 channel				
UART	2 channels (IrDA1.0 supported)				
IR remote controller (REMC)	1 channel				
LCD driver					
LCD outputs	· 56SEG × 4COM · 52SEG × 8COM	· 40SEG × 4COM · 36SEG × 8COM	· 56SEG × 4COM · 52SEG × 8COM	· 40SEG × 4COM · 36SEG × 8COM	
Other	1/3 bias (built-in power supply voltage booster circuit)				
Timers					
8-bit timer (T8F)	2 channels (with fine mode)				
16-bit timer (T16)	3 channels				
16-bit PWM timer (T16E)	1 channel				
16-bit PWM timer (T16A2)	2 channels				
8-bit OSC1 timer (T8OSC1)	1 channel				
Clock timer (CT)	1 channel				
Stopwatch timer (SWT)	1 channel				
Watchdog timer (WDT)	1 channel				
A/D converter					
Conversion method	Successive approximation type				
Number of analog input channels	8 channels (max.)				
Resolution	10 bits				
R/F converter					
Conversion method	CR oscillation type with 24-bit counter				
Number of conversion channels	2 channels (2 sensors can be connected to each channel.)				
Sensor supported	DC-bias resistive/capacitive sensors and AC-bias resistive sensors				
Other	Supports external input for counting pulses				
Supply voltage detector (SVD)					
Detection levels	15 programmable detection levels (1.8 V to 3.2 V)				
Interrupts					
Reset interrupt	#RESET pin				
NMI	Watchdog timer				
Programmable interrupts	20 systems (8 levels)		19 systems (8 levels)		
Power supply voltage					
Operating voltage (VDD)	<ul style="list-style-type: none"> <li>· 1.8 V to 3.6 V (for normal operation)</li> <li>· 2.7 V to 3.6 V (for Flash erasing/programming)</li> <li>· Built-in voltage regulator (two operating voltages switchable)</li> </ul>				
Analog voltage (AVDD)	AVDD = VDD				
Operating temperature					
Operating temperature range	-25°C to 70°C				
Current consumption (Typ. value)					
SLEEP state (ISLP)	0.75μA				
	OSC1 = OFF, IOSC = OFF, OSC3 = OFF				
HALT state (IHALT1)	2.3μA		2.5μA		
	OSC1 = 32kHz, IOSC = OFF, OSC3 = OFF, PCKEN[1:0] = 0x0, LCD OFF				
HALT state (IHALT1 + ILCD2)	4.0μA		3.5μA		
	OSC1 = 32kHz, IOSC = OFF, OSC3 = OFF, PCKEN[1:0] = 0x0, LCD ON (checker pattern displayed, highest contrast, VC2 reference voltage)				
Run state (IEXE1)	14μA		15μA		
	CPU = OSC1, OSC1 = 32kHz, IOSC = OFF, OSC3 = OFF, LCD OFF				
Run state (IEXE2)	400μA		410μA		
	CPU = OSC3, OSC1 = 32kHz, IOSC = OFF, OSC3 = 1MHz ceramic oscillation				

# S1C17624/604/622/602/621

Model	S1C17624	S1C17604	S1C17622	S1C17602	S1C17621
Shipping form					
1	TQFP15-128pin	TQFP14-100pin	TQFP15-128pin	TQFP14-100pin	
2	Die form				
3					VFBGA7H-144
Size/pitch	TQFP15-128pin (body size: 14 mm × 14 mm, lead pitch: 0.4 mm) TQFP14-100pin (body size: 12 mm × 12 mm, lead pitch: 0.4 mm) VFBGA7H-144 (body size: 7 mm × 7 mm, ball pitch: 0.5 mm) Die form (pad pitch: 100 μm)				

## ■ BLOCK DIAGRAM

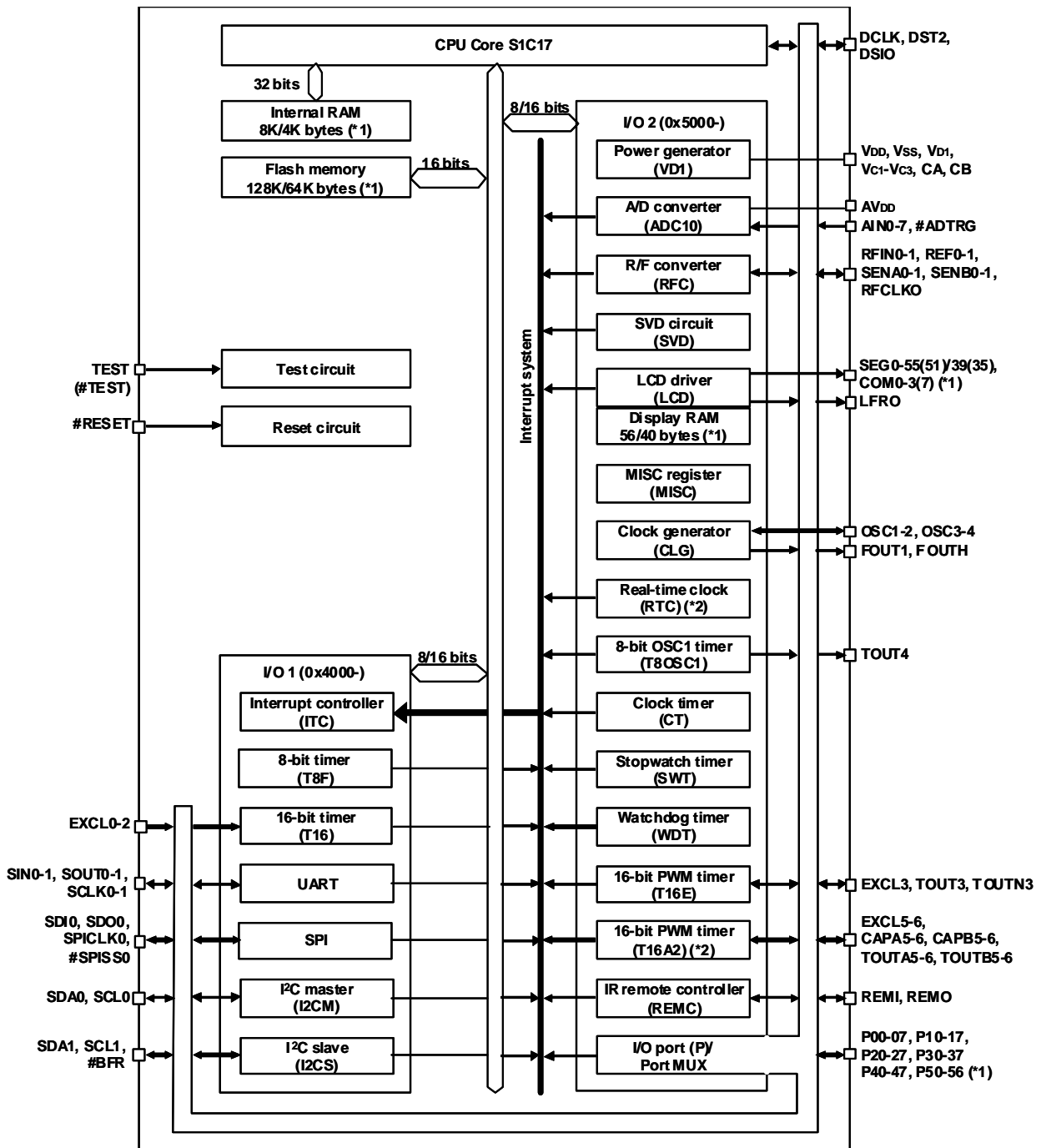

# S1C17624/604/622/602/621

- \*1: The models have a different memory size, LCD outputs and I/O port configurations.  
\*2: The real-time clock (RTC) and 16-bit PWM timer (T16A2) are available only in the S1C17624 and S1C17604.

## NOTICE:

No part of this material may be reproduced or duplicated in any form or by any means without the written permission of Seiko Epson. Seiko Epson reserves the right to make changes to this material without notice. Seiko Epson does not assume any liability of any kind arising out of any inaccuracies contained in this material or due to its application or use in any product or circuit and, further, there is no representation that this material is applicable to products requiring high level reliability, such as, medical products. Moreover, no license to any intellectual property rights is granted by implication or otherwise, and there is no representation or warranty that anything made in accordance with this material will be free from any patent or copyright infringement of a third party. This material or portions thereof may contain technology or the subject relating to strategic products under the control of the Foreign Exchange and Foreign Trade Law of Japan and may require an export license from the Ministry of Economy, Trade and Industry or other approval from another government agency. All brands or product names mentioned herein are trademarks and/or registered trademarks of their respective companies.

©Seiko Epson Corporation 2010, All rights reserved.

■ EPSON Electronic devices Website

[http://www.epson.jp/device/semicon\\_e/](http://www.epson.jp/device/semicon_e/)

## SEIKO EPSON CORPORATION

SEMICONDUCTOR OPERATIONS DIVISION

### IC Sales Department

### IC International Sales Group

421-8 Hino, Hino-shi, Tokyo 191-8501, JAPAN  
Phone: 042-587-5814 FAX: 042-587-5117

Document code: 411828100

First issue April, 2010

## Looking for pricing, stock, or lifecycle information?

Click below to explore more details on WIN SOURCE:

- [View S1C17602F101100 on WIN SOURCE](#)
- [Epson Electronics America Inc-Semiconductor Div Information](#)

## Optimize Your Supply Chain with WIN SOURCE Solutions

- ✓ Global Sourcing Solution
- ✓ Obsolete Management
- ✓ Cost Control Management
- ✓ Shortage Management
- ✓ Alternative Solution
- ✓ Excess Inventory Management