



## Metallurgically Bonded Glass Surface Mount 1.5 Watt Zener Diodes

Screening in  
reference to  
MIL-PRF-19500  
available

### DESCRIPTION

This surface mountable 1.5 W Zener diode series in the JEDEC DO-213AB package is similar in electrical features to the JEDEC registered 1N5913B through 1N5956B axial-leaded package for 3.3 to 200 V. It is an ideal selection for applications of high density and low parasitic requirements. Due to its glass hermetic qualities and metallurgically enhanced internal contacts, it may also be used for high reliability applications when required by a source control drawing (SCD) or screening in accordance with MIL-PRF-19500 as described in Features below.

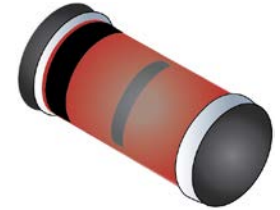

**DO-213AB MELF  
Package**

**Important:** For the latest information, visit our website <http://www.microsemi.com>.

### FEATURES

- Surface mount equivalent of JEDEC registered 1N5913B TO 1N5956B number series.
- Zener voltage available 3.3 V to 200 V.
- Voltage tolerances of 10%, 5%, 2% and 1% are available.
- Screening in reference to MIL-PRF-19500 is available.  
(See [part nomenclature](#) for all available options.)
- RoHS compliant versions are available.

Also available in:

#### DO-41 package

(glass axial-leaded)

 [1N5913BG – 1N5956BG](#)

#### SMB package

(tabbed surface mount)

 [SMBG\(J\)5913B –  
SMBG\(J\)5956E](#)

#### SMAJ package

(tabbed surface mount)

 [SMAJ5913B –  
SMAJ5956E](#)

#### Powermite package

(tabbed surface mount)

 [1PMT5913B –  
1PMT5956E](#)

### APPLICATIONS / BENEFITS

- Regulates voltage over a broad ranges of operation current and temperature.
- Leadless package ideal for high-density surface mounting.
- Metallurgically enhanced internal contact design for greater reliability and lower thermal resistance.
- Hermetically sealed glass package.
- Non-sensitive to ESD per MIL-STD-750 method 1020.
- Specified capacitance (see [figure 2](#)).
- Inherently radiation hard as described in Microsemi [MicroNote 050](#).

### MAXIMUM RATINGS @ $T_A = 25^\circ\text{C}$ unless otherwise specified

Parameters/Test Conditions	Symbol	Value	Unit
Junction and Storage Temperature	$T_J$ & $T_{STG}$	-65 to +175	$^\circ\text{C}$
Thermal Resistance Junction-to-End Cap	$R_{\theta JEC}$	40	$^\circ\text{C/W}$
Thermal Resistance Junction-to-Ambient <sup>(1)</sup>	$R_{\theta JA}$	120	$^\circ\text{C/W}$
Steady State Power Dissipation @ $T_{EC} \leq 115^\circ\text{C}$ @ $T_A = 25^\circ\text{C}$ <sup>(1)</sup>	$P_D$	1.5 1.25	W
Rated Average Power Dissipation (also see <a href="#">figure 1</a> )	$P_{M(AV)}$	1.5	W
Forward Voltage @ 200 mA	$V_F$	1.2	V
Solder Temperature @ 10 s	$T_{SP}$	260	$^\circ\text{C}$

**Notes:** 1. When mounted on FR4 PC board (1 oz Cu) with recommended footprint (see last page).

#### MSC – Lawrence

6 Lake Street,  
Lawrence, MA 01841  
Tel: 1-800-446-1158 or  
(978) 620-2600  
Fax: (978) 689-0803

#### MSC – Ireland

Gort Road Business Park,  
Ennis, Co. Clare, Ireland  
Tel: +353 (0) 65 6840044  
Fax: +353 (0) 65 6822298

Website:

[www.microsemi.com](http://www.microsemi.com)

**MECHANICAL and PACKAGING**

- CASE: Hermetically sealed voidless hard glass with tungsten slugs.
- TERMINALS: Tin/lead or RoHS compliant matte/tin plating over copper. Solderable per MIL-STD-750, method 2026.
- MARKING: Cathode band only.
- POLARITY: Cathode indicated by band. Diode to be operated with the banded end positive with respect to the opposite end for Zener regulation.
- TAPE & REEL option: Standard per EIA-481-B with 12mm tape (add TR suffix to part number). Consult factory for quantities.
- WEIGHT: Approximately 0.05 grams.
- See [package dimensions](#) on last page.

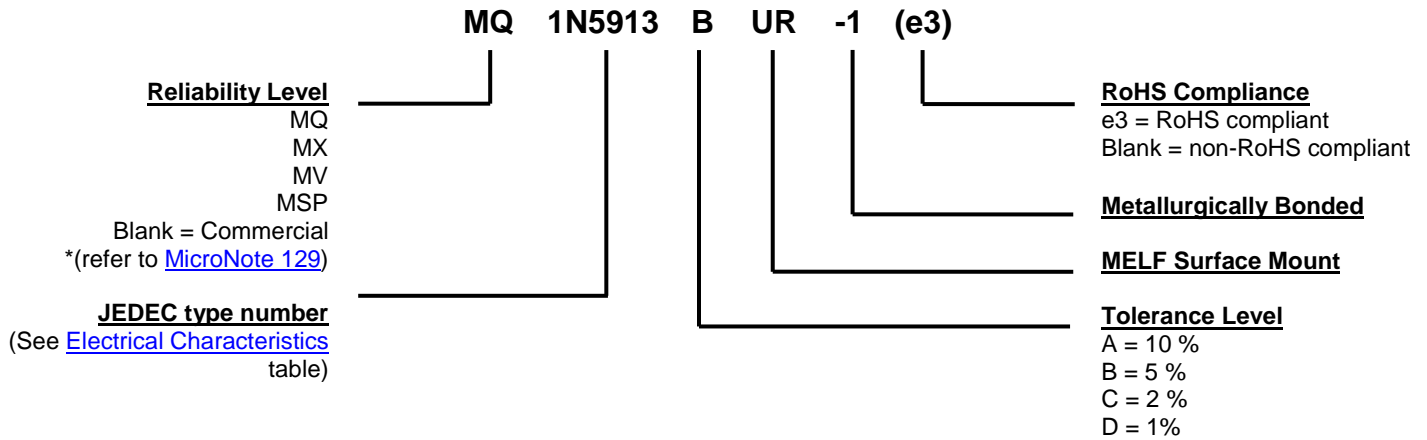
**PART NOMENCLATURE**

**SYMBOLS & DEFINITIONS**

Symbol	Definition
$V_Z$	Zener Voltage: The Zener voltage the device will exhibit at a specified current ( $I_Z$ ) in its breakdown region.
$I_Z, I_{ZT}, I_{ZK}$	Regulator Current: The dc regulator current ( $I_Z$ ), at a specified test point ( $I_{ZT}$ ), near breakdown knee ( $I_{ZK}$ ).
$Z_{ZT}$ or $Z_{ZK}$	Regulator Impedance: The small signal impedance of the diode when biased to operate in its breakdown region with $I_{ZT}$ applied at $I_Z$ or $I_{ZK}$ respectively. This has also been known as Zener or dynamic impedance ( $Z_{ZT}$ or $Z_{ZK}$ ).
$V_F$	Forward Voltage: The positive dc anode-cathode voltage the device will exhibit at a specified forward current.
$I_R$	Reverse Current: The dc current flowing from the external circuit into the cathode terminal at the specified voltage $V_R$ .
$I_{ZM}$	Maximum Regulator (Zener) Current: The maximum rated dc current for the specified power rating.

**ELECTRICAL CHARACTERISTICS @  $T_{EC} = 25\text{ }^{\circ}\text{C}$  unless otherwise noted**

PART NUMBER (Note 3)	ZENER VOLTAGE $V_Z$ (Note 1)	TEST CURRENT $I_{ZT}$	DYNAMIC IMPEDANCE $Z_{ZT}$ (Note 2)	KNEE CURRENT $I_{ZK}$	KNEE IMPEDANCE $Z_{ZK}$ (Note 2)	REVERSE CURRENT $I_R$	REVERSE VOLTAGE $V_R$	MAX. DC CURRENT $I_{ZM}$
	Volts	mA	Ohms	mA	Ohms	$\mu\text{A}$	Volts	mA
1N5913BUR-1	3.3	113.6	10	1.0	500	100	1.0	454
1N5914BUR-1	3.6	104.2	9.0	1.0	500	75	1.0	416
1N5915BUR-1	3.9	96.1	7.5	1.0	500	25	1.0	384
1N5916BUR-1	4.3	87.2	6.0	1.0	500	5.0	1.0	348
1N5917BUR-1	4.7	79.8	5.0	1.0	500	5.0	1.5	319
1N5918BUR-1	5.1	73.5	4.0	1.0	350	5.0	2.0	294
1N5919BUR-1	5.6	66.9	2.0	1.0	250	5.0	3.0	267
1N5920BUR-1	6.2	60.5	2.0	1.0	200	5.0	4.0	241
1N5921BUR-1	6.8	55.1	2.5	1.0	200	5.0	5.2	220
1N5922BUR-1	7.5	50.0	3.0	0.5	400	5.0	6.0	200
1N5923BUR-1	8.2	45.7	3.5	0.5	400	5.0	6.5	182
1N5924BUR-1	9.1	41.2	4.0	0.5	500	5.0	7.0	164
1N5925BUR-1	10	37.5	4.5	0.25	500	5.0	8.0	150
1N5926BUR-1	11	34.1	5.5	0.25	550	1.0	8.4	136
1N5927BUR-1	12	31.2	6.5	0.25	550	1.0	9.1	125
1N5928BUR-1	13	28.8	7.0	0.25	550	1.0	9.9	115
1N5929BUR-1	15	25.0	9.0	0.25	600	1.0	11.4	100
1N5930BUR-1	16	23.4	10	0.25	600	1.0	12.2	93
1N5931BUR-1	18	20.8	12	0.25	650	1.0	13.7	83
1N5932BUR-1	20	18.7	14	0.25	650	1.0	15.2	75
1N5933BUR-1	22	17.0	17.5	0.25	650	1.0	16.7	68
1N5934BUR-1	24	15.6	19	0.25	700	1.0	18.2	62
1N5935BUR-1	27	13.9	23	0.25	700	1.0	20.6	55
1N5936BUR-1	30	12.5	28	0.25	750	1.0	22.8	50
1N5937BUR-1	33	11.4	33	0.25	800	1.0	25.1	45
1N5938BUR-1	36	10.4	38	0.25	850	1.0	27.4	41
1N5939BUR-1	39	9.6	45	0.25	900	1.0	29.7	38
1N5940BUR-1	43	8.7	53	0.25	950	1.0	32.7	34
1N5941BUR-1	47	8.0	67	0.25	1000	1.0	35.8	31
1N5942BUR-1	51	7.3	70	0.25	1100	1.0	38.8	29
1N5943BUR-1	56	6.7	86	0.25	1300	1.0	42.6	26
1N5944BUR-1	62	6.0	100	0.25	1500	1.0	47.1	24
1N5945BUR-1	68	5.5	120	0.25	1700	1.0	51.2	22
1N5946BUR-1	75	5.0	140	0.25	2000	1.0	56.0	20
1N5947BUR-1	82	4.6	160	0.25	2500	1.0	62.2	18
1N5948BUR-1	91	4.1	200	0.25	3000	1.0	69.2	16
1N5949BUR-1	100	3.7	250	0.25	3100	1.0	76.0	15
1N5950BUR-1	110	3.4	300	0.25	4000	1.0	83.6	13
1N5951BUR-1	120	3.1	380	0.25	4500	1.0	91.2	12
1N5952BUR-1	130	2.9	450	0.25	5000	1.0	98.9	11
1N5953BUR-1	150	2.5	600	0.25	6000	1.0	114.0	10
1N5954BUR-1	160	2.3	700	0.25	6500	1.0	121.6	9
1N5955BUR-1	180	2.1	900	0.25	7000	1.0	136.8	8
1N5956BUR-1	200	1.9	1200	0.25	8000	1.0	152.0	7

\*  $T_{EC}$  Maintained at  $30\text{ }^{\circ}\text{C}$ ,  $V_F = 1.2\text{ V}$  max @  $I_F = 200\text{ mA}$  (all types).

**NOTES:**

- Zener voltage ( $V_Z$ ) is measured at end cap temperatures  $T_{EC} = 30\text{ }^{\circ}\text{C}$ . Voltage measurement to be performed 90 seconds after application of dc current.
- The Zener impedance is derived from the 60 Hz ac voltage, which results when an ac current having an rms value equal to 10% of the dc Zener current ( $I_{ZT}$  or  $I_{ZK}$ ) is superimposed on  $I_{ZT}$  or  $I_{ZK}$ .
- This product series has also been previously identified as the CDLL5913B through CDLL5956B series that included the enhanced metallurgical bond. This alternate name may still be used.

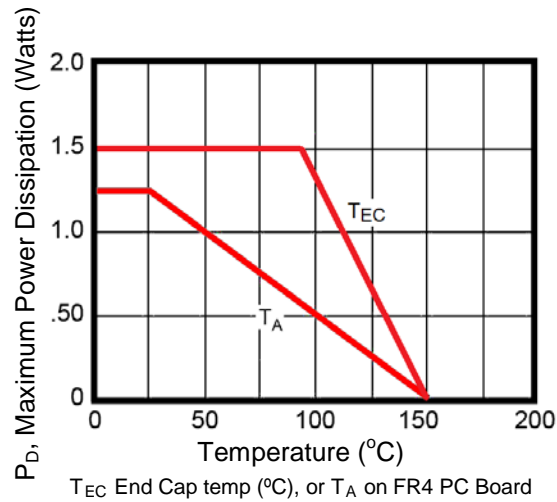
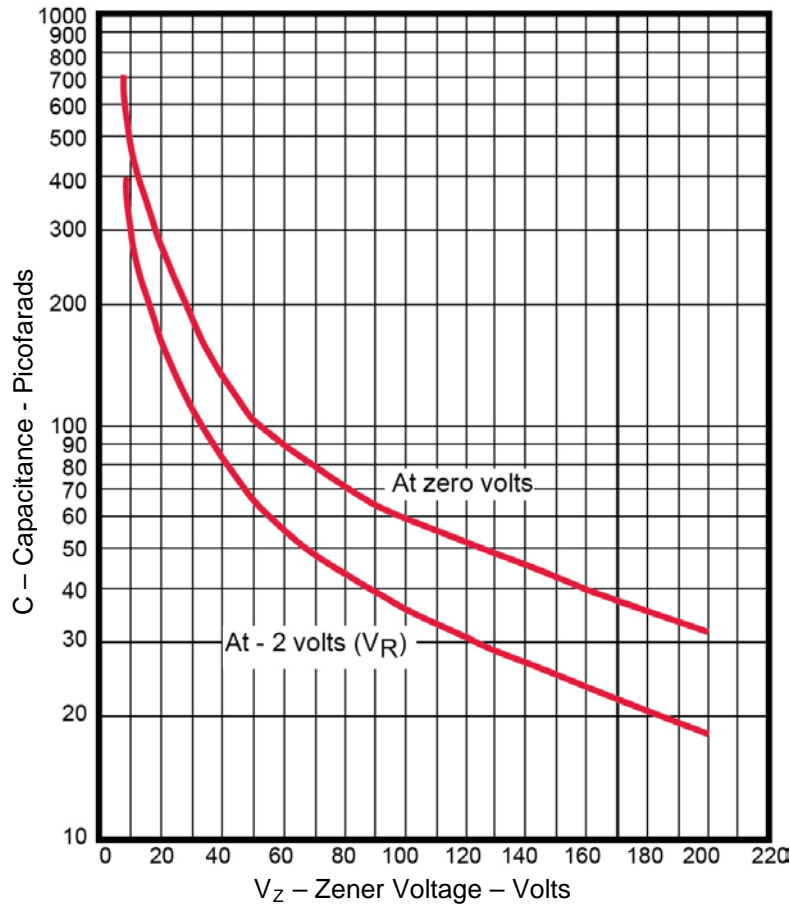
**GRAPHS**

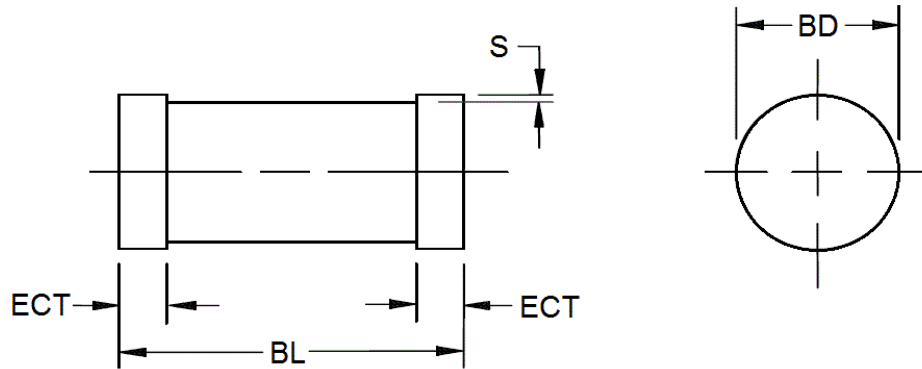
**FIGURE 1 – Power Derating Curve**

**FIGURE 2 – Capacitance vs Zener Voltage**

**PACKAGE DIMENSIONS**

Symbol	Dimensions			
	Inch		Millimeters	
	Min	Max	Min	Max
<b>BD</b>	0.094	0.105	2.39	2.67
<b>BL</b>	0.189	0.205	4.80	5.21
<b>ECT</b>	0.014	0.022	0.360	0.560
<b>S</b>	0.001 min		0.03 min	

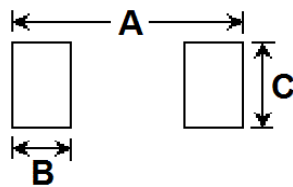
**NOTES:**



1. Dimensions are in inches. Millimeters are given for general information only.
2. Gap not controlled, shape of body and gap not controlled.
3. In accordance with ASME Y14.5M, diameters are equivalent to  $\Phi$ x symbology.

**PAD LAYOUT**

Ltr	Inch	mm
<b>A</b>	0.276	7.00
<b>B</b>	0.070	1.8
<b>C</b>	0.110	2.8

## Looking for pricing, stock, or lifecycle information?

Click below to explore more details on WIN SOURCE:

-  [View CDLL5952B on WIN SOURCE](#)
-  [Microsemi Corporation](#) Information

## Optimize Your Supply Chain with WIN SOURCE Solutions

-  Global Sourcing Solution
-  Obsolete Management
-  Cost Control Management
-  Shortage Management
-  Alternative Solution
-  Excess Inventory Management