



**THE DATASHEET OF
LM98725CCMTX/NOPB**



LM98725 3 Channel, 16-Bit, 81 MSPS Analog Front End with LVDS/CMOS Output, Integrated CCD/CIS Sensor Timing Generator and Spread Spectrum Clock Generation

1 Features

- LVDS/CMOS Outputs
- LVDS/CMOS/Crystal Clock Source with PLL Multiplication
- Integrated Flexible Spread Spectrum Clock Generation
- CDS or S/H Processing for CCD or CIS Sensors
- Independent Gain/Offset Correction for Each Channel
- Automatic per-Channel Gain and Offset Calibration
- Programmable Input Clamp Voltage
- Flexible CCD/CIS Sensor Timing Generator

2 Applications

- Multi-Function Peripherals
- High-speed Currency/Check Scanners
- Flatbed or Handheld Color Scanners
- High-speed Document Scanners
- **Key Specifications:**
 - Maximum Input Level
 - 1.2 or 2.4 Volt Modes
 - (Both with + or - Polarity Option)
 - ADC Resolution: 16-Bit
 - ADC Sampling Rate: 81 MSPS
 - INL: +17/- 28 LSB (typ)
 - Channel Sampling Rate: 30/30/27 MSPS
 - PGA Gain Steps: 256 Steps
 - PGA Gain Range: 0.62 to 8.3x
 - Analog DAC Resolution: ± 9 Bits
 - Analog DAC Range: ± 307 mV or ± 614 mV
 - Digital DAC Resolution: ± 6 Bits
 - Digital DAC Range: -2048 LSB to + 2016 LSB
 - SNR: -74dB (@0 dB PGA Gain)
 - Power Dissipation: 755 mW (LVDS)
 - Operating Temp: 0 to 70°C
 - Supply Voltage: 3.3 V Nominal (3.0-V to 3.6-V Range)

3 Description

The LM98725 is a fully integrated, high performance 16-Bit, 81 MSPS signal processing solution for digital color copiers, scanners, and other image processing applications. The LM98725 achieves high-speed signal throughput with an innovative architecture utilizing Correlated Double Sampling (CDS), typically employed with CCD arrays, or Sample and Hold (S/H) inputs (for higher speed CCD or CMOS image sensors). The signal paths utilize 8 bit Programmable Gain Amplifiers (PGA), a ± 9 -Bit offset correction DAC, and independently controlled Digital Black Level correction loops for each input. The independently programmed PGA and offset DAC allow unique values of gain and offset for each of the three analog inputs. The signals are then routed to a 81 MHz high performance analog-to-digital converter (ADC). The fully differential processing channel shows exceptional noise immunity with a very low noise floor of -74 dB. The 16-bit ADC has excellent dynamic performance making the LM98725 transparent in the image reproduction chain.

A very flexible integrated Spread Spectrum Clock Generation (SSCG) modulator is included to assist with EM compliance and reduce system costs.

Device Information⁽¹⁾

PART NUMBER	PACKAGE	BODY SIZE (NOM)
LM98725	TSSOP (56)	14.0 mm x 6.10 mm

(1) For all available packages, see the orderable addendum at the end of the datasheet.

System Block Diagram

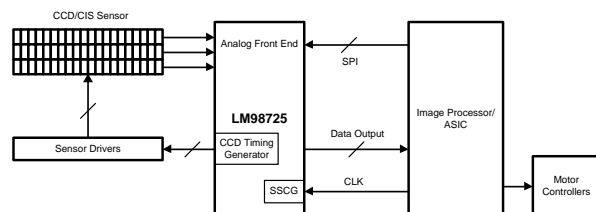

Table of Contents

1 Features	1	7.1 Overview	14
2 Applications	1	7.2 Functional Block Diagrams	15
3 Description	1	7.3 Feature Description	16
4 Revision History	2	7.4 Device Functional Modes	24
5 Pin Configuration and Functions	3	7.5 Register Maps	88
6 Specifications	6	8 Layout	136
6.1 Absolute Maximum Ratings	6	8.1 Layout Example	136
6.2 Handling Ratings	6	9 Device and Documentation Support	137
6.3 Recommended Operating Conditions	6	9.1 Trademarks	137
6.4 Electrical Characteristics	7	9.2 Device Support	137
6.5 AC Timing Specifications	11	9.3 Electrostatic Discharge Caution	137
6.6 Serial Interface Timing Details	13	9.4 Glossary	137
7 Detailed Description	14	10 Mechanical, Packaging, and Orderable Information	137

4 Revision History

NOTE: Page numbers for previous revisions may differ from page numbers in the current version.

Changes from Revision G (October 2014) to Revision H	Page
• Changed "29" to "33" for Pin number 32 in Pin Functions	4
• Deleted "Boldface limits apply..." statement in <i>Electrical Characteristics</i> and <i>AC Timing Specifications</i>	7
• Changed "internal" to "external" and "external" to "internal" for "SH_R Capture Clock Select (Page 0, Register 0x00, Bit 5)" heading in <i>Clock Sources - Additional Settings and Flexibility</i>	18
• Changed 25 MHz to 27 MHz and 75 MHz to 81 MHz for <i>Table 3</i>	24
• Changed "Page 2" to "Page 0" in <i>CCD Timing Generator Master/Slave Modes</i>	63
• Changed "Page 2" to "Page 0" in <i>Master Timing Generator Mode</i>	63
• Changed "1100 0000" to " 1100 0010" in <i>Table 18</i>	101

Changes from Revision F (January 2014) to Revision G	Page
• Added, updated, or renamed the following sections: Device Information Table, <i>Pin Configuration and Functions</i> ; <i>Layout</i> ; <i>Device and Documentation Support</i> ; <i>Mechanical, Packaging, and Ordering Information</i>	1
• Added "Note" in <i>Serial Interface</i>	84

Changes from Revision E (April 2013) to Revision F	Page
• Added content from System Overview section to end of document.	16

Changes from Revision D (April 2009) to Revision E	Page
• Changed layout of National Data Sheet to TI format	13

5 Pin Configuration and Functions

**56-Pin TSSOP
Package DGG
Top View**

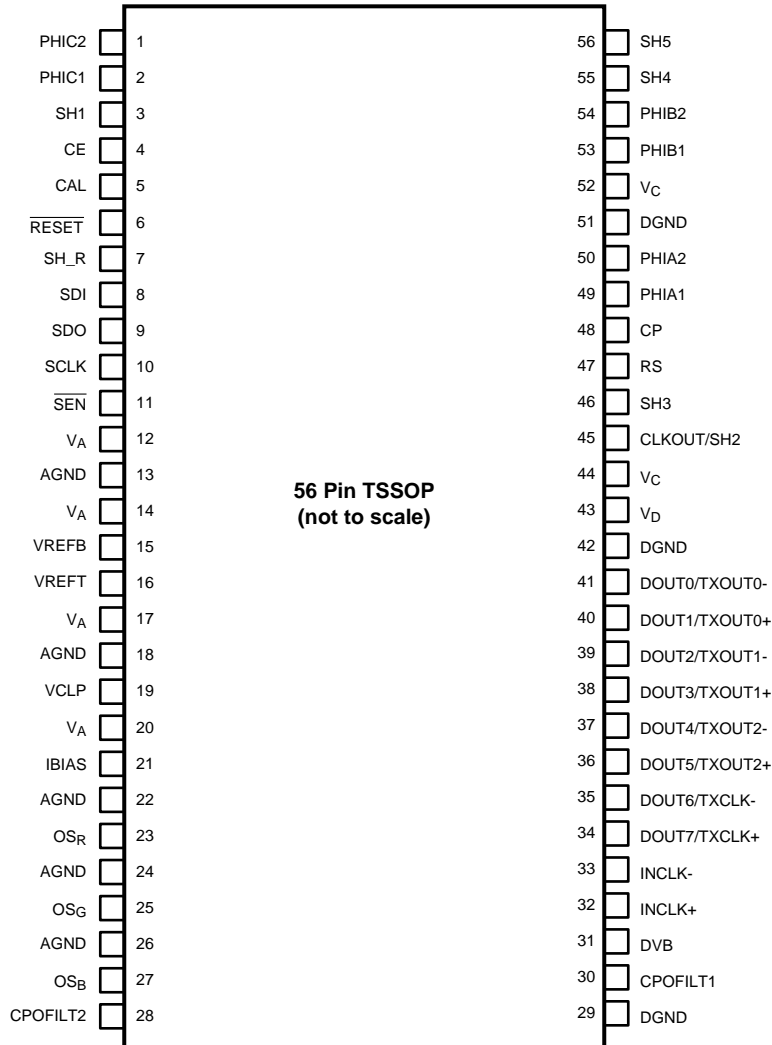

Pin Functions

PIN		I/O	TYP	RES	DESCRIPTION
NO.	NAME				
1	PHIC2	O	D		Configurable high speed sensor timing output.
2	PHIC1	O	D		Configurable high speed sensor timing output.
3	SH1	O	D		Configurable low speed sensor timing output.
4	CE	I	D		Chip Serial Interface Address Setting Input CE Level Address VD 01 Float 10 DGND 00
5	CAL	I	D	PD	Initiate calibration sequence. Leave unconnected or tie to DGND if unused.
6	$\overline{\text{RESET}}$	I	D	PU	Active-low master reset. NC when function not being used.
7	SH_R	I	D	PD	External request for an SH pulse.
8	SDI	I	D	PD	Serial Interface Data Input. Can be tied to SDO for compatibility with LM98714 designs.
9	SDO	O	D		Serial Interface Data Output. Can be tied to SDI for compatibility with LM98714 designs.
10	SCLK	I	D	PD	Serial Interface shift register clock.
11	$\overline{\text{SEN}}$	I	D	PU	Active-low chip enable for the Serial Interface.
12	V _A		P		Analog power supply. Bypass voltage source with 4.7μF and pin with 0.1μF to AGND.
13	AGND		P		Analog ground return.
14	V _A		P		Analog power supply. Bypass voltage source with 4.7μF and pin with 0.1μF to AGND.
15	VREFB	O	A		Bottom of ADC reference. Bypass with a 0.1μF capacitor to ground.
16	VREFT	O	A		Top of ADC reference. Bypass with a 0.1μF capacitor to ground.
17	V _A		P		Analog power supply. Bypass voltage source with 4.7μF and pin with 0.1μF to AGND.
18	AGND		P		Analog ground return.
19	VCLP	IO	A		Input Clamp Voltage. Normally bypassed with a 0.1μF, and a 4.7μF capacitor to AGND. An external reference voltage may be applied to this pin.
20	V _A		P		Analog power supply. Bypass voltage source with 4.7μF and pin with 0.1μF to AGND.
21	IBIAS	O	A		Bias setting pin. Connect a 9.0 kΩ 1% resistor to AGND.
22	AGND		P		Analog ground return.
23	OS _R	I	A		Analog input signal. Typically sensor Red output AC-coupled thru a capacitor.
24	AGND		P		Analog ground return.
25	OS _G	I	A		Analog input signal. Typically sensor Green output AC-coupled thru a capacitor.
26	AGND		P		Analog ground return.
27	OS _B	I	A		Analog input signal. Typically sensor Blue output AC-coupled thru a capacitor.
28	CPOFILT2		A		Charge Pump Filter Capacitor. Bypass this supply pin with a 0.1μF capacitor to CPOFILT1.
29	DGND		P		Digital ground return.
30	CPOFILT1		A		Charge Pump Filter Capacitor. Bypass this supply pin with a 0.1μF capacitor to CPOFILT2.
31	DVB	O	D		Digital Core Voltage bypass. Not an input. Bypass with 0.1μF capacitor to DGND.
32	INCLK+	I	D		Clock Input. When XTALEN=0 Non-Inverting input for LVDS clocks or CMOS clock input. CMOS clock is selected when pin 33 is held at DGND. Otherwise clock is configured for LVDS operation. When XTALEN=1 Connection to terminal 2 of crystal. An 18 pF capacitor should be connected from terminal 1 of the crystal to ground.
33	INCLK-	I	D		Clock Input. When XTALEN=0 Inverting input for LVDS clocks, connect to DGND for CMOS clock. When XTALEN=1 Connection to terminal 1 of crystal. A 18 pF capacitor should be connected from terminal 1 of the crystal to ground.

Pin Functions (continued)

PIN		I/O	TYP	RES	DESCRIPTION
NO.	NAME				
34	DOUT7/ TXCLK+	O	D		Bit 7 of the digital video output bus in CMOS Mode, LVDS Frame Clock+ in LVDS Mode.
35	DOUT6/ TXCLK-	O	D		Bit 6 of the digital video output bus in CMOS Mode, LVDS Frame Clock- in LVDS Mode.
36	DOUT5/ TXOUT2+	O	D		Bit 5 of the digital video output bus in CMOS Mode, LVDS Data Out2+ in LVDS Mode.
37	DOUT4/ TXOUT2-	O	D		Bit 4 of the digital video output bus in CMOS Mode, LVDS Data Out2- in LVDS Mode.
38	DOUT3/ TXOUT1+	O	D		Bit 3 of the digital video output bus in CMOS Mode, LVDS Data Out1+ in LVDS Mode.
39	DOUT2/ TXOUT1-	O	D		Bit 2 of the digital video output bus in CMOS Mode, LVDS Data Out1- in LVDS Mode.
40	DOUT1/ TXOUT0+	O	D		Bit 1 of the digital video output bus in CMOS Mode, LVDS Data Out0+ in LVDS Mode.
41	DOUT0/ TXOUT0-	O	D		Bit 0 of the digital video output bus in CMOS Mode, LVDS Data Out0- in LVDS Mode.
42	DGND	O	p		Digital ground return.
43	V _D		P		Power supply for the digital circuits. Bypass this supply pin with 0.1µF capacitor. A single 4.7µF capacitor should be used between the supply and the VD, VR and VC pins.
44	V _C		P		Power supply for the sensor control outputs. Bypass this supply pin with 0.1µF capacitor.
45	CLKOUT/SH2	O	D		Output clock for registering output data when using CMOS outputs, or a configurable low speed sensor timing output.
46	SH3	O	D		Configurable low speed sensor timing output.
47	RS	O	D		Configurable high speed sensor timing output.
48	CP	O	D		Configurable high speed sensor timing output.
49	PHIA1	O	D		Configurable high speed sensor timing output.
50	PHIA2	O	D		Configurable high speed sensor timing output.
51	DGND		P		Digital ground return.
52	V _C		P		Power supply for the sensor control outputs. Bypass this supply pin with 0.1µF capacitor.
53	PHIB1	O	D		Configurable high speed sensor timing output.
54	PHIB2	O	D		Configurable high speed sensor timing output.
55	SH4	O	D		Configurable low speed sensor timing output.
56	SH5	O	D		Configurable low speed sensor timing output.

6 Specifications

6.1 Absolute Maximum Ratings⁽¹⁾⁽²⁾⁽³⁾

	MIN	MAX	UNIT
Any Positive Supply Voltage (V _A , V _R , V _D , V _C)		4.2	V
Voltage on Any Input or Output Pin (except DVB) (Not to exceed 4.2V)	-0.3	4.2	V
DVB Output Voltage		2.0	V
Input Current at any pin ⁽⁴⁾		±25	mA
Package Input Current ⁽⁴⁾		±50	mA
Package Dissipation at T _A = 25°C ⁽⁵⁾		1.9	W
Soldering Temperature, Infrared, 10 seconds ⁽⁶⁾		235	°C

- (1) Absolute Maximum Ratings indicate limits beyond which damage to the device may occur. Operating Ratings indicate conditions for which the device is functional, but do not ensure specific performance limits. For ensured specifications and test conditions, see the Electrical Characteristics. The ensured specifications apply only for the test conditions listed. Some performance characteristics may degrade when the device is not operated under the listed test conditions. Operation of the device beyond the Operating Ratings is not recommended.
- (2) All voltages are measured with respect to A_{GND} = D_{GND} = 0V, unless otherwise specified.
- (3) If Military/Aerospace specified devices are required, please contact the Texas Instruments Sales Office/ Distributors for availability and specifications.
- (4) When the input voltage (V_{IN}) at any pin exceeds the power supplies (V_{IN} < GND or V_{IN} > V_A or V_D), the current at that pin should be limited to 25 mA. The 50 mA maximum package input current rating limits the number of pins that can simultaneously safely exceed the power supplies with an input current of 25 mA to two.
- (5) The absolute maximum junction temperature (T_{JMAX}) for this device is 150°C. The maximum allowable power dissipation is dictated by T_{JMAX}, the junction to ambient thermal resistance (R_{θJA}), and the ambient temperature (T_A), and can be calculated using the formula P_{DMAX} = (T_{JMAX} - T_A)/R_{θJA}. The values for maximum power dissipation listed will be reached only when the LM98725 is operated in a severe faulty condition.
- (6) See AN450, "Surface Mounting Methods and Their Effect on Product Reliability", or the section entitled "Surface Mount" found in any post 1986 Texas Instruments Semiconductor Linear Data Book, for other methods of soldering surface mount devices.

6.2 Handling Ratings

	MIN	MAX	UNIT
T _{stg} Storage temperature range	-65	+150	°C
V _(ESD) Electrostatic discharge ⁽¹⁾	Human body model (HBM), per ANSI/ESDA/JEDEC JS-001, all pins ⁽²⁾		V
	Charged device model (CDM), per JEDEC specification JESD22-C101, all pins ⁽³⁾		

- (1) Human body model is 100 pF capacitor discharged through a 1.5-kΩ resistor. Machine model is 220-pF discharged through 0Ω.
- (2) JEDEC document JEP155 states that 2500-V HBM allows safe manufacturing with a standard ESD control process.
- (3) JEDEC document JEP157 states that 250-V CDM allows safe manufacturing with a standard ESD control process.

6.3 Recommended Operating Conditions⁽¹⁾⁽²⁾

	MIN	MAX	UNIT
Operating Temperature Range	0 ≤ T _A ≤ +70		°C
All Supply Voltage	+3.0	+3.6	V

- (1) Absolute Maximum Ratings indicate limits beyond which damage to the device may occur. Operating Ratings indicate conditions for which the device is functional, but do not ensure specific performance limits. For ensured specifications and test conditions, see the Electrical Characteristics. The ensured specifications apply only for the test conditions listed. Some performance characteristics may degrade when the device is not operated under the listed test conditions. Operation of the device beyond the Operating Ratings is not recommended.
- (2) All voltages are measured with respect to A_{GND} = D_{GND} = 0V, unless otherwise specified.

6.4 Electrical Characteristics

The following specifications apply for $V_A = V_D = V_R = V_C = 3.3\text{ V}$, $C_L = 10\text{ pF}$, and $f_{\text{INCLK}} = 27\text{ MHz}$ unless otherwise specified. all other limits $T_A = 25^\circ\text{C}$.⁽¹⁾

PARAMETER		TEST CONDITIONS	MIN ⁽²⁾	TYP ⁽³⁾	MAX ⁽²⁾	UNIT
CMOS DIGITAL INPUT DC SPECIFICATIONS (RESETb, SH_R, SCLK, SENb)						
V_{IH}	Logical "1" Input Voltage		2.0			V
V_{IL}	Logical "0" Input Voltage				0.8	V
V_{IHYST}	Logic Input Hysteresis			0.6		V
I_{IH}	Logical "1" Input Current	$V_{IH} = V_D$:				
		RESET, SEN		100		nA
		SH_R, SCLK, SDI, CAL		65		μA
		CE		30		μA
I_{IL}	Logical "0" Input Current	$V_{IL} = \text{DGND}$:				
		RESET, SEN		-65		μA
		SH_R, SCLK, SDI, CAL		-100		nA
		CE		-30		μA
CMOS DIGITAL OUTPUT DC SPECIFICATIONS (SH1 to SH5, RS, CP, PHIA, PHIB, PHIC)						
V_{OH}	Logical "1" Output Voltage	$I_{OUT} = -0.5\text{ mA}$	3.0			V
V_{OL}	Logical "0" Output Voltage	$I_{OUT} = 1.6\text{ mA}$			0.21	V
I_{OS}	Output Short Circuit Current	$V_{OUT} = \text{DGND}$		18		mA
		$V_{OUT} = V_D$		-25		
I_{OZ}	CMOS Output TRI-STATE Current	$V_{OUT} = \text{DGND}$		20		nA
		$V_{OUT} = V_D$		-25		
CMOS DIGITAL OUTPUT DC SPECIFICATIONS (CMOS DATA OUTPUTS)						
V_{OH}	Logical "1" Output Voltage	$I_{OUT} = -0.5\text{ mA}$		2.3		V
V_{OL}	Logical "0" Output Voltage	$I_{OUT} = 1.6\text{ mA}$		0.12		V
I_{OS}	Output Short Circuit Current	$V_{OUT} = \text{DGND}$		12		mA
		$V_{OUT} = V_D$		-14		
I_{OZ}	CMOS Output TRI-STATE Current	$V_{OUT} = \text{DGND}$		20		nA
		$V_{OUT} = V_D$		-25		
LVDS/CMOS CLOCK RECEIVER DC SPECIFICATIONS (INCLK+ and INCLK-PINS)						
V_{IHL}	Differential LVDS Clock High Threshold Voltage	$R_L = 100\ \Omega$ V_{CM} (LVDS Input Common Mode Voltage) = 1.25 V			200	mV
V_{ILL}	Differential LVDS Clock Low Threshold Voltage			-200		mV
V_{IHC}	CMOS Clock High Threshold Voltage	INCLK- = DGND		2.0		V
V_{ILC}	CMOS Clock Low Threshold Voltage				0.8	V
I_{IHL}	CMOS Clock Input High Current			230	260	μA
I_{ILC}	CMOS Clock Input Low Current		-135	-120		μA

- (1) The analog inputs are protected as shown in Figure 2. Input voltage magnitudes beyond the supply rails will not damage the device, provided the current is limited per Note 4 under the Absolute Maximum Ratings Table. However, input errors will be generated if the input goes above V_A and below AGND.
- (2) Test limits are specified to Texas Instruments' AOQL (Average Outgoing Quality Level).
- (3) Typical figures are at $T_A = 25^\circ\text{C}$, and represent most likely parametric norms at the time of product characterization. The typical specifications are not ensured.

Electrical Characteristics (continued)

The following specifications apply for $V_A = V_D = V_R = V_C = 3.3\text{ V}$, $C_L = 10\text{ pF}$, and $f_{\text{INCLK}} = 27\text{ MHz}$ unless otherwise specified. All other limits $T_A = 25^\circ\text{C}$.⁽¹⁾

PARAMETER		TEST CONDITIONS	MIN ⁽²⁾	TYP ⁽³⁾	MAX ⁽²⁾	UNIT
LVDS OUTPUT DC SPECIFICATIONS						
V_{OD}	Differential Output Voltage	$R_L = 100\ \Omega$	280	390	490	mV
V_{OS}	LVDS Output Offset Voltage		1.08	1.20	1.33	V
I_{OS}	Output Short Circuit Current	$V_{\text{OUT}} = 0\text{ V}$, $R_L = 100\ \Omega$		8.5		mA
POWER SUPPLY SPECIFICATIONS						
I_A	VA Analog Supply Current	LVDS Output Data Format		152	180	mA
		LVDS Output Data Format (Powerdown)		3.6	6	mA
		CMOS Output Data Format (40 MHz)		136	168	mA
I_D	VD Digital Output Driver Supply Current	LVDS Output Data Format		76	94	mA
		LVDS Output Data Format (Powerdown)		8.5	17	mA
		CMOS Output Data Format (ATE Loading of CMOS Outputs > 50 pF) (40 MHz)		46	68	mA
I_C	VC CCD Timing Generator Output Driver Supply Current	Typical sensor outputs: SH1-SH5, PHIA, PHIB, PHIC, RS, CP (ATE Loading of CMOS Outputs > 50 pF)		1	4	mA
PWR	Average Power Dissipation	LVDS Output Data Format		755	885	mW
		LVDS Output Data Format (Powerdown)		40	70	mW
		CMOS Output Data Format (ATE Loading of CMOS Outputs > 50 pF) (40 MHz)		600	740	mW
INPUT SAMPLING CIRCUIT SPECIFICATIONS						
V_{IN}	Input Voltage Level	CDS Gain=1x, PGA Gain=1x		2.3		Vp-p
		CDS Gain=2x, PGA Gain= 1x		1.22		
$I_{\text{IN_SH}}$	Sample and Hold Mode Input Leakage Current ($V_{\text{clamp}} = \text{Default} = 2.6\text{ V}$)	Source Followers Off CDS/SH Gain = 1x $OS_X = V_A$ ($OS_X = \text{AGND}$)	(-200)	32 (-165)	50	μA
		Source Followers Off CDS/SH Gain = 2x $OS_X = V_A$ ($OS_X = \text{AGND}$)	(-290)	55 (-240)	70	μA
		Source Followers On CDS/SH Gain = 2x $OS_X = V_A$ ($OS_X = \text{AGND}$)	(-250)	20 (-50)	250	nA
C_{SH}	Sample/Hold Mode Equivalent Input Capacitance (see Figure 12)	CDS Gain = 1x		2.5		pF
		CDS Gain = 2x		4		pF
$I_{\text{IN_CDS}}$	CDS Mode Input Leakage Current	Source Followers Off $OS_X = V_A$ ($OS_X = \text{AGND}$)	(-250)	10 (-50)	250	nA
R_{CLPIN}	CLPIN Switch Resistance (OS_X to VCLP Node in Figure 9)			16	55	Ω

Electrical Characteristics (continued)

The following specifications apply for $V_A = V_D = V_R = V_C = 3.3\text{ V}$, $C_L = 10\text{ pF}$, and $f_{\text{INCLK}} = 27\text{ MHz}$ unless otherwise specified. all other limits $T_A = 25^\circ\text{C}$.⁽¹⁾

PARAMETER		TEST CONDITIONS	MIN ⁽²⁾	TYP ⁽³⁾	MAX ⁽²⁾	UNIT
VCLP REFERENCE CIRCUIT SPECIFICATIONS						
V_{VCLP}	VCLP Voltage 000	VCLP Voltage Setting = 000		0.85VA		V
	VCLP Voltage 001	VCLP Voltage Setting = 001		0.9VA		V
	VCLP Voltage 010	VCLP Voltage Setting = 010		0.95VA		V
	VCLP Voltage 011	VCLP Voltage Setting = 011		0.6VA		V
	VCLP Voltage 100	VCLP Voltage Setting = 100		0.55VA		V
	VCLP Voltage 101	VCLP Voltage Setting = 101		0.4VA		V
	VCLP Voltage 110	VCLP Voltage Setting = 110		0.35VA		V
	VCLP Voltage 111	VCLP Voltage Setting = 111		0.15VA		V
I_{SC}	VCLP DAC Short Circuit Output Current			30		mA
BLACK LEVEL OFFSET DAC SPECIFICATIONS						
	Resolution			10		Bits
	Monotonicity			Ensured by characterization		
	Offset Adjustment Range Referred to AFE Input	CDS Gain = 1x				mV
		Minimum DAC Code = 0x000		-614		
		Maximum DAC Code = 0x3FF		614		
	Offset Adjustment Range Referred to AFE Output	CDS Gain = 2x				mV
		Minimum DAC Code = 0x000		-307		
		Maximum DAC Code = 0x3FF		307		
	Offset Adjustment Range Referred to AFE Output	Minimum DAC Code = 0x000	-17500		-16130	LSB
		Maximum DAC Code = 0x3FF	+16130		+17500	
	DAC LSB Step Size	CDS Gain = 1x Referred to AFE Output		1.2		mV
				(32)		(LSB)
DNL	Differential Non-Linearity		-0.84	+0.74/ -0.37	+2.4	LSB
INL	Integral Non-Linearity		-2.5	+0.72/ -0.56	+2.5	LSB
PGA SPECIFICATIONS						
	Gain Resolution			8		Bits
	Monotonicity			Ensured by characterization		
	Maximum Gain	CDS Gain = 1x	7.7	8.3	8.8	V/V
		CDS Gain = 1x	17.7	18.4	18.9	dB
	Minimum Gain	CDS Gain = 1x	0.58	0.62	0.67	V/V
		CDS Gain = 1x	-4.7	-4.2	-3.5	dB
	PGA Function	Gain (V/V) = (180/(277-PGA Code)) Gain (dB) = 20LOG10(180/(277-PGA Code))				
	Channel Matching	Minimum PGA Gain		3%		
		Maximum PGA Gain		12.7%		

Electrical Characteristics (continued)

The following specifications apply for $V_A = V_D = V_R = V_C = 3.3\text{ V}$, $C_L = 10\text{ pF}$, and $f_{\text{INCLK}} = 27\text{ MHz}$ unless otherwise specified. all other limits $T_A = 25^\circ\text{C}$.⁽¹⁾

PARAMETER		TEST CONDITIONS	MIN ⁽²⁾	TYP ⁽³⁾	MAX ⁽²⁾	UNIT
ADC SPECIFICATIONS						
V_{REFT}	Top of Reference			2.07		V
V_{REFB}	Bottom of Reference			0.89		V
$V_{\text{REFT}} - V_{\text{REFB}}$	Differential Reference Voltage		1.06	1.18	1.30	V
	Over range Output Code			65535		
	Under range Output Code			0		
DIGITAL OFFSET "DAC" SPECIFICATIONS						
	Resolution			7		Bits
	Digital Offset DAC LSB Step Size	Referred to AFE Output		32		LSB
	Offset Adjustment Range Referred to AFE Output	Min DAC Code = 7'b0000000		-2048		LSB
		Mid DAC Code = 7'b1000000		0		
		Max DAC Code = 7'b1111111		+2016		
FULL CHANNEL PERFORMANCE SPECIFICATIONS						
DNL	Differential Non-Linearity	See ⁽⁴⁾	-0.999	+0.8/ -0.7	2.5	LSB
INL	Integral Non-Linearity	See ⁽⁴⁾	-75	+18/ -25	75	LSB
SNR	Total Output Noise	Minimum PGA Gain ⁽⁴⁾		-76		dB
				10	26	LSB RMS
		Maximum PGA Gain ⁽⁴⁾		-56		dB
				96		LSB RMS
	Channel to Channel Crosstalk	Mode 3		26		LSB
		Mode 2		17		

(4) This parameter ensured by design and characterization.

6.5 AC Timing Specifications

The following specifications apply for $V_A = V_D = V_R = V_C = 3.3\text{ V}$, $C_L = 10\text{ pF}$, and $f_{\text{INCLK}} = 27\text{ MHz}$ unless otherwise specified. All other limits $T_A = 25^\circ\text{C}$.⁽¹⁾

PARAMETER		TEST CONDITIONS	MIN ⁽²⁾	TYP ⁽³⁾	MAX ⁽²⁾	UNIT
INPUT CLOCK TIMING SPECIFICATIONS						
f_{INCLK}	Input Clock Frequency	INCLK = PIXCLK (Pixel Rate Clock)	0.66		27 (Mode 3)	MHz
			1		30 (Mode 2)	
			1		30 (Mode 1)	
		INCLK = ADCCLK (ADC Rate Clock)	2		81 (Mode 3)	MHz
			2		60 (Mode 2)	
			2		30 (Mode 1)	
T_{dc}	Input Clock Duty Cycle		40/60%	50/50%	60/40%	
FULL CHANNEL LATENCY SPECIFICATIONS						
t_{LAT3}	3 Channel Mode Pipeline Delay	PIXPHASE0		24		T_{ADC}
	Figure 54 (LVDS)	PIXPHASE1		23.5		
	Figure 59 (CMOS)	PIXPHASE2		23		
		PIXPHASE3		22.5		
t_{LAT2}	2 Channel Mode Pipeline Delay	PIXPHASE0		21		T_{ADC}
	Figure 55 (LVDS)	PIXPHASE1		20.5		
	Figure 60 (CMOS)	PIXPHASE2		20		
		PIXPHASE3		19.5		
t_{LAT1}	1 Channel Mode Pipeline Delay	PIXPHASE0		19		T_{ADC}
	Figure 56 (LVDS)	PIXPHASE1		18.5		
	Figure 61 (CMOS)	PIXPHASE2		18		
		PIXPHASE3		17.5		

- (1) The analog inputs are protected as shown in [Figure 2](#). Input voltage magnitudes beyond the supply rails will not damage the device, provided the current is limited per [Note 4](#) under the Absolute Maximum Ratings Table. However, input errors will be generated if the input goes above V_A and below AGND.
- (2) Test limits are specified to AOQL (Average Outgoing Quality Level).
- (3) Typical figures are at $T_A = 25^\circ\text{C}$, and represent most likely parametric norms at the time of product characterization. The typical specifications are not ensured.

AC Timing Specifications (continued)

The following specifications apply for $V_A = V_D = V_R = V_C = 3.3\text{ V}$, $C_L = 10\text{ pF}$, and $f_{\text{INCLK}} = 27\text{ MHz}$ unless otherwise specified. All other limits $T_A = 25^\circ\text{C}$.⁽¹⁾

PARAMETER		TEST CONDITIONS	MIN ⁽²⁾	TYP ⁽³⁾	MAX ⁽²⁾	UNIT
SH_R TIMING SPECIFICATIONS (Figure 44)						
t_{SHR_S}	SH_R Setup Time			2		ns
t_{SHR_H}	SH_R Hold Time			2		ns
LVDS OUTPUT TIMING SPECIFICATIONS (Figure 53)						
$\text{TX}_{\text{pp}0}$	TXCLK to Pulse Position 0		-0.26	0	0.26	ns
$\text{TX}_{\text{pp}1}$	TXCLK to Pulse Position 1		1.50	1.76	2.02	ns
$\text{TX}_{\text{pp}2}$	TXCLK to Pulse Position 2		3.26	3.53	3.79	ns
$\text{TX}_{\text{pp}3}$	TXCLK to Pulse Position 3		5.03	5.29	5.55	ns
$\text{TX}_{\text{pp}4}$	TXCLK to Pulse Position 4		6.80	7.06	7.32	ns
$\text{TX}_{\text{pp}5}$	TXCLK to Pulse Position 5		8.56	8.82	9.08	ns
$\text{TX}_{\text{pp}6}$	TXCLK to Pulse Position 6		10.32	10.58	10.84	ns
CMOS OUTPUT TIMING SPECIFICATIONS						
t_{CRDO}	CLKOUT Rising Edge to CMOS Output Data Transition	$f_{\text{INCLK}} = 40\text{ MHz}$, INCLK = ADCCLK (ADC Rate Clock)	2	4.5	9	ns
SERIAL INTERFACE TIMING SPECIFICATIONS						
f_{SCLK}	Input Clock Frequency	$f_{\text{SCLK}} \leq f_{\text{INCLK}}$, INCLK = PIXCLK (Pixel Rate Clock) Mode 3/2/1			27/30/30	MHz
		$f_{\text{SCLK}} \leq f_{\text{INCLK}}$, INCLK = ADCCLK (ADC Rate Clock) Mode 3/2/1			81/60/30	MHz
	SCLK Duty Cycle			50/50		ns
t_{IH}	Input Hold Time		1.5			ns
t_{IS}	Input Setup Time		2.5			ns
t_{SENSC}	SCLK Start Time after $\overline{\text{SEN}}$ Low		1.5			ns
t_{SCSEN}	$\overline{\text{SEN}}$ High after last SCLK Rising Edge		2.5			ns
t_{SEnw}	$\overline{\text{SEN}}$ Pulse Width	INCLK present ⁽⁴⁾⁽⁵⁾	6			T_{INCLK}
		INCLK stopped ⁽⁴⁾⁽⁵⁾	50			ns
t_{OD}	Output Delay Time			11	14	ns
t_{HZ}	Data Output to High Z				0.5	T_{SCLK}

(4) If the input INCLK is divided down to a lower internal clock rate via the PLL, the parameter t_{SEnw} will be increased by the same factor.

(5) When the Spread Spectrum Clock Generation feature is enabled, t_{SEnw} should be increased by 1.

7 Detailed Description

7.1 Overview

The LM98725 is a 16-bit, three-input, complete Analog Front End (AFE) for digital color copier and Multi-Function Peripheral (MFP) applications. The system block diagram of the LM98725, shown in [LM98725 Overall Chip Block Diagram](#) highlights the main features of the device. Each input has its own Input Bias and Clamping Network which are routed through a selectable Sample/Hold (S/H) or Correlated Double Sampler (CDS) amplifier. A ± 9 -Bit Offset DAC applies independent offset correction for each channel. A -3 to 17.9dB Programmable Gain Amplifier (PGA) applies independent gain correction for each channel. The LM98725 also provides independent Digital Black Level Correction Feedback Loops for each channel. The Black Level Correction Loop can be configured to run in Manual Mode (where the user inputs their own values of DAC offset) or in Automatic Mode where the LM98725 calculates each channel's Offset DAC value during optical black pixels and then adjusts the Offset register accordingly. The signals are routed to a single high performance 16-bit, 81MHz analog-to-digital converter.

The analog inputs are protected as shown in [Figure 2](#). Input voltage magnitude up to 500 mV beyond the supply rails will not damage this device. However, input errors will be generated if the input goes above VA and below AGND.

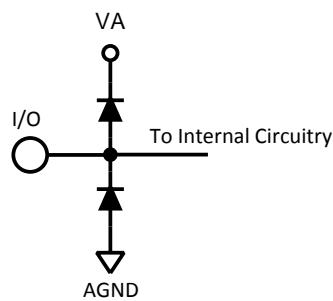

Figure 2. Analog Input Protection

7.2 Functional Block Diagrams

7.2.1 LM98725 Overall Chip Block Diagram

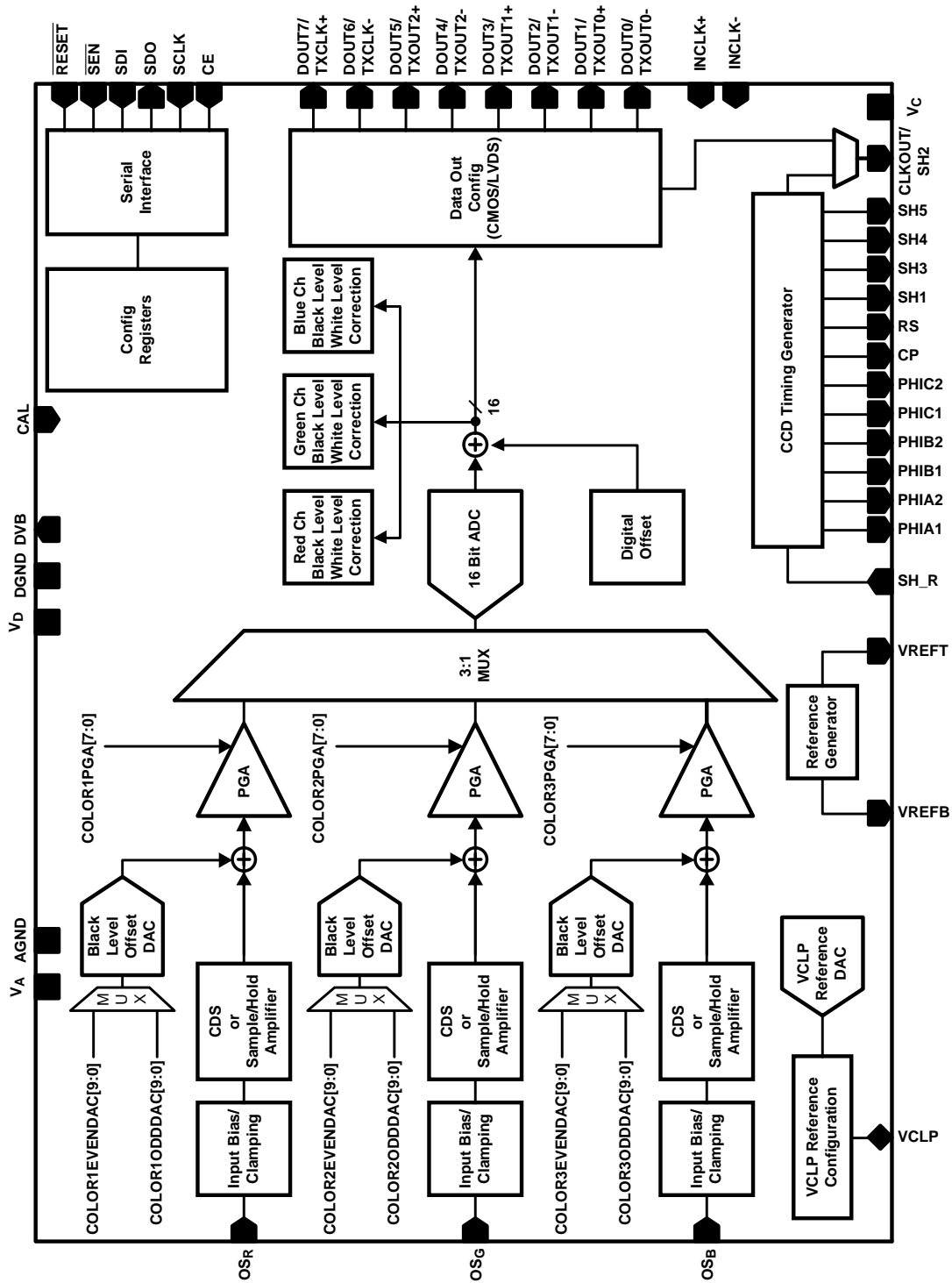

Figure 3. Chip Block Diagram

Functional Block Diagrams (continued)

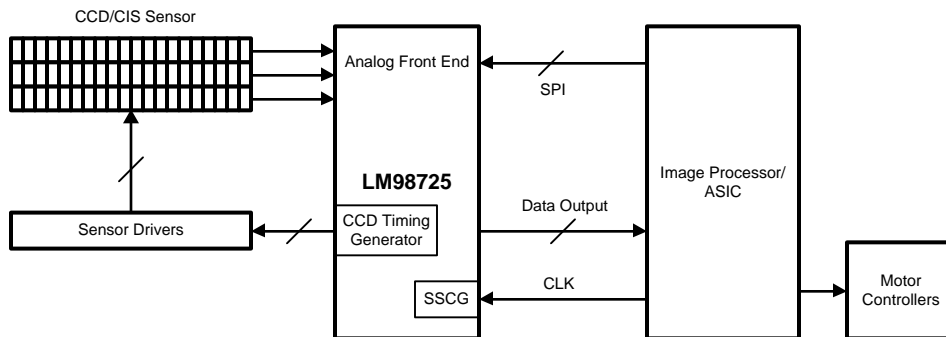

Figure 4. System Block Diagram

7.3 Feature Description

7.3.1 Modes of Operation Introduction

The LM98725 can be configured to operate in several different operating modes. The following sections are a brief introduction to these modes of operation. A more rigorous explanation of the operating modes is contained in the [Device Functional Modes](#) section, including input sampling diagrams for each mode as well as a description of the operating conditions.

7.3.2 Mode 3 - Three Channel Input/Synchronous Pixel Sampling

OS_B , OS_G , and OS_R inputs are sampled synchronously at a pixel rate. The sampled signals are processed with each channel's offset and gain adjusted independently via the control registers. The order in which pixels are processed from the input to the ADC is fully programmable and is synchronized by the SH pulse. In this mode, the maximum channel speed is 27MSPS per channel with the ADC running at 81MSPS yielding a three color throughput of 81MSPS.

7.3.3 Mode 2 - Two Channel Input/Synchronous Pixel Sampling

Mode 2 is useful for CCD sensors with a Black and White mode with Even and Odd outputs. In its default configuration, Mode 2 samples the Even output via the OS_B channel input, and the Odd output via the OS_G channel input. Sampling of the Even and Odd pixels is performed synchronously at a maximum sample rate of 30MSPS per input with the ADC running at 60MSPS.

7.3.4 Mode 1 - One Channel Input

In Mode 1, all pixels are processed through a single input (OS_R , OS_G , or OS_B) chosen through the control register setup. This mode is useful in applications where only one input channel is used. The selected input is programmable through the control register.

7.3.5 CIS Lamp and Coefficient Modes

In addition to Modes 3, 2, and 1 above, two different CIS sensor modes (CISa and CISb) can be enabled. These allow color sequential lamp control, as well as synchronized color sequential gain/offset coefficient usage for multi-output color sequential sensors.

7.3.6 Clock Sources

7.3.6.1 User Provided Clock Signal

When $XTALEN = 0$ (Page 0, Register 0, Bit 2) the clock input to the LM98725 can be a differential LVDS clock on the INCLK+ and INCLK- pins or a CMOS level clock applied to the INCLK+ pin with the INCLK- pin connected to DGND. The external clock signal format is auto sensed internally.

Feature Description (continued)

7.3.6.2 Crystal Oscillator Driver On-Chip

When XTALEN = 1 (Page 0, Register 0, Bit 2), an on-chip crystal oscillator driver circuit can be paired with an external crystal. Terminal 2 of the crystal should connect to INCLK+ and terminal 1 of the crystal should connect to INCLK-. 18 pF capacitors should connect from each terminal of the crystal to ground.

7.3.6.3 Clock Multiplication - Basic

For any of the available clock sources, the input clock can be applied at the Pixel frequency (PIXCLK) or at the ADC frequency (ADCCLK). The LM98725 can perform internal clock multiplication when a Pixel frequency clock is applied, or no multiplication when an ADC frequency clock is applied. The internal configuration registers need to be written to perform the proper setup of the input clock. The available input clock configurations for each operating mode are outlined in [Table 1](#).

Table 1. Input Clock Configurations for Operating Modes

AFE MODE	INPUT CLOCK TYPE	INTERNAL MULTIPLIER	INCLK MAX FREQ.	CONFIGURATION REGISTER SETTINGS
Mode 3	INCLK = Pixel Freq. (PIXCLK) INCLK = ADC Freq. (ADCCLK)	3x 1x	27MHz 81MHz	TBD TBD
Mode 2	INCLK = Pixel Freq. (PIXCLK) INCLK = ADC Freq. (ADCCLK)	2x 1x	30MHz 60MHz	TBD TBD
Mode 1	INCLK = Pixel Freq. = ADC Freq. (ADCCLK = PIXCLK in Mode 1)	1x	30MHz	TBD

7.3.6.4 Clock Multiplication - Flexible

There are a variety of situations where it is desirable to multiply the base frequency by a selected amount to achieve the proper pixel frequency for a given application and set of system conditions.

- Applications using the onchip Crystal Oscillator driver will have much more flexibility of pixel frequencies.
- Reducing the input MCLK frequency can significantly reduce the EMI generated by the MCLK signals being sent up the cable from the host board to the imaging board.

To ease this task a flexible multiplying PLL architecture is incorporated. When the 2 PLL architecture is enabled (Page 2, Register 0x1Bh, Bit 1=0) the source clock frequency is multiplied by the ratio M/N. Two registers are used to set these values:

$$M = \text{Value}(\text{Page 2, Register 0x1Ch}) + 1$$

$$N = \text{Value}(\text{Page 2, Register 0x1Dh}) + 1$$

$$N(\text{max}) = 64$$

$$M/N(\text{max}) = 64$$

$$M/N(\text{min}) = 1/64$$

Note: Since the 8 bit register values can be from 0 to 255, the resulting Numerator and Denominator values could be from 1 to 256. However, the maximum recommended multiply or divide ratios are 64x or x/64. In addition, the maximum recommended value for N is 64.

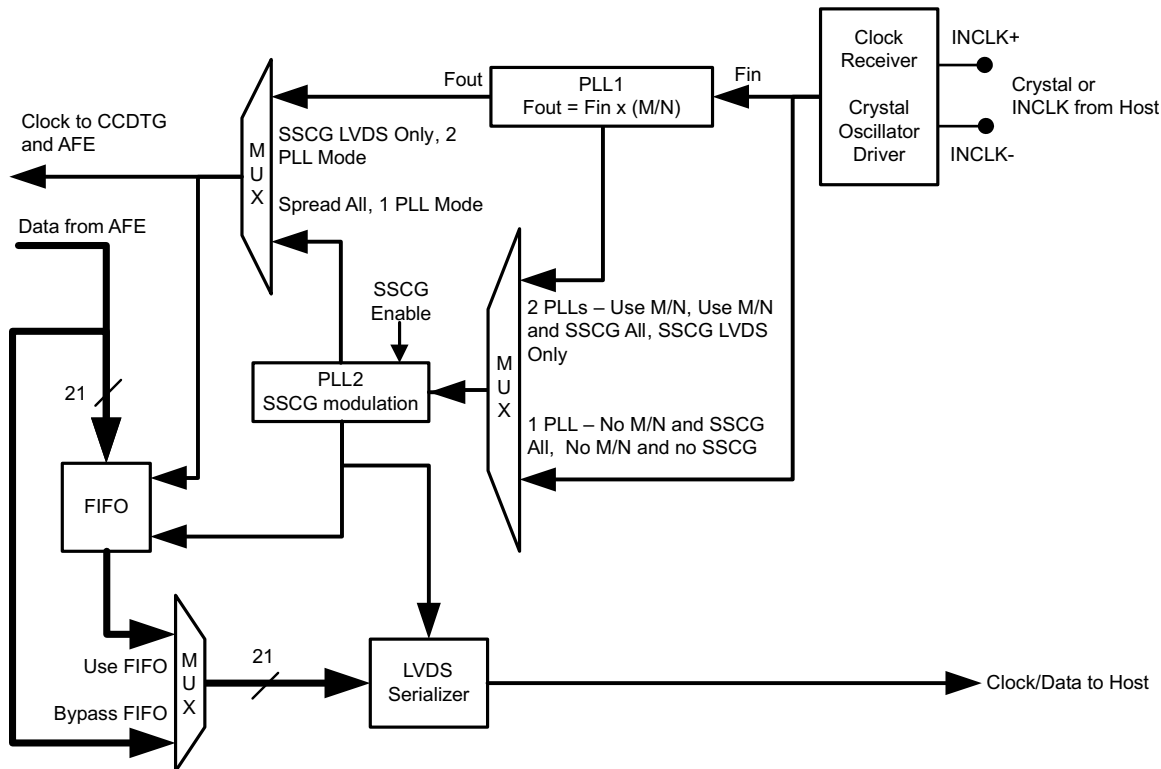
Clock System Configuration Options

Source	PLL (Dual/Single)	Spreading (On/Off)	SpreadMode (LVDS/All)
INCLK	Single	ON	ALL
INCLK	Single	OFF	N/A
INCLK	Dual (Use M/N)	ON	LVDS*
INCLK	Dual (Use M/N)	ON	ALL
INCLK	Dual (Use M/N)	OFF	N/A
XTAL	Single	ON	ALL
XTAL	Single	OFF	N/A
XTAL	Dual (Use M/N)	ON	LVDS*
XTAL	Dual (Use M/N)	ON	ALL
XTAL	Dual (Use M/N)	OFF	N/A

*If SpreadMode is LVDS, then FIFO is used to move data from CCDTG/AFE clock domain to LVDS clock domain.

Figure 5. Clock System Block Diagram

7.3.7 Clock Sources - Additional Settings and Flexibility

To support the new crystal oscillator feature, some additional flexibility was added. In Crystal Oscillator mode, the master clock source is now on the AFE (rather than in the system ASIC or main processor). If Slave Timing Mode (see [CCD Timing Generator Master/Slave Modes](#)) is still needed (to synchronize the AFE to the line timing of the system), the external SH_R signal must now be captured with the internal clock source. The SH_R Capture Clock Select bit has been added to support this case.

In addition, in these systems, it may be difficult to adjust the host SH_R timing to get the best Setup and Hold times with respect to the internal CLK. The SH_R, INCLK Monitor Override and SH_R Capture Edge Select controls have been added to support these needs. The INCLK Monitor Override allows the internal SH_R and CLK signals to be monitored, to aid in selected the best edge (rising or falling) of CLK to latch the SH_R signal.

- SH_R Capture Clock Select (Page 0, Register 0x00, Bit 5)
 - 0 - Use internal INCLK source to latch SH_R
 - 1 - Use external CLK source to latch SH_R
- SH_R Capture Edge Select (Page 0, Register 0x00, Bit 4)

- 0 - Use rising edge of selected clock source
- 1 - Use falling edge of selected clock source
- SH_R and INCLK Monitor Override (Page 0, Register 0x14, Bit 6)
 - 0 - Timing monitor selections unaltered
 - 1 - Timing monitors for CLAMPB and SAMPB are replaced with monitor of SH_R_Internal and SH_R_Capture_Clock_Internal.

7.3.8 Spread Spectrum Clock Generation (SSCG)

NOTE

When using SSCG, ensure that INCLK = ADCCLK is selected at Page 0, Register 0x02, Bit 2 = 0. Then set the flexible clock multiplication PLL settings to achieve the desired internal clock frequency from the applied clock.

EMI is a problem faced by any system designer. In a typical imaging system, data must be sent over a relatively long cable to the main system board. To minimize the amount of measured EMI caused by system clocking and data transmission, a flexible Spread Spectrum Clock Generation system is included in the LM98725.

The spread spectrum feature is configured by the registers at Page 2, Registers 0x1Ah, 0x1Bh and 0x1Eh.

The following key SSCG modes of operation and features are provided:

- Spread output data/clock only (Internal FIFO used to transfer data between clock domains) or spread internal system clock as well as output data/clock
- Spread synchronized to CCD line length (SH period or frequency) or unsynchronized.
- Spread widths of 0.625, 1.25, 2.5 and 5 % selectable
- Spread gain of 1x to 2x can double the selected spread widths
- 3 selectable modulation frequency multipliers to increase the spreading modulation frequency
- Spread “boost” provides a cleaner spread for 1 channel and 2 channel modes of AFE operation.
- Spread MaxRate allows the most effective spreading modulation for Output Only spreading. When this bit is set, the spreading waveform is NOT synchronized to the CCD line timing.
- Spreading modulation waveform and FIFO reset by SH_R event. (Page 8, Register 0x1Eh, Bit 7) This ensures that the spreading waveform is synchronized to the CCD line timing, even if SH_R to SH_R period is varied by system ASIC.
- Spreading SH_R Reset can be delayed from SH_R event by a “Holldoff” amount. (Page 8, Register 0x1Eh, Bits6:0)

7.3.9 Typical EMI Cases and Recommended SSCG Settings

- **Case 1: Majority of EMI coming from LVDS outputs**
 - **Usage:** Spread output data/clock only. FIFO used to move data between non-spread and spread clock domains. If Slave Mode is also used, ensure that the Line Length and Line Length Multiplier settings correspond to the SH_R period. If the SH_R period may vary, then set FIFO Reset (Page 2, Register 0x1Bh, Bit 6 =1) to ensure the FIFO counters are reset every SH Interval.
- **Case 2: EMI from LVDS outputs and CCD timing signals - Master Mode Application**
 - **Usage:** Spread internal system clock as well as output data/clock. Synchronize spread waveform to SH Interval. Best to use Master mode timing to ensure spread waveform is always smoothly synchronized to the SH Interval timing.
- **Case 3: EMI from LVDS outputs and CCD timing signals - Slave Mode Application**
 - **Usage:** Spread internal system clock as well as output data/clock. Use minimal amount of spreading to reduce CCD timing emissions, in combination with data scrambling to further reduce data cable emissions. The small amount of spreading minimizes effects on image data, therefore, spreading is not required to be synchronized with SH Intervals.

7.3.10 Recommended Master/Slave, Clock Source and SSCG Combinations and Settings

7.3.10.1 Master Mode Operation (LM98725 Controls Line Timing)

(These are easiest cases to implement SSCG)

Clock from host board

1. Use SSCG - Spread All
2. Use SSCG - Spread LVDS Only
3. No SSCG

Clock from local crystal

1. Use SSCG - Spread All
2. Use SSCG - Spread LVDS Only
3. No SSCG

7.3.10.2 Slave Mode Operation (Host FPGA or ASIC Controls Line Timing)

NOTE: These SSCG cases are more challenging as received LVDS data timing will not be synchronous with the clock of the FPGA/ASIC. Clock from host board. If a local clock is present on the FPGA/ASIC, an internal FIFO must be implemented to transfer the received data from the spread LVDS clock domain, to the internal FPGA/ASIC clock domain. If the AFE LVDS clock is used as the system clock, care must be taken to ensure that settings are not loaded which disable this clock, and therefore lock up the system.)

1. Use SSCG - Spread All - Need spreading start to be SH gated, and SH period to be consistent to ensure consistent capture of SH_R by the spread INCLK.
2. Use SSCG - Spread LVDS Only - In this case ensure that Line Length Register is set to same number of pixels as that of SH_R period. In addition, if SH_R period will vary, set FIFO Reset (Page 2, Register 0x1Bh, Bit 6 = 1) to reset FIFO at SH Interval.
3. No SSCG

Clock from local crystal (Not recommended, difficult to meet CLK to SH_R setup and hold times. Use Master Mode instead)

1. Use SSCG - Spread All
2. Use SSCG - Spread LVDS Only
3. No SSCG

7.3.10.3 SSCG Configuration/Usage Flow

- Unlock Registers (Page 0, Register 0, Bit 0 = 0)
- Ensure PIXCLK/ADCCLK Configuration is set to ADCCLK. Page 0, Register 0x02, Bit 2 = 0.
- Set Override PLL2 Lock Detector (Page 2, Register 0x1B, Bit 4) = 1
- Set PLL2 Charge Pump Current Control (Page 2, Register 0x19, Bits 4:3) = 00
- Set PLL2 Filter Bandwidth Control (Page 2, Register 0x19, Bits 2:0) = 111
- Set SSCG Spread Boost (Page 2, Register 0x1A, Bit 5) = 0 or 1 (0 = default, recommended for most applications)
- Set SSCG Spread Gain (Page 2, Register 0x1A, Bit 4) = 0 or 1 (0 = default, recommended for most applications)
- Set SSCG Spread Width (Page 2, Register 0x1A, Bits 3:2) = 0.625% to 2.5% (Beyond 2.5% most LVDS deserializers will not track the clock properly)
- Set SSCG SH Sync Enable (Page 2, Register 0x1A, Bit 1) = 0 or 1 (Set to 1 for Spread All)
- Set PLL Mode Select (Page 2, Register 0x1B, Bits 1:0) = 00, 01 or 11. Spread Output Only or Spread All Clocks
- If PLL Clock Multiplication Enabled, Set Clock Mult M (Page 2, Register 0x1C) and N (Page 2, Register 0x1D) to desired values. If a pixel rate clock is applied, set the PLL multiplication to the same factor as the AFE Mode selected at Page 0, Register 0x03, Bits 7:6. ie. The multiplication factor should be 3x for Mode 3, 2x for Mode 2 and 1x for Mode 1.

- Set SSCG Enable (Page 2, Register 0x1A, Bit 0) = 1 (enable spreading, load spreading state machines)
- Lock Registers (Page 0, Register 0, Bit 0 = 1)
- If spreading is synchronized to SH interval, the spreading function will wait until the next SH Interval before beginning.
- Set SSCG Enable (Page 2, Register 0x1A, Bit 0) = 1 (enable spreading, load spreading state machines)
- Lock Registers (Page 0, Register 0, Bit 0 = 1)
- If spreading is synchronized to SH interval, the spreading function will wait until the next SH Interval before beginning.

7.3.10.4 Changing SSCG Settings

To Change SSCG Settings:

- Un-Lock Registers ((Page 0, Register 0, Bit 0 = 0)
- Set SSCG Enable = 0 (disable spreading)
- Change desired SSCG settings.
- Set SSCG Enable = 1 (enable spreading, reload spreading state machines)
- Lock Registers (Page 0, Register 0, Bit 0 = 1)

Table 2. SSCG and Clock Multiplication Register Settings

PAGE	REGISTER		DEFAULT	BITS	NAME	DESCRIPTION
2	24	18	1111 1000	[7:5] [4:3] [2:0]	PLL Control 1	Master PLL Range Setting for PLL1 and PLL2 when Autorange is off. Set to 111. PLL1 Charge Pump Current Control Default = 11 PLL1 Filter Bandwidth Control Default = 000
2	25	19	0001 1000	[7:5] [4:3] [2:0]	PLL Control 2	Reserved Default = 000 PLL2 Charge Pump Current Control Default = 11 Set to 00 when using SSCG. PLL2 Filter Bandwidth Control Default = 000 Set to 111 when using SSCG.

Table 2. SSCG and Clock Multiplication Register Settings (continued)

PAGE	REGISTER	DEFAULT	BITS	NAME	DESCRIPTION
2	26	1A	0000 0000		
			[7:6]	SSCG Control 1	Spread Rate Multiplier (Increases modulation frequency in low pixel frequency applications) 00 1x - Default 01 2x 10 4x 11 Reserved
			[5]		SSCG Spread Boost 0 Normal, PLL divide step is 1/28 1 Boost, PLL divide step is 1/56. Narrower and cleaner spread for 1ch and 2ch modes, but limits max pixel freq to 25 MHz.
			[4]		SSCG Spread Gain 0 Spread widths as specified in [3:2] 1 Spread widths are 2x [3:2] settings
			[3:2]		SSCG Spread Width (Fmod = Fcenter +/- Width/2) 00 5% 01 2.5% 10 1.25% 11 0.625%
			[1]		SSCG SH Sync Enable 0 Spread unsynched, once SSCG Enable and Register Lock Control are set, SSCG wil begin immediately. 1 Spread synched to SH interval, once SSCG Enable is set, the SSCG will begin at the first SH Interval.
			[0]		SSCG Enable 0 Spread off 1 Spread on

Table 2. SSCG and Clock Multiplication Register Settings (continued)

PAGE	REGISTER	DEFAULT	BITS	NAME	DESCRIPTION
2	27	1B	0000 0010		<p>[7]</p> <p>Load SSCG state machine (SSCG Enable 0->1 also performs this function) 0 Normal 1 Load state machine (self clearing)</p> <p>[6]</p> <p>FIFO Reset at SH_R 0 FIFO is only reset when SSCG started 1 FIFO is reset at SH_R. Only useful in Slave Mode with Spread LVDS Only set. Ensures that FIFO counters are centered if SH_R period is consistently shorter or longer than Line Length settings.</p> <p>[5]</p> <p>Spread Waveform Reset at SH_R 0 Spread waveform not reset by SH_R 1 Spread waveform reset by SH_R</p> <p>[4]</p> <p>Override PLL2 Lock Detector 0 PLL2 Lock Detector Normal SSCG Control 2 1 Force PLL2 Lock Detect = 1. Set to 1 when using SSCG.</p> <p>[3]</p> <p>Override PLL1 Lock Detector 0 PLL1 Lock Detector Normal 1 Force PLL1 Lock Detect = 1. Useful only if using a large multiplication factor and a lot of jitter is present in the source clock.</p> <p>[2]</p> <p>Spread MaxRate 0 Spread Normal 1 Force Spreading to highest modulation frequency instead of tied to Line Length Setting.</p> <p>[1:0]</p> <p>PLL Mode Select 11 Spread All System Clocks, No Multiplication 10 PLLs and SSCG Disabled - Default 01 Spread All System Clocks, Multiplication Enabled 00 Spread Output Clocks Only, Multiplication Enabled</p>
2	28	1C	0000 0000	Clock Mult M	<p>Multiplying PLL. $F_{out} = F_{in} \times M/N$ $M = mmmmmmm + 1$ (1 to 256)</p>
2	29	1D	0000 0000	Clock Mult N	<p>Multiplying PLL. $F_{out} = F_{in} \times M/N$ $N = nnnnnnn + 1$ (1 to 256)</p>
2	30	1E	0000 0000		<p>[7]</p> <p>FIFO Reset 0 FIFO normal operating 1 Force reset of FIFO (self clearing)</p> <p>[6:0]</p> <p>SSCG Control 3 FIFO and Spread Waveform SH_R Reset Holdoff Delay reset of FIFO and Spread Waveform from 0 to 127 ADC clock cycles after the internal synchronized SH_R. To allow this event to occur during SH Interval after all valid pixels in the pipeline have been processed.</p>

7.4 Device Functional Modes

7.4.1 Mode 3 - Three Channel Input/Synchronous Pixel Sampling

In Mode 3, the OS_R , OS_G , and OS_B input channels are sampled synchronously. The sampled input signals are then processed in parallel through their respective channels with each channel offset and gain adjusted by their respective control registers. The signals are then routed through a 3-1 MUX to the ADC. The order in which pixels are processed through the MUX to the ADC is programmable (OS_R - OS_G - OS_B , or OS_B - OS_G - OS_R) and is synchronized by the SH pulse.

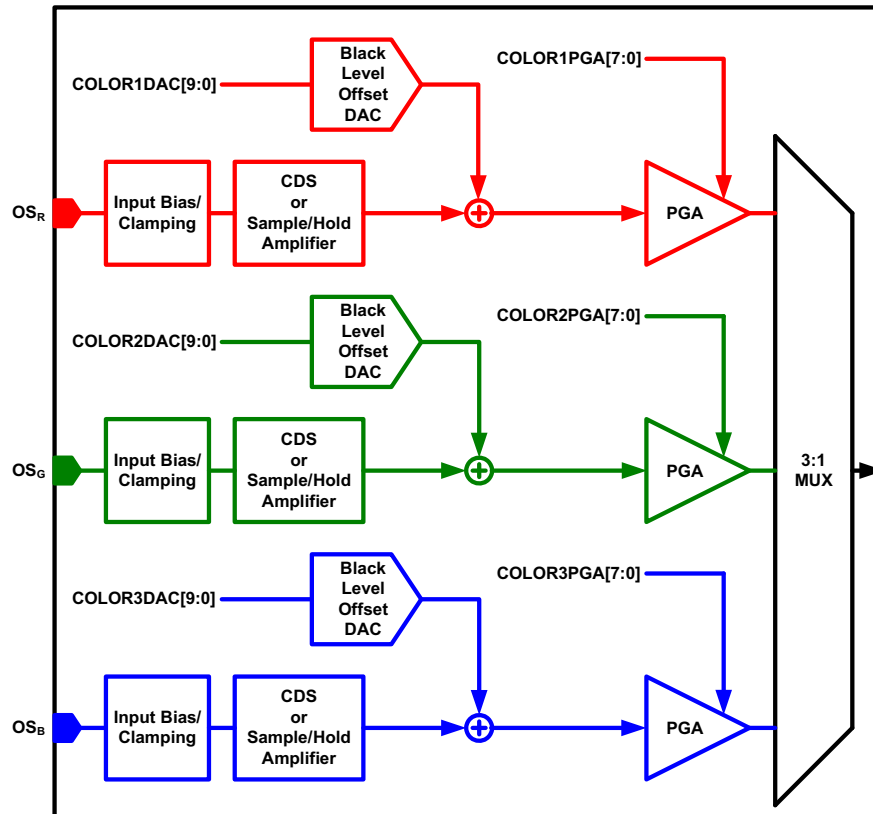

Figure 6. Synchronous Three Channel Pixel Mode Signal Routing

Table 3. Mode 3 Operating Details

			DETAIL
Channels Active	OS_B & OS_G & OS_R		3 channel synchronous pixel sampling
Channel Sample Rate	27		MSPS per Channel (max)
ADC Sample Rate		81	MSPS (max)
$f_{ADC}: f_{INCLK}$	Internal 3x Clock Selected	3:1	$f_{INCLK} = 27$ MHz (max)
	Internal 1x Clock Selected	1:1	$f_{INCLK} = 81$ MHz (max)
Output Sequencing	SH Signal --> R-G-B-R-G-B-R-G-B-> or SH Signal --> B-G-R-B-G-R-B-G-R->		

7.4.2 Mode 2 - Two Channel Input/Synchronous Pixel Sampling

Mode 2 is useful for CCD sensors with a Black and White line with Even and Odd pixels. In its default configuration, Mode 2 samples Even sensor pixels via the Blue Channel Input, and Odd sensor pixels via the Green Channel Input. The selection of Even/Odd inputs can be changed through the serial interface registers. Sampling of the Even and Odd inputs is performed synchronously.

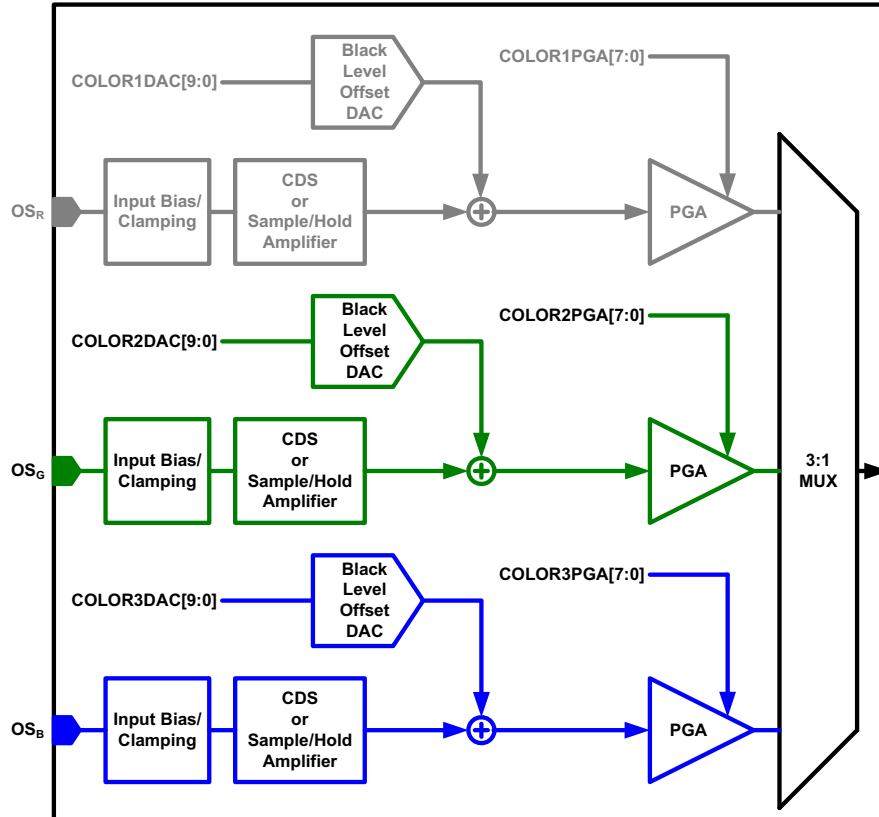

Figure 7. Mode 2 Signal Routing

Table 4. Mode 2 Operating Details

		DETAIL	
Channels Active	OS _G and OS _B (Default) or OS _R and OS _G or OS _B and OS _R		Two inputs synchronously processed as Even and Odd Pixels. Channel inputs are configurable.
Channel Sample Rate	30		MSPS per Channel (max)
ADC Sample Rate		60	MSPS (max)
f _{ADC} : f _{INCLK}	Internal 2x Clock Selected	2:1	f _{INCLK} = 30 MHz (max)
	Internal 1x Clock Selected	1:1	f _{INCLK} = 60 MHz (max)
Output Sequencing	SH Signal --> Even-Odd-Even-Odd-Even-Odd-Even--> or SH Signal --> Odd-Even-Odd-Even-Odd-Even-Odd-->		

7.4.3 Mode 1 - One Channel Input

In Mode 1a, all pixels are processed through a single input (OS_R , OS_G , or OS_B) chosen through the control register setup. This mode is useful in applications where only one input channel is used. The selected input is programmable through the control register. In this mode, the maximum channel speed is 30MSPS per channel with the ADC running at 30MSPS.

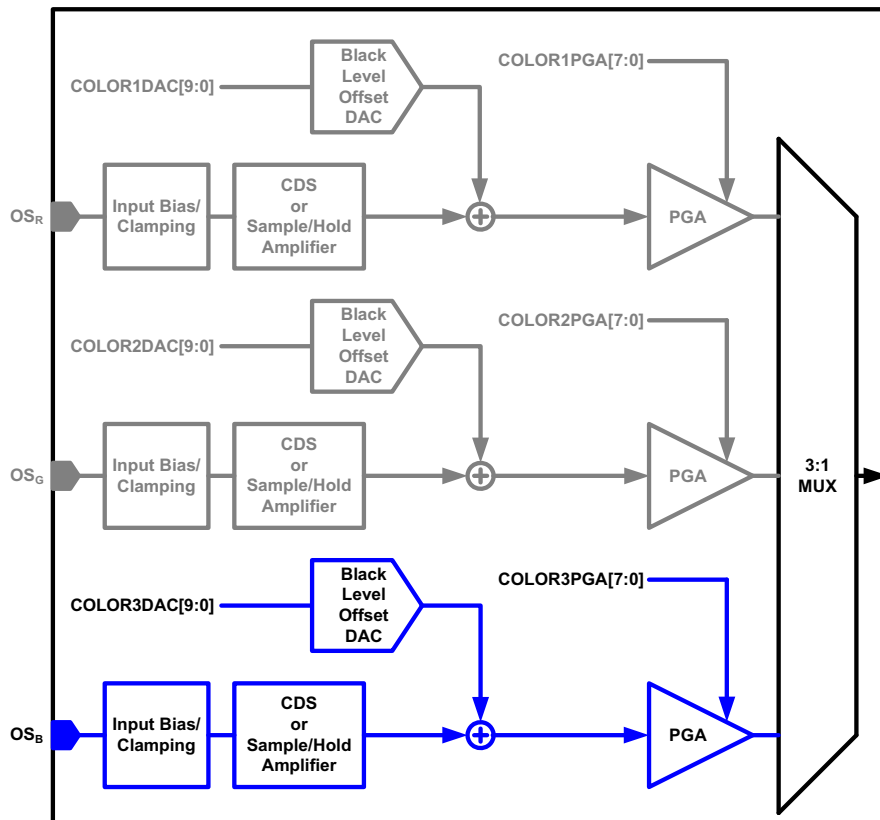

Figure 8. Mode 1a Signal Routing

Table 5. Mode 1 Operating Details

			DETAIL
Channels Active	OS_R or OS_G or OS_B		One color active for all lines.
Channel Sample Rate	30		MSPS per Channel (max)
ADC Sample Rate		30	MSPS (max)
$f_{ADC}: f_{INCLK}$	Internal 1x Clock Selected	1:1	$f_{INCLK} = 25\text{MHz}$ (max)
Output Sequencing	SH Signal → Color 1 → Color 1 → Color 1 → Color 1 → Color 1 →		

Table 6. Modes of Operation Register Settings Table

OPERATING MODE	SAMPLING INPUT(S)	SIGNAL PATH(S)	OUTPUT SEQUENCING MODE 3 AND 2 = PIXEL SEQ
Mode3-RGB Forward	OS _R OS _G OS _B	RGB	Pixel _R → Pixel _G → Pixel _B →
Mode3-RGB Reverse	OS _R OS _G OS _B	RGB	Pixel _B → Pixel _G → Pixel _R →
Mode2-RG Forw.	OS _R OS _G	RG	Pixel _R → Pixel _G →
Mode2-RG Rev.	OS _R OS _G	RG	Pixel _G → Pixel _R →
Mode2-GB Forw.	OS _G OS _B	GB	Pixel _G → Pixel _B →
Mode2-GB Rev.	OS _G OS _B	GB	Pixel _B → Pixel _G →
Mode2-RB Forw.	OS _R OS _B	RB	Pixel _R → Pixel _B →
Mode2-RB Rev.	OS _R OS _B	RB	Pixel _B → Pixel _R →
Mode1-R Mono	OS _R	R	Color Line Seq: R → R → R → R →
Mode1-G Mono	OS _G	G	Color Line Seq: G → G → G → G →
Mode1-B Mono	OS _B	B	Color Line Seq: B → B → B → B →
CISa	Mode 1 or 2 or 3	Any	2, 3, or 4 lines in sequence
			Gain and Offset are channel specific. LM98714 style CB bits indicate channel used to process data. Additional CB bits can be used to identify current line in sequence.
CISb	Mode 1 or 2 or 3	Any	2 or 3 lines in sequence
			Gain and Offset for all channels are common, and change from line to line based on current color in sequence. LM98714 style CB bits indicate channel used to process data. Additional CB bits can be used to identify current line in sequence.

7.4.4 Input Bias and Clamping

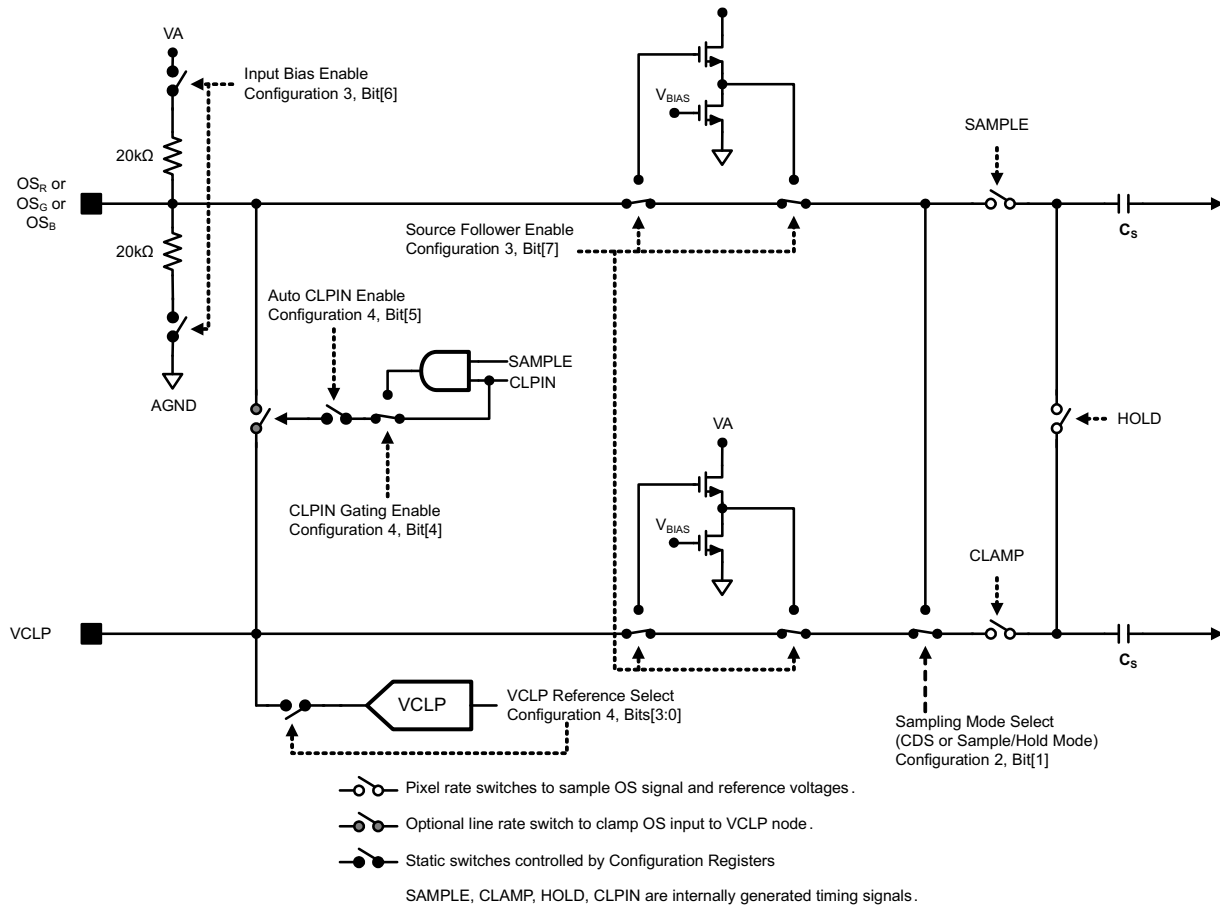

Figure 9. Input Bias and Clamping Diagram

7.4.4.1 Input Bias and Clamping - AC Coupled Applications

The inputs to the LM98725 are typically AC coupled through a film capacitor and can be sampled in either Sample and Hold Mode (S/ H Mode) or Correlated Double Sampling Mode (CDS Mode). In either mode, the DC bias point for the LM98725 side of the AC coupling capacitor is set using the circuit of Figure 8 which can be configured to operate in a variety of different modes. A typical CCD waveform is shown in Figure 9. Also shown in Figure 9 is an internal signal “SAMPLE” which can be used to “gate” the CLPIN signal so that it only occurs during the “signal” portion of the CCD pixel waveform.

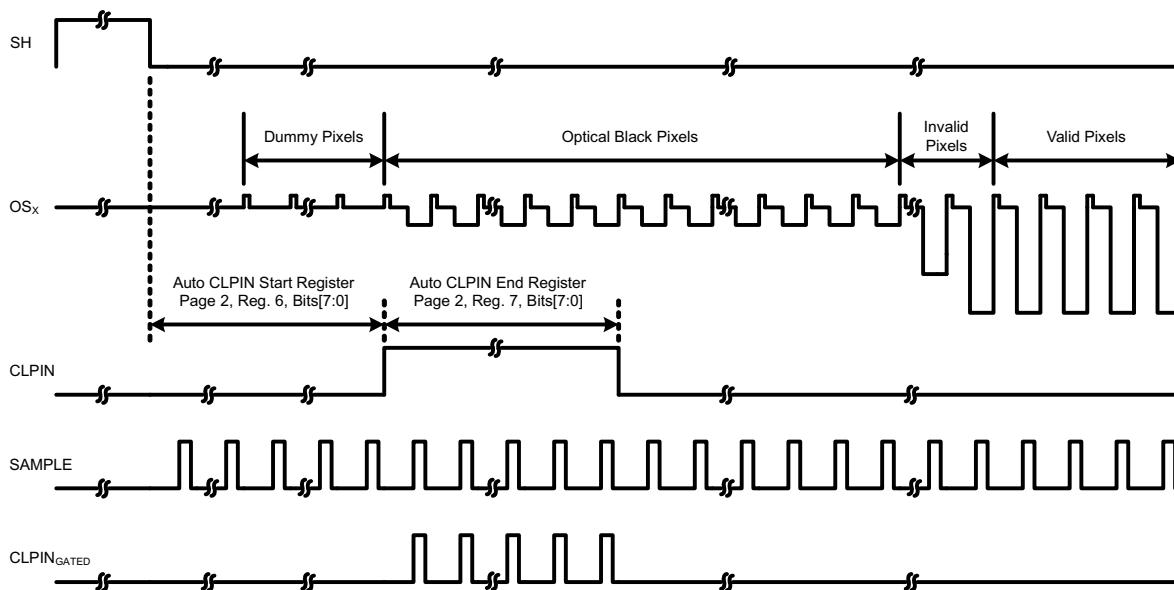

Figure 10. Typical CCD Waveform and LM98725 Input Clamp Signal (CLPIN)

7.4.5 Sample/Hold Mode

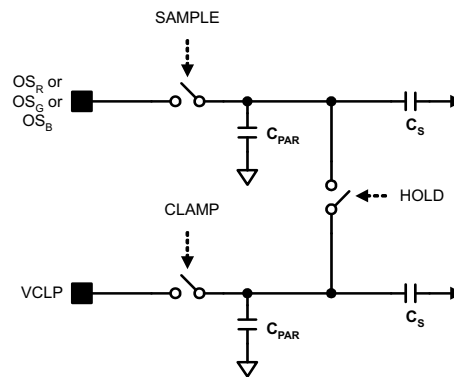

Figure 11. Sample and Hold Mode Simplified Input Diagram

Proper DC biasing of the CCD waveform in Sample and Hold mode is critical for realizing optimal operating conditions. In Sample/ Hold mode, the Signal Level of the CCD waveform is compared to the DC voltage on the VCLP pin. In order to fully utilize the range of the input circuitry, it is desirable to cause the Black Level signal voltage to be as close to the VCLP voltage as possible, resulting in a near zero scale output for Black Level pixels.

In Sample/Hold Mode, the DC bias point of the input pin is typically set by actuating the input clamp switch (see [Figure 9](#)) during optical black pixels which connects the input pins to the VCLP pin DC voltage. The signal controlling this switch is an auto-generated pulse, CLPIN. CLPIN is generated with a programmable pixel delay with respect to the SH Interval and a programmable # of pixels Duration. These parameters are available through the serial interface control registers.

Actuating the input clamp will force the average value of the CCD waveform to be centered around the VCLP DC voltage. During Optical Black Pixels, the CCD output has roughly three components. The first component of the pixel is a “Reset Noise” peak followed by the Reset (or Pedestal) Level voltage, then finally the Black Level voltage signal. Taking the average of these signal components will result in a final “clamped” DC bias point that is close to the Black Level signal voltage.

To provide a more precise DC bias point (that is, a voltage closer to the Black Level voltage), the CLPIN pulse can be “gated” by the internally generated SAMPLE clock. This resulting CLPIN_{GATED} signal is the logical “AND” of the SAMPLE and CLPIN signals as shown in [Figure 10](#). By using the CLPIN_{GATED} signal, the higher Reset Noise peak will not be included in the clamping period and only the average of the Reset Level and Black Level components of the CCD waveform will be centered around VCLP.

7.4.6 DC Coupled Applications

In some applications, particularly with CIS sensors, the output voltage is within a voltage range that will allow DC coupling of the signal. When using Sample/Hold mode, DC coupling eliminates any problems with signal droop across the line caused by voltage changes across the coupling capacitor. When DC coupling, the Auto CLPIN should be disabled.

There are two ways of setting the proper DC levels in this type of application. If the sensor has a Vref output pin, this can be connected to the VCLP pin of the LM98725. The internal VCLP generation should be disabled to allow this external reference to set the Black Level for the chip close to the black pixel level of the sensor.

Many CIS sensors will not have a Vref output. In these applications, the internal VCLP voltage of the LM98725 can be set to the level that is closest to the black pixel level of the sensor.

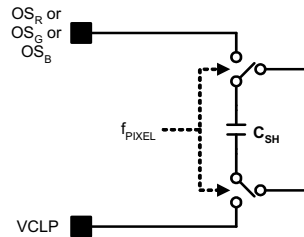

Figure 12. Equivalent Input Switched Capacitance S/H Mode

In Sample and Hold Mode, the impedance of the analog input pins is dominated by the switched capacitance of the CDS/Sample and Hold amplifier. The amplifier switched capacitance, shown as C_S in Figure 11, and internal parasitic capacitances can be estimated by a single capacitor switched between the analog input and the VCLP reference pin for Sample and Hold mode. During each pixel cycle, the modeled capacitor, C_{SH} , is charged to the OS_X -VCLP voltage then discharged. The average input current at the OS_X pin can be calculated knowing the input signal amplitude and the frequency of the pixel. If the application requires AC coupling of the CCD output to the LM98725 analog inputs, the Sample and Hold Mode input bias current may degrade the DC bias point of the coupling capacitor. To overcome this, Input Source Follower Buffers are available to isolate the larger Sample and Hold Mode input bias currents from the analog input pin (as discussed in the following section). As shown in CDS Mode, the input bias current is much lower for CDS mode, eliminating the need for the source follower buffers.

7.4.7 Input Source Follower Buffers

The OS_R , OS_G , OS_B inputs each have an optional Source Follower Buffer which can be selected with Main Configuration Register 3 at Page 0, Register 3, Bit[7]. These source followers provide a much higher impedance seen at the inputs. In some configurations, such as Sample and Hold Mode with AC coupled inputs, the DC bias point of the input nodes must remain as constant as possible over the entire length of the line to ensure a uniform comparison to reference level (VCLP in this case). The Source Followers effectively isolate the AC input coupling capacitor from the switched capacitor network internal to the LM98725's Sample and Hold/ CDS Amplifier. This results in a greatly reduced charge loss or gain on the AC Input coupling capacitor over the length of a line, thereby preserving its DC bias point.

The Source Followers should only be used in the 1.2V input range (that is, Gain Mode Register at Page 1, Register 0, Bit[0] = 1, CDS Gain = 2x). Using the Source Followers in the 2.4V (that is, Gain Mode Register at Page 1, Register 0, Bit[0] = 0, CDS Gain = 1x). input range will result in a loss of performance (mainly linearity performance at the high and low ends of the input range).

7.4.8 CDS Mode

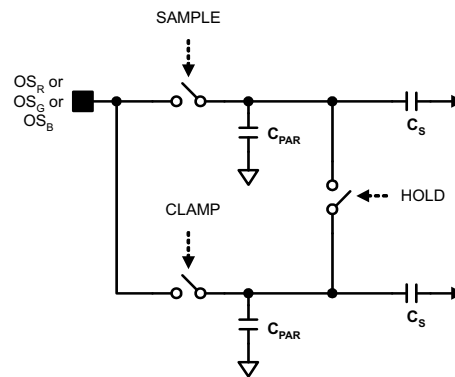

Figure 13. CDS Mode Simplified Input Diagram

Correlated Double Sampling mode does not require as precise a DC bias point as does Sample and Hold mode. This is due mainly to the nature of CDS itself, that is, the Video Signal voltage is referenced to the Reset Level voltage instead of the static DC VCLP voltage. The common mode voltage of these two points on the CCD waveform have little bearing on the resulting differential result. However, the DC bias point does need to be established to ensure the CCD waveform's common mode voltage is within rated operating ranges.

The CDS mode biasing can be performed in the same way as described in the [Sample/Hold Mode](#), or, an alternative method is available which precludes the need for a CLPIN pulse. Internal resistor dividers can be switched in across the OS_R, OS_G, and/or OS_B inputs to provide the DC bias voltage.

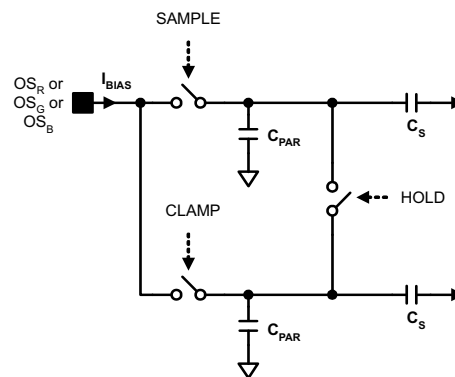

Figure 14. CDS Mode Input Bias Current

Unlike in Sample and Hold Mode, the input bias current in CDS Mode is relatively small. Due to the architecture of CDS switching, the average charge loss or gain on the input node is ideally zero over the duration of a pixel. This results in a much lower input bias current, whose main source is parasitic impedances and leakage currents.

As a result of the lower input bias current in CDS Mode, maintaining the DC Bias point the input node over the length of a line will require a much smaller AC input coupling capacitor.

7.4.9 VCLP DAC

The VCLP pin provides the reference level for incoming signals in Sample and Hold Mode. The pin's voltage can be set by writing to the VCLP Configuration Register on register page 0. By default, the VCLP pin voltage is established by an internal resistor divider which sets the voltage to $0.85 V_A$.

The VCLP buffer can also be disconnected and the pin driven externally by the another voltage in the application, such as V_{ref} from some CIS sensors.

Table 7. VCLP Voltage Setting

VCLP CONFIGURATION PAGE 0, REGISTER 0x04, BITS[2:0]	TYPICAL VCLP OUTPUT (FINAL SILICON TARGETS)
000	$0.85V_A$ (Default)
001	$0.9 V_A$
010	$0.95 V_A$
011	$0.6 V_A$
100	$0.55 V_A$
101	$0.4 V_A$
110	$0.35 V_A$
111	$0.15 V_A$

7.4.10 Gain and Offset Correction

Each input channel has individual settings for offset (DAC) and gain (PGA and CDS/SH gain).

7.4.10.1 Analog Offset

Analog offset (DAC) settings are individually adjustable for each color. In addition, there are (optionally) separate settings for Even and Odd pixels being processed through each color channel. This feature is designed to support specific CCD sensors that have two CCD transfer arrays per color, which may introduce different offset for the Even versus Odd pixels.

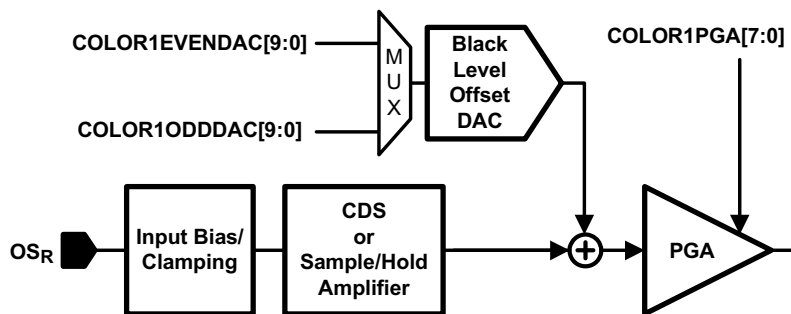

Figure 15. Analog Offset Applied Prior to POA

The Black Level Offset DACs are set with a 9 bit plus sign value. This gives an approximate adjustment range of ± 300 mV or ± 600 mV when the CDS/SH Gain is set to 1x or 2x.

The analog offset registers are found at Page 1, Registers 0x04h to 0x0Fh.

7.4.10.2 Digital Offset

In addition, digital offset can be added to color data at the output of the ADC in the Digital Offset block. The digital offsets are a ± 6 bit value. This value is summed with the upper 11 bits of the ADC output. Therefore, the effective offset range is from +2016 to -2048 lsb of the ADC output.

The digital offset registers are found at Page 1, Registers 0x10h to 0x15h.

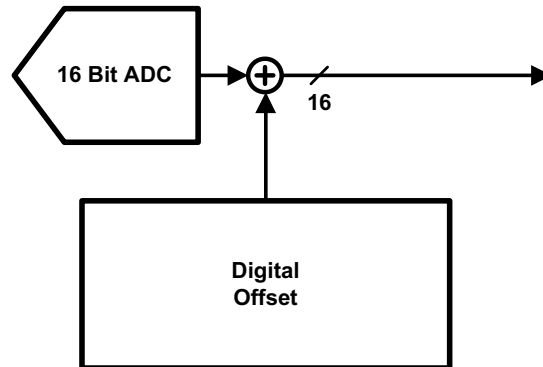

Figure 16. Digital Offset Applied to ADC Output

7.4.10.3 Even/Odd Offset Coefficients

Certain CCD sensors may have different offset voltages for the Even versus the Odd pixels. To optimize the image processing of these pixels, separate coefficients can be stored, and applied for the Even and Odd pixels. The Even/Odd offset feature is enabled by setting Page 0, Register 0x02h, Bit 0 = 1. Bimodal correction, discussed below, is automatically disabled when Even/Odd offset coefficients are enabled.

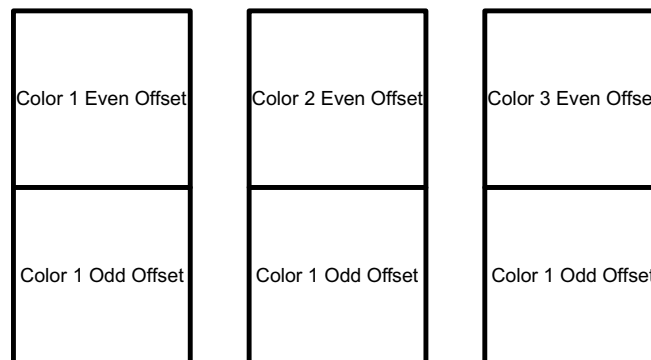

Figure 17. Digital Offset - Details of Color and Even/Odd Coefficients

- **Analog Gain**
 - The gain of each input channel can be adjusted at two points in the signal chain.
- **CDS/SH Gain - Page 1, Register 0x00h**
 - A 1x or 2x gain setting is available in the CDS/SH amplifier.
 - By default, one common CDS/SH gain setting is used for all input channels. If desired, individual CDS/SH gain settings can be used for each input. To enable this feature, set Page 1, Register 0x00h, Bit 2 = 1.
- **PGA Gain - Page 1, Registers 0x01h, 0x02h, 0x03h**
 - An 8 bit PGA (Programmable Gain Amplifier) is also available. The PGA gain curve is non-linear for optimal performance in imaging applications, and is shown on the following plot. The approximate gain equation is: Gain (V/V) = $180 / (277 - \text{PGA_Code})$, Gain (dB) = $20 \log_{10}(180 / (277 - \text{PGA_Code}))$.

The gain setting registers are found at Page 1, Registers 0x00h, 0x01h, 0x02h and 0x03h.

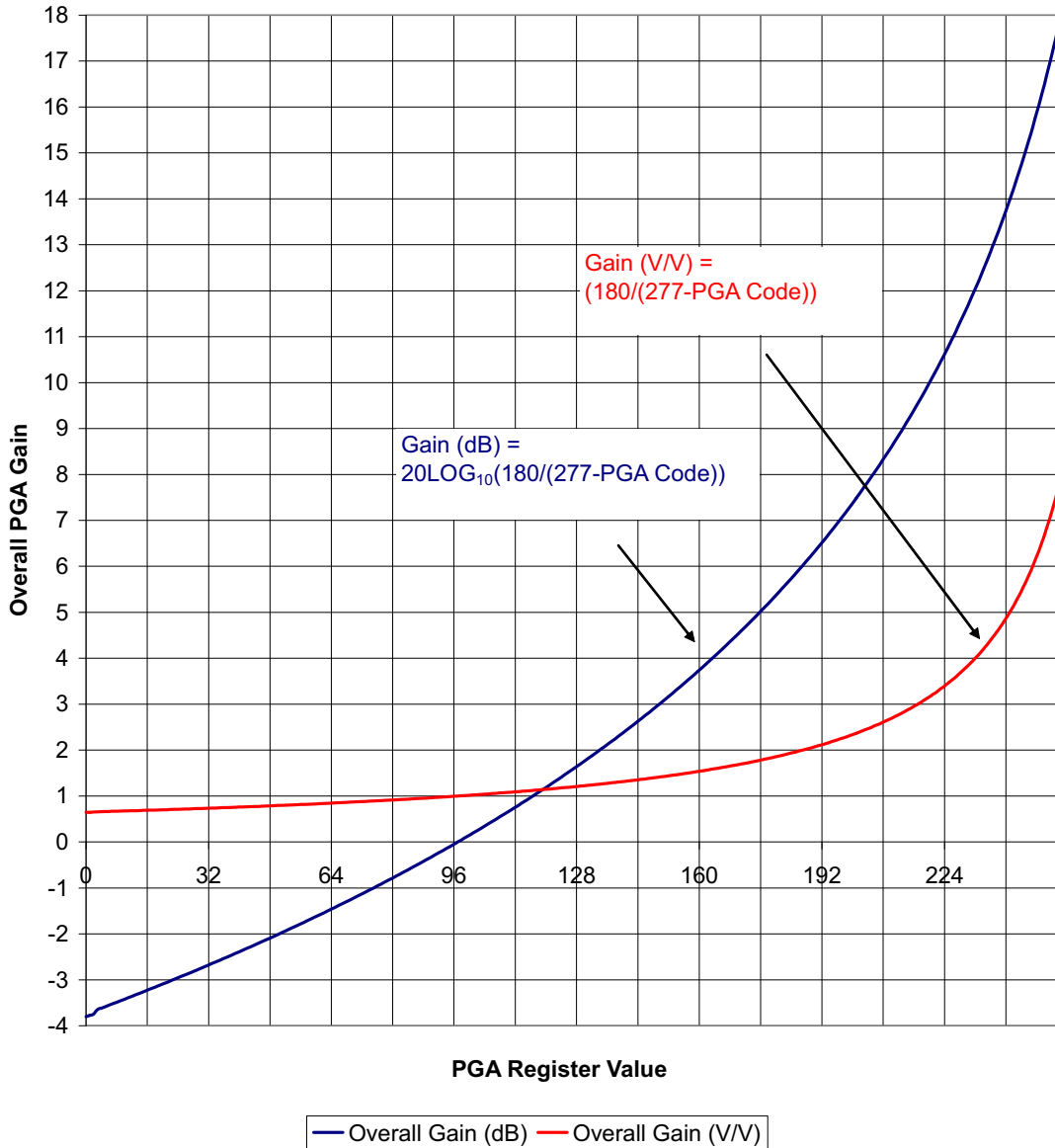

Figure 18. PGA Gain vs. PGA Gain Code

- **Dual Gain Mode - Page 1, Register 0x00h, Bit 1, and Registers 0x16h, 0x17h, 0x18h**
 - In many scanning systems, the system illumination and optics characteristics will result in a much higher optical efficiency in the pixels near the middle of the sensor, compared with the pixels at the beginning and end of the sensor. If a single gain setting is used for all pixels, the middle pixels will be near clipping, while the ones at the edges can be at 1/2 scale or lower. This results in lower signal to noise for the edge pixels. To combat this problem, the LM98725 incorporates an optional Dual Gain system. When enabled, the system provides a second set of PGA gain registers to set the “high” gain for each input channel. The “normal” gain settings will be applied during the “active/white” pixels, while the “high” gain settings will be applied for all pixels before and after the “active/white” pixels (see [LM98725 Typical Line Timing and Pixel Gain Regions](#)).
 - The Dual Gain enable bit is found at Page 1, Register 0x00h, Bit 1. The High Gain PGA settings are found at Page 1, Registers 0x16h to 0x18h.

7.4.11 LM98725 Typical Line Timing and Pixel Gain Regions

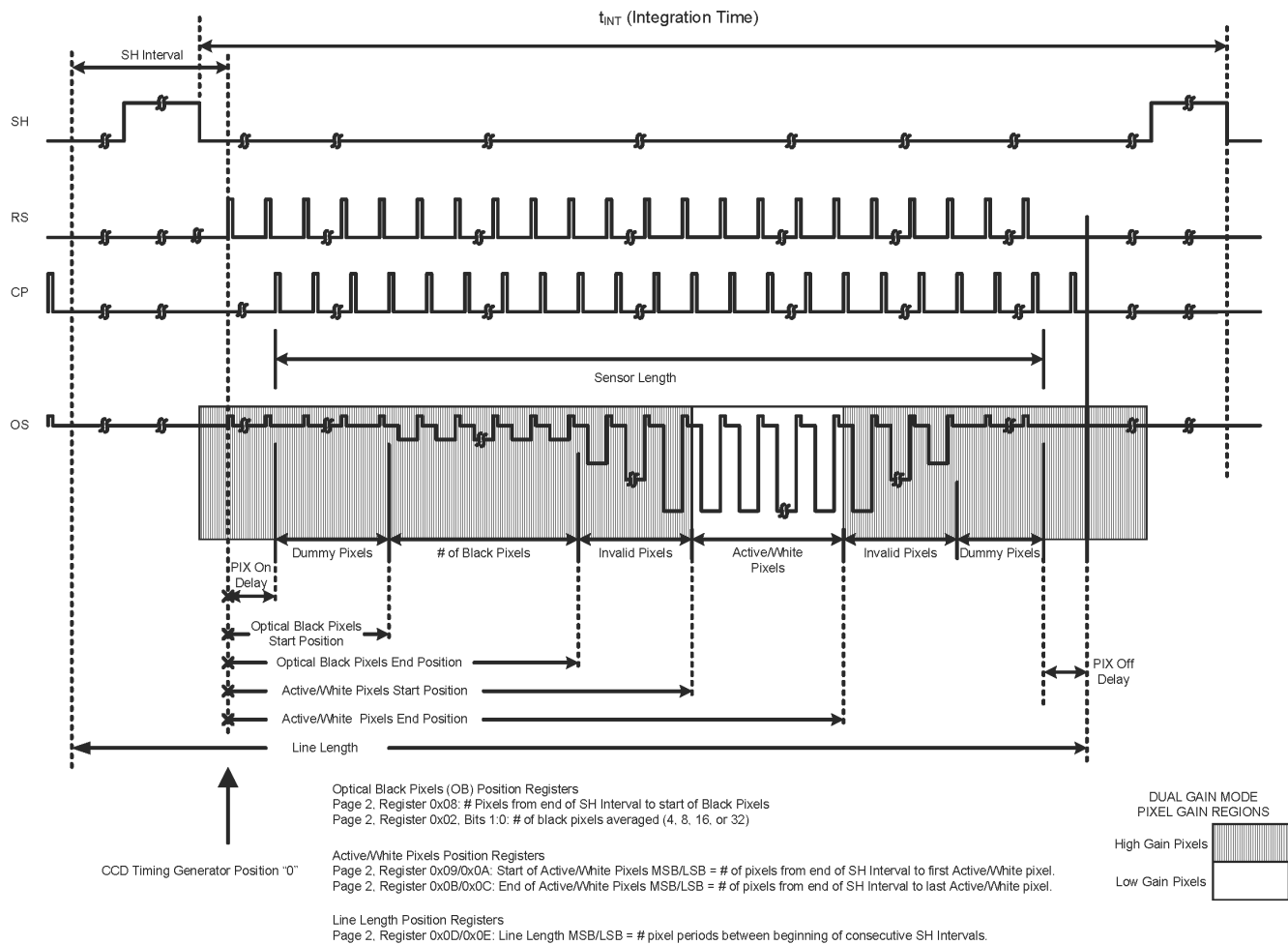

Figure 19. Typical Line Timing and Pixel Gain Regions

7.4.12 Automatic Black and White Level Calibration Loops

7.4.12.1 Calibration Overview

The offset and gain settings in the AFE will normally be set to optimize the range of the sensor output signal within the ADC input range. These settings can be calculated in a host ASIC and loaded into the AFE during the calibration procedure. To reduce the processing required to do these calculations, the LM98725 has built in feedback or calibration loops that will automatically adjust the offset and gain settings. A number of register values must be initially set to optimize the calibration for the particular application.

7.4.12.2 Different Modes for Different Needs

The calibration features of the LM98725 are not intended to be used during active scanning, but rather before scanning begins, or in the page gap between images. Generally, more time is available to perform the initial calibration before scanning begins. Page gap calibration must be necessarily short to ensure the process finishes in the limited number of scan lines available.

The Black and White Fine Tuning, and Black Calibration Only modes can be used during the page gap to adjust for small differences in offset/gain that occur over time.

Black and White Full Calibration should be run before the initial scanning process, or periodically between major jobs to take care of larger shifts in offset/gain of the input signal.

7.4.12.3 Calibration Initiation

Once these settings have been made, the Register Lock Control bit (Page 0, Register 0, Bit 0) should be set to begin converting pixels. Once the sensor data from the test image is stable the calibration process can be started by either setting the CAL register bit at Page 0, Register 0x01h, Bit 5, or by applying a logic high to the CAL input pin. (Both of these inputs are active when the Register Lock Control is set.) The CAL input pin is particularly useful for implementing page gap calibration.

7.4.12.4 Key Calibration Settings

Table 8. Key Calibration Settings

● General Settings	
● Calibration Mode	Page 2, Register 0, Bits[1:0]
Black Calibration Only	00
Black and White Full Calibration	01
Black and White Fine Tuning	10
● Number of Lines	Page 2, Register 1
● Black Loop Specific Settings	
● # Black Pixels Averaged	Page 2, Register 2, Bits[1:0]
● Black Target	Page 2, Register 3
● Black Pixels Start	Page 2, Register 8
● ADAC Scaling	Page 2, Register 2, Bits[3:2]
● DDAC Scaling	Page 2, Register 2, Bits[5:4]
● DDAC enable/disable	Page 2, Register 0, Bit 2
● White Loop Specific Settings	
● White Target	Page 2, Register 5
● White Loop Tolerance	Page 2, Register 4, Bits[6:3]
● White Pixel Averaging Window Size	Page 2, Register 4, Bits[2:0]
● Active/White Pixels Start	Page 2, Register 0x09h, 0x0Ah
● Active/White Pixels End	Page 2, Registers 0x0Bh, 0x0Ch

The calibration loops are intended to be used prior to scanning the page or between pages being scanned. The black loop calibrates the channel offset such that the ADC outputs the desired code for Optical Black Pixels. The white loop calibrates the channel gain such that the ADC outputs the desired maximum white value when scanning a white target image.

The Black Loop and White loop will both update until the # Lines setting is met. Settings of 1 to 254 lines will cause the loops to run for that many lines, and then stop. A setting of 255 will cause the calibration loops to run indefinitely.

While using the Auto Black Level Correction Loop, the DAC registers are re-written as required every line the loop is running.

While using the Auto White Level Correction Loop, the PGA registers are re-written as required every line the loop is running.

7.4.12.5 General Black Loop Operation

During calibration, the following general process is performed:

- Beginning at Black Pixels Start, the selected number of black pixels are averaged.
- This Black Average value is compared with the Black Target to give the Black Error value.
- In general, if the Black Average > Black Target, the new DAC values will be lower than the previous ones. If the Black Average < Black Target the new DAC values will be higher than the previous ones.
- The ADAC Scaling and DDAC Scaling values are used to balance the speed of convergence against the tolerance for noise in the data. The smallest (1/8) scaling values will give slower convergence, but will make the system respond more slowly to noisy data. The highest (1/2) will result in the fastest convergence, but will respond more quickly to noisy data. The DDAC scaling factor of Linear - 1LSB adjust will result in a maximum change of one lsb of the DDAC value, regardless of how great the difference between Black Average and Black Target
- The number of Black Pixels to be processed by the algorithm is set at Page 2, Register 2, Bits[1:0]. 4, 8, 16 or 32 pixels can be averaged together to determine the current Black Value. Averaging the highest number of pixels possible for the sensor in use will improve the accuracy and repeatability of the Black Average value.

The delay from the end of the SH Interval to the first Black Pixel to be processed is set at Page 2, Register 8. A delay of up to 255 pixels can be set.

7.4.12.6 ADAC/DDAC Convergence

At the beginning of the calibration process, the ADAC will be used to reduce the Black Error as much as possible. Once further adjustments of the ADAC can no longer reduce the Black Error, the ADAC adjustments will stop and the DDAC will be used. *If users would rather apply digital offset corrections in their ASIC, the DDAC corrections can be omitted by setting the DDAC disable bit at Page 2, Register 0x00h, Bit 2.

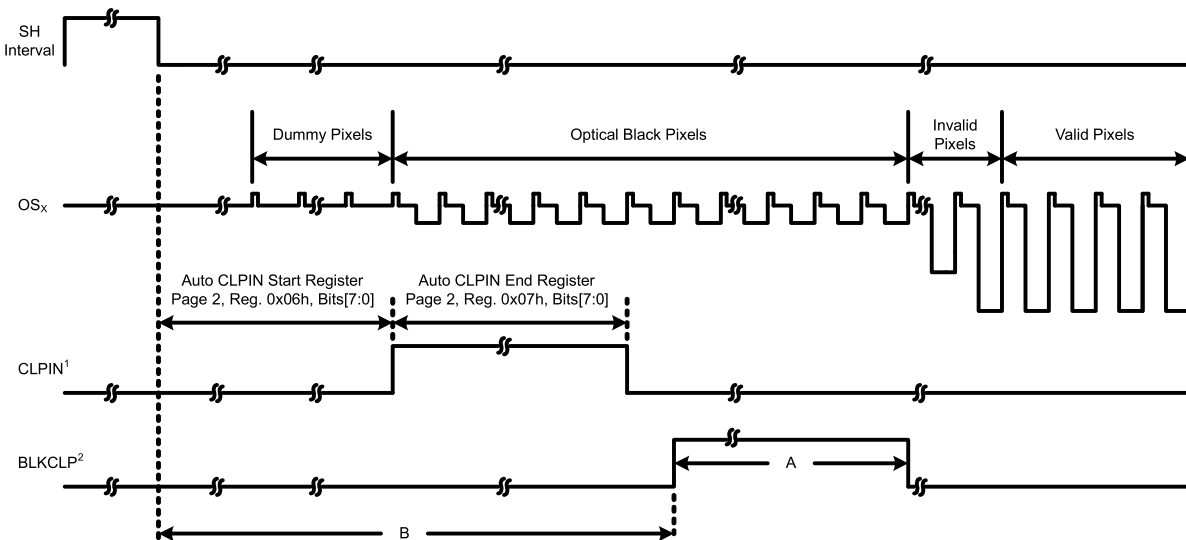

1. CLPIN represents the internally generated input clamping signal. The Black level Calibration Loop should be triggered after CLPIN returns low during Optical Black Pixels.
2. BLKCLP represents the time during a line where the Black level Calibration Loop is active. BLKCLP is programmed to begin relative to the end of the SH Interval.

A = Number of Optical Black Pixels the Black Level Calibration Loop averages per line. It is configured by the Black Cal Config. Register (Page 2, Reg. 2, Bits[1:0])
 B = Black Level Clamp Position with delay from SH. Black Loop Start Register (Page 2, Reg. 0x08h)

Figure 20. Black Loop Timing

7.4.12.7 General White Loop Operation

The White Peak value is determined by a moving window average done throughout the Active/White pixels region of the line (Refer to [LM98725 Typical Line Timing and Pixel Gain Regions](#)). The size of the moving window is set at Page 2, Register 4, Bits[2:0]. 4, 8, 16 or 32 (default) pixels are averaged together at a time and compared with the previous Peak White value. If the new White Average is greater than the previous Peak White value, then the Peak White value is set equal to the White Average. The window is then shifted over to the next group of pixels (one window width) and a new average is calculated. This process is repeated until the Active/White Pixels End value is reached. The final Peak White value is then compared with the White Target value (Page 2, Register 5). The gain settings are then adjusted to make the Peak White value closer to the White Target value.

7.4.12.8 White Loop Modes

- **White Full Calibration (Cold start or Pre-Job)** - In this mode, the gain settings are completely reset to default at the beginning of the loop. The first change or gain decision is whether the CDS/SH gain setting will be 1x or 2x. Subsequent decisions are made to adjust the PGA setting to provide the Peak White value that is closest to the White Target value.
- **White Fine Tuning (Page Gap Calibration)** - In this mode, the previous gain settings are used as the starting point. The CDS/SH gain setting will not be changed. The PGA gain will be increased or decreased by one step at a time, to fine tune the gain. This mode is normally used where only minor changes in the white level are expected.

7.4.12.9 Bimodal (Automatic) Correction

Due to the architecture of the ADC used in the LM98725, it is possible that a small offset in the resulting data will be present between the Even and Odd pixels processed by the device. This offset is referred to as a Bimodal distribution in the data. It can occur because the signals being processed go through two different paths to achieve the required throughput. Each of these paths can give a slightly different signal offset, resulting in the bimodal distribution in output data, for a given fixed input voltage.

When the automatic Black Level (offset) correction circuit is engaged, a portion of that circuitry automatically corrects the bimodal distribution. The bimodal correction applied is stored at Page 1, Registers 0x1Ch, 0x1Dh, and 0x1Eh. The stored value is divided by two. Half is added to the Even pixels, and half is subtracted from the Odd pixels.

7.4.13 Coarse Pixel Phase Alignment

Precise placement of the CCD video signal sampling point is a critical aspect in any typical imaging application. Many factors such as logic gate propagation delays and signal skew increase the difficulty in properly aligning the CCD pixel output signals with the AFE input sampling points. The LM98725 provides two powerful features to aid the system level designer in properly sampling the CCD video signal under a large range of conditions. The first feature, discussed in this section, is the Coarse Pixel Phase Alignment block. As the name implies, this block provides a very coarse range of timing adjustment to align the phase of the CCD Pixel output with the phase of the LM98725 sample circuit. The second feature, discussed in [Internal Sample Timing](#), is the block which is designed for fine tuning of the sampling points within the selected Coarse Pixel Alignment Phase. A small portion of a typical imaging application is shown in [Figure 21](#).

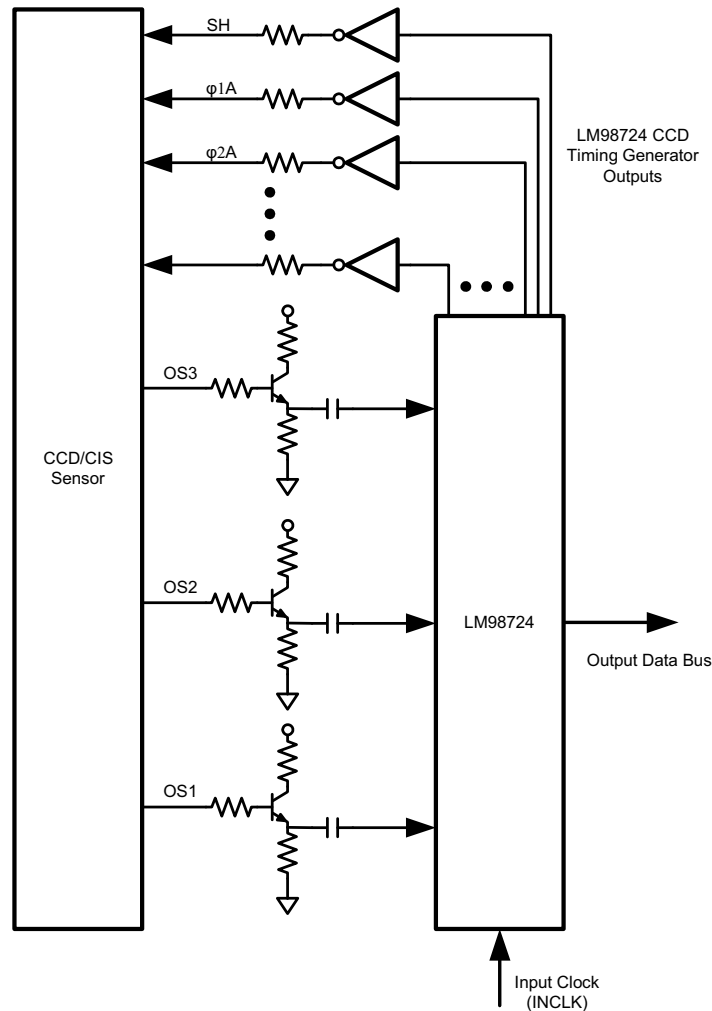
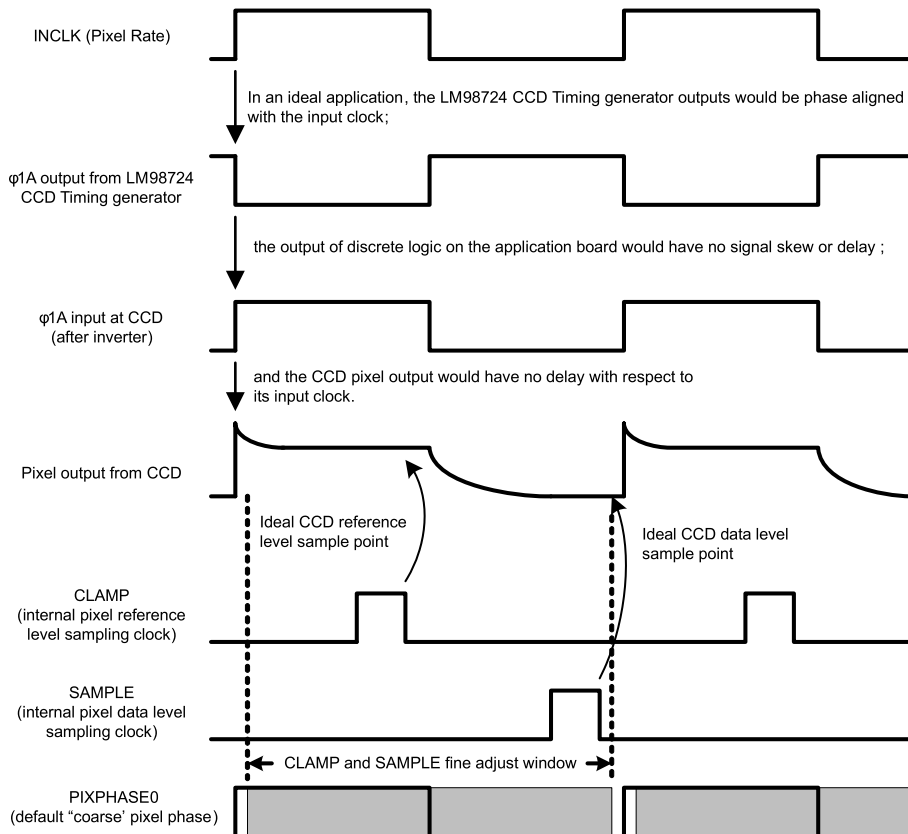

Figure 21. Typical AFE/CCD Interface

As shown in [Figure 21](#), the LM98725 provides the timing signals to drive the CCD using external logic gates to drive the high capacitance CCD clock pins. The pixels are shifted out of the CCD, through the emitter follower buffers and received by the LM98725 inputs for processing.

In an ideal application, depicted in Figure 22, the Pixel output signal would be in phase with the timing signals that drove the CCD. The LM98725 input sampling clocks (CLAMP and SAMPLE) are adjustable within a pixel period. By default, the pixel period (or pixel “phase”) is defined to be in line with the input clock. As shown in the ideal case in Figure 22, CLAMP and SAMPLE can be properly adjusted to their ideal positions within the pixel phase, shown below at the stable region near the end of the pedestal and data phases.



By default, the LM98724's internal sampling clocks (CLAMP and SAMPLE) are adjustable within PIXPHASE0, an internal pixel rate clock which is in phase with the input clock.

Figure 22. Clock Alignment in an Ideal Application

However, in a real system, propagation delays exist in all stages of the signal chain. These propagation delays will lead to a shift in the CCD Pixel outputs with respect to the LM98725 input clock. The phase shift of the CCD Pixel output, demonstrated in [Figure 23](#), can lead to significant sample timing issues if not properly corrected.

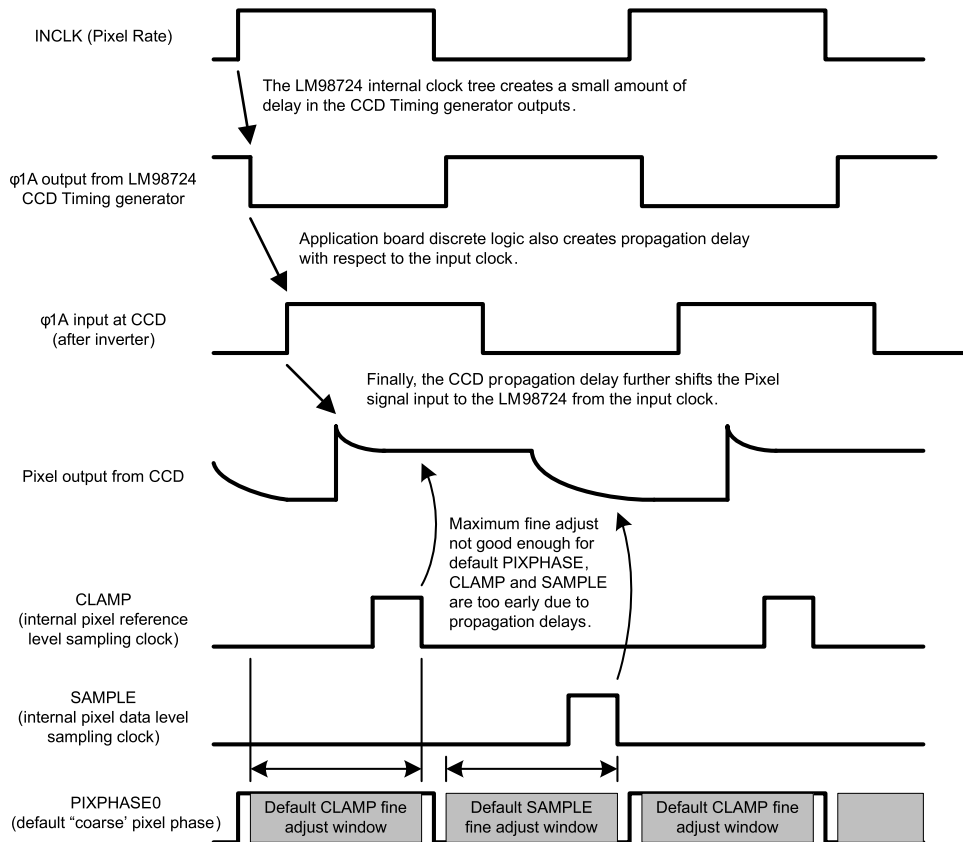
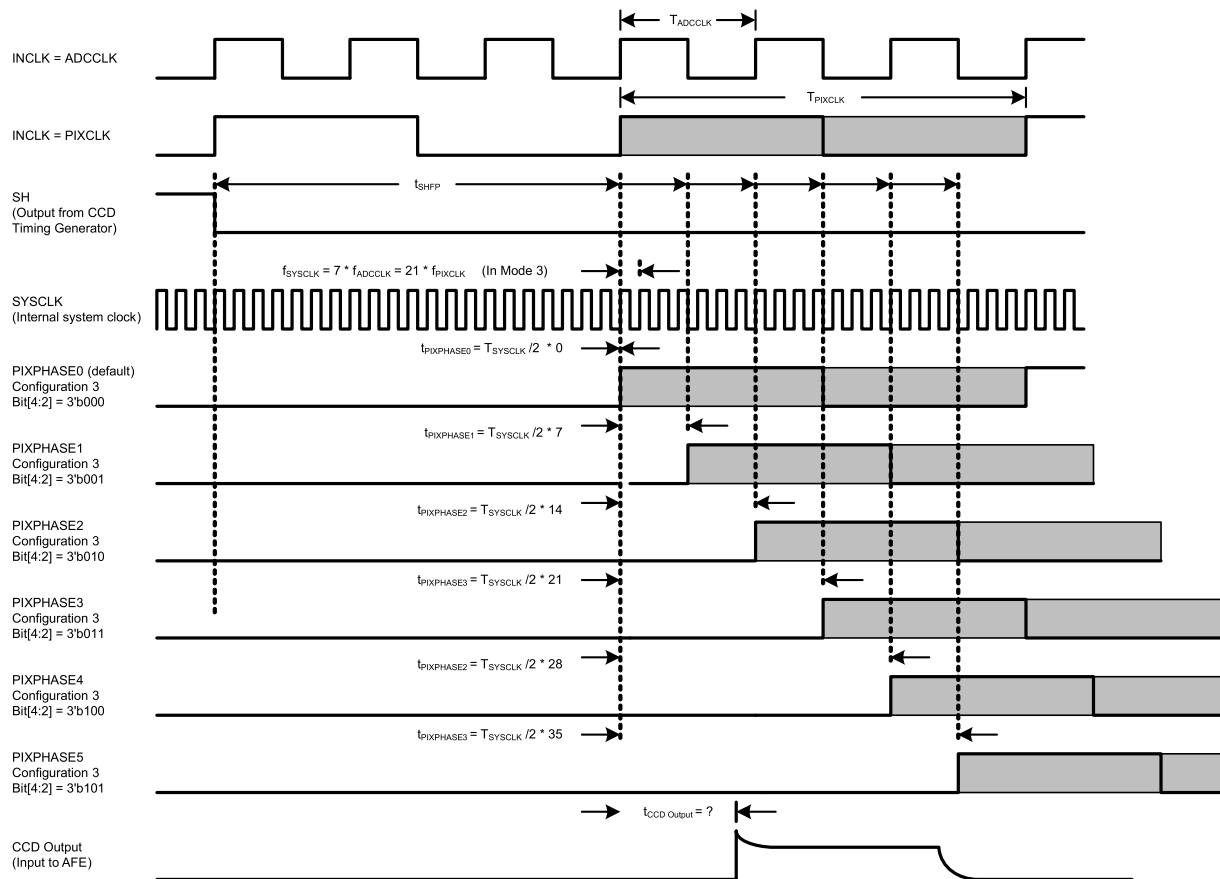

Figure 23. CCD Output Phase Shift in a Real Application

In the default mode, the LM98725 sampling is performed during a clock period whose phase is aligned with the input clock (ignoring any clock tree skew for the moment). The actual sampling clocks are adjustable within the clock period, as shown in [Figure 23](#) (shown for CDS mode in the diagram) and further described in the [Internal Sample Timing](#) section. As shown in the diagram, the delay of the CCD Pixel output is shifted far enough that the fine CLAMP and SAMPLE clocks cannot be placed in a stable portion of the waveform. To remedy this situation, the LM98725's Coarse Pixel Phase Alignment feature allows the designer to shift the entire phase of the analog front end with respect to the input clock. This allows the designer to choose one of four sampling phases which best matches the delay in the external circuitry. Once the "Coarse Pixel Phase" has been chosen, the designer can then fine tune the sampling clocks using the fine adjustment (see [Internal Sample Timing](#).)

The four available Coarse Pixel Phases (PIXPHASE0 - PIXPHASE3) are depicted in [Figure 24](#) (Mode 3), [Figure 25](#) (Mode 2) and [Figure 26](#) (Mode 1). Also shown in the diagrams are the external input clock (INCLK) and a typical CCD output delayed from the input clock.



The CCD output will usually have a measurable delay with respect to the input clock to the AFE. The AFE's internal sampling clocks are based on one of six PIXPHASE clocks. These PIXPHASE settings provide coarse adjustment of the internal AFE clock domain to best match the phase of the incoming CCD signal. Fine adjustment of the sampling clocks is discussed in another section. In this example above, PIXPHASE2 appears to provide the closest match for the incoming CCD signal.

Figure 24. Mode 3 Coarse Pixel Adjustment

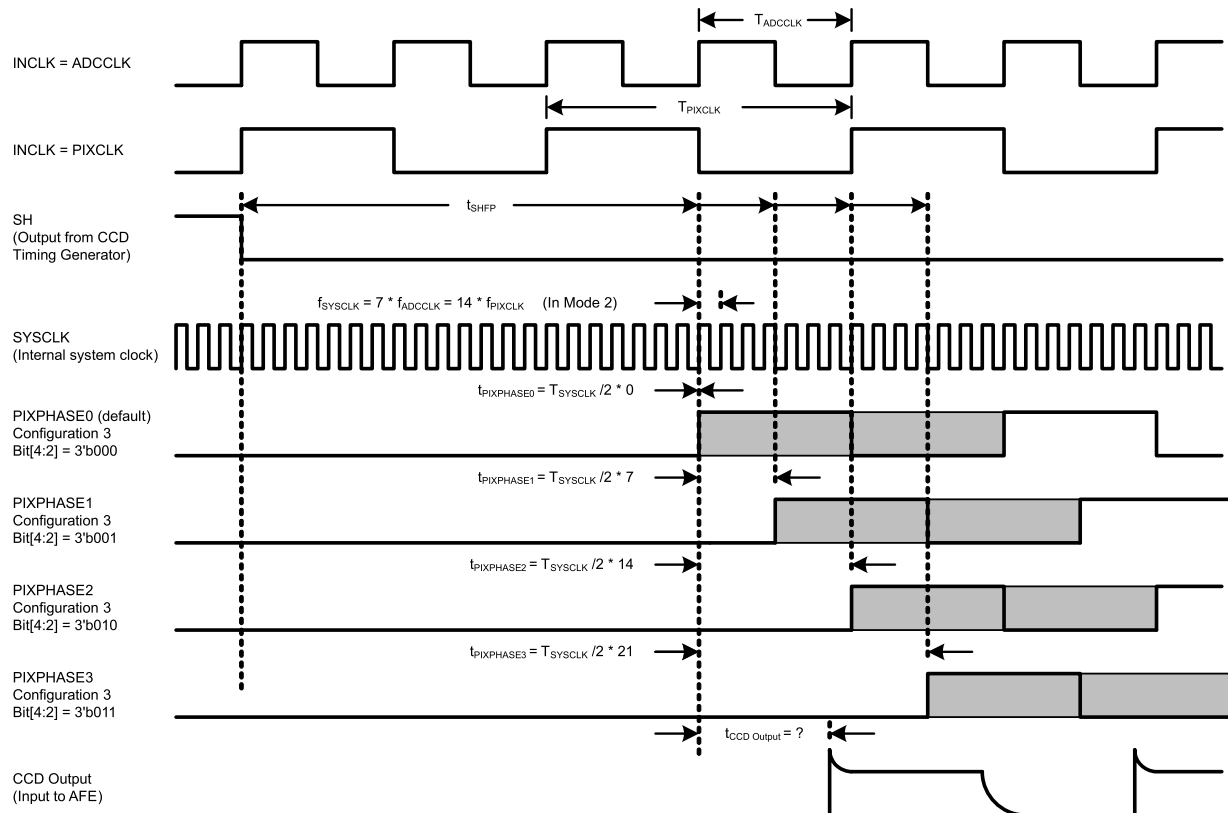

The CCD output will usually have a measurable delay with respect to the input clock to the AFE. The AFE's internal sampling clocks are based on one of four PIXPHASE clocks. These PIXPHASE settings provide coarse adjustment of the internal AFE clock domain to best match the phase of the incoming CCD signal. Fine adjustment of the sampling clocks is discussed in another section. In this example above, PIXPHASE2 appears to provide the closest match for the incoming CCD signal.

Figure 25. Mode 2 Coarse Pixel Phase Adjustment

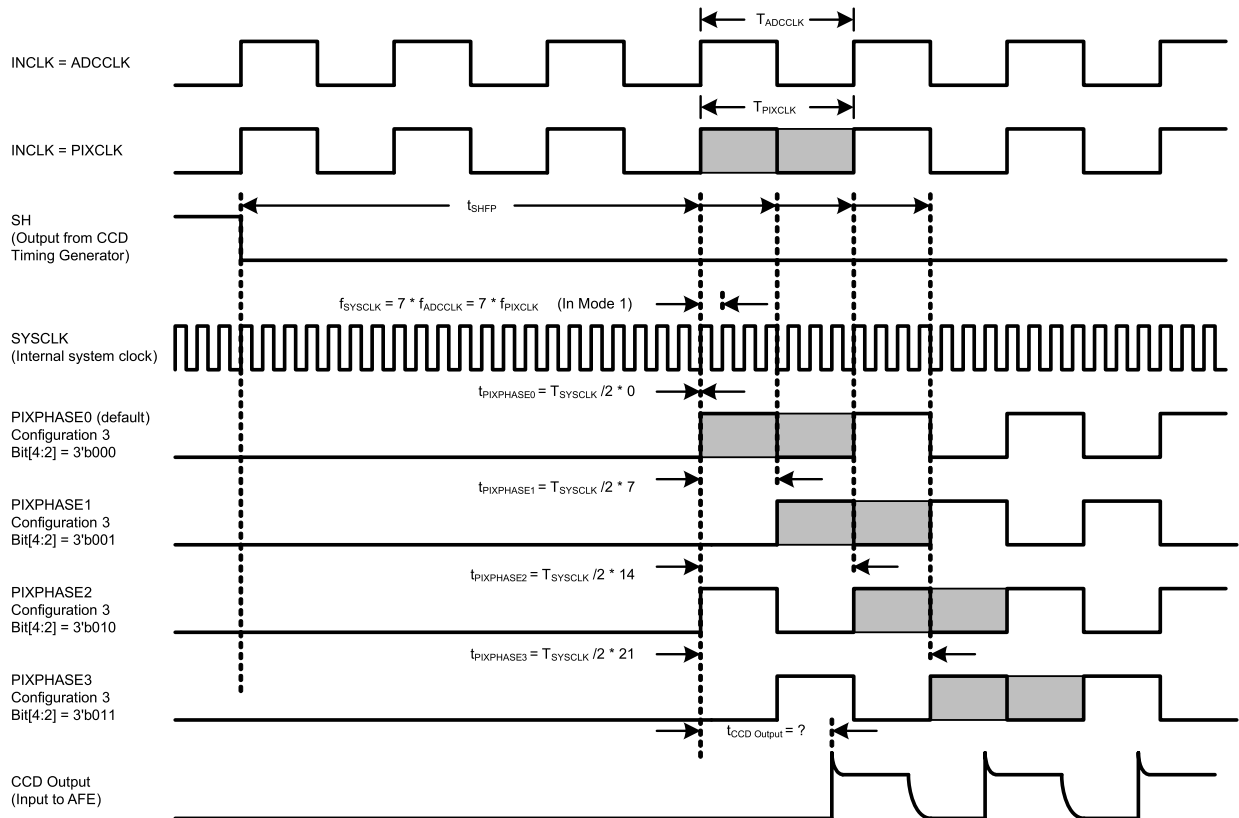

The CCD output will usually have a measurable delay with respect to the input clock to the AFE. The AFE's internal sampling clocks are based on one of four PIXPHASE clocks. These PIXPHASE settings provide coarse adjustment of the internal AFE clock domain to best match the phase of the incoming CCD signal. Fine adjustment of the sampling clocks is discussed in another section. In this example above, PIXPHASE2 appears to provide the closest match for the incoming CCD signal.

Figure 26. Mode 1 Coarse Pixel Phase Adjustment

7.4.14 Internal Sample Timing

A typical CCD input signal is depicted in [Figure 27](#) and [Figure 28](#). Also shown are the internally generated SAMPLE and CLAMP pulses. These signals provide the sampling points of the input signal (OSX). The timing of SAMPLE and CLAMP is derived from an internal system clock (SYSCLK).

The pixel's reference level input (depicted as V_{REF}) is captured by the falling edge of the CLAMP pulse. In Sample/Hold Mode the V_{REF} input is a sample of the VCLP DC voltage. In CDS Mode the CLAMP pulse samples the pedestal Level of the CCD output waveform.

The pixel's signal level input (depicted as V_{SIG}) is captured by the SAMPLE pulse. In either Sample/Hold or CDS Mode, the V_{SIG} input is the signal level of the CCD output waveform.

The LM98725 provides fine adjustment of the CLAMP and SAMPLE pulse placement within the pixel period. This allows the user to program the optimum location of the CLAMP and SAMPLE falling edges. The available fine tuning locations for CLAMP and SAMPLE are shown in [Figure 29](#) and [Figure 30](#) for each sampling mode (CDS or S/H) and channel mode (3, 2, or 1 Channel).

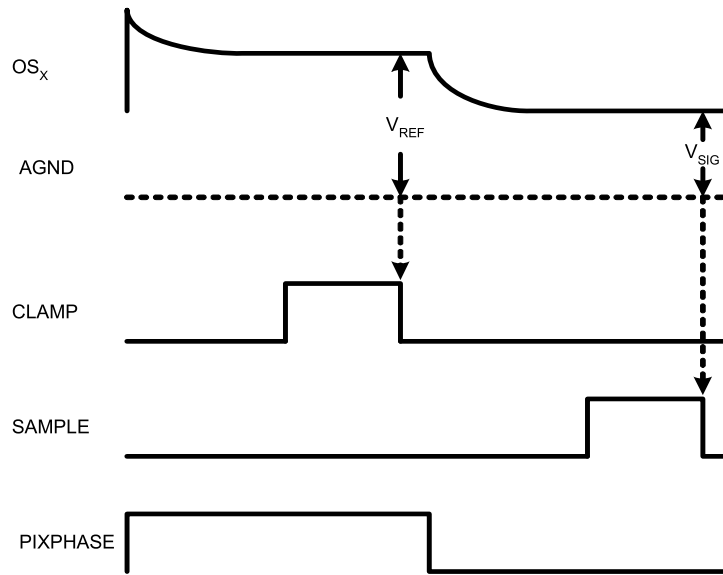

CLAMP and SAMPLE are the internal sampling clocks for the input CDS amplifier. CLAMP and SAMPLE are adjustable within the selected PIXPHASE setting.

In CDS mode, CLAMP falling edge captures the pixel reference level (V_{REF}).
 In CDS mode, SAMPLE falling edge captures the pixel signal level (V_{SIG}).

PIXPHASE is 1 of 4 internal reference clocks used to estimate the phase of the incoming pixel. Once the coarse estimation of the pixel location is chosen via PIXPHASE, the CLAMP and SAMPLE clocks can be fine tuned within PIXPHASE to their optimum location.

Figure 27. Pixel Sampling in CDS Mode

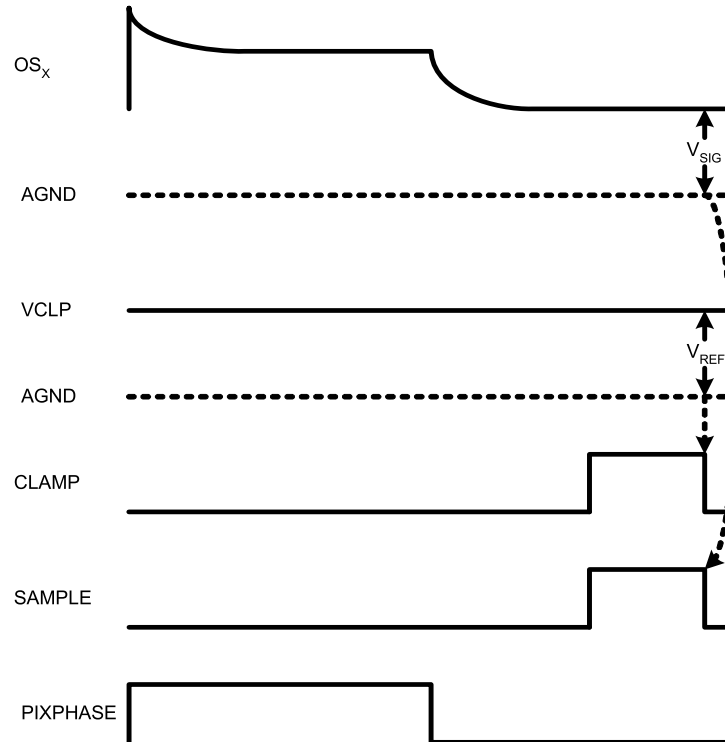

CLAMP and SAMPLE are the internal sampling clocks for the input CDS amplifier. CLAMP and SAMPLE are adjustable within the selected PIXPHASE setting.

In S/H mode, CLAMP falling edge captures the VCLP pin voltage as the pixel reference voltage (V_{REF}).
 In S/H mode, SAMPLE falling edge captures the pixel signal level (V_{SIG}).

PIXPHASE is 1 of 4 internal reference clocks used to estimate the phase of the incoming pixel. Once the coarse estimation of the pixel location is chosen via PIXPHASE, the CLAMP and SAMPLE clocks can be fine tuned within PIXPHASE to their optimum location.

Figure 28. Pixel Sampling in S/H Mode

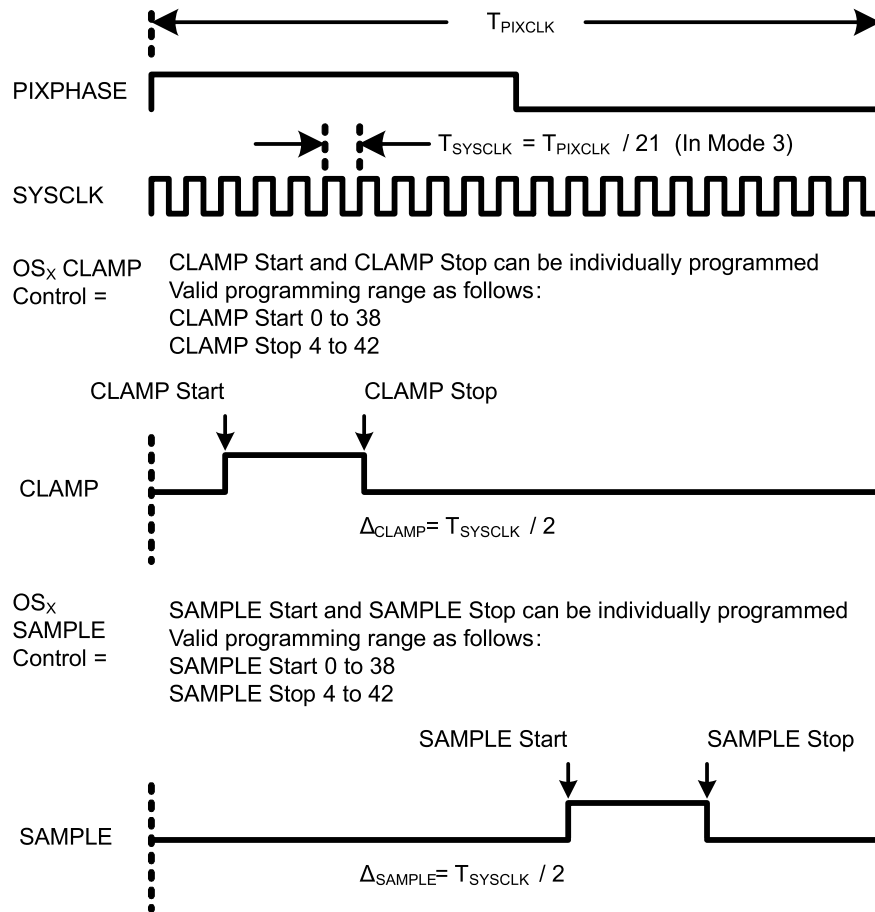
Figure 29. 3 Channel (Mode 3) CLAMP and SAMPLE Timing

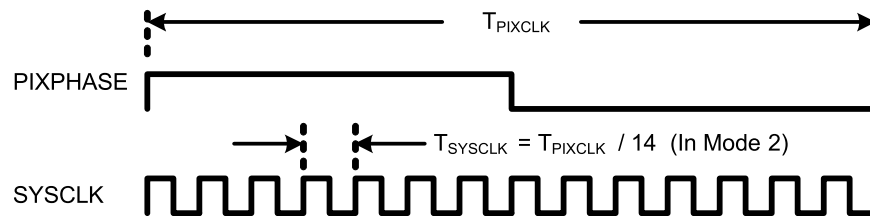

OS_x CLAMP Control = CLAMP Start and CLAMP Stop can be individually programmed
Valid programming range as follows:
CLAMP Start 0 to 24
CLAMP Stop 4 to 28

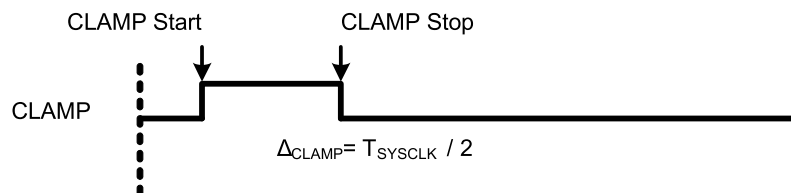

OS_x SAMPLE Control = SAMPLE Start and SAMPLE Stop can be individually programmed
Valid programming range as follows:
SAMPLE Start 0 to 24
SAMPLE Stop 4 to 28

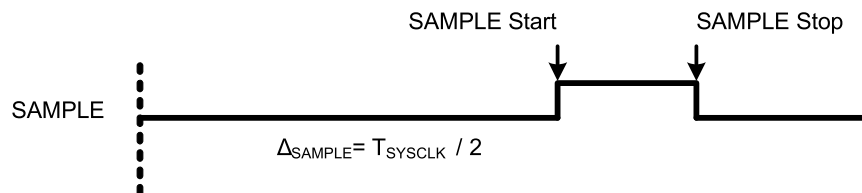

Figure 30. 1 or 2 Channel (Mode 1, Mode 2) CLAMP and SAMPLE Timing

7.4.14.1 CCD Timing Generation

A flexible internal timing generator is included to provide clocking signals to CCD and CIS sensors. A block diagram of the CCD Timing Generator is shown in Figure 32.

Figure 31. CCD Timing Generation

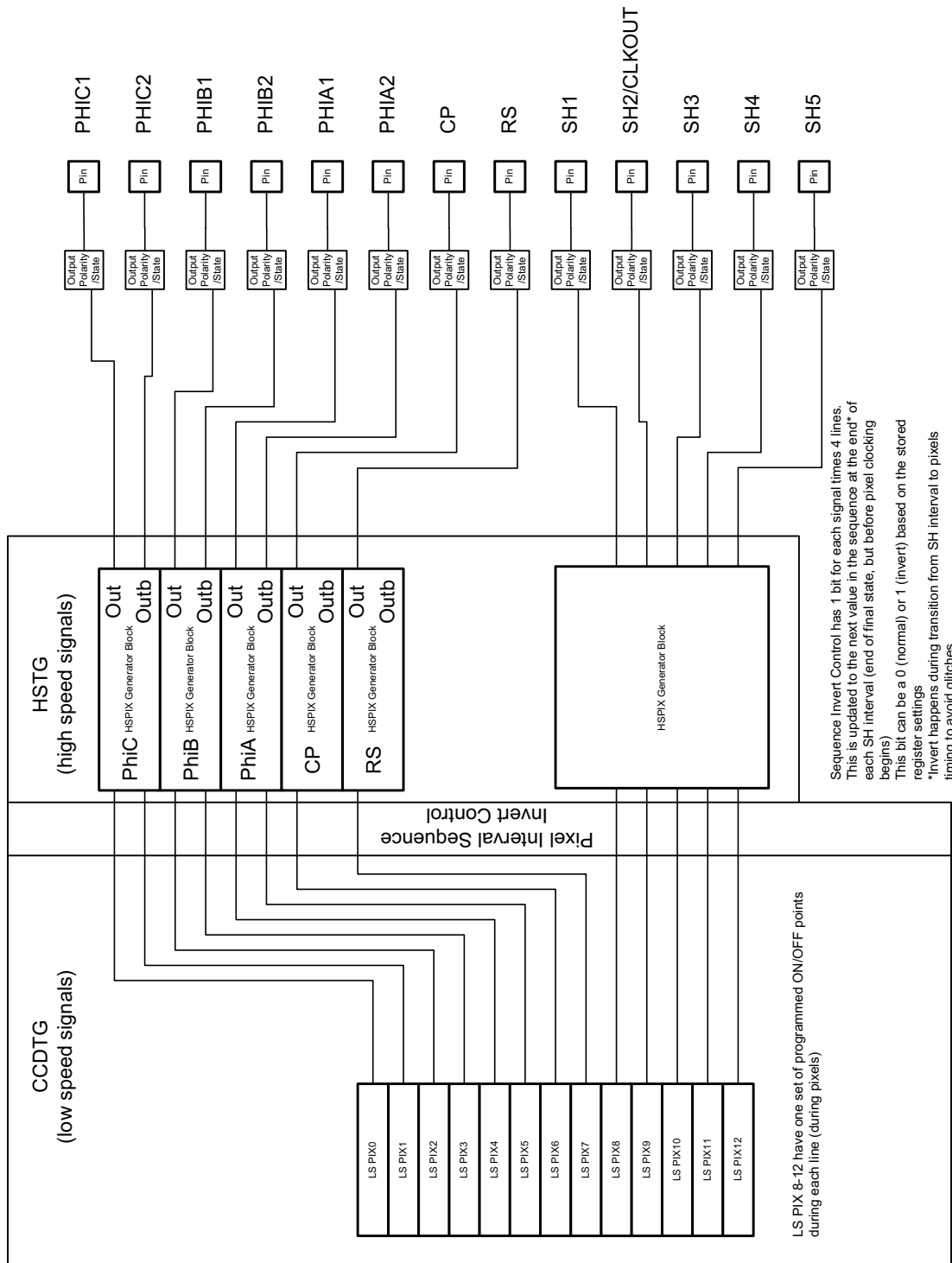

Figure 32. CCD Timing Generator Block Diagram

Examples of the various operating modes and settings are shown in [Figure 33](#) through [Figure 36](#). The detailed pixel timing is somewhat dependent on the operating modes of the AFE circuitry regarding the number of adjustment points for the on and off points of the different timing outputs.

NOTE: In addition to the timing adjustments shown, the polarity of all sensor clock signals can be adjusted by register control.

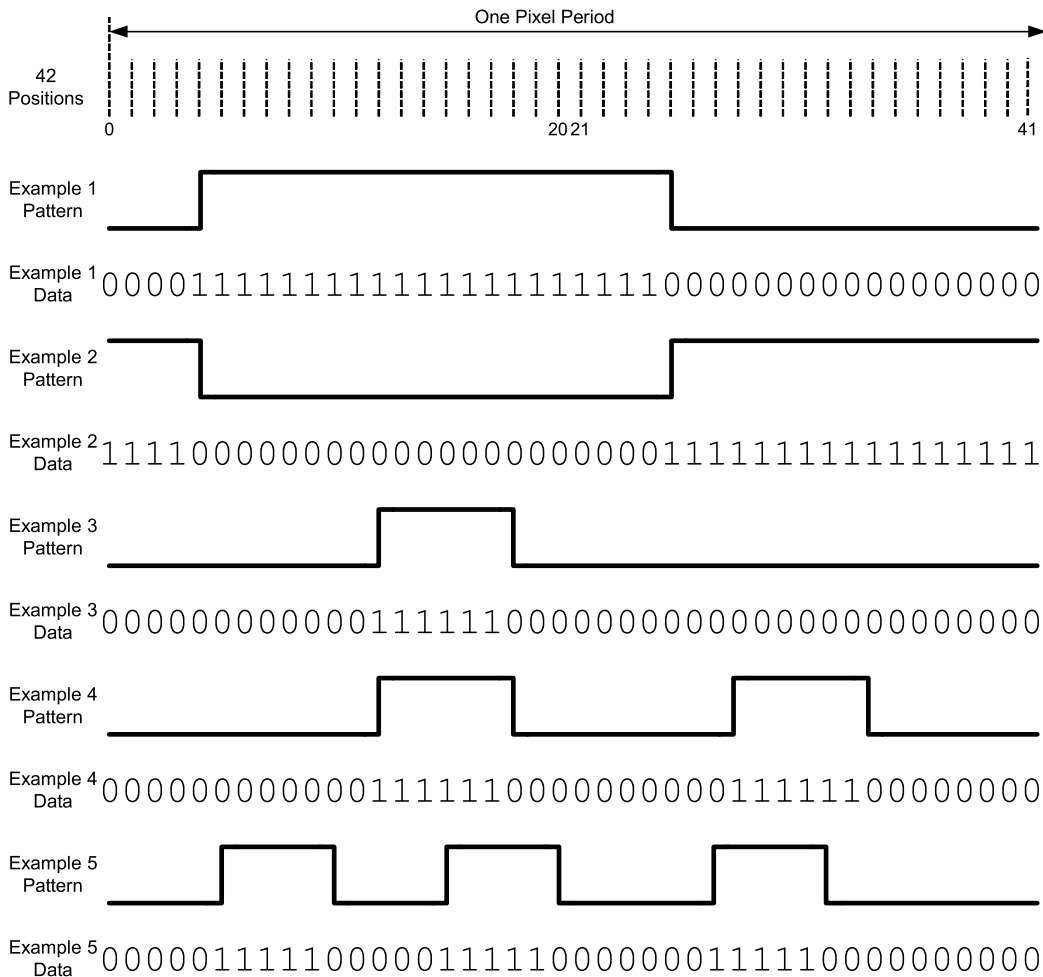

Figure 33. Pixel Timing - 42 Timing Points Per Pixel in Mode 3

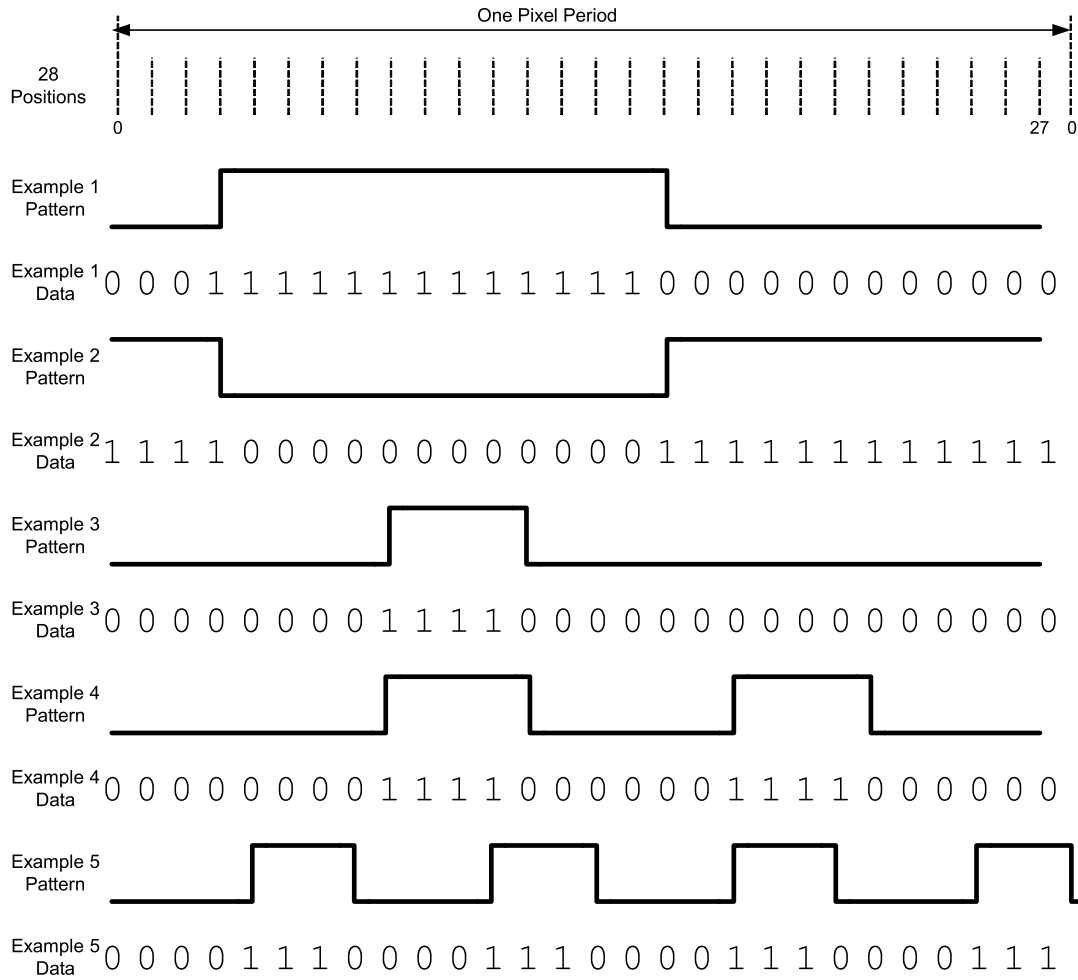

Figure 34. Pixel Timing - 28 Timing Points Per Pixel in Mode 2 and Mode 1

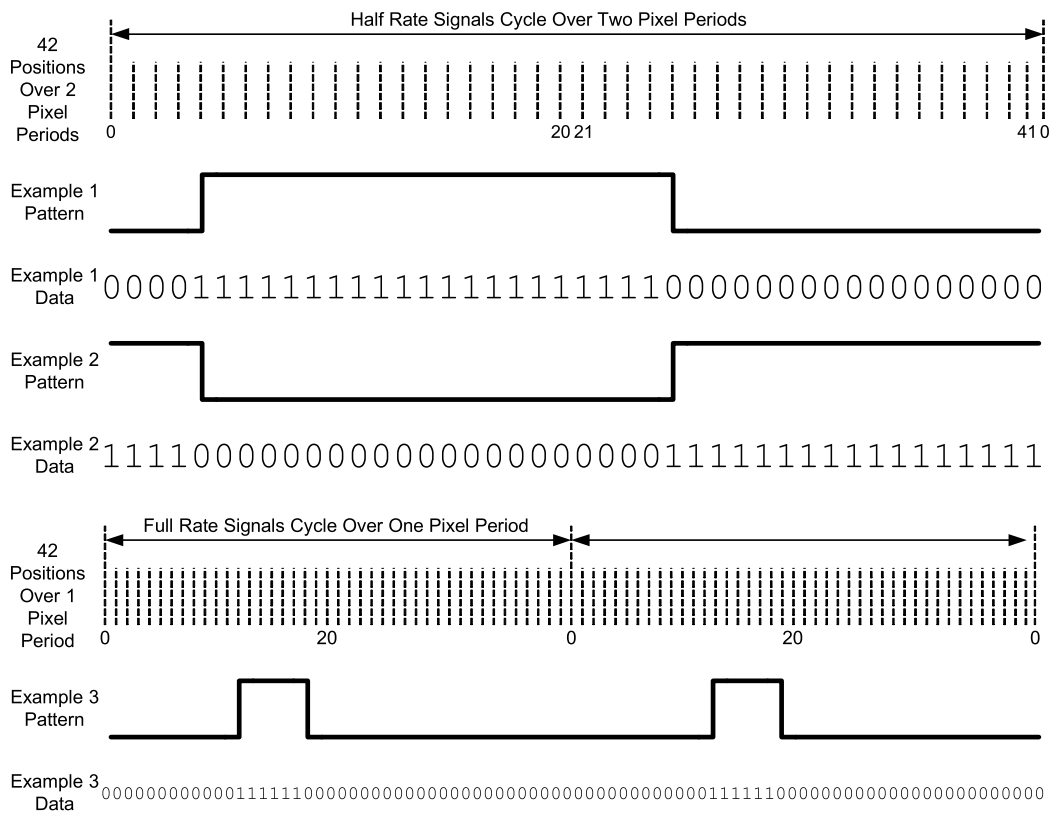

Figure 35. Pixel Timing - Normal or 1/2 Rate Timing for High Resolution Sensors

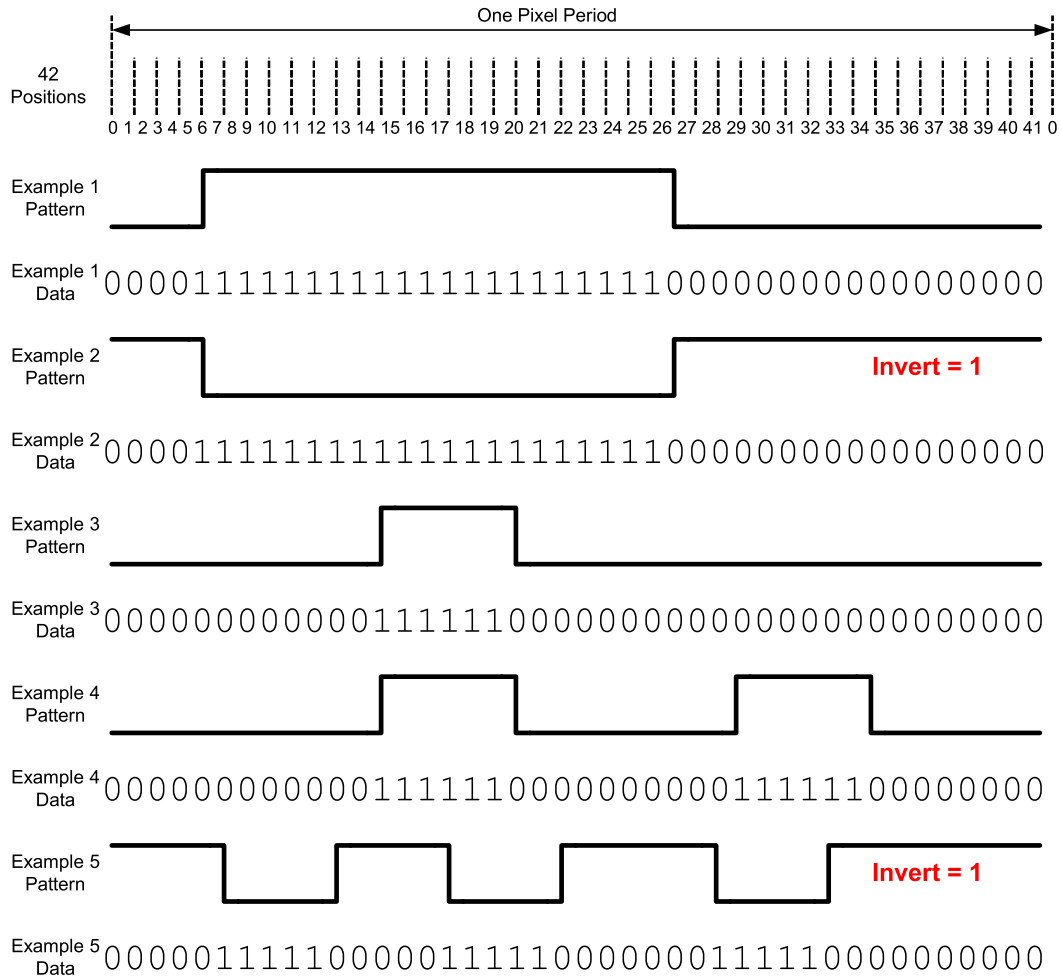

Figure 36. Pixel Timing - Independent Inversion of Each Output

7.4.14.2 SH Interval Details - Multiple States Defined within SH Interval

In the LM98725, each SH Interval (the period when the high speed pixel timing is stopped) can have a selected number of “States”, with each “State” having a specified duration. In the most common usage, each SH Interval is the same, and there can be as many as 31 defined States within the SH Interval. During each State, the logic level of each output signal can be defined as 1 or 0. The duration of the State, and the logic levels of the signals are defined in configuration registers on register pages 3, 4 and 5.

Each State basic duration can be from 1 to 255 pixel periods. There is also a multiplier of 2x, 4x, 8x or 16x (Page 2, Register 0x17) that will increase SH State durations for sensors that require long SH pulse widths.

If less than the maximum number of states are required, the first 0 duration State in the SH Interval will terminate processing. At the end of the SH Interval, a glitchless transition to pixel timing will occur. Similarly, at the end of the pixel timing, a glitchless transition to the first state in the SH Interval will occur.

Some more complex sensors require different SH Interval timing in some sequence. The LM98725 can support up to 4 different SH Interval Timings. The available 31 states are divided as follows when higher numbers of SH Intervals are used:

Table 9. States within SH Intervals

# of SH Intervals	AVAILABLE STATES			
	SH Interval 1	SH Interval 2	SH Interval 3	SH Interval 4
1	0 to 30	n/a	n/a	n/a
2	0 to 14	15 to 30	n/a	n/a
3	0 to 9	10 to 19	20 to 30	n/a
4	0 to 6	7 to 14	15 to 22	23 to 30

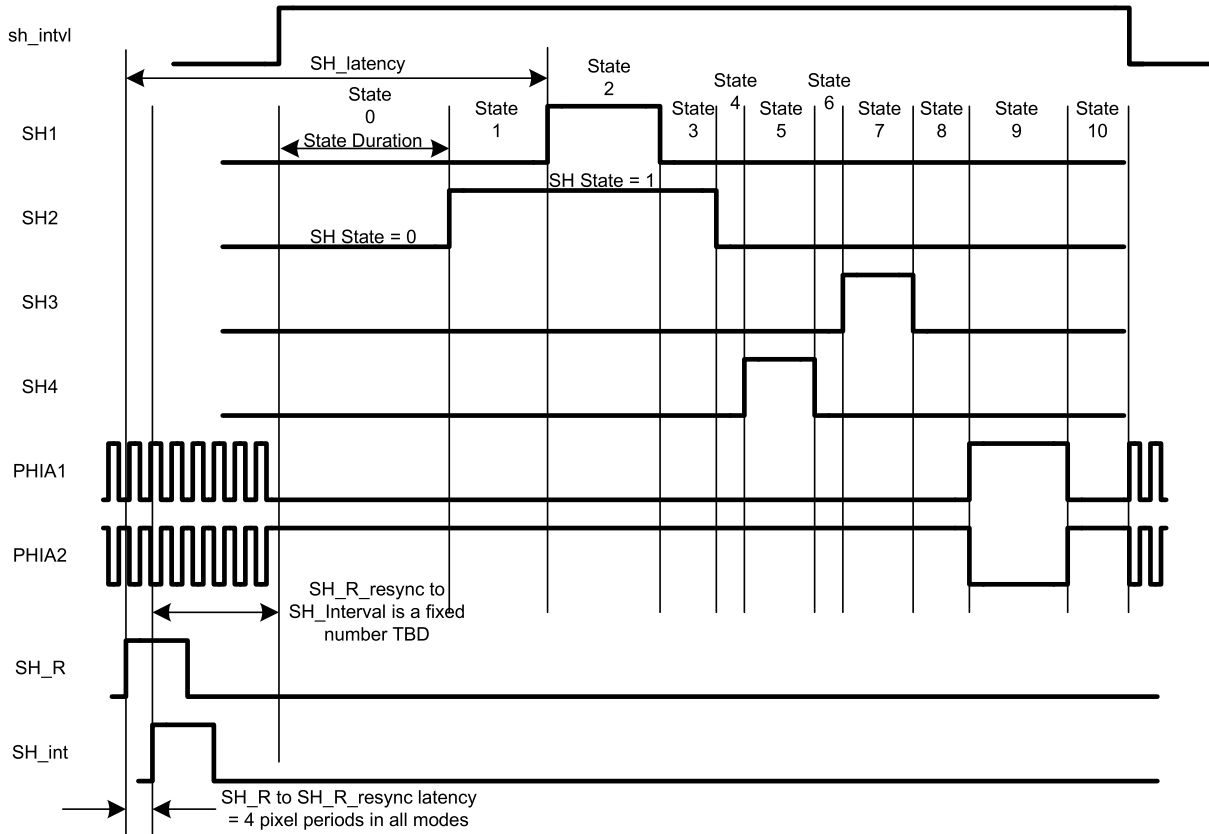

Signal levels in each SH Interval State are set by the settings "SH State x LSPIX 12-0" settings in pages 4 and 5 of the register table. The SH State settings are 1 = high. These internal signals can be inverted by the polarity settings for each signal output found in Page 7.

State Durations (in pixel periods) are set by the settings "SH State Length x" settings in page 3 of the register table and can be from 1 to 255 pixel periods.

States 0 to 30 (31 total) are supported, for a maximum SH Interval duration of $31 \times 255 = 7905$ pixel periods.

At a 22 MHz pixel rate, this will support SH intervals as long as $359 \mu\text{s}$ *(to 5.7 ms). Each SH State can be as long as $255 \times 45.455\text{ns} = 11.59 \mu\text{s}$ *(to 185 μs). *(Both of these quantities can be longer by factors of 2x, 4x, 8x, or 16x as set by Page 2, Register 16.

Processing will of SH Interval States will continue as long as subsequent State Length settings are non -zero. The first zero length State Length setting will terminate processing, and signify the end of the SH interval. In this example, the duration for SH State 11 was set to 0, so the SH Interval was complete at the end of SH State 10.

Figure 37. Sensor Timing SH Interval Details - Single SH Interval

An example showing a 4 SH Interval sequence is shown in Figure 38 through Figure 41.

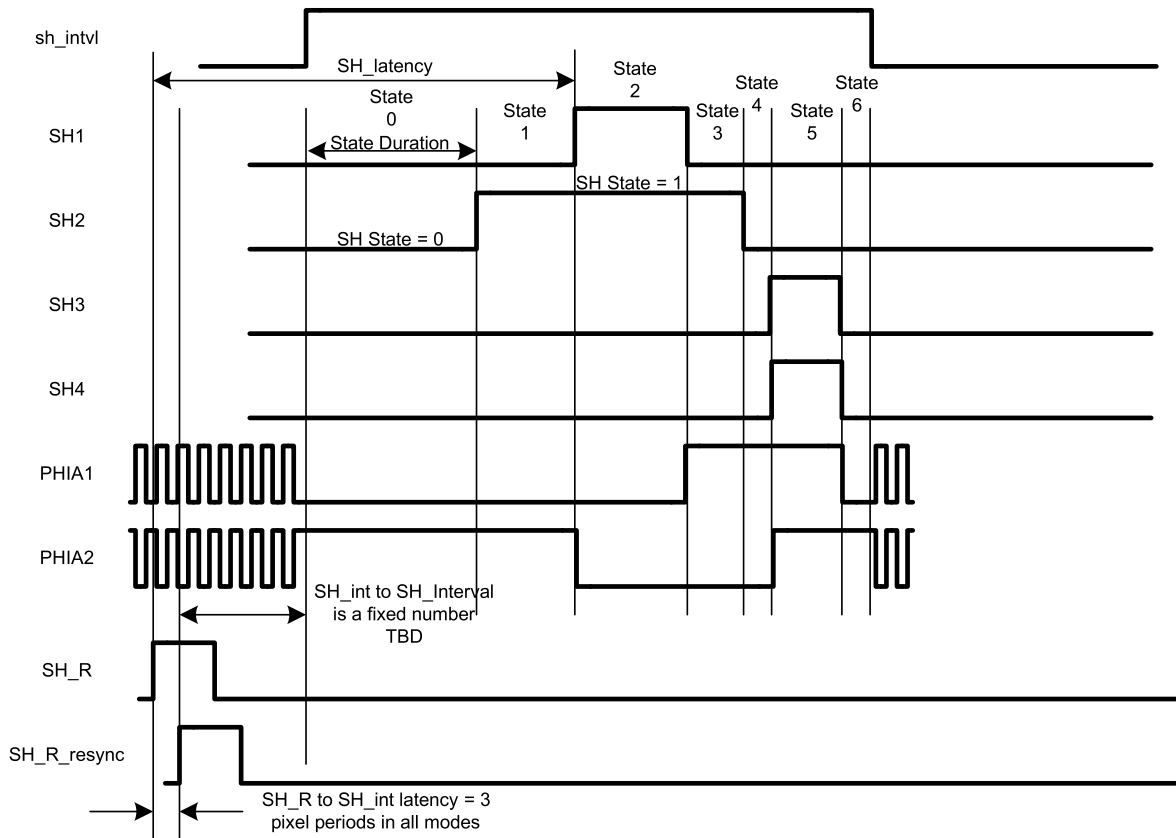

In the First SH Interval, SH States 0 to 6 are available.

Figure 38. Sensor Timing SH Interval Details - Multiple SH Intervals - 1 of 4

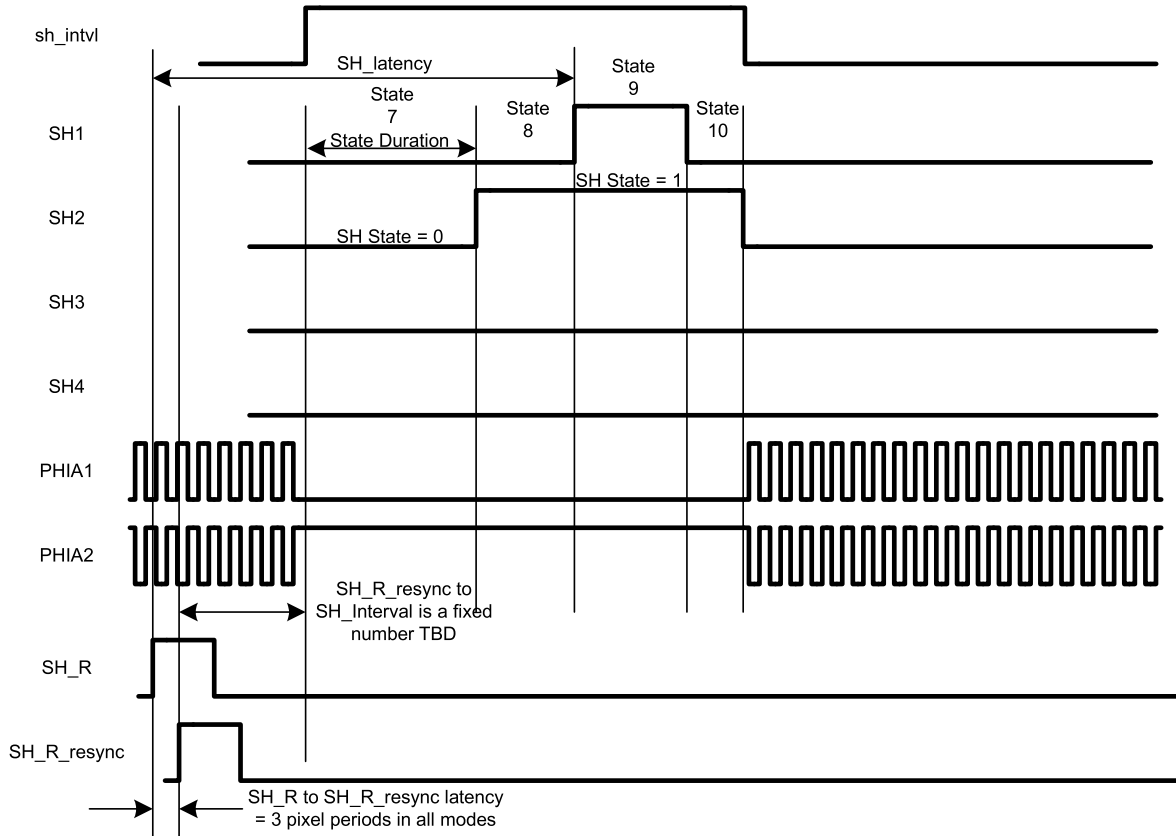

In the Second SH Interval, SH States 7 to 14 are available. The SH interval ends at the first zero length SH State. In this example, only states 7, 8, 9, 10 are used.

Figure 39. Sensor Timing SH Interval Details - Multiple SH Intervals - 2 of 4

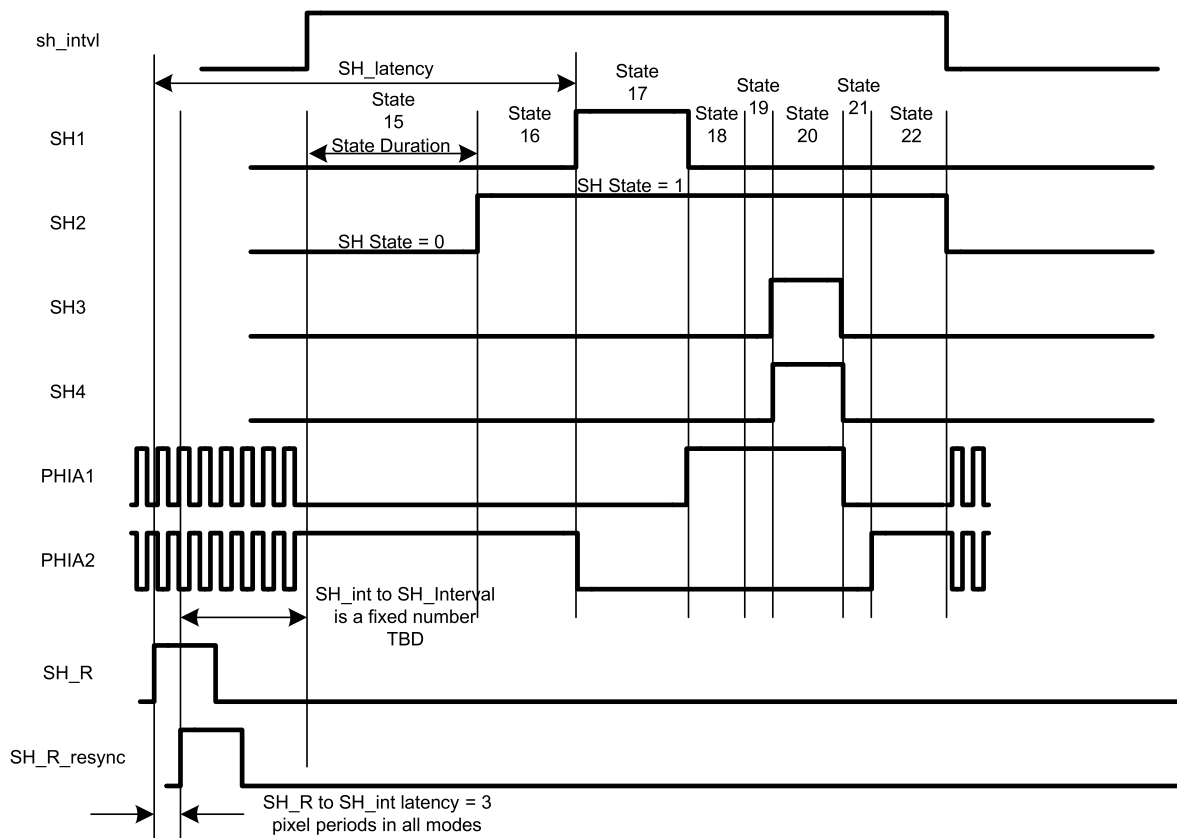

In the Third SH Interval, SH States 15 to 22 are available.

Figure 40. Sensor Timing SH Interval Details - Multiple SH Intervals - 3 of 4

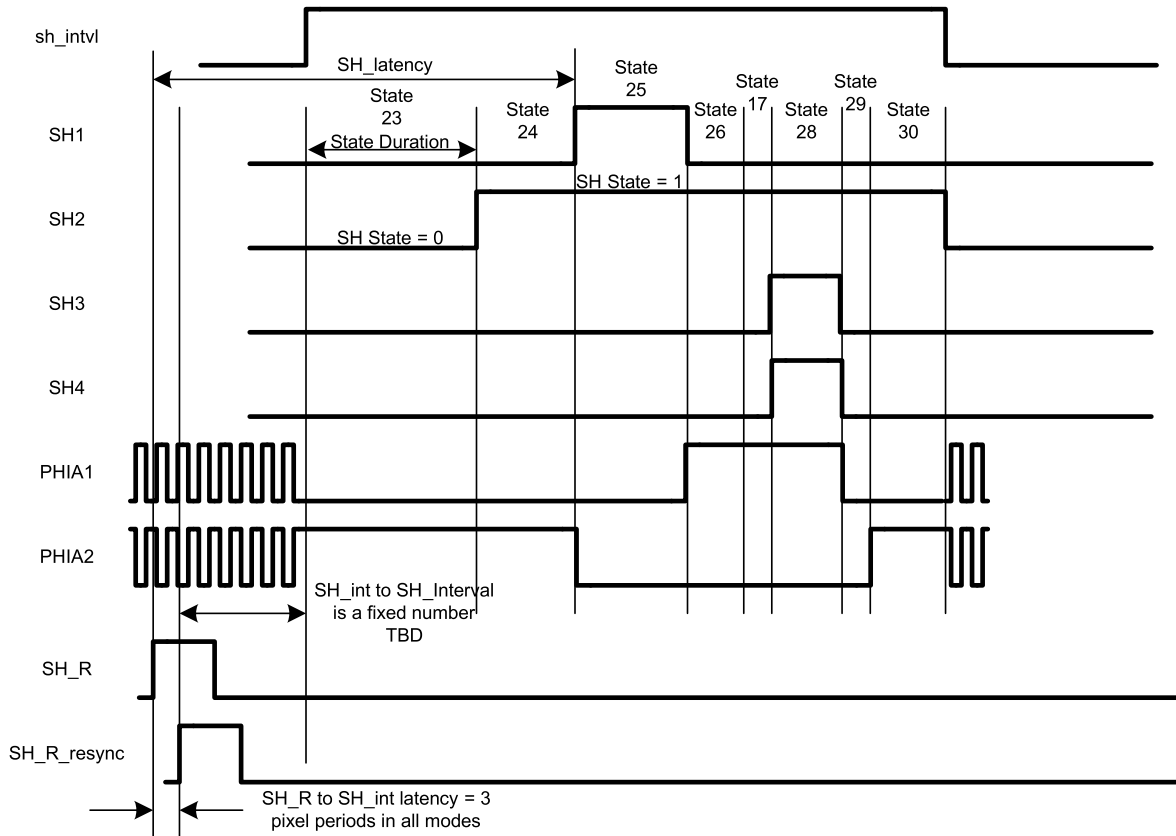

In the Fourth SH Interval, SH States 23 to 30 are available.

Figure 41. Sensor Timing SH Interval Details - Multiple SH Intervals - 4 of 4

7.4.14.3 SH Outputs - Low Speed Line Timing Usage

While the PHI, RS and CP outputs generate high speed timing during the pixel portion of the line, the SH outputs can be used to generate low frequency signals during this period. This can be useful to generate “mode” or “resolution” control signals for certain sensors.

Each SH output has a programmed ON and OFF point within the line. These points are programmed with a 16 bit value that sets the pixel number where the transition occurs.

Programming ON and OFF in different orders will allow pulses that are normally low or normally high, always high, always low, and so on. A common 1x, 2x, or 4x multiplier (Page 2, Register 0x15) can be used to increase the range (and reduce the resolution) of these ON/ OFF points, as well as the White/Active and Line Length pixels settings.

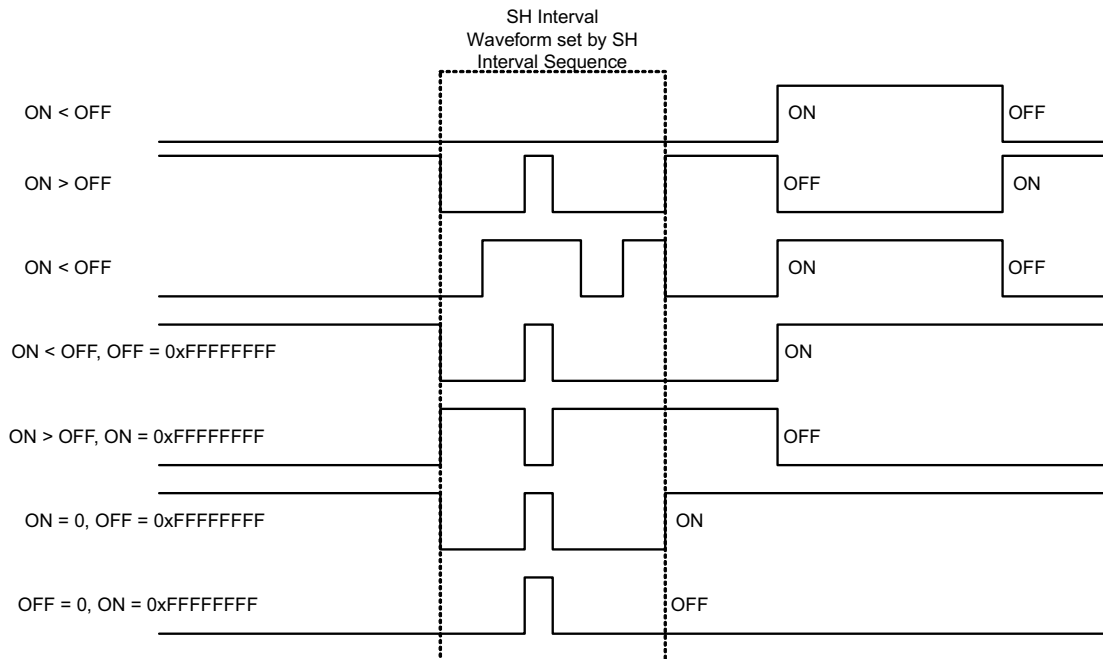
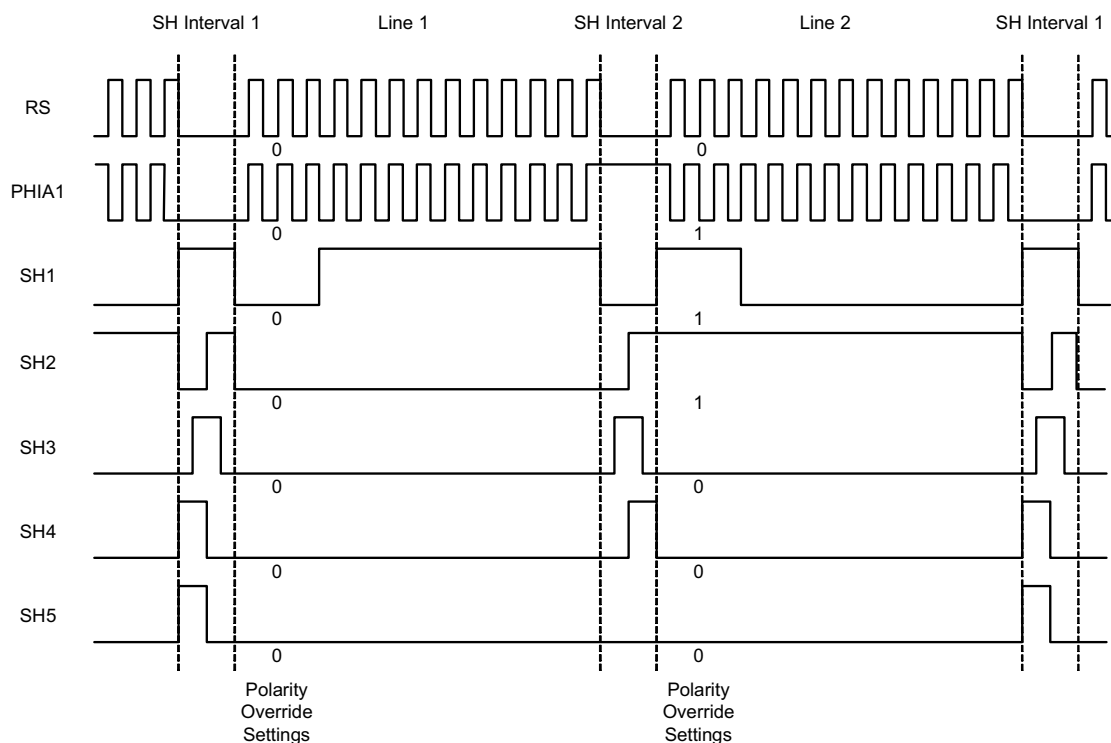

Figure 42. Sensor Timing SH ON/OFF Details - Example Settings and Waveforms

7.4.14.4 Controlled Inversion

When using multiple SH Intervals, it is possible to invert the pixel portion of the line for any of the output signals in any of the 4 Lines in the sequence. There is one bit per signal (or pair of signals for PHIA, PHIB and PHIC), for each of the 1 to 4 lines in the sequence. Setting the bit for a particular output and line in the sequence will cause the pixel portion of that line to be inverted. The transition to the next line in the sequence occurs at the end of the SH Interval. Inversion can affect both the high speed timing signals (PHIx, RS, CP) and the low speed ON/OFF behavior of the SH signals.

Below is an example of Polarity Override with a 2 Line sequence. Note that the PHIA1, SH1, SH2 and SH3 signals are inverted in Line 2, while all other signals are at the default polarity for both lines.



SH Interval signal levels are set by SH Interval Information

Polarity for pixel portion of lines can be adjusted by Polarity Override Settings – Page 7, Registers 0x14 to 0x1D

Figure 43. Sensor Timing Mode Pin Output Details - Active Programmed Transition

7.4.15 CCD Timing Generator Master/Slave Modes

The internal Sensor Timing generator is capable of operating in Master Mode or in Slave Mode. The Master/Slave operation is configured with the Master Mode Select bit (Page 0, Register 0x00, bit 1). In either Master or Slave Mode, control bit data can be included in the LM98725 output data to indicate when each new scan is starting as well as pixel information such as color, type (active, black, dummy, and so on), and the beginning of each line.

7.4.15.1 Master Timing Generator Mode

In Master Timing Mode (Page 0, Register 0x00, bit 1 = 1), the LM98725 controls the entire CCD Timing Generation based on INCLK and the Register Lock Bit (Page 0, Register 0, Bit 0) state. The Register Lock bit is set by the user to initiate a new scan. The LM98725 controls when each new line of the scan begins and ends based on the CCD Timing Generator register settings. Scanning is enabled as long as the Register Lock bit = 1. The period of the line (integration time) is controlled by the SH Interval State Length settings (Page 3 Registers) and the Line Length setting (Page 3, Registers 0x0D and 0x0E) as well as the Pixel Multiplier Factor (Page 2, Register 0x0F) and SH State Length Multiplier (Page 2, Register 0x11) .

The line period from end of one SH Interval to the end of the next SH Interval is equal to:

Line Period = (Sum of SH Interval States x SH State Length Multiplier) + (Line Length Setting x Pixel Multiplier Factor) pixels

7.4.15.2 Slave Timing Generator Mode

In Slave Timing Mode (Page 2, Register 0x00, bit 1 = 0), the LM98725 CCD Timing Generator is controlled by the external SH_R pin. Each new line of a scan is initiated by an SH_R pulse. The period of the line (integration time) is mainly controlled by the period of the incoming SH_R signal. The minimum period between SH_R pulses should be at least the SH Interval duration as calculated above, plus the number of pixels to be clocked out of the CCD or CIS sensor.

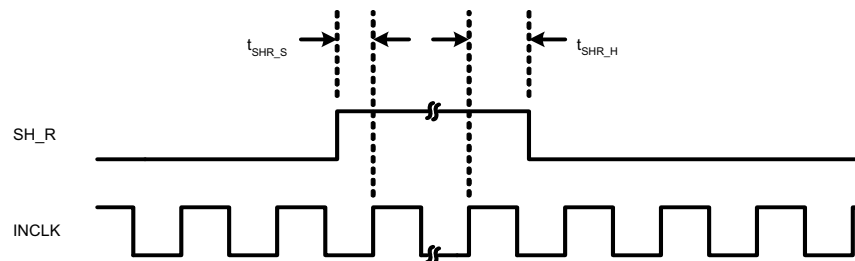

Figure 44. SH_R to INCLK (PIXCLK or ADCCLK) Timing

7.4.15.3 Multiple SH Intervals

Multiple SH Intervals are supported for those CCD sensors that has different waveform and timing requirements during successive SH Intervals. Up to 4 different SH Intervals are supported.

In the Multiple SH Interval mode, the Line Period can be different for each line, due to the possible different settings for SH Interval duration. In that case the Line Periods would be calculated as follows:

Line Period1 = (Sum of SH Interval States1 x SH State Length Multiplier) + (Line Length Setting x Pixel Multiplier Factor) pixels

Line Period2 = (Sum of SH Interval States2 x SH State Length Multiplier) + (Line Length Setting x Pixel Multiplier Factor) pixels

Line Period3 = (Sum of SH Interval States3 x SH State Length Multiplier) + (Line Length Setting x Pixel Multiplier Factor) pixels

Line Period4 = (Sum of SH Interval States4 x SH State Length Multiplier) + (Line Length Setting x Pixel Multiplier Factor) pixels

In multiple SH Interval mode, the SH Interval States are subdivided as follows:

Table 10. SH Interval States Subdivision

# SH INTERVALS	SH INTERVAL 1 STATES	SH INTERVAL 2 STATES	SH INTERVAL 3 STATES	SH INTERVAL 4 STATES
1	0 to 30			
2	0 to 14	15 to 30		
3	0 to 9	10 to 19	20 to 30	
4	0 to 6	7 to 14	15 to 22	23 to 30

7.4.15.4 Support for CIS Sensors

In CIS Sensor modes, the SH (LampR), SH2 (LampG), SH3 (LampB) and SH4 (LampIR) outputs are configured as Lamp illumination control outputs. In CIS mode, the number of lines/colors in the lamp sequence is selected by the Multiple SH Interval setting at Page 2, Register 10h, Bits 1:0. Sequences of 2, 3 or 4 lines/colors are supported in CIS mode. By definition, the standard CCD timing mode is equivalent to a CIS mode with length = 1.

Two different CIS modes are supported (CISa and CISb, selected at Page 2, Register 0x10h, Bits 4:3):

In CISa, there can be 2, 3 or 4 colors in the sequence, to support sensors with as many as 4 different lamp colors. In this mode, the PGA and DAC settings are controlled by the channel settings, regardless of what line in the sequence is being processed.

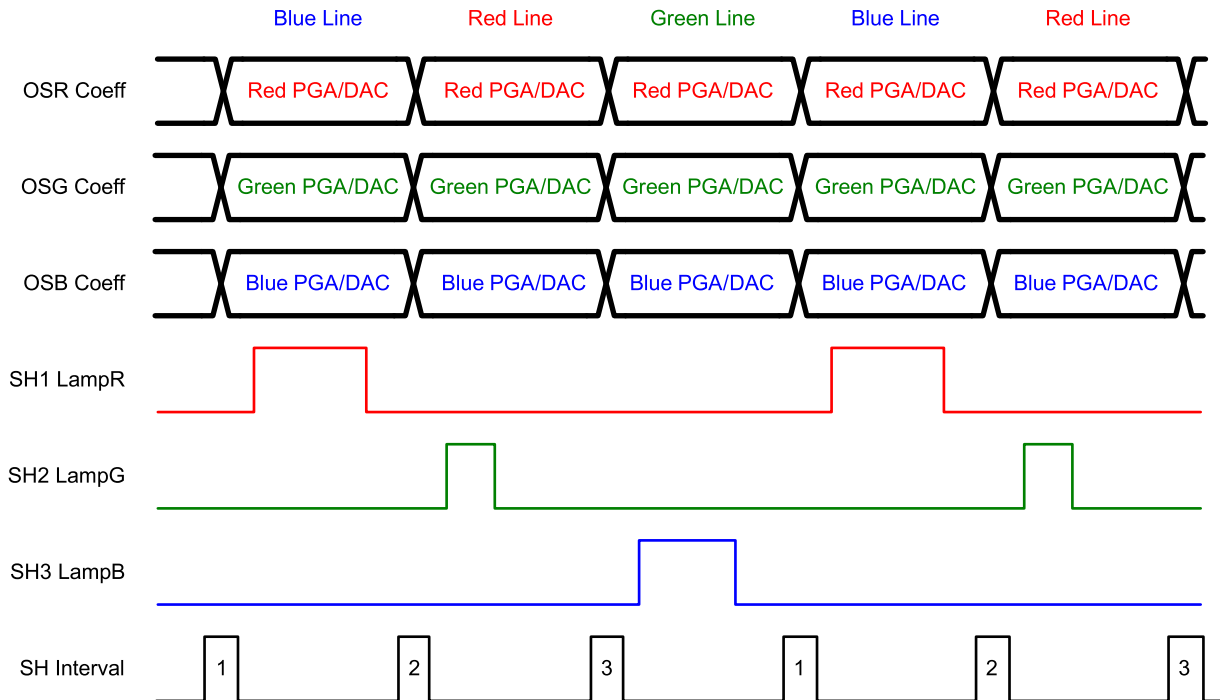

Figure 45. Mode 3, 3 Color Sequence, CISa Default

In CISb, there are 2 or 3 colors in the sequence. In this mode, the PGA and DAC settings are controlled by the color in the sequence that is being processed. For example, when a Red line of data (exposed using the SH1 or LampR output) is being processed, the Red channel PGA and DAC settings are used for all input channels. When the SH2/LampG (Green) line of data is being processed, the Green PGA and DAC settings are used for all input channels. and so on.

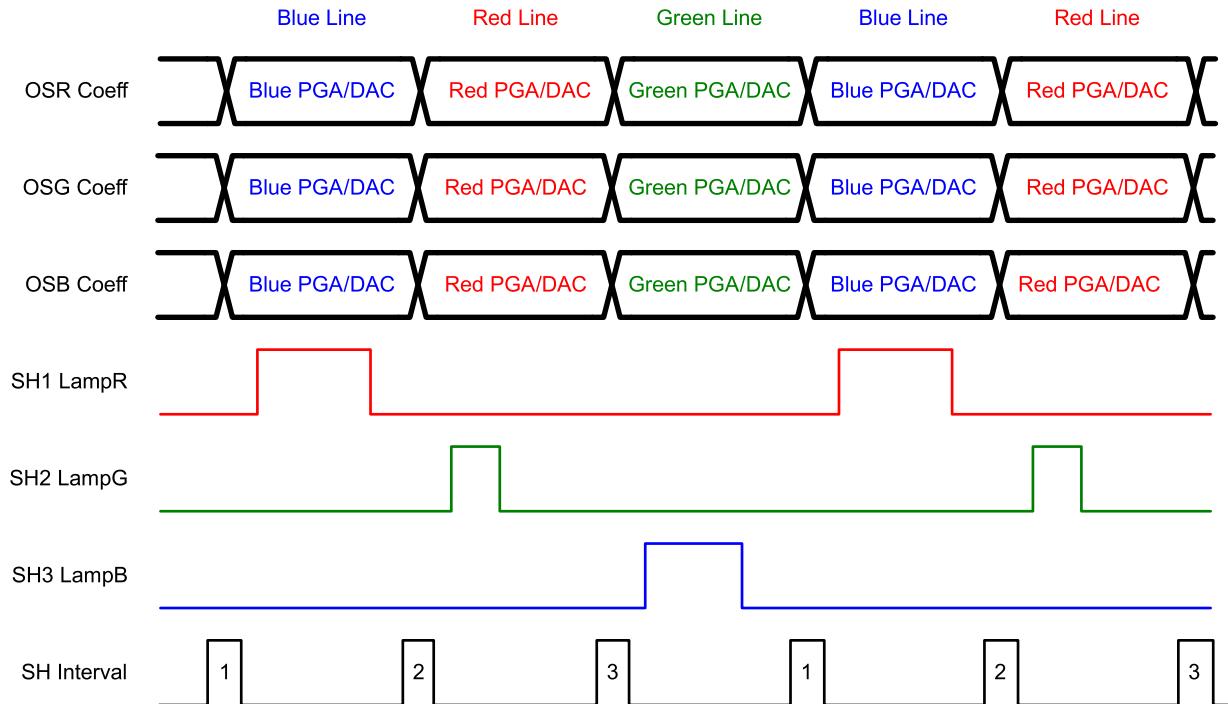
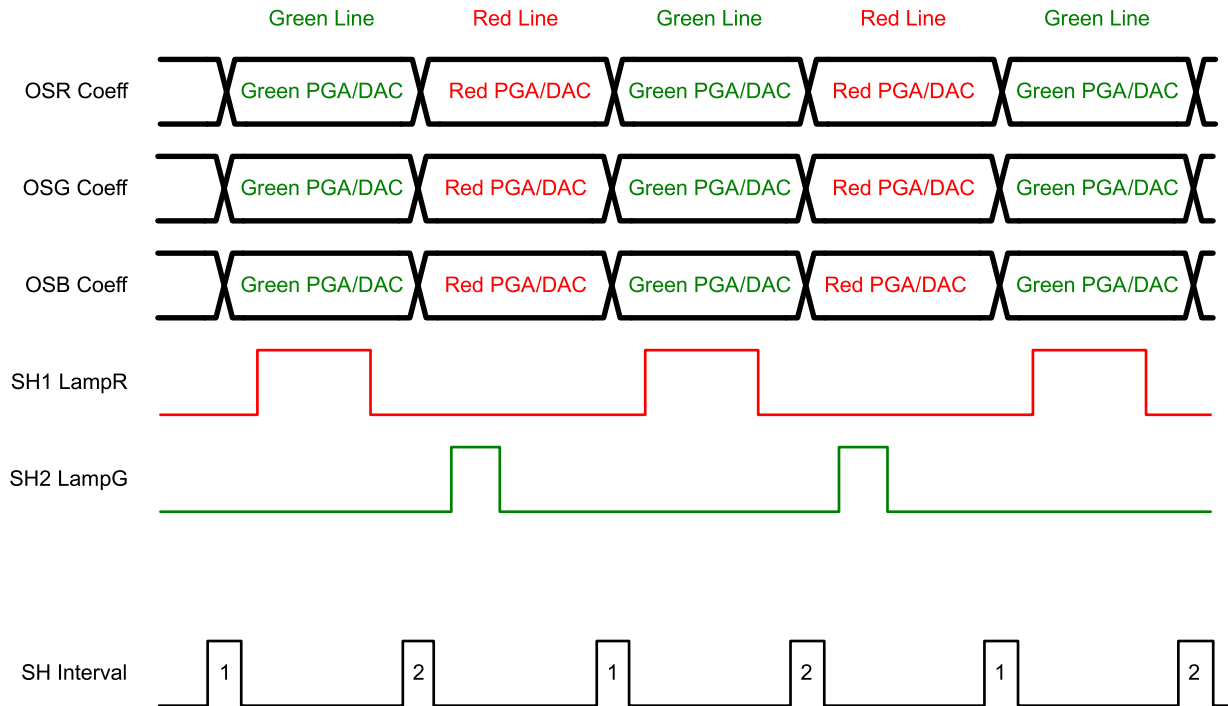

Figure 46. Mode 3, 3 Color Sequence, CISb

In CISb, when a 2 line sequence is selected, it is necessary to choose which coefficients are used during the 2 different lines in the sequence. this selection is made with the CISb Color Coefficient Select at Page 2, Register 10h, Bits 6:5. Following is an example of a 2 color sequence, where Red and Green are the selected colors:



Use Page 2, Register 10h, Bits 6:5 to choose which SHx Lampx outputs are used, and which coefficients are used in CISb 2 color sequence.

Figure 47. Mode 3, 2 Color Sequence, CISb

To support monochrome scanning with an RGB CIS, select Mode 3, and a 1 line sequence. The LampR, LampG and LampB On/Off times will apply for every line. The On/Off times and relative channel gains can both be adjusted to achieve the desired white balance. Lamps can be on either simultaneously if the CIS and power budget allow, or sequentially.

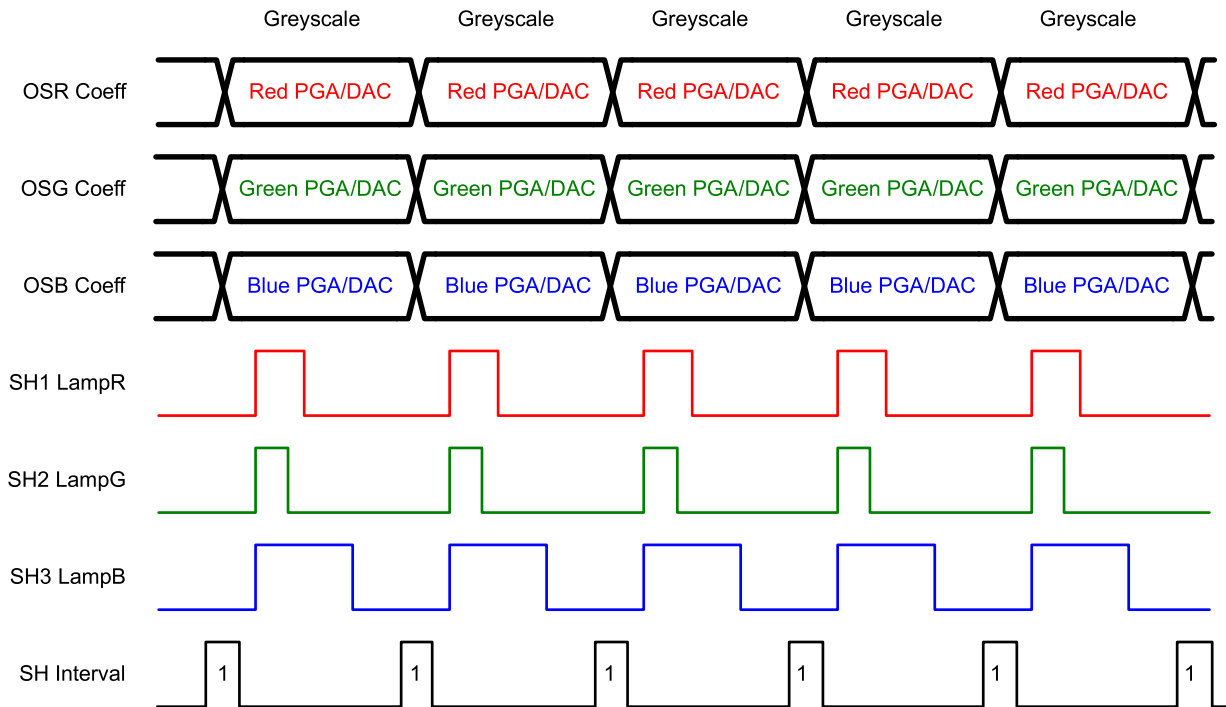

Figure 48. Mode 3, Mono – 1 Color, CCD Timing Lamps can be on simultaneously , or sequentially within each line

7.4.15.5 LVDS Output Format - LM98714 Mode

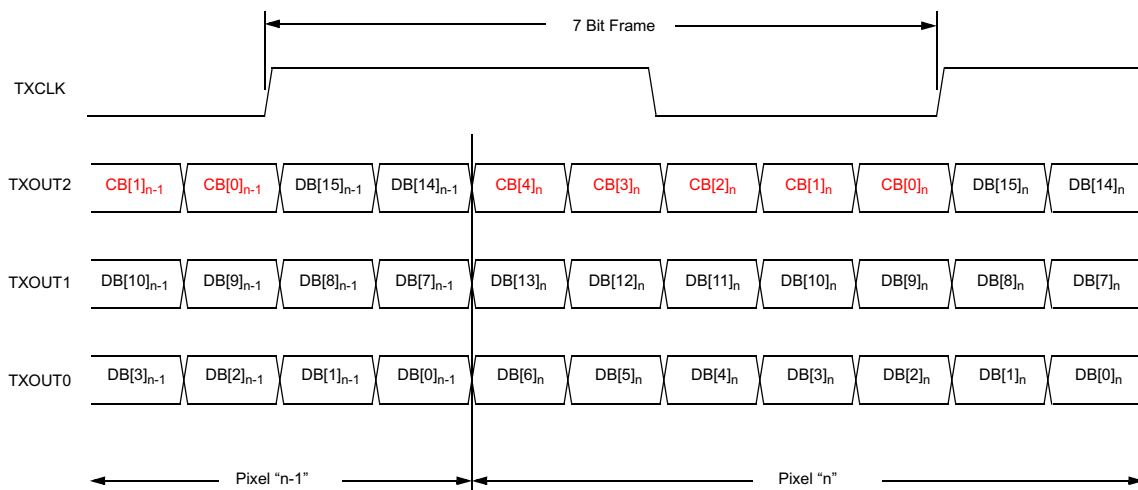

Figure 49. LVDS Output Bit Alignment and Data Format

7.4.16 LVDS Control Bit Coding - LM98714 Mode

The 5 control bits included in the LVDS data stream are coded as follows:

The "active" and "black" pixel tags are programmable tags that the LM98725 provides in order to identify how many pixels have been processed since the falling edge of SH.

Which pixels are given "Active" and "Black" CB tags is controlled by Page 2, Registers 0x02, 0x08-0x0C, and 0x0F. (# Black Pixels Averaged, Black Pixels Start, Active/White Pixels Start, Active/White Pixels End, and Line Length Multiplier).

The LM98725 counts the number of pixel periods after the SH Interval: If the number of pixel periods after the SH Interval is greater than (Black Pixels Start) and less than (Black Pixels Start + # Black Pixels Averaged) the CB bits will indicate that the pixel is a Black pixel. If the number of pixel periods after the falling edge of SH is between Active/White Pixels Start and Active/White Pixels End, the CB bits will indicate that the pixel is an Active pixel.

7.4.16.1 Latency Compensation of CB Bits

By default, the CB bits will be compensated for the latency through the AFE signal chain. This compensation can be turned off by setting Page 8, Register 0x08, Bit 2 = 1.

Table 11. Latency Compensation of CB Bits, CB[4]

CB[4]	DESCRIPTION
0	Not the beginning of line
1	Beginning of Line (This bit is high during the SH Interval)

Table 12. Latency Compensation of CB Bits, CB[3:0]

CB[3:0]	DESCRIPTION
0000	Dummy Pixels
0001	Red Active Pixels
0010	Green Active Pixels
0011	Blue Active Pixels
0100	IR1 Active Pixels
0101	IR2 Active Pixels
0110	Red Black Pixels
0111	Green Black Pixels
1000	Blue Black Pixels
1001	IR1 Black Pixels
1010	IR2 Black Pixels
1111	Beginning of Scan (This bit is high during the SH Interval of the first line after the Lock Bit transitions from low to high)

7.4.17 Flexible LVDS Formatting Mode: Mapping

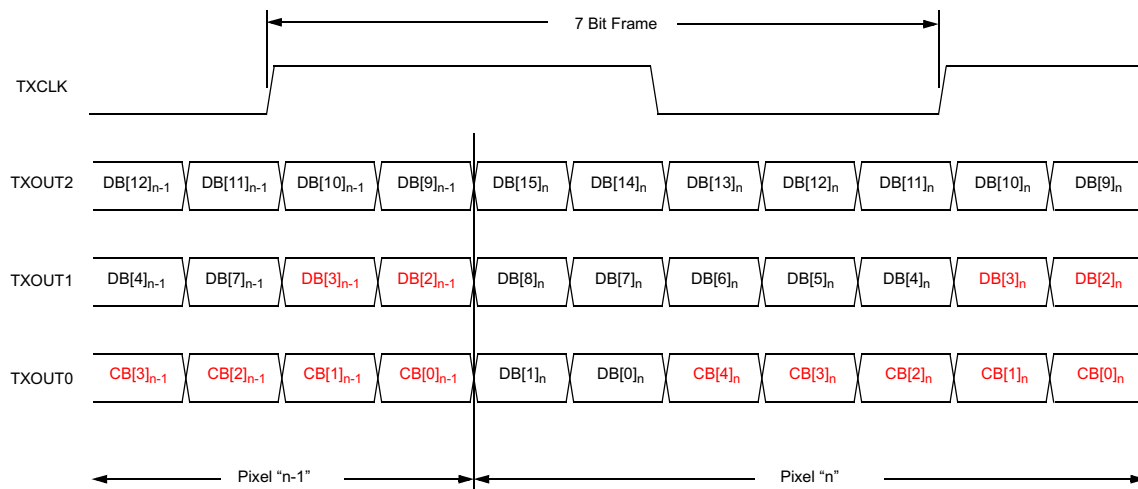

Figure 50. LVDS Output Bit Alignment and Data Format

In Flexible LVDS Formatting Mode, the values highlighted in red can be substituted with other CB tag information. The table below shows the different CB information that can be selected:

Table 13. Selectable CB Tag Information

SETTING	CB TAG INFORMATION
0000	Original CB or Data
0001	CBO0 from LM98714 definition
0010	CBO1 from LM98714 definition
0011	CBO2 from LM98714 definition
0100	CBO3 from LM98714 definition
0101	CBO4 from LM98714 definition
0110	R - High for a red channel pixel
0111	G - High for a green channel pixel
1000	B - High for a blue channel pixel
1001	Parity - 21 bit if TXOUT0 Enabled, 14 bit if TXOUT0 Disabled
1010	Ping - High for pixels processed by the Ping section of a channel, low for Pong
1011	Line# lsb - Line = 0 to 3 for lines 0 to 3 in multiline sequences
1100	Line# msb
1101	Black Loop Pixels - High for pixels processed by the Black Loop
1100	White Loop Pixels - High for pixels process by the White Loop
1111	CLP Pixels - High for pixels where the input CLP switch is closed

7.4.17.1 TXOUT0 Disable

The TXOUT0 data pair can be disabled. In combination with the new Flexible LVDS Formatting Mode, this can support applications where only the upper 14 MSB of data are required. This will save one pair of LVDS wires in the cable, and reduce the LM98725 slightly.

In addition, if fewer than 14 bits are required, the D2 and D3 bits can be replaced with the desired CB information, selected from the above table.

7.4.17.2 Parity

A parity bit is available for use as one of the CB bits. Parity is calculated based on all bits being sent via the 21 or 14 bit LVDS link except:

- If any bit is selected to transmit CB Parity, it will not be used in the calculation
- If any bit is transmitting a scrambler key bit when scrambler mode 2 is selected, it will not be used in the calculation.

The total parity across the 21 or 14 output bits (excluding any scrambler key bit) will be even.

7.4.17.3 Latency Compensation of CB Bits

By default, the CB bits will be compensated for the latency through the AFE signal chain. This compensation can be turned off by setting Page 8, Register 0x08, Bit 2 = 1.

7.4.18 LVDS Data Randomization for EMI Reduction

While LVDS transmissions will inherently reduce the amount of electromagnetic energy, further reductions can be achieved by randomizing the data being sent over the link. A built in “scrambler” feature provides a number of different modes to suit different applications and host processing capabilities. One key part of the scrambler is a linear feedback shift register (LFSR) implementation to provide pseudo-random sequence “keys” to randomize the image data. The basic implementation of an LFSR is shown below:

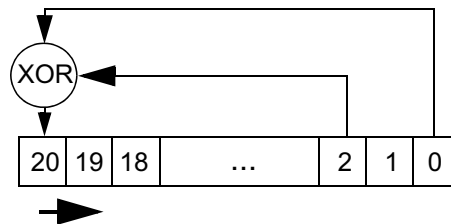

Figure 51. LFSR Implementation

LM98725

SNAS474H–APRIL 2009–REVISED MARCH 2015

www.ti.com

The LFSR algorithm used in the LM98725 is an n=21 maximal length right-shift implementation as shown above. As a reference for FPGA and ASIC developers, the sequence is the same as that created by the Synopsys DW component DW03_lfsr_load with inverted outputs. The preload or starting value for the sequence is 0x000001h.

If the prs (serial-type) output is selected (MODE = 01, SUB_MODE = 0X), the 21 bits of the LFSR are shifted one position to the right on each TXCLK.

For clarity, the first 11 values in the prs sequence are:

```
0x000001h
0x100000h
0x080000h
0x040000h
0x020000h
0x010000h
0x008000h
0x004000h
0x002000h
0x001000h
0x000800h
```

If the pprs (parallel-type) output is selected (MODE = 01, SUB_MODE = 1X), the next 21 coefficients of the shift-in term are calculated in parallel, and the LFSR is loaded with these coefficients: the effect is equivalent to clocking the LFSR 21 times in serial mode. For clarity, the first 11 values in the pprs sequence are:

```
0x000001h
0x080001h
0x020001h
0x0A8001h
0x002001h
0x082801h
0x022201h
0x0AA81h
0x000021h
0x080029h
0x120023h
```

A summary and description of each of the modes and submodes is shown in [Table 14](#).

Table 14. Mode and Submode Summary

MODE PAGE 0 REGISTER 0x05 BITS 4:3	SUB_MODE PAGE 0 REGISTER 0x05 BITS 2:1	DESCRIPTION
00		Scrambler Disabled
01		full scrambler enabled. sub-mode settings select:
	00	send lvds_data[20:0] bitwise XOR with prs[20:0]
	01	send prs[20:0]
	10	send lvds_data[20:0] bitwise XOR with pprs[20:0]
10	11	send pprs[20:0]
		1 bit scrambler with key of prs[0] send lvds_data[20:0] bitwise XOR with prs[0], with lvds_data[k] = 0 send prs[0] on lvds_out[k] k is selected with following settings:
	00	k = 0 (DB0 in CMOS and 714 modes, CB0 in flexible, 16 bit mode)
	01	k = 5 (DB0 (LSB) in flexible, 16 bit mode)
	01	k = 7 (DB2 (LSB) in flexible, 14 bit mode)
10	k = 16 (CB0 in 714 mode)	
11	k = 20 (CB4 in 714 mode)	
11		1 bit scrambler with key of lvds_data[k]. send lvds_data[20:0] bitwise XOR with lvds_data[k] with lvds_out[k] = lvds_data[k]
	00	k = 0 (DB0 in CMOS and 714 modes, CB0 in flexible, 16 bit mode)
	01 (TXOUT0 Disable = 0)	k = 5 (DB0 (LSB) in flexible, 16 bit mode)
	01 (TXOUT0 Disable = 1)	k = 7 (DB2 (LSB) in flexible, 14 bit mode)
	10	k = 16 (CB0 in 714 mode)
11	k = 20 (CB4 in 714 mode)	

7.4.18.1 Mode 00: Scrambler Disabled

Mode 00: Scrambler Disabled

7.4.18.2 Mode 01: Full Scrambler Using the full 21-bit Pseudo Random Sequence

There are 4 sub-modes: (a) the 21-bit output will be bit-wise XORed with the 21-bit serial pseudo-random sequence. that is, $lvds_data[20:0] \wedge prs[20:0]$; (b) the 21-bit serial pseudo random sequence will be output directly; (c) the 21-bit output will be bit-wise XORed with the 21-bit parallel pseudo-random sequence. that is, $lvds_data[20:0] \wedge pprs[20:0]$; (d) the 21-bit parallel pseudo random sequence will be output directly. In all sub-modes, the sequences start m clock cycles after the de-assertion of the bol where m is defined as the analog latencies in 1-ch, 2-ch and 3-ch modes. In other words, the output starts the same way as the up-count test pattern mode. Unlike the up-count test pattern mode, the 21-bit pseudo-random sequence runs at the ADC (same as TXCLK) rate, not pixel or line rate.

7.4.18.4 Mode 11: “LSB” Scrambler

The “LSB” selected from lvds_data[k] is used to scramble the output. The lvds_data[20:0] key bit k, as selected in Mode 10 above is used (as the “LSB”) to XOR the other bits. The key bit itself is not replaced.

7.4.18.5 Scrambler Inhibit Bit Select

This feature allows individual bits in the LVDS output stream to be non-scrambled. This can be used as a setup and debugging aid during initial system development, or as a permanent feature to simplify the data decoding task. The tradeoff will be somewhat compromised EMI reduction over a fully scrambled LVDS data stream.

The controls for this feature are located as follows:

Scrambler Inhibit 0 - Page 8, Register 0x12h, Bits 6:0 - LVDS[6:0]

Scrambler Inhibit 1 - Page 8, Register 0x13h, Bits 6:0 - LVDS[13:7]

Scrambler Inhibit 2 - Page 8, Register 0x14h, Bits 6:0 - LVDS[20:14]

7.4.19 LVDS Drive Strength Adjust

The LVDS outputs may be decreased in strength to reduce EMI generation, or increased in strength to improve noise immunity.

Page 8, Register 8, Bits 5:4 can be adjusted as follows (in terms of VOD into 100 Ω termination):

Table 15. LVDS Strength

00	Decrease of approximately 100 mV
01	Decrease of approximately 50 mV
10	Default - approximately 350 mV
11	Increase of approximately 50 mV

7.4.20 LVDS Output Timing Details

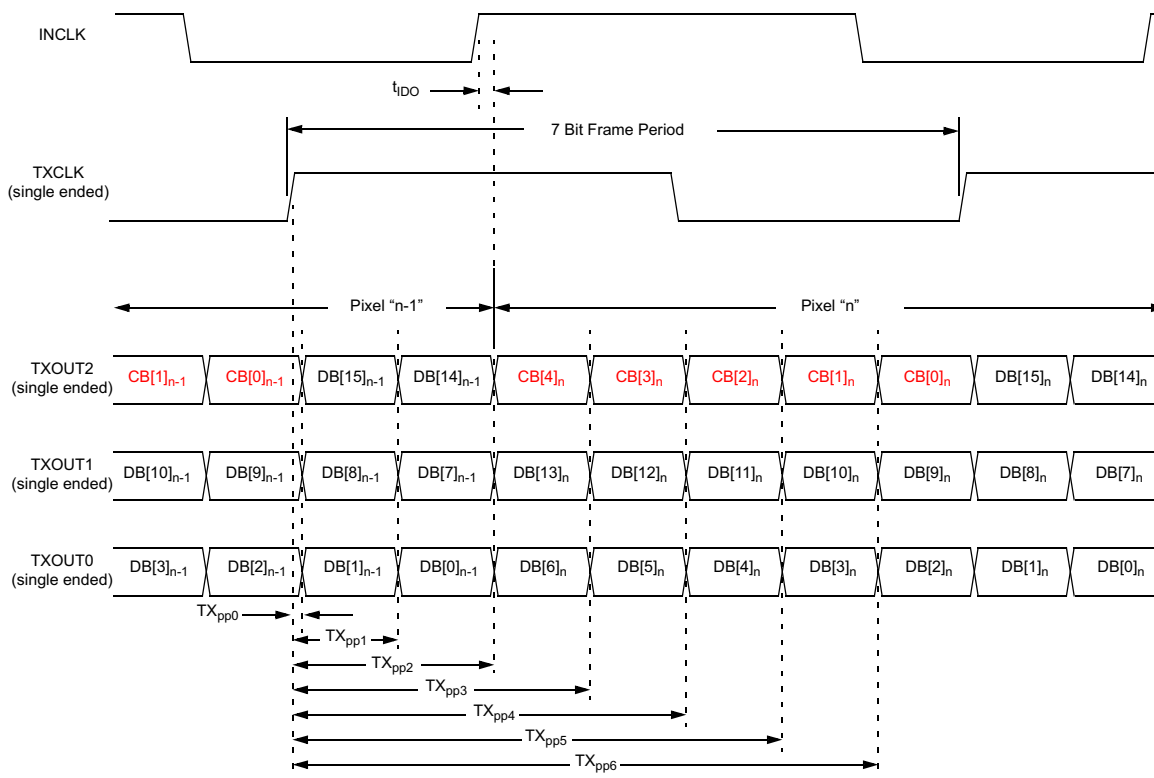
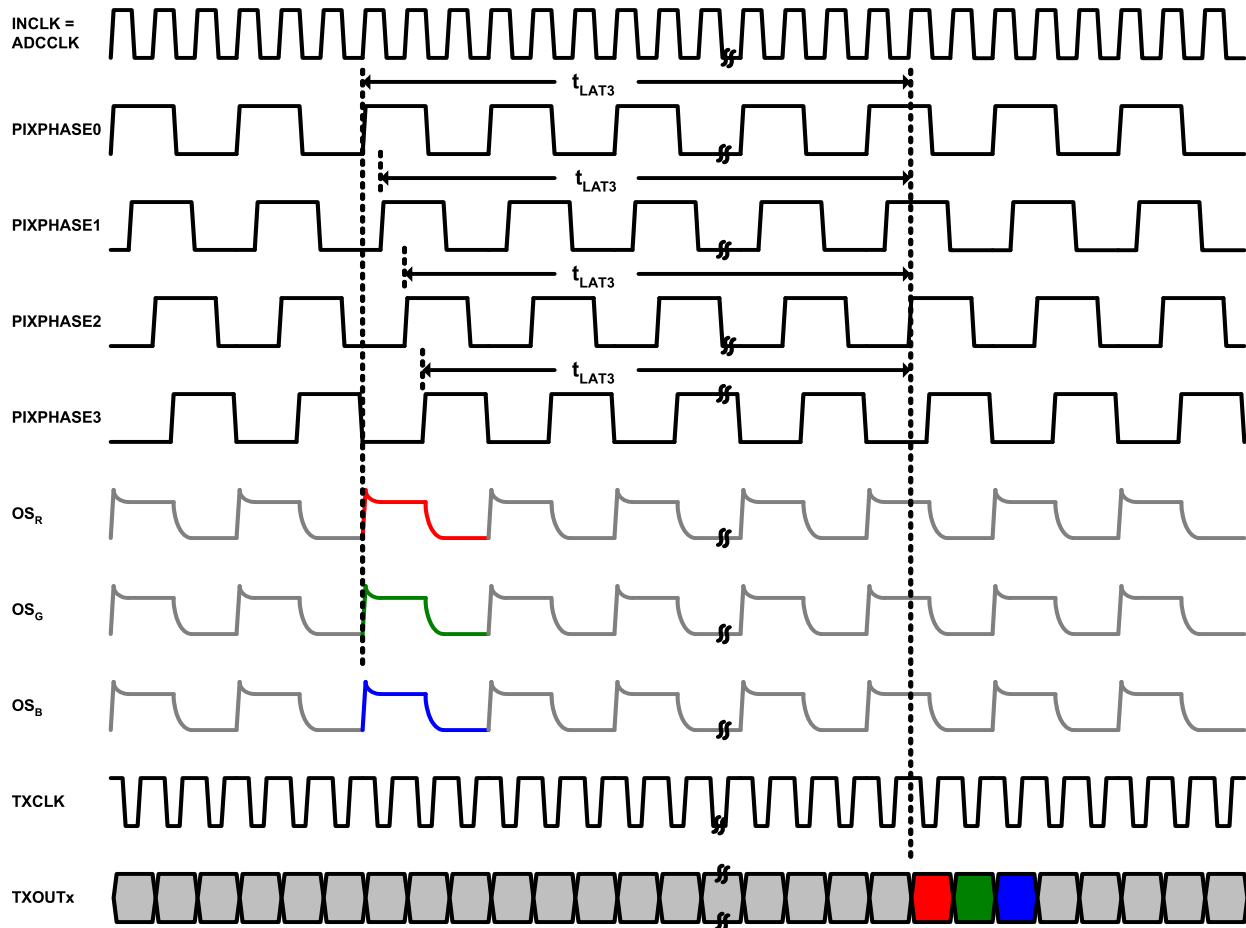

Figure 53. LVDS Data Output Mode Specification Diagram

7.4.20.1 Optional TXCLK Delay

The LM98725 includes a selectable (off by default) delay of TXCLK. This delay can be enabled (Page 8, Register 0x08, Bit 3) to improve timing margin between the TXCLK and TXOUTx signals when using certain LVDS deserializers. The default/off setting is intended to be compatible with the LM98714 LVDS timing.

7.4.21 LVDS Data Latency Diagrams



Data latency shown is for Mode 3 in relation to PIXPHASE0 with the processing order set to $OS_R \rightarrow OS_G \rightarrow OS_B$. If the incoming pixels are not aligned with PIXPHASE0, one of the remaining PIXPHASEs can be selected as the sampling phase without effecting the output data location.

Figure 54. Mode 3 LVDS Data Latency

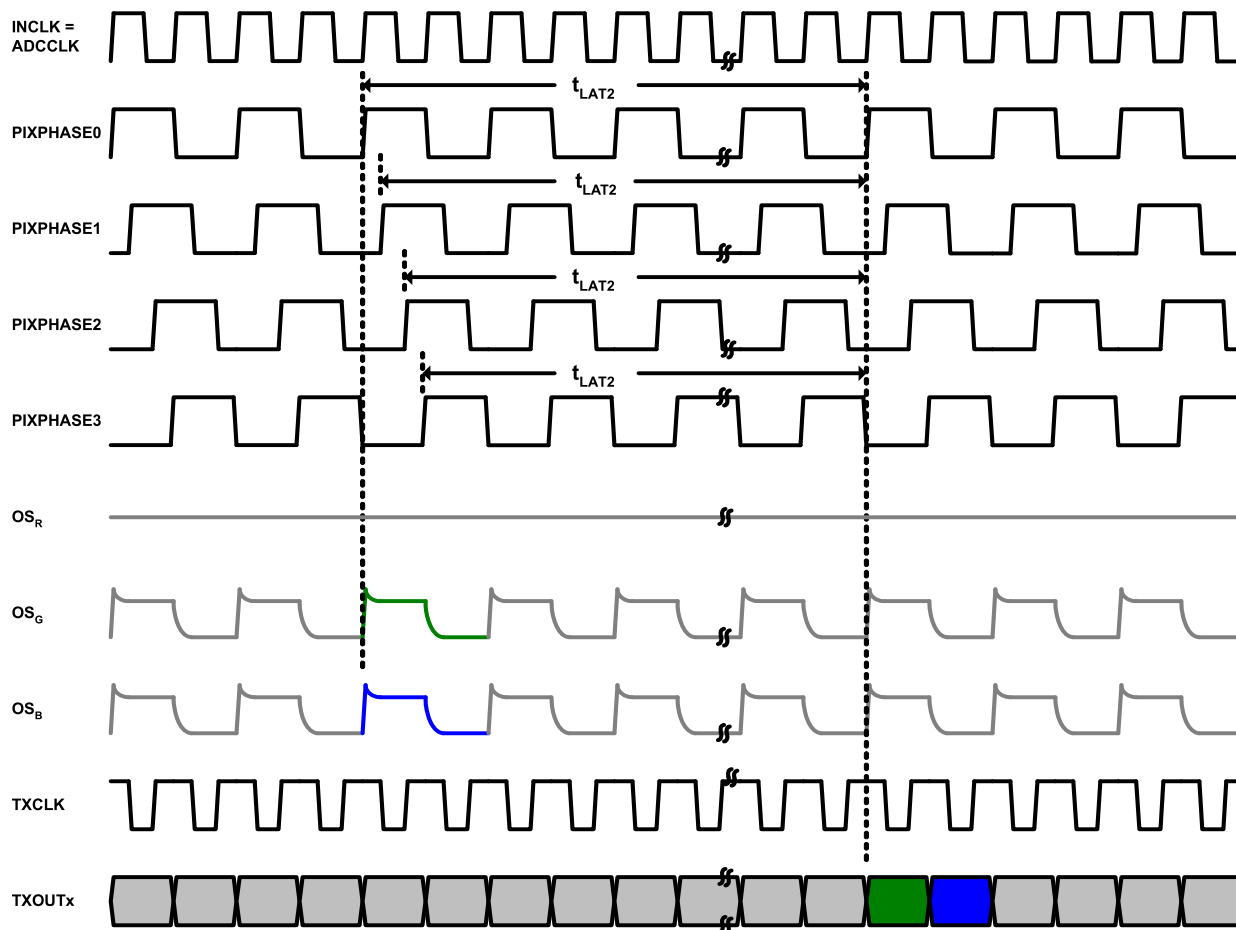

Data latency shown is for Mode 2 in relation to PIXPHASE0 with the processing order set to OS_g↔OS_b. If the incoming pixels are not aligned with PIXPHASE0, one of the remaining PIXPHASEs can be selected as the sampling phase without effecting the output data location.

Figure 55. Mode 2 LVDS Data Latency

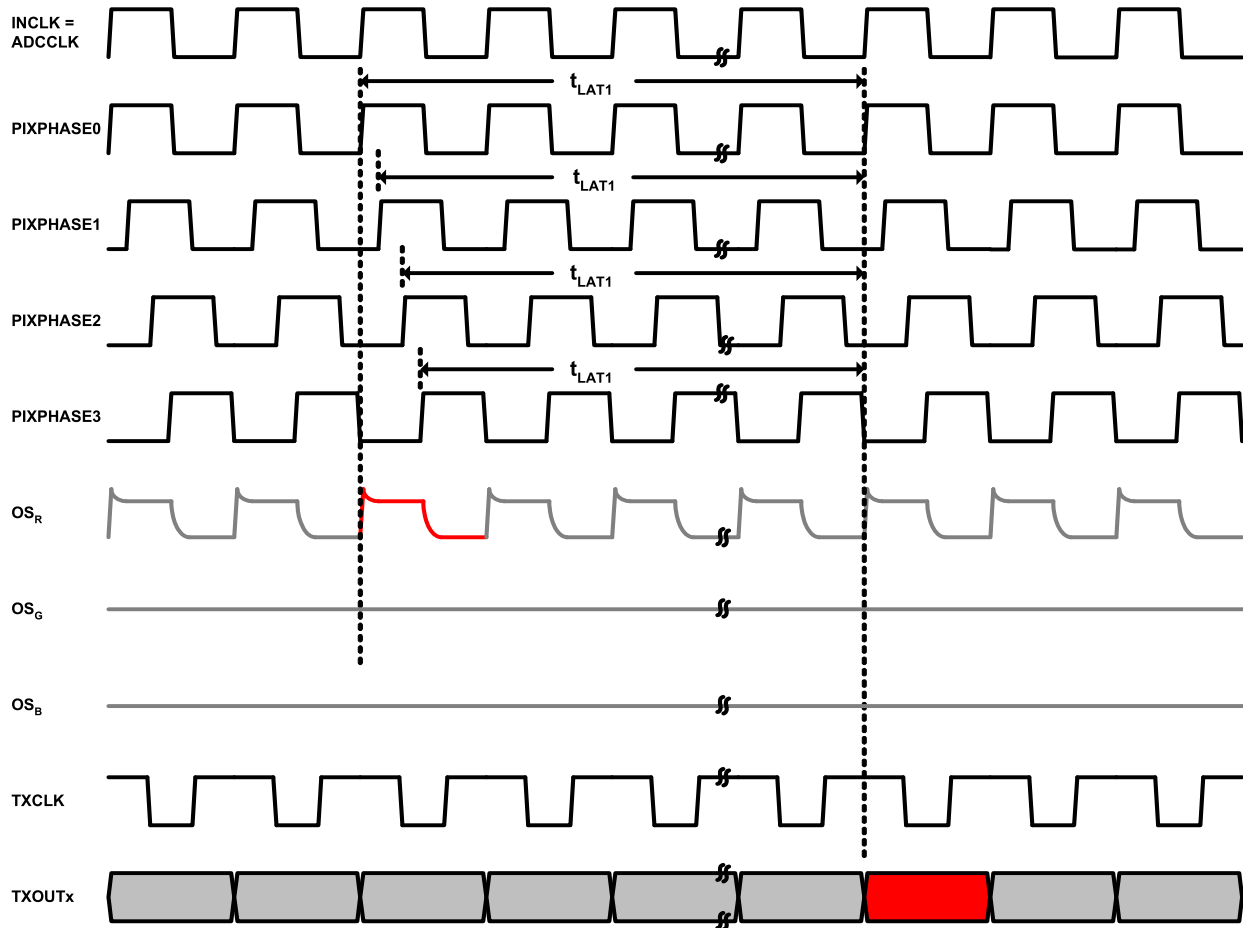

Data latency shown is for Mode 1 in relation to PIXPHASE0 with the processing channel configured to OS_R. If the incoming pixels are not aligned with PIXPHASE0, one of the remaining PIXPHASEs can be selected as the sampling phase without effecting the output data location.

Figure 56. Mode 1 LVDS Data Latency

7.4.22 Data Test Patterns

The data test patterns present different data to the input of the LVDS serializer block. There are two basic groups of test patterns:

- LVDS Output Pattern Modes - These patterns are applicable to all 21 bits of the LVDS interface.
- AFE Output Pattern Modes (Default) - These patterns are applicable to the 16 bit AFE data sent to the LVDS interface.
- All Test Pattern Modes are selected at Page 0, Register 6.

7.4.22.1 LVDS Output Pattern Modes

7.4.22.1.1 Worst Case Transitions (Alternating 0x2A/0x55 on Each LVDS Pair)

This test mode provides an LVDS output with the maximum possible transitions. This mode is useful for system EMI evaluations, and for ATE timing tests.

The effective data values are an alternating pattern between 21'b1010101010101010101 (0x155555) and 21'b010101010101010101010 (0x0AAAAA). This test pattern resets to 0x155555 at the selected event (BOL or BOS).

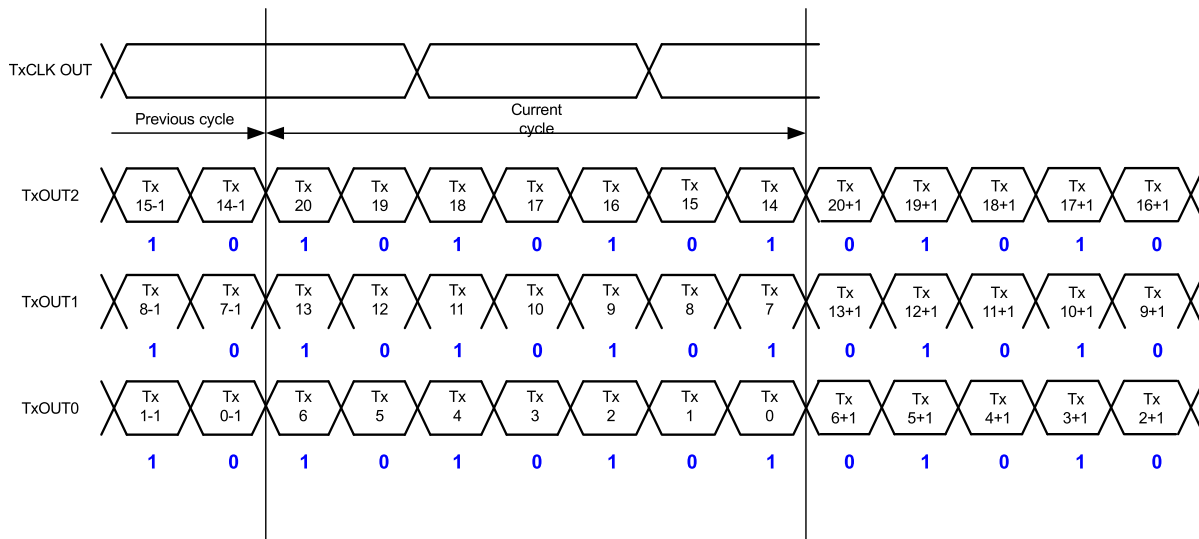

Figure 57. LVDS Output Pattern Modes

7.4.22.1.2 Fixed Output Data

This mode sends a fixed repeating data pattern to each of the indicated LVDS output pairs. This is useful for system debugging of the LVDS link and receiver circuitry. There are 4 different choices within this mode:

- 0x2A (0101010b) (All 3 data pairs)
- 0x55 (1010101b) (All 3 data pairs)
- (0000000b) (*All 3 data pairs + clock pair)
- 0x7F (1111111b) (*All 3 data pairs + clock pair)

*Since the 0x00 and 0x7F patterns also affect the clock pair, they cannot be used for deserializer and downstream testing. They are useful for DC measurements of the LVDS outputs.

7.4.22.2 AFE Output Pattern Modes

There are 3 different types of AFE Output Patterns:

- Normal ADC/AFE output (Default)
- Up-Counter Data
- Fixed AFE Patterns

7.4.22.2.1 Up-Counter Data

The counter will be reset to 0xFFFF during the BOS (Beginning Of Scan) SH Interval. When the AFE up-counter is selected, the ramp begins at the BOS, and increments by 1 at either the pixel rate or at the line rate (every BOL). This data can be useful as it can provide a grayscale image that increases in intensity down the “page”. Alternately, it can provide data that increments at the pixel rate. Either of these forms can be very useful in debugging the downstream data processing system.

7.4.22.2.2 Fixed AFE Pattern

The fixed AFE patterns allow the CB coding information to be sent normally, while specific data is used to replace the AFE output. This can be useful in debugging portions of the downstream data processing system.

- 0xFF00 (0x1111111100000000b) fixed data
- 0xAA55 (0x1010101001010101b) fixed data
- 0x0000 (0x0000000000000000b) fixed data
- 0xFFFF (0x1111111111111111b) fixed data
- 0x00FF (0x0000000011111111b) fixed data
- 0x55AA (0x0101010110101010b) fixed data

7.4.23 CMOS Output Format

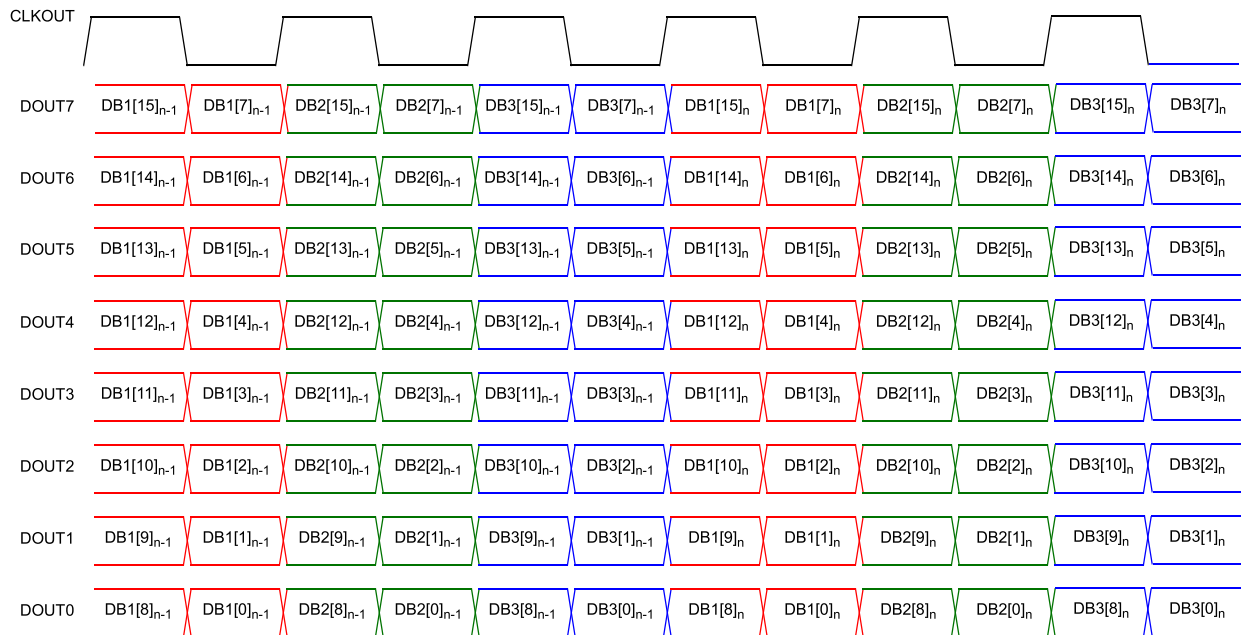
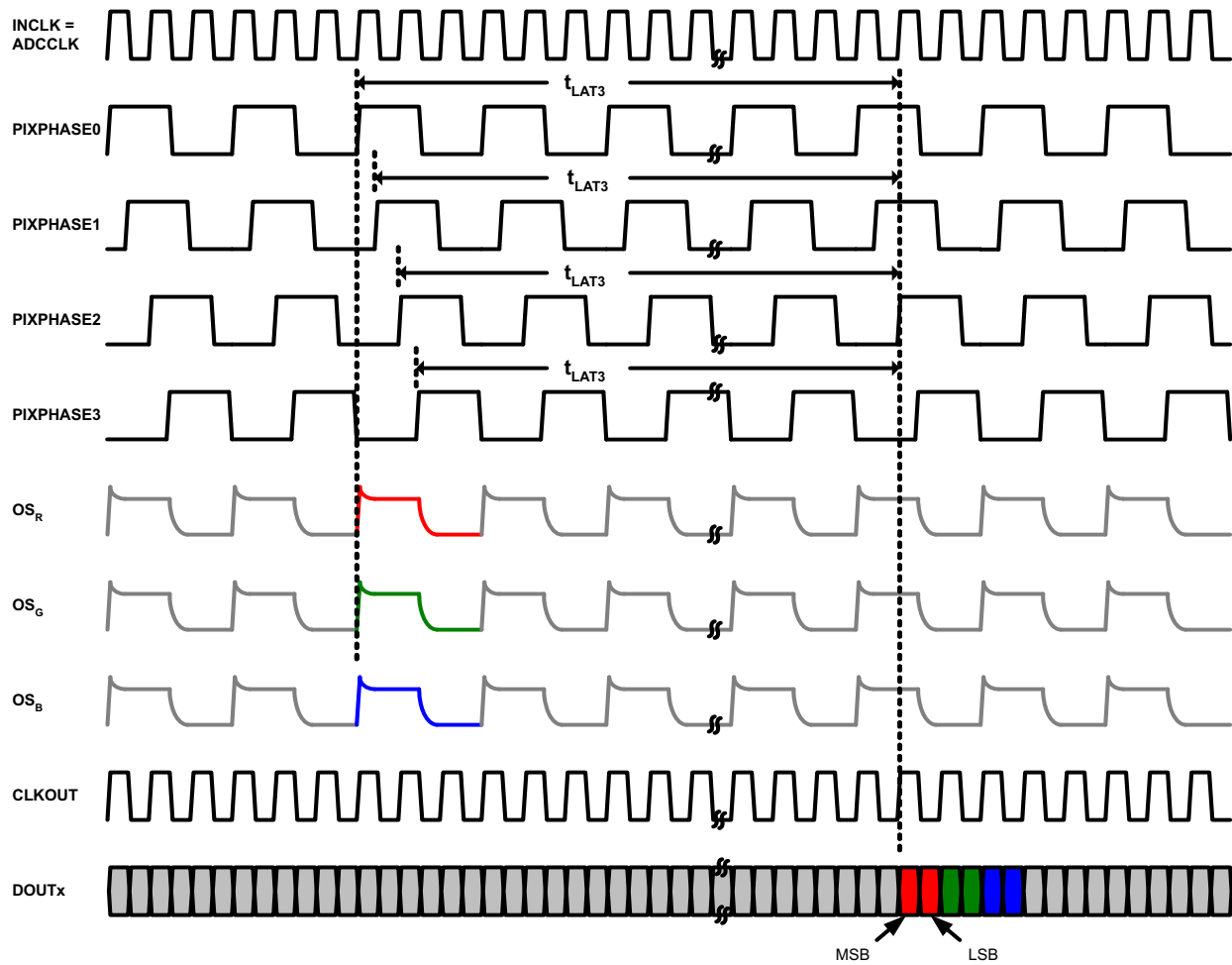

Figure 58. CMOS Data Output Format (Mode 3 Shown)

7.4.24 CMOS Output Data Latency Diagrams



Data latency shown is for Mode 3 in relation to PIXPHASE0 with the processing order set to OS_R → OS_G → OS_B. If the incoming pixels are not aligned with PIXPHASE0, one of the remaining PIXPHASEs can be selected as the sampling phase without effecting the output data location.

Figure 59. Mode 3 CMOS Output Latency

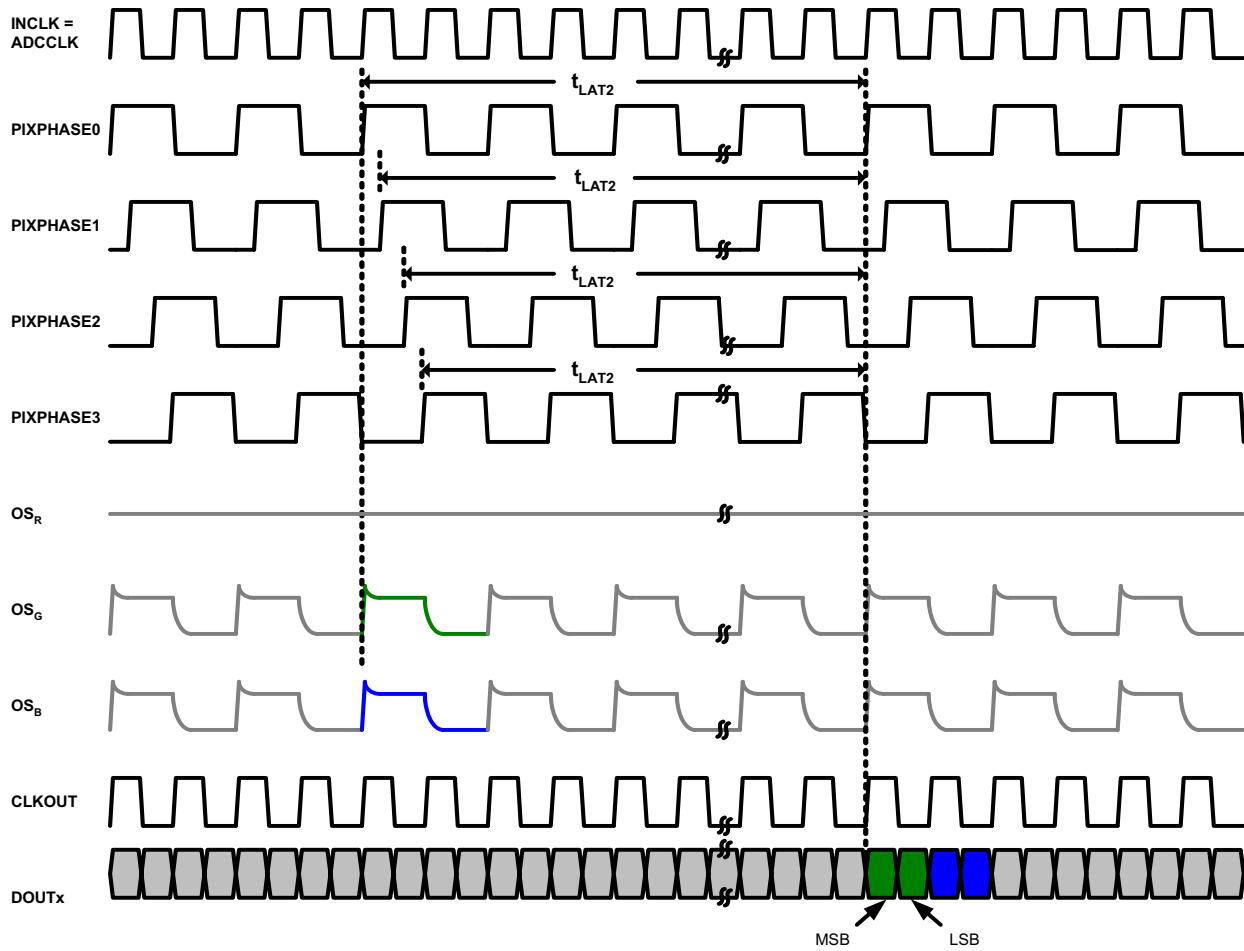

Data latency shown is for Mode 2 in relation to PIXPHASE0 with the processing order set to $OS_g \rightarrow OS_b$. If the incoming pixels are not aligned with PIXPHASE0, one of the remaining PIXPHASEs can be selected as the sampling phase without effecting the output data location.

Figure 60. Mode 2 CMOS Output Latency

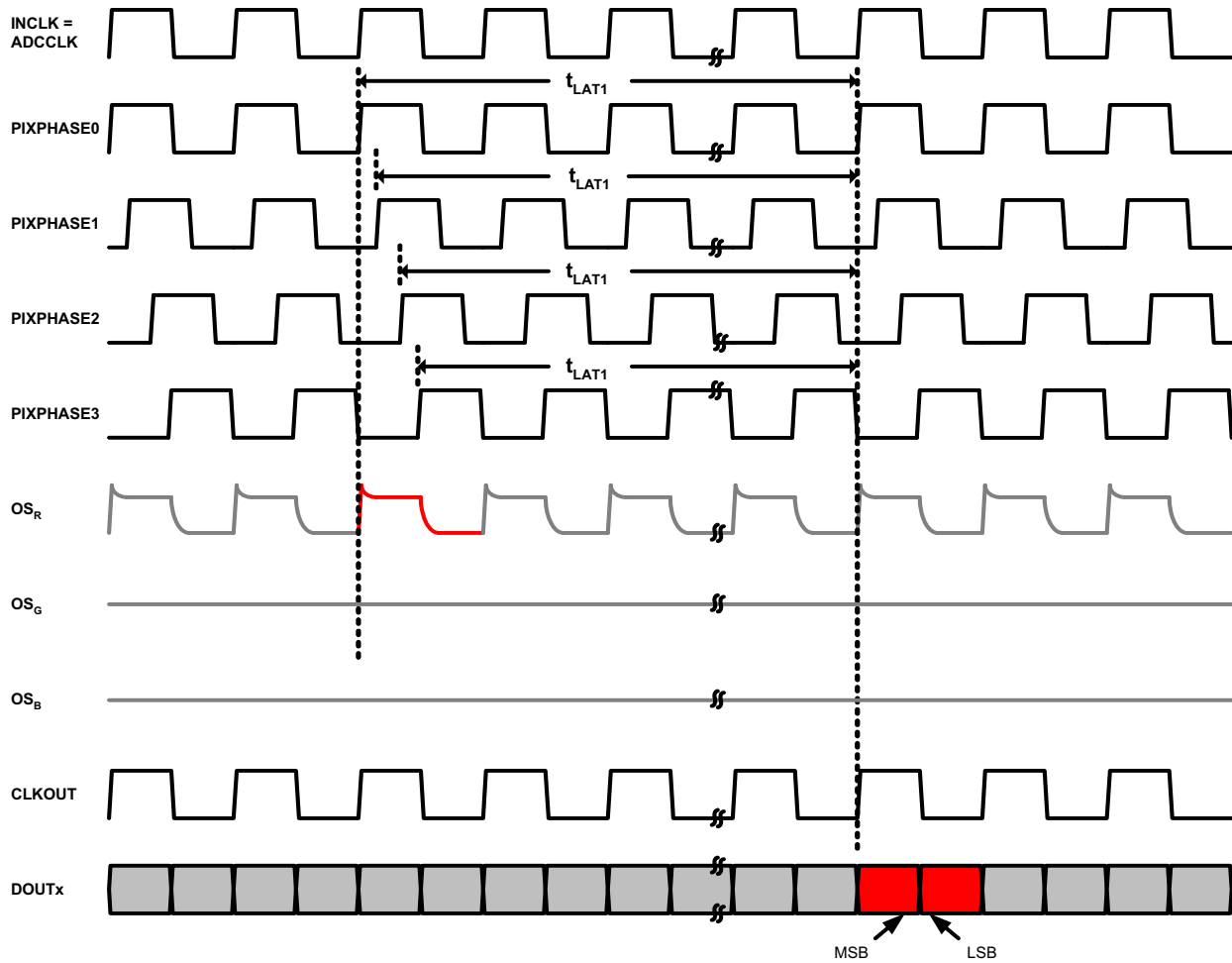

Data latency shown is for Mode 1 in relation to PIXPHASE0 with the processing channel configured to OS_r. If the incoming pixels are not aligned with PIXPHASE0, one of the remaining PIXPHASEs can be selected as the sampling phase without effecting the output data location.

Figure 61. Mode 1 CMOS Output Latency

7.4.25 Serial Interface

A serial interface is used to write and read the configuration registers. The interface is a four wire interface using SCLK, SEN, SDI and SDO connections. SDI and SDO can be connected together to support the same format and connectivity as previous LM98714 designs. The CE pin should be tied to GND to support LM98714 compatible communications. This will set the device address bits to 00.

Table 16. Serial Interface "CE" Pin Definition

CE LEVEL	ADDRESS
VD	01
Float	10
GND	00

The main input clock (INCLK) to the LM98725 can be active or stopped when accessing the Serial Interface. Care should be taken to avoid stopping or starting the INCLK during Serial Interface communication.

NOTE

After either starting or stopping INCLK, or after Software Reset (Register Page 0, Address 1, [4:3]), users should wait for 50 ms to allow the internal PLL and logic to stabilize before resuming Serial Interface communications.

7.4.25.1 Serial Interface Operating Modes

- **LM98714 Compatible Mode (Default)** - By default the serial interface is compatible with the LM98714 interface, allowing SDI and SDO to be connected and driving by a single pin on the host.
- **LM98725 4 Wire 16+ Clock Mode (Default)** - The 4 Wire 16+ Clock Mode is essentially the same as the LM98714 Compatible Mode, but using all 4 wires, with separate SDO and SDI signals between the Host and Slave. This requires additional wires, but removes the need for a bidirectional signal. A valid transaction is recognized after a minimum of 16 SCLK while $\overline{\text{SEN}}$ is low.
- **LM98725 25+ Clock Mode (Selected when Page 0, Register 0x01h, Bit 7=1)** - This mode forces the serial interface logic to only process a transaction with 25 or more SCLK while $\overline{\text{SEN}}$ is low. This mode can be used with either 3 or 4 wire connections.

In all of the above cases, the final 16 bits on SDI (before the rising edge of $\overline{\text{SEN}}$) are processed by the serial interface logic. Any earlier information on SDI is ignored.

7.4.25.2 Serial Interface in Absence of MCLK

- **Clockless (MCLK stopped) Mode (always enabled if MCLK stopped)** - When the input MCLK is stopped, Data Read operation is exactly the same as MCLK present mode. The Data Write operation no longer provides a free readback of the previously written data. See [Figure 64](#) and [Figure 66](#).

7.4.25.3 Writing to the Serial Registers

To write to the serial registers, the timing diagram shown in [Figure 62](#) must be met. First, SEN is toggled low. The *previously addressed device assumes control of the SDO pin during the first eight clocks of the command. During this period, data is clocked out of the device at the rising edge of SCLK. At the rising edge of ninth clock, the LM98725 releases control of the SDO pin. At the falling edge of the ninth clock period, the master should assume control of the SDI pin and begin issuing the new command. SDI is clocked into the LM98725 at the rising edge of SCLK. The remaining bits are composed of the "write" command bit (a zero), two device address bits (00, 01 or 10 for the LM98725), five bit register address to be written, and the eight bit register value to be written. When SEN toggles high, the register is written to, and the LM98725 now functions with this new data.

*The previously addressed device could be another device on a shared serial interface or this device. If the previous command was to this device, and was a read, then the SDO pin will be driven during the first eight clocks. If the previous command was to this device and was a write, then the SDO pin will only be driven if the serial interface is in "MCLK active" mode.

7.4.25.4 Reading the Serial Registers

To read to the serial registers, the timing diagram shown in [Figure 63](#) must be met. First, SEN is toggled low. The LM98725 assumes control of the SDO pin during the first eight clocks of the command. During this period, data is clocked out of the device at the rising edge of SCLK. The eight bit value clocked out is the contents of the previously addressed register, regardless if the previous command was a read or a write. At the rising edge of ninth clock, the LM98725 releases control of the SDO pin. At the falling edge of the ninth clock period, the master should assume control of the SDI pin and begin issuing the new command. SDI is clocked into the LM98725 at the rising edge of SCLK. The remaining bits are composed of the “read” command bit (a one), two device address bits (zeros for the LM98725), five bit register address to be read, and the eight bit “don’t care” bits. When SEN toggles high, the register is not written to, but its contents are staged to be outputted at the beginning of the next command.

Examples of Serial Writes and Reads in the various modes are shown in [Figure 62](#) through [Figure 67](#).

7.4.25.5 LM98714 Compatible 3 Wire Serial Signaling

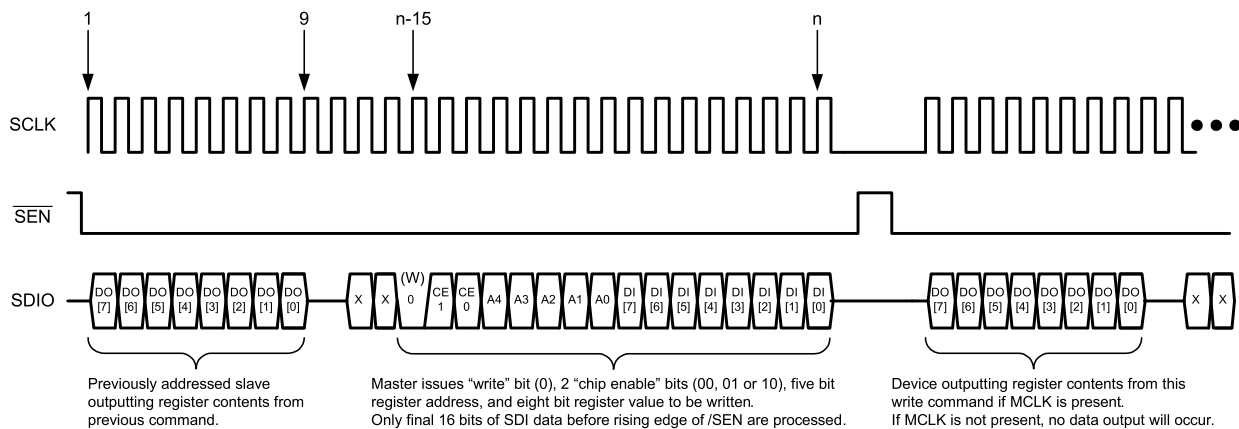

Figure 62. Serial Write - LM98714 Compatible Connection

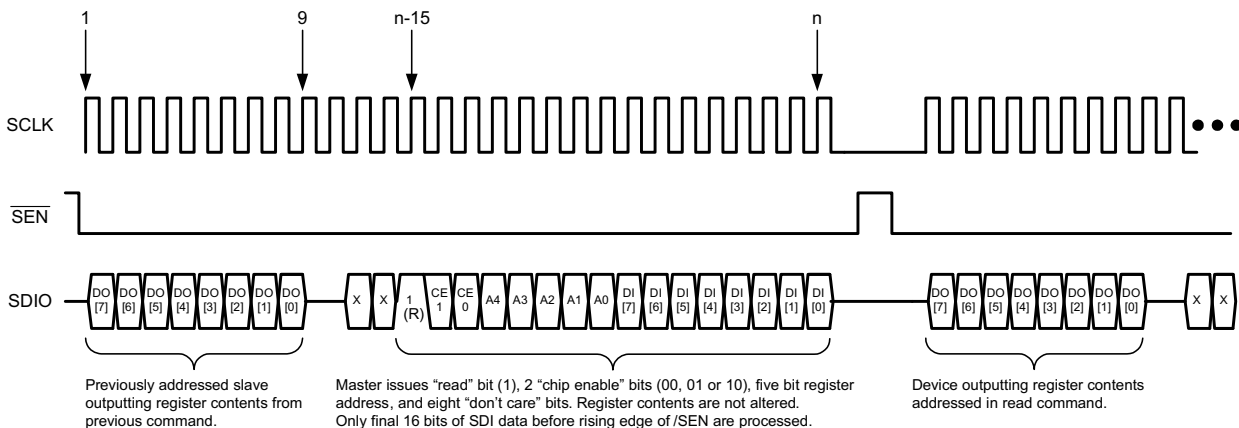

Figure 63. Serial Read - LM98714 Compatible Connection

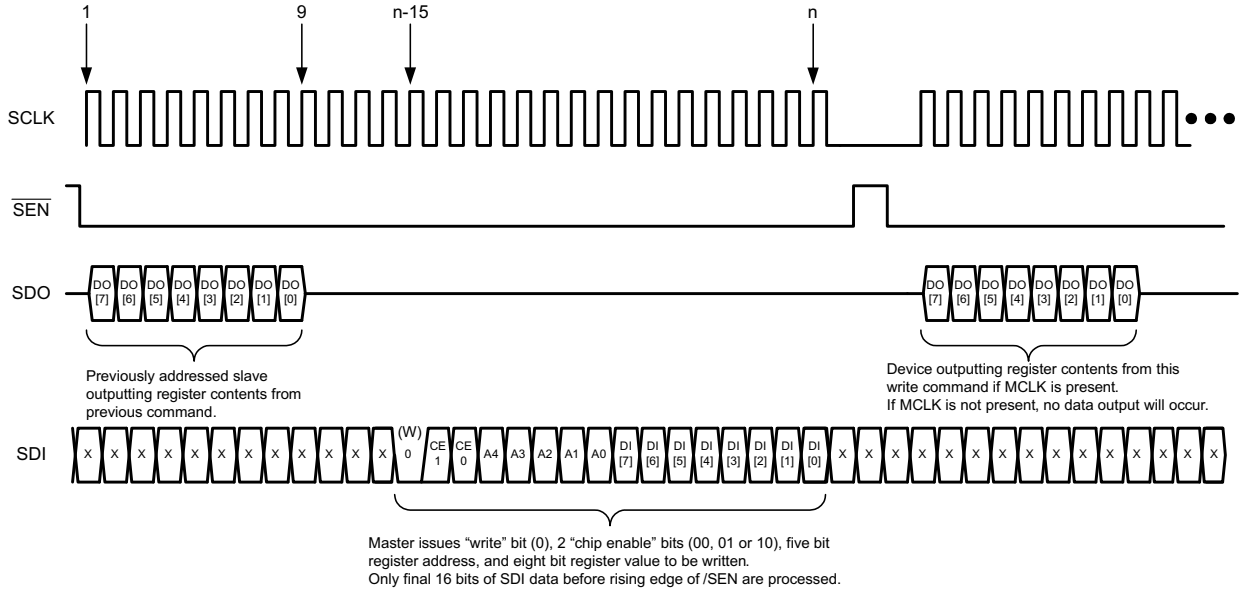

Figure 64. Serial Write - 4 Wire Connection - 25+ Clock Mode

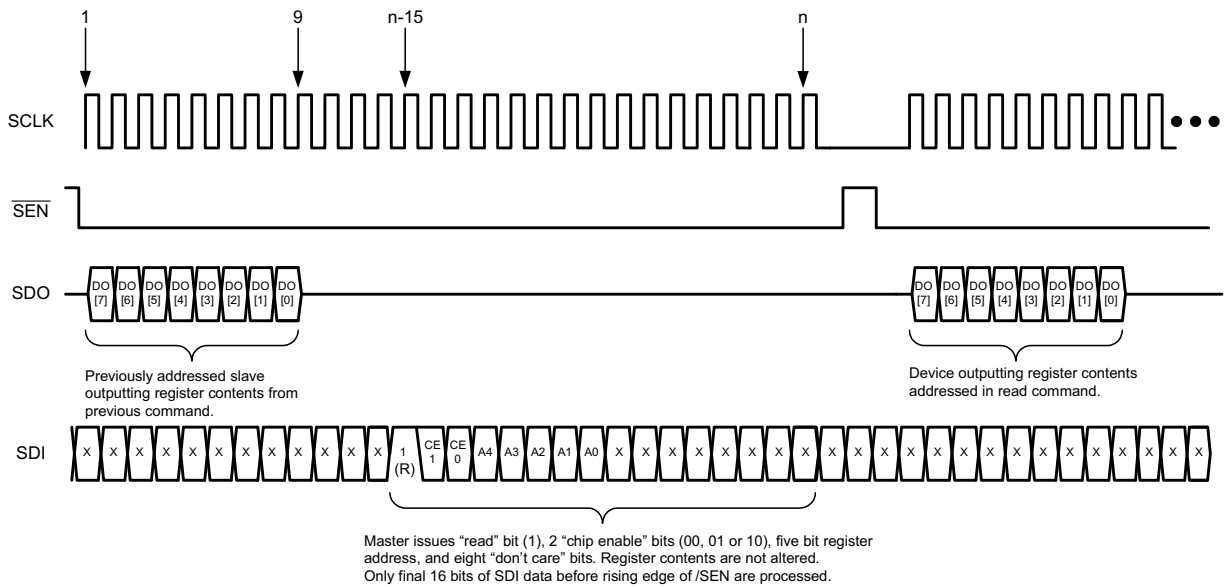

Figure 65. Serial Read - 4 Wire Connection - 25+ Clock Mode

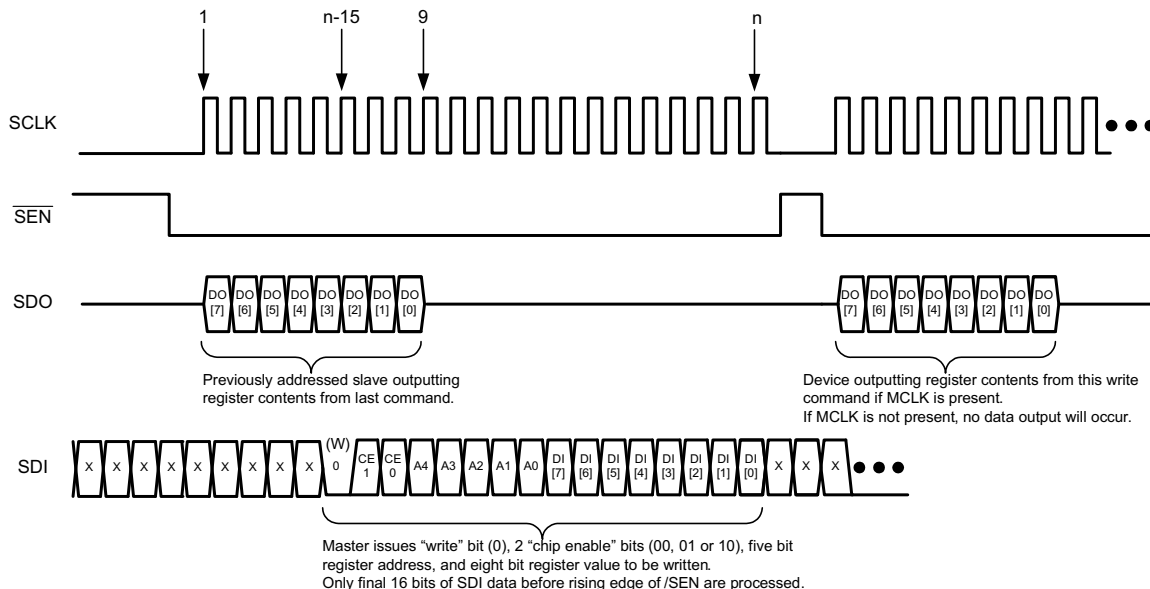

Figure 66. Serial Write - 4 Wire Connection - 16+ Clock Mode

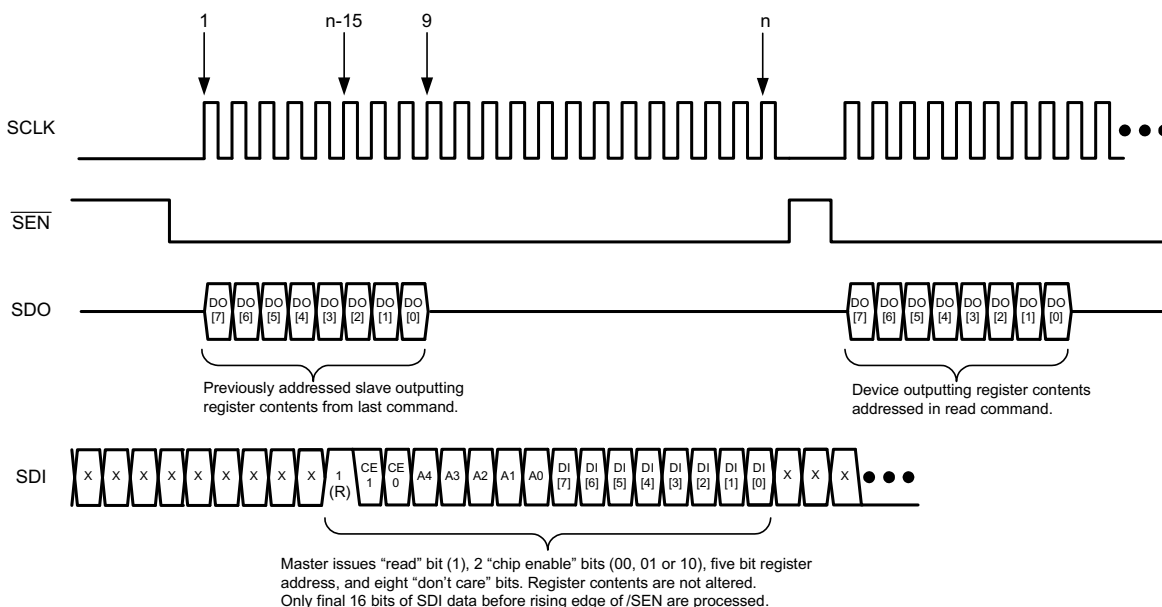

Figure 67. Serial Read - 4 Wire Connection - 16+ Clock Mode

7.5 Register Maps

7.5.1 Configuration Registers

The LM98725 operation is very flexible to support a wide variety of sensors and system designs. This flexibility is controlled through configuration registers which are first summarized, then described in full in the following tables. Because the serial interface only allows 5 address bits, a register paging system is used to support the larger number of required registers.

The page register is present at the highest address (1Fh or 11111b) of the currently selected page. The power on default setting of the page register is 00. Writing other values to this register allows the other pages to be accessed.

Once all registers are written, the Register Lock Control bit (Page 0, Register 0, Bit 0) is set to 1 to start the state machines and initiate the converting of pixels. If Slave mode is selected, SH_R pulses must also be input to trigger this process.

NOTE

When Register Lock Control = 1, many registers are locked to prevent state machines from becoming corrupted, while others are accessible to allow control of necessary functions. The registers and bits that are still writable are indicated in **Boldface** print in the Bits and Register Description columns of the Register Definition Details table.

Operational Setup Sequence:

Ensure Lock Bit (Page 0, Register 0, Bit 0) = 0 for following setting writes

Apply either no INCLK or a stable INCLK to ensure accurate serial communications

Page 0

- Set AFE mode (# of input channels)
- Set output data format
- Enable data outputs
- Set AFE biasing
- Set AFE Clamp and Sample timing
- Setup Slave or Master Mode

Page 1

- Set Gain Mode (Single or Dual)
- Set CDS/SH Gain
- Set PGA
- Set DAC settings

Page 2

- Set Input Clamping Settings
- Set Black Pixel Start and # Black Pixels Averaged
- Set Active White Pixels Start and End
- Set Line Length (Master Mode Only)
- Set # Pixel Multiplier, SH Line Sequence # and SH State Length Multiplier
- Set PHI, RS, CP On and Off delay settings
- Set Spread Spectrum control settings

Register Maps (continued)**Page 3**

Set SH Slate Length Settings

Page 4

Set SH Interval State Settings for PHI, RS, CP

Page 5

Set SH Interval State Settings for SH1 to SH5

Page 6

Set PHI, RS, CP pattern bit fields and rate (normal or 1/2 rate)

Page 7

- Set SHx On, Off settings if needed
- Set CLK invert settings for multi-line sequences if needed

Page 8

- Set CLK output activity, polarity, enable
- Set LVDS output format
- Set CB coding
- Set PHI, RS, CP, SH unlock output state

Begin Scanning:

- Ensure stable INCLK applied and PLL is locked (read back Page 0, Register 0, Bit 7)
- Set Register Lock Control bit = 1
- In Master Mode, conversions will begin after the Lock Bit is set. In Slave Mode, SH_R pulses can begin after the Lock Bit is set. SH Intervals will be generated in response to the SH_R input pulses.
- Registers and Bits marked in Boldface print may be adjusted while scanning is in progress. More major changes (that is, color mode, CCDTG details) should be done by writing a 0 to the Register Lock Control Bit to pause scanning.

Register Maps (continued)
7.5.1.1 Register Summary Table
Table 17. Register Summary Table

Page (dec)	Addr (dec)	Addr (hex)	Default (binary)	Register Title
PAGE 0				
0	0	0	0010 0000	Main Configuration 0
0	1	1	0100 0000	Main Configuration 1
0	2	2	1100 0000	Main Configuration 2
0	3	3	1000 0010	Main Configuration 3
0	4	4	0011 0000	Main Configuration 4
0	5	5	0000 0000	Main Configuration 5
0	6	6	0000 0000	Configuration 6
0	7	7	0000 0000	Configuration 7
0	8	8	0000 0000	OSR CLAMP Start Edge
0	9	9	0001 0000	OSR CLAMP Stop Edge
0	10	A	0000 0000	OSG CLAMP Start Edge
0	11	B	0001 0000	OSG CLAMP Stop Edge
0	12	C	0000 0000	OSB CLAMP Start Edge
0	13	D	0001 0000	OSB CLAMP Stop Edge
0	14	E	0001 0110	OSR SAMPLE Start Edge
0	15	F	0010 0110	OSR SAMPLE Stop Edge
0	16	10	0001 0110	OSG SAMPLE Start Edge
0	17	11	0010 0110	OSG SAMPLE Stop Edge
0	18	12	0001 0110	OSB SAMPLE Start Edge
0	19	13	0010 0110	OSB SAMPLE Stop Edge
0	20	14	0000 0000	Sample & Clamp Monitor 0
0	21	15	0000 0000	Sample & Clamp Monitor 1
0	22 to 29	16 to 1D		Reserved
0	30	1E	XX00 0011	Revision
0	31	1F	0000 0000	Page Register

Register Maps (continued)
Table 17. Register Summary Table (continued)

Page (dec)	Addr (dec)	Addr (hex)	Default (binary)	Register Title
PAGE 1				
1	0	0	0000 0000	Gain Mode
1	1	1	0110 0001	Red PGA
1	2	2	0110 0001	Green PGA
1	3	3	0110 0001	Blue PGA
1	4	4	1000 0000	Red Even DAC MSB
1	5	5	0000 0000	Red Even DAC LSB
1	6	6	1000 0000	Green Even DAC MSB
1	7	7	0000 0000	Green Even DAC LSB
1	8	8	1000 0000	Blue Even DAC MSB
1	9	9	0000 0000	Blue Even DAC LSB
1	10	A	1000 0000	Red Odd DAC MSB
1	11	B	0000 0000	Red Odd DAC LSB
1	12	C	1000 0000	Green Odd DAC MSB
1	13	D	0000 0000	Green Odd DAC LSB
1	14	E	1000 0000	Blue Odd DAC MSB
1	15	F	0000 0000	Blue Odd DAC LSB
1	16	10	0100 0000	Red Even Digital Offset
1	17	11	0100 0000	Green Even Digital Offset
1	18	12	0100 0000	Blue Even Digital Offset
1	19	13	0100 0000	Red Odd Digital Offset
1	20	14	0100 0000	Green Odd Digital Offset
1	21	15	0100 0000	Blue Odd Digital Offset
1	22	16	0110 0001	Red High Gain PGA
1	23	17	0110 0001	Green High Gain PGA
1	24	18	0110 0001	Blue High Gain PGA
1	28	1C	0100 0000	Red Channel Bimodal
1	29	1D	0100 0000	Green Channel Bimodal
1	30	1E	0100 0000	Blue Channel Bimodal
1	31	1F	0000 0000	Page Register

Register Maps (continued)
Table 17. Register Summary Table (continued)

Page (dec)	Addr (dec)	Addr (hex)	Default (binary)	Register Title
PAGE 2				
2	0	0	0000 0000	Calibration Mode
2	1	1	0000 0000	Calibration # Lines
2	2	2	0001 0100	Black Cal Config
2	3	3	0100 0000	Black Target
2	4	4	0100 0011	White Cal Config
2	5	5	1000 0000	White Target
2	6	6	0000 0100	AutoCLPIN Start
2	7	7	0000 1100	AutoCLPIN End
2	8	8	0001 0000	Black Loop Start
2	9	9	0000 0000	Active/White Pixels Start - MSB
2	10	A	0001 0100	Active/White Pixels Start - LSB
2	11	B	0001 0000	Active/White Pixels End - MSB
2	12	C	0000 0000	Active/White Pixels End - LSB
2	13	D	0001 0000	Line Length MSB
2	14	E	0100 0000	Line Length LSB
2	15	F	0000 0000	Line Length Multiplier
2	16	10	0000 0000	Line Mode
2	17	11	0000 0000	SH State Length Multiplier
2	18	12	0000 0000	PHIA/B/C Delays
2	19	13	0000 0000	RS/CP Delays
2	20 to 23	14 to 17		Reserved
2	24	18	1111 1000	PLL Control 1
2	25	19	0001 1000	PLL Control 2
2	26	1A	0000 0000	SSCG Control 1
2	27	1B	0000 0010	SSCG Control 2
2	28	1C	0000 0000	Clock Mult M
2	29	1D	0000 0000	Clock Mult N
2	30	1E	0000 0000	SSCG Control 3
2	31	1F		Page Register

Register Maps (continued)
Table 17. Register Summary Table (continued)

Page (dec)	Addr (dec)	Addr (hex)	Default (binary)	Register Title
PAGE 3				
3	0	0	0000 0000	SH State 0 Length
3	1	1	0000 0000	SH State 1 Length
3	2	2	0000 0000	SH State 2 Length
3	3	3	0000 0000	SH State 3 Length
3	4	4	0000 0000	SH State 4 Length
3	5	5	0000 0000	SH State 5 Length
3	6	6	0000 0000	SH State 6 Length
3	7	7	0000 0000	SH State 7 Length
3	8	8	0000 0000	SH State 8 Length
3	9	9	0000 0000	SH State 9 Length
3	10	A	0000 0000	SH State 10 Length
3	11	B	0000 0000	SH State 11 Length
3	12	C	0000 0000	SH State 12 Length
3	13	D	0000 0000	SH State 13 Length
3	14	E	0000 0000	SH State 14 Length
3	15	F	0000 0000	SH State 15 Length
3	16	10	0000 0000	SH State 16 Length
3	17	11	0000 0000	SH State 17 Length
3	18	12	0000 0000	SH State 18 Length
3	19	13	0000 0000	SH State 19 Length
3	20	14	0000 0000	SH State 20 Length
3	21	15	0000 0000	SH State 21 Length
3	22	16	0000 0000	SH State 22 Length
3	23	17	0000 0000	SH State 23 Length
3	24	18	0000 0000	SH State 24 Length
3	25	19	0000 0000	SH State 25 Length
3	26	1A	0000 0000	SH State 26 Length
3	27	1B	0000 0000	SH State 27 Length
3	28	1C	0000 0000	SH State 28 Length
3	29	1D	0000 0000	SH State 29 Length
3	30	1E	0000 0000	SH State 30 Length
3	31	1F		Page Register

Register Maps (continued)
Table 17. Register Summary Table (continued)

Page (dec)	Addr (dec)	Addr (hex)	Default (binary)	Register Title
PAGE 4				
4	0	0	0000 0000	SH State 0 PHI, RS, CP
4	1	1	0000 0000	SH State 1 PHI, RS, CP
4	2	2	0000 0000	SH State 2 PHI, RS, CP
4	3	3	0000 0000	SH State 3 PHI, RS, CP
4	4	4	0000 0000	SH State 4 PHI, RS, CP
4	5	5	0000 0000	SH State 5 PHI, RS, CP
4	6	6	0000 0000	SH State 6 PHI, RS, CP
4	7	7	0000 0000	SH State 7 PHI, RS, CP
4	8	8	0000 0000	SH State 8 PHI, RS, CP
4	9	9	0000 0000	SH State 9 PHI, RS, CP
4	10	A	0000 0000	SH State 10 PHI, RS, CP
4	11	B	0000 0000	SH State 11 PHI, RS, CP
4	12	C	0000 0000	SH State 12 PHI, RS, CP
4	13	D	0000 0000	SH State 13 PHI, RS, CP
4	14	E	0000 0000	SH State 14 PHI, RS, CP
4	15	F	0000 0000	SH State 15 PHI, RS, CP
4	16	10	0000 0000	SH State 16 PHI, RS, CP
4	17	11	0000 0000	SH State 17 PHI, RS, CP
4	18	12	0000 0000	SH State 18 PHI, RS, CP
4	19	13	0000 0000	SH State 19 PHI, RS, CP
4	20	14	0000 0000	SH State 20 PHI, RS, CP
4	21	15	0000 0000	SH State 21 PHI, RS, CP
4	22	16	0000 0000	SH State 22 PHI, RS, CP
4	23	17	0000 0000	SH State 23 PHI, RS, CP
4	24	18	0000 0000	SH State 24 PHI, RS, CP
4	25	19	0000 0000	SH State 25 PHI, RS, CP
4	26	1A	0000 0000	SH State 26 PHI, RS, CP
4	27	1B	0000 0000	SH State 27 PHI, RS, CP
4	28	1C	0000 0000	SH State 28 PHI, RS, CP
4	29	1D	0000 0000	SH State 29 PHI, RS, CP
4	30	1E	0000 0000	SH State 30 PHI, RS, CP
4	31	1F		Page Register

Register Maps (continued)
Table 17. Register Summary Table (continued)

Page (dec)	Addr (dec)	Addr (hex)	Default (binary)	Register Title
PAGE 5				
5	0	0	0000 0000	SH State 0 SH1-SH5
5	1	1	0000 0000	SH State 1 SH1-SH5
5	2	2	0000 0000	SH State 2 SH1-SH5
5	3	3	0000 0000	SH State 3 SH1-SH5
5	4	4	0000 0000	SH State 4 SH1-SH5
5	5	5	0000 0000	SH State 5 SH1-SH5
5	6	6	0000 0000	SH State 6 SH1-SH5
5	7	7	0000 0000	SH State 7 SH1-SH5
5	8	8	0000 0000	SH State 8 SH1-SH5
5	9	9	0000 0000	SH State 9 SH1-SH5
5	10	A	0000 0000	SH State 10 SH1-SH5
5	11	B	0000 0000	SH State 11 SH1-SH5
5	12	C	0000 0000	SH State 12 SH1-SH5
5	13	D	0000 0000	SH State 13 SH1-SH5
5	14	E	0000 0000	SH State 14 SH1-SH5
5	15	F	0000 0000	SH State 15 SH1-SH5
5	16	10	0000 0000	SH State 16 SH1-SH5
5	17	11	0000 0000	SH State 17 SH1-SH5
5	18	12	0000 0000	SH State 18 SH1-SH5
5	19	13	0000 0000	SH State 19 SH1-SH5
5	20	14	0000 0000	SH State 20 SH1-SH5
5	21	15	0000 0000	SH State 21 SH1-SH5
5	22	16	0000 0000	SH State 22 SH1-SH5
5	23	17	0000 0000	SH State 23 SH1-SH5
5	24	18	0000 0000	SH State 24 SH1-SH5
5	25	19	0000 0000	SH State 25 SH1-SH5
5	26	1A	0000 0000	SH State 26 SH1-SH5
5	27	1B	0000 0000	SH State 27 SH1-SH5
5	28	1C	0000 0000	SH State 28 SH1-SH5
5	29	1D	0000 0000	SH State 29 SH1-SH5
5	30	1E	0000 0000	SH State 30 SH1-SH5
5	31	1F		Page Register

Register Maps (continued)
Table 17. Register Summary Table (continued)

Page (dec)	Addr (dec)	Addr (hex)	Default (binary)	Register Title
PAGE 6				
6	0	0	0000 0000	PHIA0
6	1	1	0000 0000	PHIA1
6	2	2	0000 0000	PHIA2
6	3	3	0000 0000	PHIA3
6	4	4	0000 0000	PHIA4
6	5	5	0000 0000	PHIA5
6	6	6	0000 0000	PHIB0
6	7	7	0000 0000	PHIB1
6	8	8	0000 0000	PHIB2
6	9	9	0000 0000	PHIB3
6	10	A	0000 0000	PHIB4
6	11	B	0000 0000	PHIB5
6	12	C	0000 0000	PHIC0
6	13	D	0000 0000	PHIC1
6	14	E	0000 0000	PHIC2
6	15	F	0000 0000	PHIC3
6	16	10	0000 0000	PHIC4
6	17	11	0000 0000	PHIC5
6	18	12	0000 0000	RS0
6	19	13	0000 0000	RS1
6	20	14	0000 0000	RS2
6	21	15	0000 0000	RS3
6	22	16	0000 0000	RS4
6	23	17	0000 0000	RS5
6	24	18	0000 0000	CP0
6	25	19	0000 0000	CP1
6	26	1A	0000 0000	CP2
6	27	1B	0000 0000	CP3
6	28	1C	0000 0000	CP4
6	29	1D	0000 0000	CP5
6	30	1E	0000 0000	HSPiX Rate Select
6	31	1F		Page Register

Register Maps (continued)
Table 17. Register Summary Table (continued)

Page (dec)	Addr (dec)	Addr (hex)	Default (binary)	Register Title
PAGE 7				
7	0	0	0000 0000	SH1 PIXEL ON MSB
7	1	1	0000 0000	SH1 PIXEL ON LSB
7	2	2	0000 0000	SH1 PIXEL OFF MSB
7	3	3	0000 0000	SH1 PIXEL OFF LSB
7	4	4	0000 0000	SH2 PIXEL ON MSB
7	5	5	0000 0000	SH2 PIXEL ON LSB
7	6	6	0000 0000	SH2 PIXEL OFF MSB
7	7	7	0000 0000	SH2 PIXEL OFF LSB
7	8	8	0000 0000	SH3 PIXEL ON MSB
7	9	9	0000 0000	SH3 PIXEL ON LSB
7	10	A	0000 0000	SH3 PIXEL OFF MSB
7	11	B	0000 0000	SH3 PIXEL OFF LSB
7	12	C	0000 0000	SH4 PIXEL ON MSB
7	13	D	0000 0000	SH4 PIXEL ON LSB
7	14	E	0000 0000	SH4 PIXEL OFF MSB
7	15	F	0000 0000	SH4 PIXEL OFF LSB
7	16	10	0000 0000	SH5 PIXEL ON MSB
7	17	11	0000 0000	SH5 PIXEL ON LSB
7	18	12	0000 0000	SH5 PIXEL OFF MSB
7	19	13	0000 0000	SH5 PIXEL OFF LSB
7	20	14	0000 0000	PHIA Polarity Override
7	21	15	0000 0000	PHIB Polarity Override
7	22	16	0000 0000	PHIC Polarity Override
7	23	17	0000 0000	RS Polarity Override
7	24	18	0000 0000	CP Polarity Override
7	25	19	0000 0000	SH1 Polarity Override
7	26	1A	0000 0000	SH2 Polarity Override
7	27	1B	0000 0000	SH3 Polarity Override
7	28	1C	0000 0000	SH4 Polarity Override
7	29	1D	0000 0000	SH5 Polarity Override
7	30	1E	0000 0000	Reserved
7	31	1F		Page Register

Register Maps (continued)
Table 17. Register Summary Table (continued)

Page (dec)	Addr (dec)	Addr (hex)	Default (binary)	Register Title
PAGE 8				
8	0	0	0000 0000	PHIA1, PHIA2 Polarity / State
8	1	1	0000 0000	PHIB1, PHIB2 Polarity / State
8	2	2	0000 0000	PHIC1, PHIC2 Polarity / State
8	3	3	0000 0000	RS, CP Polarity / State
8	4	4	0000 0000	SH1, SH2 Polarity / State
8	5	5	0000 0000	SH3, SH4 Polarity / State
8	6	6	0000 0000	SH5 Polarity / State
8	7	7	0000 0000	Reserved
8	8	8	0010 0000	LVDS Configuration
8	9	9	0000 0000	CB1/CB0 CB Mapping
8	10	A	0000 0000	CB3/CB2 CB Mapping
8	11	B	0000 0000	D2/CB4 CB Mapping
8	12	C	0000 0000	D4/D3 CB Mapping
8	13	D	0000 0000	D5 CB Mapping
8	14	E	0000 0000	Unlock State Output Values PHIA, PHIB, PHIC, RS, CP
8	15	F	0000 0000	Unlock State Output Values SH1, SH2, SH3, SH4, SH5
8	16 to 17	10 to 11	0000 0000	Reserved
8	18	12	0000 0000	Scrambler Inhibit 0 (LVDS[6:0])
8	19	13	0000 0000	Scrambler Inhibit 1 (LVDS[13:7])
8	20	14	0000 0000	Scrambler Inhibit 2 (LVDS[20:14])
8	16 to 30	15 to 1E	0000 0000	Reserved
8	31	1F		Page Register

Table 18 describes all available registers in the LM98725 register bank, and their functions .

NOTE: Registers and/or Bits Marked in Boldface are Writeable when Register 0, Bit 0 = 1. All others are "Locked".

Table 18. Register Definitions

PAGE (DEC)	ADDR (DEC)	ADDR (HEX)	DEFAULT (BINARY)	BITS	REGISTER TITLE	REGISTER DESCRIPTION
PAGE 0						
0	0	0	0010 0000	[7]		PLL Locked (READ ONLY) Status Bit 0 PLL is not locked 1 PLL is locked
				[6]		Not Used
				[5]		SH_R Capture Clock Select 0 Use internal CLK from XTAL source. 1 Use external INCLK source.
				[4]		SH_R Capture Edge Select 0 Use rising edge of selected Clock source. 1 Use falling edge of selected Clock source.
				[3]	Main	Not Used
				[2]	Configuration 0	XTALEN 0 Use autodetecting CMOS/LVDS clock receiver 1 Enable crystal driver. INCLK+ is output, INCLK- is input.
				[1]		Master Mode Select Bit 0 Slave/SH_R 1 Master/Line Length
				[0]		Register Lock Control 0 Registers are unlocked (i.e. writeable) and CCDTG state machines are stopped 1 Registers are locked (default) and CCDTG state machines are operating

Table 18. Register Definitions (continued)

PAGE (DEC)	ADDR (DEC)	ADDR (HEX)	DEFAULT (BINARY)	BITS	REGISTER TITLE	REGISTER DESCRIPTION
0	1	1	0100 0000	[7]		Serial Interface Mode Select 0 16+ Clock Mode [Default] 1 25+ Clock Mode
				[6]		Enable PLL Range Autocalibration 0 PLL Range Autocal OFF 1 PLL Range Autocalibrates (Default)
				[5]		Calibrate Gain/Offset (self clearing) 0 Calibration is off 1 Calibration is active
				[4]	Main Configuration 1	Software Reset - FSM Set to 1 to reset all state machines. Self clearing.
				[3]		Software Reset - FSM + Registers Set to 1 to reset all state machines and registers. Self clearing.
				[2]		Power Down CDS/SH Amplifier
				[1]		Reference Buffer Power Down
				[0]		Master Power Down 0 Master Power Down Disable 1 Master Power Down Enable

Table 18. Register Definitions (continued)

PAGE (DEC)	ADDR (DEC)	ADDR (HEX)	DEFAULT (BINARY)	BITS	REGISTER TITLE	REGISTER DESCRIPTION
0	2	2	1100 0010	[7:6]	Main Configuration 2	Mode Select Bits 11 Mode 3 (Default) (3 Channel Mode) 10 Mode 2 (2 Channel Mode) 01 Mode 1 (1 Channel Mode) 00 Not Used
				[5:4]		Color Select Bits. Used to determine the inputs sampled during a scan. 11 Reserved 10 Mode 2 = OSR & OSB Mode 1 = OSB 01 Mode 2 = OSG & OSB Mode 1 = OSG 00 Mode 2 = OSR & OSG Mode 1 = OSR
				[3]		Color Order. Configures the sequence of the pixel processing 0 Forward (default) 1 Reverse
				[2]		PIXCLK/ADCCLK Configuration. Selects appropriate multiplier for given input clock frequency Mode 3: ADC Frequency = 3x Pixel Frequency Mode 2: ADC Frequency = 2x Pixel Frequency Mode 1: ADC Frequency = 1x Pixel Frequency 0 User supplies ADC rate clock, LM98725 performs no multiplication. 1 User supplies Pixel rate clock, LM98725 performs clock multiplication.
				[1]		Sampling Mode Select 0 Sample and Hold Mode 1 Correlated Double Sampling Mode (Default)
				[0]		Even/Odd CCD Sensor Enable Dedicated Even and Odd DACs and Digital Offsets would be applied to every other pixels.

Table 18. Register Definitions (continued)

PAGE (DEC)	ADDR (DEC)	ADDR (HEX)	DEFAULT (BINARY)	BITS	REGISTER TITLE	REGISTER DESCRIPTION
0	3	3	1000 0010	[7]	Main Configuration 3	Source Follower Enable. 0 Disable 1 Enable (Default)
				[6]		Input Bias Enable. Enables the Input Bias Resistor ladder. 0 Disable (Default) 1 Enable
				[5]		Bit CLP mode enable (black clamping done in reference portion of every pixel of line) 0 Disabled (Default) 1 Enable
				[4:2]		Pixel Phase Clock Select. Coarse adjustment for Pixel phase relative to INCLK. Useful in systems where Pixel inputs arrive with significant delay relative to INCLK.
				[1]		Sensor Polarity Select 0 Voltage increases with increasing white level 1 Voltage decreases with increasing white level
				[0]		Reserved

Table 18. Register Definitions (continued)

PAGE (DEC)	ADDR (DEC)	ADDR (HEX)	DEFAULT (BINARY)	BITS	REGISTER TITLE	REGISTER DESCRIPTION
0	4	4	0011 0000	[7]		Reserved
				[6]		Enable VCLP Buffer 0 Use resistor divider voltages directly 1 Use buffered resistor divider voltage
				[5]		Auto CLPIN Enable 0 Auto CLPIN Disabled 1 Auto CLPIN Enabled - (Default) - CLPIN generated according to Start and End position settings at Page 2, Registers 0x06 and 0x07
				[4]		CLPIN Gating Enable 0 Auto CLPIN not gated by the SAMPLE pulse timing 1 Auto CLPIN gated by the SAMPLE pulse timing (Default)
				[3]	Main Configuration 4	VCLP Power Down 0 VCLP Normal Operation 1 No circuit is tied to the VCLP output and no current is drawn
				[2:0]		VCLP Voltage Setting/Source 000 0.85V_A (Default) 001 0.9V_A 010 0.95V_A 011 0.6V_A 100 0.55V_A 101 0.4V_A 110 0.35V_A 111 0.15V_A

Table 18. Register Definitions (continued)

PAGE (DEC)	ADDR (DEC)	ADDR (HEX)	DEFAULT (BINARY)	BITS	REGISTER TITLE	REGISTER DESCRIPTION
0	5	5	0000 0000	[7]	Main Configuration 5	Output Format 0 LVDS (Default) 1 CMOS
				[6]		Output Enable. Enables the Data Output pins. 0 Disabled (Default) 1 Enable
				[5]		CMOS Data CLK Override Enable 0 - SH2 output as normal 1 - CMOS Data CLK on SH2
				[4:3]		Data Scrambler Enable/Mode 00 - Scrambler Disabled 01, 10, 11 - Scrambler Enabled see 1:0 description below for details:
				[2:1]		Data Scrambler Submode If Scrambler Mode = 01, Full scrambler enabled as follows: 00 Send lvds_data[20:0]^prs[20:0] 01 Send prs[20:0] 10 Send lvds_data[20:0]^pprs[20:0] 11 Send pprs[20:0] If Scrambler Mode = 10, 1 bit scrambler with key of prs[0] Send lvds_data[20:0]^prs[0], with lvds_data[k] = 0 00 k = 0 (DB0 in CMOS and 714 modes, CB0 in flexible, 16 bit mode) 01, txout0 disable = 0, k = 5 (DB0(lsb) in flexible, 16 bit mode) 01, txout0 disable = 1, k = 7 (DB2(lsb) in flexible, 14 bit mode) 10 k = 16 (CB0 in 714 mode) 11 k = 20 (CB4 in 714 mode) If Scrambler Mode = 11, 1 bit scrambler with key of lvds_data[k]. Send lvds_data[20:0]^lvds_data[k], with lvds_out[k] = lvds_data[k] 00 k = 0 (DB0 in CMOS and 714 modes, CB0 in flexible, 16 bit mode) 01, txout0 disable = 0, k = 5 (DB0(lsb) in flexible, 16 bit mode) 01, txout0 disable = 1, k = 7 (DB2(lsb) in flexible, 14 bit mode) 10 k = 16 (CB0 in 714 mode) 11 k = 20 (CB4 in 714 mode)
				[0]		Reserved

Table 18. Register Definitions (continued)

PAGE (DEC)	ADDR (DEC)	ADDR (HEX)	DEFAULT (BINARY)	BITS	REGISTER TITLE	REGISTER DESCRIPTION
0	6	6	0000 0000	[7] [6:4] [3] [2:0]	Configuration 6	LVDS Test Pattern Synchronization Select 0 Synchronizes at (held at initial state during) BOL & BOS 1 Synchronizes at (held at initial state during) BOS only LVDS Output Pattern Select 000 Select AFE output (normal operation) (Must be 00 for AFE Test Patterns) 001 Select 0x2A & 0x55 alternating patterns (all 3 pairs) 010 Selects 0x2A (all 3 pairs) 011 Selects 0x55 (all 3 pairs) 100 Selects 0x00 (all 4 pairs) (Differential 0 on all outputs) 101 Selects 0x7F (all 4 pairs) (Differential 1 on all outputs) AFE Test Pattern - Up-count Rate Select 0 Up-count at pixel rate 1 Up-count at BOL Test Pattern - AFE Data Select - (Bits 6:4 must be 000 for AFE Test Patterns) 000 Selects ADC output (normal operation) 001 Selects up-counter output 010 Selects 0xFF00 - fixed data 011 Selects 0xAA55 - fixed data 100 Selects 0x0000 - fixed data 101 Selects 0xFFFF - fixed data 110 Selects 0x00FF - fixed data 111 Selects 0x55AA - fixed data
0	7	7	0000 0000	[5] [4] [3] [2] [1] [0]	Configuration 7	Timing Generator Output Driver Strength PHIA1, PHIA2 - 0 = Normal, 1 = High PHIB1, PHIB2 - 0 = Normal, 1 = High PHIC1, PHIC2 - 0 = Normal, 1 = High RS - 0 = Normal, 1 = High CP - 0 = Normal, 1 = High SH1, SH2, SH3, SH4, SH5 - 0 = Normal, 1 = High
0	8	8	0000 0000	[7:6] [5:0]	OSR CLAMP Start Edge	Not Used CLAMP_R Start Edge - Default = 0d
0	9	9	0001 0000	[7:6] [5:0]	OSR CLAMP Stop Edge	Not Used CLAMP_R Stop Edge - Default = 16d
0	10	A	0000 0000	[7:6] [5:0]	OSG CLAMP Start Edge	Not Used CLAMP_G Start Edge - Default = 0d
0	11	B	0001 0000	[7:6] [5:0]	OSG CLAMP Stop Edge	Not Used CLAMP_G Stop Edge - Default = 16d
0	12	C	0000 0000	[7:6] [5:0]	OSB CLAMP Start Edge	Not Used CLAMP_B Start Edge - Default = 0d
0	13	D	0001 0000	[7:6] [5:0]	OSB CLAMP Stop Edge	Not Used CLAMP_B Stop Edge - Default = 16d
0	14	E	0001 0110	[7:6] [5:0]	OSR SAMPLE Start Edge	Not Used SAMPLE_R Start Edge - Default = 22d

Table 18. Register Definitions (continued)

PAGE (DEC)	ADDR (DEC)	ADDR (HEX)	DEFAULT (BINARY)	BITS	REGISTER TITLE	REGISTER DESCRIPTION
0	15	F	0010 0110	[7:6] [5:0]	OSR SAMPLE Stop Edge	Not Used SAMPLE_R Stop Edge - Default = 38d
0	16	10	0001 0110	[7:6] [5:0]	OSG SAMPLE Start Edge	Not Used SAMPLE_G Start Edge - Default = 22d
0	17	11	0010 0110	[7:6] [5:0]	OSG SAMPLE Stop Edge	Not Used SAMPLE_G Stop Edge - Default = 38d
0	18	12	0001 0110	[7:6] [5:0]	OSB SAMPLE Start Edge	Not Used SAMPLE_B Start Edge - Default = 22d
0	19	13	0010 0110	[7:6] [5:0]	OSB SAMPLE Stop Edge	Not Used SAMPLE_B Stop Edge - Default = 38d
0	20	14	0000 0000	[7] [6] [5:3] [2:0]	Sample & Clamp Monitor 0	Not Used SH_R Capture Monitor Override 0 SAMPB=SAMPB, CLAMPB=CLAMPB - Default 1 SAMPB = INCLK, CLAMPB = SH_R Selection bits for RS (user test mode) 000 Normal output 001 SAMPR Output 010 SAMPG Output 011 SAMPB Output 100 CLAMPR Output 101 CLAMPG Output 110 CLAMPB Output 111 PIXPHASE Output Selection bits for CP (user test mode) 000 Normal output 001 SAMPR Output 010 SAMPG Output 011 SAMPB Output 100 CLAMPR Output 101 CLAMPG Output 110 CLAMPB Output 111 PIXPHASE Output

Table 18. Register Definitions (continued)

PAGE (DEC)	ADDR (DEC)	ADDR (HEX)	DEFAULT (BINARY)	BITS	REGISTER TITLE	REGISTER DESCRIPTION
0	21	15	0000 0000	[7:6] [5:3] [2:0]	 Sample & Clamp Monitor 1	Not Used Selection bits for SH2 (user test mode) 000 Normal output 001 SAMPR Output 010 SAMPG Output 011 SAMPB Output 100 CLAMPR Output 101 CLAMPG Output 110 CLAMPB Output 111 PIXPHASE Output Selection bits for SH3 (user test mode) 000 Normal output 001 SAMPR Output 010 SAMPG Output 011 SAMPB Output 100 CLAMPR Output 101 CLAMPG Output 110 CLAMPB Output 111 PIXPHASE Output
0	22 to 29	16 to 1D	0000 0000		Reserved	
0	30	1E	XX00 0011	[7:0]	Revision	
0	31	1F	0000 0000	[3:0]	Page Register	Used to select desired page of registers being accessed 0000 Page 0 0001 Page 1 0010 Page 2 0011 Page 3 0100 Page 4 0101 Page 5 0110 Page 6 0111 Page 7 1000 Page 8

Table 18. Register Definitions (continued)

PAGE (DEC)	ADDR (DEC)	ADDR (HEX)	DEFAULT (BINARY)	BITS	REGISTER TITLE	REGISTER DESCRIPTION
PAGE 1						
1	0	0	0000 0000	[7] [6] [5] [4:3] [2] [1] [0]	Gain Mode	CDS/SH Gain Blue - 0 = 1x Gain, 1 = 2x Gain CDS/SH Gain Green - 0 = 1x Gain, 1 = 2x Gain CDS/SH Gain Blue - 0 = 1x Gain, 1 = 2x Gain Not used Individual CDS/SH Gain Enable 0 Use Bit 0 for CDS/SH Gain 1 Use Bits 7:5 for CDS/SH Gains Dual Gain Mode Enable 0 Single Gain Setting Within Each Line 1 Two Gain Settings Within Each Line Gain Select 0 1x CDS/SH Gain - Default 1 2x CDS/SH Gain
1	1	1	0110 0001	[7:0]	Red PGA	Default = 97d for Gain = 1
1	2	2	0110 0001	[7:0]	Green PGA	Default = 97d for Gain = 1
1	3	3	0110 0001	[7:0]	Blue PGA	Default = 97d for Gain = 1
1	4	4	1000 0000	[7:0]	Red Even DAC MSB	DAC[9:2]
1	5	5	0000 0000	[7:2] [1:0]	Red Even DAC LSB	Not Used DAC[1:0]
1	6	6	1000 0000	[7:0]	Green Even DAC MSB	DAC[9:2]
1	7	7	0000 0000	[7:2] [1:0]	Green Even DAC LSB	Not Used DAC[1:0]
1	8	8	1000 0000	[7:0]	Blue Even DAC MSB	DAC[9:2]
1	9	9	0000 0000	[7:2] [1:0]	Blue Even DAC LSB	Not Used DAC[1:0]
1	10	A	1000 0000	[7:0]	Red Odd DAC MSB	DAC[9:2]
1	11	B	0000 0000	[7:2] [1:0]	Red Odd DAC LSB	Not Used DAC[1:0]
1	12	C	1000 0000	[7:0]	Green Odd DAC MSB	DAC[9:2]
1	13	D	0000 0000	[7:2] [1:0]	Green Odd DAC LSB	Not Used DAC[1:0]
1	14	E	1000 0000	[7:0]	Blue Odd DAC MSB	DAC[9:2]

Table 18. Register Definitions (continued)

PAGE (DEC)	ADDR (DEC)	ADDR (HEX)	DEFAULT (BINARY)	BITS	REGISTER TITLE	REGISTER DESCRIPTION
1	15	F	0000 0000	[7:2] [1:0]	Blue Odd DAC LSB	Not Used DAC[1:0]
1	16	10	0100 0000	[7] [6:0]	Red Even Digital Offset	Not Used Digital Offset
1	17	11	0100 0000	[7] [6:0]	Green Even Digital Offset	Not Used Digital Offset
1	18	12	0100 0000	[7] [6:0]	Blue Even Digital Offset	Not Used Digital Offset
1	19	13	0100 0000	[7] [6:0]	Red Odd Digital Offset	Not Used Digital Offset
1	20	14	0100 0000	[7] [6:0]	Green Odd Digital Offset	Not Used Digital Offset
1	21	15	0100 0000	[7] [6:0]	Blue Odd Digital Offset	Not Used Digital Offset
1	22	16	0110 0001	[7:0]	Red High Gain PGA	PGA setting during high gain portion of line when dual gain mode is enabled Default = 97d for Gain = 1
1	23	17	0110 0001	[7:0]	Green High Gain PGA	PGA setting during high gain portion of line when dual gain mode is enabled Default = 97d for Gain = 1
1	24	18	0110 0001	[7:0]	Blue High Gain PGA	PGA setting during high gain portion of line when dual gain mode is enabled Default = 97d for Gain = 1
1	28	1C	0100 0000	[7] [6:0]	Red Channel Bimodal	Not Used Offset Binary Digital Offset for Bimodal Correction
1	29	1D	0100 0000	[7] [6:0]	Green Channel Bimodal	Not Used Offset Binary Digital Offset for Bimodal Correction
1	30	1E	0100 0000	[7] [6:0]	Blue Channel Bimodal	Not Used Offset Binary Digital Offset for Bimodal Correction
1	31	1F	0000 0000	[3:0]	Page Register	Used to select desired page of registers being accessed.

Table 18. Register Definitions (continued)

PAGE (DEC)	ADDR (DEC)	ADDR (HEX)	DEFAULT (BINARY)	BITS	REGISTER TITLE	REGISTER DESCRIPTION
PAGE 2						
2	0	0	0000 0000	[7:3] [2] [1:0]	Calibration Mode	Not Used DDAC Disable 0 AFE output includes DDAC (digital DAC offset) correction 1 AFE output does not include DDAC correction Calibration Mode 00 Black Calibration Only 01 White and Black Calibration - Full/Binary White Cal 10 White and Black Calibration - Fine Tuning 11 Reserved
2	1	1	0000 0000	[7:0]	Calibration # Lines	Calibration is active for this number of lines 0 Reserved 1d to 254d sets number of lines 255d sets infinite calibration
2	2	2	0001 0100	[5:4] [3:2] [1:0]	Black Cal Config	DDAC Scaling 00 Linear - 1 LSB adjust 01 Scaling = 1/2 10 Scaling = 1/4 11 Scaling = 1/8 ADAC Scaling 00 Reserved (No scaling) 01 Scaling = 1/2 10 Scaling = 1/4 11 Scaling = 1/8 Number of Black Pixels Number of pixels averaged by Black Loop 00 4 pixels 01 8 pixels 10 16 pixels 11 32 pixels
2	3	3	0100 0000	[7:0]	Black Target	Target level for Black calibration. Range is 0 to 255 at 11 bit level or 0 to 8160 at 16 bit level (default = 64 or 2048 at 16 bit level)

Table 18. Register Definitions (continued)

PAGE (DEC)	ADDR (DEC)	ADDR (HEX)	DEFAULT (BINARY)	BITS	REGISTER TITLE	REGISTER DESCRIPTION
2	4	4	0100 0011	[6:3] [2:0]	White Cal Config	White Loop Tolerance White Cal success if $ \text{White Peak} - \text{White Target} < \text{White Loop Tolerance}$ 0 to 15 at 10 bit level - Default = 8 Number of White Pixels Number of White Pixels processed in moving window average to find White Peak in line between White Pixels Start and White Pixels End 000 4 pixels 001 8 pixels 010 16 pixels 011 32 pixels - Default
2	5	5	1000 0000	[7:0]	White Target	White Target White Target = 768d + [7:0] at 10 bit level Range is 768d to 1023d at 10 bit level or 49152 to 65472 at 16 bit level (Default = 896d or 57344 at 16 bit level)
2	6	6	0000 0100	[7:0]	AutoCLPIN Start	# of pixels from SH interval End to Start of Black Pixel Clamping (Default = 4d)
2	7	7	0000 1100	[7:0]	AutoCLPIN End	# of pixels from SH interval End to End of Black Pixel Clamping (Default = 12d)
2	8	8	0001 0000	[7:0]	Black Loop Start	# of pixels from SH interval End to Start of Black Loop Pixels (Default = 16d)
2	9	9	0000 0000	[7:0]	Active/White Pixels Start - MSB	# of Pixels between SH Interval End and first Valid Data Pixel (Default = 64d)
2	10	A	0001 0100	[7:0]	Active/White Pixels Start - LSB	
2	11	B	0001 0000	[7:0]	Active/White Pixels End - MSB	# of Pixels between SH Interval End and last Valid Data Pixel (Default = 4096)
2	12	C	0000 0000	[7:0]	Active/White Pixels End - LSB	
2	13	D	0001 0000	[7:0]	Line Length MSB	# of Pixel Periods between beginning of consecutive SH Intervals (Default = 4160)
2	14	E	0100 0000	[7:0]	Line Length LSB	# of Pixel Periods between beginning of consecutive SH Intervals
2	15	F	0000 0000	[7:2] [1:0]	Line Length Multiplier	Not Used Multiplier factor for Active/White, LSPIX ON/OFF and Line Length Pixels Register Settings 00 1x 01 2x 10 4x

Table 18. Register Definitions (continued)

PAGE (DEC)	ADDR (DEC)	ADDR (HEX)	DEFAULT (BINARY)	BITS	REGISTER TITLE	REGISTER DESCRIPTION
2	16	10	0000 0000	[7] 6:5 4:3 [1:0]	Line Mode	Not Used CIS - 2 Color Coefficient Select Select which color PGA/DAC coefficients are used in 2 color CIS sequences 00 Red and Green Lamp/Coefficients Used 01 Green and Blue Lamp/Coefficients Used 10 Red and Blue Lamp/Coefficients Used 11 Reserved CCD/CIS Mode Select 00 Normal CCD Timing 01 CISa (2, 3, or 4 color sequences) 10 CISb (2 or 3 color sequences) 11 Reserved # SH Intervals. How many different SH intervals in a sequence of lines 00 1 SH Interval - Same SH timing every line 01 2 SH Intervals - 2 different SH interval timings 10 3 SH Intervals - 3 different SH interval timings 11 4 SH Intervals - 4 different SH interval timings SH States are allocated as follows: 1 Interval 1 = 0 to 30 2 Interval 1 = 0 to 14, Interval 2 = 15 to 30 3 Int 1 = 0 to 9, Int 2 = 10 to 19, Int 3 = 20 to 30 4 Int 1 = 0 to 6, Int 2 = 7 to 14, Int 3 = 15 to 22, Int 4 = 23 to 30
2	17	11	0000 0000	[7:3] [2:0]	SH State Length Multiplier	Not Used SH State Length values are multiplied by this factor 000 SH Timings x1 001 SH Timings x2 010 SH Timings x4 011 SH Timings x8 100 SH Timings x16 101 to 111 Reserved

Table 18. Register Definitions (continued)

PAGE (DEC)	ADDR (DEC)	ADDR (HEX)	DEFAULT (BINARY)	BITS	REGISTER TITLE	REGISTER DESCRIPTION
2	18	12	0000 0000	[7:6] [5] [4] [3] [2] [1] [0]	PHIA/B/C Delays	<p>Not Used</p> <p>PHIA On Delay 0 Normal 1 PHIA begins 1 pixel period late</p> <p>PHIA Off Delay 0 Normal 1 PHIA stops 1 pixel period late</p> <p>PHIB On Delay 0 Normal 1 PHIB begins 1 pixel period late</p> <p>PHIB Off Delay 0 Normal 1 PHIB stops 1 pixel period late</p> <p>PHIC On Delay 0 Normal 1 PHIC begins 1 pixel period late</p> <p>PHIC Off Delay 0 Normal 1 PHIC stops 1 pixel period late</p>
2	19	13	0000 0000	[7:4] [3] [2] [1] [0]	RS/CP Delays	<p>Not Used</p> <p>RS On Delay 0 Normal 1 RS begins 1 pixel period late</p> <p>RS Off Delay 0 Normal 1 RS stops 1 pixel period late</p> <p>CP On Delay 0 Normal 1 CP begins 1 pixel period late</p> <p>CP Off Delay 0 Normal 1 CP stops 1 pixel period late</p>
2	20 to 23	14 to 17			Reserved	

Table 18. Register Definitions (continued)

PAGE (DEC)	ADDR (DEC)	ADDR (HEX)	DEFAULT (BINARY)	BITS	REGISTER TITLE	REGISTER DESCRIPTION
2	24	18	1111 1000	[7:5] [4:3] [2:0]	PLL Control 1	Master PLL Range Setting for PLL1 and PLL2 when Autorange is off. Set to 111. PLL1 Charge Pump Current Control Default = 11 PLL1 Filter Bandwidth Control Default = 000
2	25	19	0001 1000	[7:5] [4:3] [2:0]	PLL Control 2	Reserved Default = 000 PLL2 Charge Pump Current Control Default = 11 Set to 00 when using SSCG. PLL2 Filter Bandwidth Control Default = 000 Set to 111 when using SSCG.
2	26	1A	0000 0000	[7:6] [5] [4] [3:2] [1] [0]	SSCG Control 1	Spread Rate Multiplier (Increases modulation frequency in low pixel frequency applications) 00 1x - Default 01 2x 10 4x (Page 2, Register D,E max = 32,768) 11 Reserved SSCG Spread Boost 0 Normal, PLL divide step is 1/28 1 Boost, PLL divide step is 1/56. Narrower and cleaner spread for 1ch and 2ch modes, but limits max pixel freq to 25 MHz. SSCG Spread Gain 0 Spread widths as specified in [3:2] 1 Spread widths are 2x [3:2] settings SSCG Spread Width (Fmod = Fcenter+/- Width/2) 00 5% 01 2.5% 10 1.25% 11 0.625% SSCG SH Sync Enable 0 Spread unsynched, once SSCG Enable is set, SSCG will begin immediately. 1 Spread synched to SH interval, once SSCG Enable is set, the SSCG will begin at the first SH Interval. SSCG Enable 0 Spread Disabled 1 Spread Enabled

Table 18. Register Definitions (continued)

PAGE (DEC)	ADDR (DEC)	ADDR (HEX)	DEFAULT (BINARY)	BITS	REGISTER TITLE	REGISTER DESCRIPTION
PAGE 3						
3	0	0	0000 0000	[7:0]	SH State 0 Length	Sets length of this SH interval state
3	1	1	0000 0000	[7:0]	SH State 1 Length	Sets length of this SH interval state
3	2	2	0000 0000	[7:0]	SH State 2 Length	Sets length of this SH interval state
3	3	3	0000 0000	[7:0]	SH State 3 Length	Sets length of this SH interval state
3	4	4	0000 0000	[7:0]	SH State 4 Length	Sets length of this SH interval state
3	5	5	0000 0000	[7:0]	SH State 5 Length	Sets length of this SH interval state
3	6	6	0000 0000	[7:0]	SH State 6 Length	Sets length of this SH interval state
3	7	7	0000 0000	[7:0]	SH State 7 Length	Sets length of this SH interval state
3	8	8	0000 0000	[7:0]	SH State 8 Length	Sets length of this SH interval state
3	9	9	0000 0000	[7:0]	SH State 9 Length	Sets length of this SH interval state
3	10	A	0000 0000	[7:0]	SH State 10 Length	Sets length of this SH interval state
3	11	B	0000 0000	[7:0]	SH State 11 Length	Sets length of this SH interval state
3	12	C	0000 0000	[7:0]	SH State 12 Length	Sets length of this SH interval state
3	13	D	0000 0000	[7:0]	SH State 13 Length	Sets length of this SH interval state
3	14	E	0000 0000	[7:0]	SH State 14 Length	Sets length of this SH interval state
3	15	F	0000 0000	[7:0]	SH State 15 Length	Sets length of this SH interval state
3	16	10	0000 0000	[7:0]	SH State 16 Length	Sets length of this SH interval state
3	17	11	0000 0000	[7:0]	SH State 17 Length	Sets length of this SH interval state
3	18	12	0000 0000	[7:0]	SH State 18 Length	Sets length of this SH interval state
3	19	13	0000 0000	[7:0]	SH State 19 Length	Sets length of this SH interval state
3	20	14	0000 0000	[7:0]	SH State 20 Length	Sets length of this SH interval state
3	21	15	0000 0000	[7:0]	SH State 21 Length	Sets length of this SH interval state
3	22	16	0000 0000	[7:0]	SH State 22 Length	Sets length of this SH interval state
3	23	17	0000 0000	[7:0]	SH State 23 Length	Sets length of this SH interval state
3	24	18	0000 0000	[7:0]	SH State 24 Length	Sets length of this SH interval state
3	25	19	0000 0000	[7:0]	SH State 25 Length	Sets length of this SH interval state
3	26	1A	0000 0000	[7:0]	SH State 26 Length	Sets length of this SH interval state

Table 18. Register Definitions (continued)

PAGE (DEC)	ADDR (DEC)	ADDR (HEX)	DEFAULT (BINARY)	BITS	REGISTER TITLE	REGISTER DESCRIPTION
3	27	1B	0000 0000	[7:0]	SH State 27 Length	Sets length of this SH interval state
3	28	1C	0000 0000	[7:0]	SH State 28 Length	Sets length of this SH interval state
3	29	1D	0000 0000	[7:0]	SH State 29 Length	Sets length of this SH interval state
3	30	1E	0000 0000	[7:0]	SH State 30 Length	Sets length of this SH interval state
3	31	1F		[3:0]	Page Register	

Table 18. Register Definitions (continued)

PAGE (DEC)	ADDR (DEC)	ADDR (HEX)	DEFAULT (BINARY)	BITS	REGISTER TITLE	REGISTER DESCRIPTION
PAGE 4						
4	0	0	0000 0000	[7] [6] [5] [4] [3] [2] [1] [0]	SH State 0 PHI, RS, CP	Controls whether these outputs are 1 or 0 during this SH interval state RS 0 = Low, 1 = High 1 0 = Low, 1 = High CP 0 = Low, 1 = High PHIA2 0 = Low, 1 = High PHIA1 0 = Low, 1 = High PHIB2 0 = Low, 1 = High PHIB1 0 = Low, 1 = High PHIC2 0 = Low, 1 = High PHIC1 0 = Low, 1 = High
4	1	1	0000 0000	[7:0]	SH State 1 PHI, RS, CP	Controls whether these outputs are 1 or 0 during this SH interval state
4	2	2	0000 0000	[7:0]	SH State 2 PHI, RS, CP	Controls whether these outputs are 1 or 0 during this SH interval state
4	3	3	0000 0000	[7:0]	SH State 3 PHI, RS, CP	Controls whether these outputs are 1 or 0 during this SH interval state
4	4	4	0000 0000	[7:0]	SH State 4 PHI, RS, CP	Controls whether these outputs are 1 or 0 during this SH interval state
4	5	5	0000 0000	[7:0]	SH State 5 PHI, RS, CP	Controls whether these outputs are 1 or 0 during this SH interval state
4	6	6	0000 0000	[7:0]	SH State 6 PHI, RS, CP	Controls whether these outputs are 1 or 0 during this SH interval state
4	7	7	0000 0000	[7:0]	SH State 7 PHI, RS, CP	Controls whether these outputs are 1 or 0 during this SH interval state
4	8	8	0000 0000	[7:0]	SH State 8 PHI, RS, CP	Controls whether these outputs are 1 or 0 during this SH interval state
4	9	9	0000 0000	[7:0]	SH State 9 PHI, RS, CP	Controls whether these outputs are 1 or 0 during this SH interval state
4	10	A	0000 0000	[7:0]	SH State 10 PHI, RS, CP	Controls whether these outputs are 1 or 0 during this SH interval state
4	11	B	0000 0000	[7:0]	SH State 11 PHI, RS, CP	Controls whether these outputs are 1 or 0 during this SH interval state
4	12	C	0000 0000	[7:0]	SH State 12 PHI, RS, CP	Controls whether these outputs are 1 or 0 during this SH interval state
4	13	D	0000 0000	[7:0]	SH State 13 PHI, RS, CP	Controls whether these outputs are 1 or 0 during this SH interval state
4	14	E	0000 0000	[7:0]	SH State 14 PHI, RS, CP	Controls whether these outputs are 1 or 0 during this SH interval state
4	15	F	0000 0000	[7:0]	SH State 15 PHI, RS, CP	Controls whether these outputs are 1 or 0 during this SH interval state
4	16	10	0000 0000	[7:0]	SH State 16 PHI, RS, CP	Controls whether these outputs are 1 or 0 during this SH interval state
4	17	11	0000 0000	[7:0]	SH State 17 PHI, RS, CP	Controls whether these outputs are 1 or 0 during this SH interval state
4	18	12	0000 0000	[7:0]	SH State 18 PHI, RS, CP	Controls whether these outputs are 1 or 0 during this SH interval state
4	19	13	0000 0000	[7:0]	SH State 19 PHI, RS, CP	Controls whether these outputs are 1 or 0 during this SH interval state
4	20	14	0000 0000	[7:0]	SH State 20 PHI, RS, CP	Controls whether these outputs are 1 or 0 during this SH interval state
4	21	15	0000 0000	[7:0]	SH State 21 PHI, RS, CP	Controls whether these outputs are 1 or 0 during this SH interval state

Table 18. Register Definitions (continued)

PAGE (DEC)	ADDR (DEC)	ADDR (HEX)	DEFAULT (BINARY)	BITS	REGISTER TITLE	REGISTER DESCRIPTION
4	22	16	0000 0000	[7:0]	SH State 22 PHI, RS, CP	Controls whether these outputs are 1 or 0 during this SH interval state
4	23	17	0000 0000	[7:0]	SH State 23 PHI, RS, CP	Controls whether these outputs are 1 or 0 during this SH interval state
4	24	18	0000 0000	[7:0]	SH State 24 PHI, RS, CP	Controls whether these outputs are 1 or 0 during this SH interval state
4	25	19	0000 0000	[7:0]	SH State 25 PHI, RS, CP	Controls whether these outputs are 1 or 0 during this SH interval state
4	26	1A	0000 0000	[7:0]	SH State 26 PHI, RS, CP	Controls whether these outputs are 1 or 0 during this SH interval state
4	27	1B	0000 0000	[7:0]	SH State 27 PHI, RS, CP	Controls whether these outputs are 1 or 0 during this SH interval state
4	28	1C	0000 0000	[7:0]	SH State 28 PHI, RS, CP	Controls whether these outputs are 1 or 0 during this SH interval state
4	29	1D	0000 0000	[7:0]	SH State 29 PHI, RS, CP	Controls whether these outputs are 1 or 0 during this SH interval state
4	30	1E	0000 0000	[7:0]	SH State 30 PHI, RS, CP	Controls whether these outputs are 1 or 0 during this SH interval state
4	31	1F		[3:0]	Page Register	

Table 18. Register Definitions (continued)

PAGE (DEC)	ADDR (DEC)	ADDR (HEX)	DEFAULT (BINARY)	BITS	REGISTER TITLE	REGISTER DESCRIPTION
PAGE 5						
5	0	0	0000 0000	[7:5] [4] [3] [2] [1] [0]	SH State 0 SH1-SH5	Not Used Controls whether these outputs are 1 or 0 during this SH interval state SH5 0 = Low, 1 = High SH4 0 = Low, 1 = High SH3 0 = Low, 1 = High SH2 0 = Low, 1 = High SH1 0 = Low, 1 = High
5	1	1	0000 0000	[4:0]	SH State 1 SH1-SH5	Controls whether these outputs are 1 or 0 during this SH interval state
5	2	2	0000 0000	[4:0]	SH State 2 SH1-SH5	Controls whether these outputs are 1 or 0 during this SH interval state
5	3	3	0000 0000	[4:0]	SH State 3 SH1-SH5	Controls whether these outputs are 1 or 0 during this SH interval state
5	4	4	0000 0000	[4:0]	SH State 4 SH1-SH5	Controls whether these outputs are 1 or 0 during this SH interval state
5	5	5	0000 0000	[4:0]	SH State 5 SH1-SH5	Controls whether these outputs are 1 or 0 during this SH interval state
5	6	6	0000 0000	[4:0]	SH State 6 SH1-SH5	Controls whether these outputs are 1 or 0 during this SH interval state
5	7	7	0000 0000	[4:0]	SH State 7 SH1-SH5	Controls whether these outputs are 1 or 0 during this SH interval state
5	8	8	0000 0000	[4:0]	SH State 8 SH1-SH5	Controls whether these outputs are 1 or 0 during this SH interval state
5	9	9	0000 0000	[4:0]	SH State 9 SH1-SH5	Controls whether these outputs are 1 or 0 during this SH interval state
5	10	A	0000 0000	[4:0]	SH State 10 SH1-SH5	Controls whether these outputs are 1 or 0 during this SH interval state
5	11	B	0000 0000	[4:0]	SH State 11 SH1-SH5	Controls whether these outputs are 1 or 0 during this SH interval state
5	12	C	0000 0000	[4:0]	SH State 12 SH1-SH5	Controls whether these outputs are 1 or 0 during this SH interval state
5	13	D	0000 0000	[4:0]	SH State 13 SH1-SH5	Controls whether these outputs are 1 or 0 during this SH interval state
5	14	E	0000 0000	[4:0]	SH State 14 SH1-SH5	Controls whether these outputs are 1 or 0 during this SH interval state
5	15	F	0000 0000	[4:0]	SH State 15 SH1-SH5	Controls whether these outputs are 1 or 0 during this SH interval state
5	16	10	0000 0000	[4:0]	SH State 16 SH1-SH5	Controls whether these outputs are 1 or 0 during this SH interval state
5	17	11	0000 0000	[4:0]	SH State 17 SH1-SH5	Controls whether these outputs are 1 or 0 during this SH interval state
5	18	12	0000 0000	[4:0]	SH State 18 SH1-SH5	Controls whether these outputs are 1 or 0 during this SH interval state
5	19	13	0000 0000	[4:0]	SH State 19 SH1-SH5	Controls whether these outputs are 1 or 0 during this SH interval state
5	20	14	0000 0000	[4:0]	SH State 20 SH1-SH5	Controls whether these outputs are 1 or 0 during this SH interval state
5	21	15	0000 0000	[4:0]	SH State 21 SH1-SH5	Controls whether these outputs are 1 or 0 during this SH interval state
5	22	16	0000 0000	[4:0]	SH State 22 SH1-SH5	Controls whether these outputs are 1 or 0 during this SH interval state

Table 18. Register Definitions (continued)

PAGE (DEC)	ADDR (DEC)	ADDR (HEX)	DEFAULT (BINARY)	BITS	REGISTER TITLE	REGISTER DESCRIPTION
5	23	17	0000 0000	[4:0]	SH State 23 SH1-SH5	Controls whether these outputs are 1 or 0 during this SH interval state
5	24	18	0000 0000	[4:0]	SH State 24 SH1-SH5	Controls whether these outputs are 1 or 0 during this SH interval state
5	25	19	0000 0000	[4:0]	SH State 25 SH1-SH5	Controls whether these outputs are 1 or 0 during this SH interval state
5	26	1A	0000 0000	[4:0]	SH State 26 SH1-SH5	Controls whether these outputs are 1 or 0 during this SH interval state
5	27	1B	0000 0000	[4:0]	SH State 27 SH1-SH5	Controls whether these outputs are 1 or 0 during this SH interval state
5	28	1C	0000 0000	[4:0]	SH State 28 SH1-SH5	Controls whether these outputs are 1 or 0 during this SH interval state
5	29	1D	0000 0000	[4:0]	SH State 29 SH1-SH5	Controls whether these outputs are 1 or 0 during this SH interval state
5	30	1E	0000 0000	[4:0]	SH State 30 SH1-SH5	Controls whether these outputs are 1 or 0 during this SH interval state
5	31	1F		[3:0]	Page Register	

Table 18. Register Definitions (continued)

PAGE (DEC)	ADDR (DEC)	ADDR (HEX)	DEFAULT (BINARY)	BITS	REGISTER TITLE	REGISTER DESCRIPTION
PAGE 6						
6	0	0	0000 0000	[1:0]	PHIA0	Upper 2 MSb (first shifted out of HSTG)
6	1	1	0000 0000	[7:0]	PHIA1	Next 8
6	2	2	0000 0000	[7:0]	PHIA2	Next 8
6	3	3	0000 0000	[7:0]	PHIA3	Next 8
6	4	4	0000 0000	[7:0]	PHIA4	Next 8
6	5	5	0000 0000	[7:0]	PHIA5	Lower 8 LSb (last shifted out of HSTG)
6	6	6	0000 0000	[1:0]	PHIB0	Upper 2 MSb (first shifted out of HSTG)
6	7	7	0000 0000	[7:0]	PHIB1	Next 8
6	8	8	0000 0000	[7:0]	PHIB2	Next 8
6	9	9	0000 0000	[7:0]	PHIB3	Next 8
6	10	A	0000 0000	[7:0]	PHIB4	Next 8
6	11	B	0000 0000	[7:0]	PHIB5	Lower 8 LSb (last shifted out of HSTG)
6	12	C	0000 0000	[1:0]	PHIC0	Upper 2 MSb (first shifted out of HSTG)
6	13	D	0000 0000	[7:0]	PHIC1	Next 8
6	14	E	0000 0000	[7:0]	PHIC2	Next 8
6	15	F	0000 0000	[7:0]	PHIC3	Next 8
6	16	10	0000 0000	[7:0]	PHIC4	Next 8
6	17	11	0000 0000	[7:0]	PHIC5	Lower 8 LSb (last shifted out of HSTG)
6	18	12	0000 0000	[1:0]	RS0	Upper 2 MSb (first shifted out of HSTG)
6	19	13	0000 0000	[7:0]	RS1	Next 8
6	20	14	0000 0000	[7:0]	RS2	Next 8
6	21	15	0000 0000	[7:0]	RS3	Next 8
6	22	16	0000 0000	[7:0]	RS4	Next 8
6	23	17	0000 0000	[7:0]	RS5	Lower 8 LSb (last shifted out of HSTG)
6	24	18	0000 0000	[1:0]	CP0	Upper 2 MSb (first shifted out of HSTG)
6	25	19	0000 0000	[7:0]	CP1	Next 8
6	26	1A	0000 0000	[7:0]	CP2	Next 8
6	27	1B	0000 0000	[7:0]	CP3	Next 8
6	28	1C	0000 0000	[7:0]	CP4	Next 8
6	29	1D	0000 0000	[7:0]	CP5	Lower 8 LSb (last shifted out of HSTG)
6	30	1E	0000 0000	[7:5] [4] [3] [2] [1] [0]	HSPIX Rate Select	Not Used Allows high speed generators to operate at 1/2 normal rate. So the full sequence will be clocked out over 2 pixels instead of 1 pixel PHIA 0 = Normal Rate, 1 = 1/2 Rate PHIB 0 = Normal Rate, 1 = 1/2 Rate PHIC 0 = Normal Rate, 1 = 1/2 Rate RS 0 = Normal Rate, 1 = 1/2 Rate CP 0 = Normal Rate, 1 = 1/2 Rate
6	31	1F		[3:0]	Page Register	

Table 18. Register Definitions (continued)

PAGE (DEC)	ADDR (DEC)	ADDR (HEX)	DEFAULT (BINARY)	BITS	REGISTER TITLE	REGISTER DESCRIPTION
PAGE 7						
7	0	0	0000 0000	[7:0]	SH1 PIXEL ON MSB	MSB of Pixel count where this signal goes low to high Range is 0 to 65535
7	1	1	0000 0000	[7:0]	SH1 PIXEL ON LSB	LSB of Pixel count where this signal goes low to high
7	2	2	0000 0000	[7:0]	SH1 PIXEL OFF MSB	MSB of Pixel count where this signal goes high to low Range is 0 to 65535
7	3	3	0000 0000	[7:0]	SH1 PIXEL OFF LSB	LSB of Pixel count where this signal goes high to low
7	4	4	0000 0000	[7:0]	SH2 PIXEL ON MSB	MSB of Pixel count where this signal goes low to high Range is 0 to 65535
7	5	5	0000 0000	[7:0]	SH2 PIXEL ON LSB	LSB of Pixel count where this signal goes low to high
7	6	6	0000 0000	[7:0]	SH2 PIXEL OFF MSB	MSB of Pixel count where this signal goes high to low Range is 0 to 65535
7	7	7	0000 0000	[7:0]	SH2 PIXEL OFF LSB	LSB of Pixel count where this signal goes high to low
7	8	8	0000 0000	[7:0]	SH3 PIXEL ON MSB	MSB of Pixel count where this signal goes low to high Range is 0 to 65535
7	9	9	0000 0000	[7:0]	SH3 PIXEL ON LSB	LSB of Pixel count where this signal goes low to high
7	10	A	0000 0000	[7:0]	SH3 PIXEL OFF MSB	MSB of Pixel count where this signal goes high to low Range is 0 to 65535
7	11	B	0000 0000	[7:0]	SH3 PIXEL OFF LSB	LSB of Pixel count where this signal goes high to low
7	12	C	0000 0000	[7:0]	SH4 PIXEL ON MSB	MSB of Pixel count where this signal goes low to high Range is 0 to 65535
7	13	D	0000 0000	[7:0]	SH4 PIXEL ON LSB	LSB of Pixel count where this signal goes low to high
7	14	E	0000 0000	[7:0]	SH4 PIXEL OFF MSB	MSB of Pixel count where this signal goes high to low Range is 0 to 65535
7	15	F	0000 0000	[7:0]	SH4 PIXEL OFF LSB	LSB of Pixel count where this signal goes high to low
7	16	10	0000 0000	[7:0]	SH5 PIXEL ON MSB	MSB of Pixel count where this signal goes low to high Range is 0 to 65535
7	17	11	0000 0000	[7:0]	SH5 PIXEL ON LSB	LSB of Pixel count where this signal goes low to high
7	18	12	0000 0000	[7:0]	SH5 PIXEL OFF MSB	MSB of Pixel count where this signal goes high to low Range is 0 to 65535

Table 18. Register Definitions (continued)

PAGE (DEC)	ADDR (DEC)	ADDR (HEX)	DEFAULT (BINARY)	BITS	REGISTER TITLE	REGISTER DESCRIPTION
7	19	13	0000 0000	[7:0]	SH5 PIXEL OFF LSB	LSB of Pixel count where this signal goes high to low
7	20	14	0000 0000	[7:4] [3] [2] [1] [0]	PHIA Polarity Override	Not Used Polarity Override Line 3 0 Signal Not Inverted 1 Signal Inverted Polarity Override Line 2 Polarity Override Line 1 Polarity Override Line 0
7	21	15	0000 0000	[7:4] [3] [2] [1] [0]	PHIB Polarity Override	Not Used Polarity Override Line 3 0 Signal Not Inverted 1 Signal Inverted Polarity Override Line 2 Polarity Override Line 1 Polarity Override Line 0
7	22	16	0000 0000	[7:4] [3] [2] [1] [0]	PHIC Polarity Override	Not Used Polarity Override Line 3 0 Signal Not Inverted 1 Signal Inverted Polarity Override Line 2 Polarity Override Line 1 Polarity Override Line 0
7	23	17	0000 0000	[7:4] [3] [2] [1] [0]	RS Polarity Override	Not Used Polarity Override Line 3 0 Signal Not Inverted 1 Signal Inverted Polarity Override Line 2 Polarity Override Line 1 Polarity Override Line 0
7	24	18	0000 0000	[7:4] [3] [2] [1] [0]	CP Polarity Override	Not Used Polarity Override Line 3 0 Signal Not Inverted 1 Signal Inverted Polarity Override Line 2 Polarity Override Line 1 Polarity Override Line 0

Table 18. Register Definitions (continued)

PAGE (DEC)	ADDR (DEC)	ADDR (HEX)	DEFAULT (BINARY)	BITS	REGISTER TITLE	REGISTER DESCRIPTION
7	25	19	0000 0000	[7:4] [3] [2] [1] [0]	SH1 Polarity Override	Not Used Polarity Override Line 3 0 Signal Not Inverted 1 Signal Inverted Polarity Override Line 2 Polarity Override Line 1 Polarity Override Line 0
7	26	1A	0000 0000	[7:4] [3] [2] [1] [0]	SH2 Polarity Override	Not Used Polarity Override Line 3 0 Signal Not Inverted 1 Signal Inverted Polarity Override Line 2 Polarity Override Line 1 Polarity Override Line 0
7	27	1B	0000 0000	[7:4] [3] [2] [1] [0]	SH3 Polarity Override	Not Used Polarity Override Line 3 0 Signal Not Inverted 1 Signal Inverted Polarity Override Line 2 Polarity Override Line 1 Polarity Override Line 0
7	28	1C	0000 0000	[7:4] [3] [2] [1] [0]	SH4 Polarity Override	Not Used Polarity Override Line 3 0 Signal Not Inverted 1 Signal Inverted Polarity Override Line 2 Polarity Override Line 1 Polarity Override Line 0
7	29	1D	0000 0000	[7:4] [3] [2] [1] [0]	SH5 Polarity Override	Not Used Polarity Override Line 3 0 Signal Not Inverted 1 Signal Inverted Polarity Override Line 2 Polarity Override Line 1 Polarity Override Line 0
7	30	1E	0000 0000		Reserved	
7	31	1F		[3:0]	Page Register	

Table 18. Register Definitions (continued)

PAGE (DEC)	ADDR (DEC)	ADDR (HEX)	DEFAULT (BINARY)	BITS	REGISTER TITLE	REGISTER DESCRIPTION
PAGE 8						
8	0	0	0000 0000	[7] [6] [5] [4] [3] [2] [1] [0]	PHIA1, PHIA2, Polarity / State	Not Used PHIA1 Active (0 = Tristate, 1* = Active) PHIA1 Source (0* = Timing, 1 = DC logic 1) PHIA1 Polarity (0* = Not Inverted, 1 = Inverted) Not Used PHIA2 Active (0 = Tristate, 1* = Active) PHIA2 Source (0* = Timing, 1 = DC logic 1) PHIA2 Polarity (0* = Not Inverted, 1 = Inverted)
8	1	1	0000 0000	[7] [6] [5] [4] [3] [2] [1] [0]	PHIB1, PHIB2, Polarity / State	Not Used PHIB1 Active (0 = Tristate, 1* = Active) PHIB1 Source (0* = Timing, 1 = DC logic 1) PHIB1 Polarity (0* = Not Inverted, 1 = Inverted) Not Used PHIB2 Active (0 = Tristate, 1* = Active) PHIB2 Source (0* = Timing, 1 = DC logic 1) PHIB2 Polarity (0* = Not Inverted, 1 = Inverted)
8	2	2	0000 0000	[7] [6] [5] [4] [3] [2] [1] [0]	PHIC1 PHIC2 Polarity / State	Not Used PHIC1 Active (0 = Tristate, 1* = Active) PHIC1 Source (0* = Timing, 1 = DC logic 1) PHIC1 Polarity (0* = Not Inverted, 1 = Inverted) Not Used PHIC2 Active (0 = Tristate, 1* = Active) PHIC2 Source (0* = Timing, 1 = DC logic 1) PHIC2 Polarity (0* = Not Inverted, 1 = Inverted)

Table 18. Register Definitions (continued)

PAGE (DEC)	ADDR (DEC)	ADDR (HEX)	DEFAULT (BINARY)	BITS	REGISTER TITLE	REGISTER DESCRIPTION
8	3	3	0000 0000	[7] [6] [5] [4] [3] [2] [1] [0]	RS, CP Polarity / State	Not Used RS Active (0 = Tristate, 1* = Active) RS Source (0* = Timing, 1 = DC logic 1) RS Polarity (0* = Not Inverted, 1 = Inverted) Not Used CP Active (0 = Tristate, 1* = Active) CP Source (0* = Timing, 1 = DC logic 1) CP Polarity (0* = Not Inverted, 1 = Inverted)
8	4	4	0000 0000	[7] [6] [5] [4] [3] [2] [1] [0]	SH1, SH2 Polarity / State	Not Used SH1 Active (0 = Tristate, 1* = Active) SH1 Source (0* = Timing, 1 = DC logic 1) SH1 Polarity (0* = Not Inverted, 1 = Inverted) Not Used SH2 Active (0 = Tristate, 1* = Active) SH2 Source (0* = Timing, 1 = DC logic 1) SH2 Polarity (0* = Not Inverted, 1 = Inverted)
8	5	5	0000 0000	[7] [6] [5] [4] [3] [2] [1] [0]	SH3, SH4 Polarity / State	Not Used SH3 Active (0 = Tristate, 1* = Active) SH3 Source (0* = Timing, 1 = DC logic 1) SH3 Polarity (0* = Not Inverted, 1 = Inverted) Not Used SH4 Active (0 = Tristate, 1* = Active) SH4 Source (0* = Timing, 1 = DC logic 1) SH4 Polarity (0* = Not Inverted, 1 = Inverted)
8	6	6	0000 0000	[7] [6] [5] [4] [3:0]	SH5 Polarity / State	Not Used SH5 Active (0 = Tristate, 1* = Active) SH5 Source (0* = Timing, 1 = DC logic 1) SH5 Polarity (0* = Not Inverted, 1 = Inverted) Not Used
8	7	7	0000 0000	[7:0]	Reserved	

Table 18. Register Definitions (continued)

PAGE (DEC)	ADDR (DEC)	ADDR (HEX)	DEFAULT (BINARY)	BITS	REGISTER TITLE	REGISTER DESCRIPTION
8	8	8	0010 0000	[7]	LVDS Configuration	LVDS TXCLK Disable 0 LVDS TXCLK Enabled - Default 1 LVDS TXCLK Disabled
				[6]		CMOS CLKOUT Disable 0 CMOS CLKOUT Enabled - Default 1 CMOS CLKOUT Disabled
				[5:4]		LVDS Drive Adjust 00 Reduce 100mV 01 Reduce 50 mV 10 Default 11 Increase 50 mV
				[3]		LVDS TXCLK Delay 0 TXCLK timing normal 1 TXCLK delayed
				[2]		BOL CB Bit Latency 0 Normal Compensation 1 No latency compensation
				[1]		LVDS Disable TXOUT0 0 TXOUT0 LVDS Pair Enabled 1 TXOUT0 LVDS Pair Disabled
				[0]		LVDS Mode Select 0 LM98714 1 Flexible CB Mapping

Table 18. Register Definitions (continued)

PAGE (DEC)	ADDR (DEC)	ADDR (HEX)	DEFAULT (BINARY)	BITS	REGISTER TITLE	REGISTER DESCRIPTION
8	9	9	0000 0000	[7:4]		Selects CB Bit Mapping CB1 Mapping 0000 CBO1 from LM98714 definition 0001 CBO0 from LM98714 definition 0010 CBO1 from LM98714 definition 0011 CBO2 from LM98714 definition 0100 CBO3 from LM98714 definition 0101 CBO4 from LM98714 definition 0110 R - High for a red channel pixel 0111 G - High for a green channel pixel 1000 B - High for a blue channel pixel 1001 Parity - 21 bit if TXOUT0 enabled, 14 bit if TXOUT0 disabled 1010 Ping - High for pixels processed by the Ping section of a channel, low for Pong 1011 Line#lsb - Line = 0 to 3 for lines 0 to 3 in multiline sequences 1100 Line#msb 1101 Black Loop Pixels - High for pixels processed by the Black Loop 1110 ActiveWhite Loop Pixels - High for pixels processed by the White Loop 1111 CLP Pixels - High for pixels where the input CLP switch is closed
				[3:0]	CB1/CB0 CB Mapping	CB0 Mapping 0000 CBO0 from LM98714 definition 0001 CBO0 from LM98714 definition 0010 CBO1 from LM98714 definition 0011 CBO2 from LM98714 definition 0100 CBO3 from LM98714 definition 0101 CBO4 from LM98714 definition 0110 R - High for a red channel pixel 0111 G - High for a green channel pixel 1000 B - High for a blue channel pixel 1001 Parity - 21 bit if TXOUT0 enabled, 14 bit if TXOUT0 disabled 1010 Ping - High for pixels processed by the Ping section of a channel, low for Pong 1011 Line#lsb - Line = 0 to 3 for lines 0 to 3 in multiline sequences 1100 Line#msb 1101 Black Loop Pixels - High for pixels processed by the Black Loop 1110 ActiveWhite Loop Pixels - High for pixels processed by the White Loop 1111 CLP Pixels - High for pixels where the input CLP switch is closed

Table 18. Register Definitions (continued)

PAGE (DEC)	ADDR (DEC)	ADDR (HEX)	DEFAULT (BINARY)	BITS	REGISTER TITLE	REGISTER DESCRIPTION
8	12	C	0000 0000	[7:4]		Selects CB Bit Mapping D4 Mapping 0000 D4 (Normal output for particular bit position) 0001 CBO0 from LM98714 definition 0010 CBO1 from LM98714 definition 0011 CBO2 from LM98714 definition 0100 CBO3 from LM98714 definition 0101 CBO4 from LM98714 definition 0110 R - High for a red channel pixel 0111 G - High for a green channel pixel 1000 B - High for a blue channel pixel 1001 Parity - 21 bit if TXOUT0 enabled, 14 bit if TXOUT0 disabled 1010 Ping - High for pixels processed by the Ping section of a channel, low for Pong 1011 Line#lsb - Line = 0 to 3 for lines 0 to 3 in multiline sequences 1100 Line#msb 1101 Black Loop Pixels - High for pixels processed by the Black Loop 1110 ActiveWhite Loop Pixels - High for pixels processed by the White Loop 1111 CLP Pixels - High for pixels where the input CLP switch is closed
				[3:0]	D4/D3 CB Mapping	D3 Mapping 0000 D4 (Normal output for particular bit position) 0001 CBO0 from LM98714 definition 0010 CBO1 from LM98714 definition 0011 CBO2 from LM98714 definition 0100 CBO3 from LM98714 definition 0101 CBO4 from LM98714 definition 0110 R - High for a red channel pixel 0111 G - High for a green channel pixel 1000 B - High for a blue channel pixel 1001 Parity - 21 bit if TXOUT0 enabled, 14 bit if TXOUT0 disabled 1010 Ping - High for pixels processed by the Ping section of a channel, low for Pong 1011 Line#lsb - Line = 0 to 3 for lines 0 to 3 in multiline sequences 1100 Line#msb 1101 Black Loop Pixels - High for pixels processed by the Black Loop 1110 ActiveWhite Loop Pixels - High for pixels processed by the White Loop 1111 CLP Pixels - High for pixels where the input CLP switch is closed

Table 18. Register Definitions (continued)

PAGE (DEC)	ADDR (DEC)	ADDR (HEX)	DEFAULT (BINARY)	BITS	REGISTER TITLE	REGISTER DESCRIPTION
8	13	D	0000 0000	[7:4] [3:0]	D5 CB Mapping	<p>Not Used</p> <p>Selects CB Bit Mapping</p> <p>D5 Mapping</p> <p>0000 D5 (Normal output for particular bit position)</p> <p>0001 CBO0 from LM98714 definition</p> <p>0010 CBO1 from LM98714 definition</p> <p>0011 CBO2 from LM98714 definition</p> <p>0100 CBO3 from LM98714 definition</p> <p>0101 CBO4 from LM98714 definition</p> <p>0110 R - High for a red channel pixel</p> <p>0111 G - High for a green channel pixel</p> <p>1000 B - High for a blue channel pixel</p> <p>1001 Parity - 21 bit if TXOUT0 enabled, 14 bit if TXOUT0 disabled</p> <p>1010 Ping - High for pixels processed by the Ping section of a channel, low for Pong</p> <p>1011 Line#lsb - Line = 0 to 3 for lines 0 to 3 in multiline sequences</p> <p>1100 Line#msb</p> <p>1101 Black Loop Pixels - High for pixels processed by the Black Loop</p> <p>1110 ActiveWhite Loop Pixels - High for pixels processed by the White Loop</p> <p>1111 CLP Pixels - High for pixels where the input CLP switch is closed</p>
8	14	E	0000 0000	[7] [6] [5] [4] [3] [2] [1] [0]	Unlock State Output Values PHIA, PHIB, PHIC, RS, CP	<p>Select level of CLK outputs during register updating (UNLOCK state)</p> <p>These can be modified during LOCK state to allow user to set up chip for what happens during the next UNLOCK state</p> <p>PHIA1 Unlock State 0 = Low, 1 = High</p> <p>PHIA2 Unlock State 0 = Low, 1 = High</p> <p>PHIB1 Unlock State 0 = Low, 1 = High</p> <p>PHIB2 Unlock State 0 = Low, 1 = High</p> <p>PHIC1 Unlock State 0 = Low, 1 = High</p> <p>PHIC2 Unlock State 0 = Low, 1 = High</p> <p>RS Unlock State 0 = Low, 1 = High</p> <p>CP Unlock State 0 = Low, 1 = High</p>

Table 18. Register Definitions (continued)

PAGE (DEC)	ADDR (DEC)	ADDR (HEX)	DEFAULT (BINARY)	BITS	REGISTER TITLE	REGISTER DESCRIPTION
8	21 to 30	15 to 1E	0000 0000		Reserved	
8	31	1F		[3:0]	Page Register	

8 Layout

8.1 Layout Example

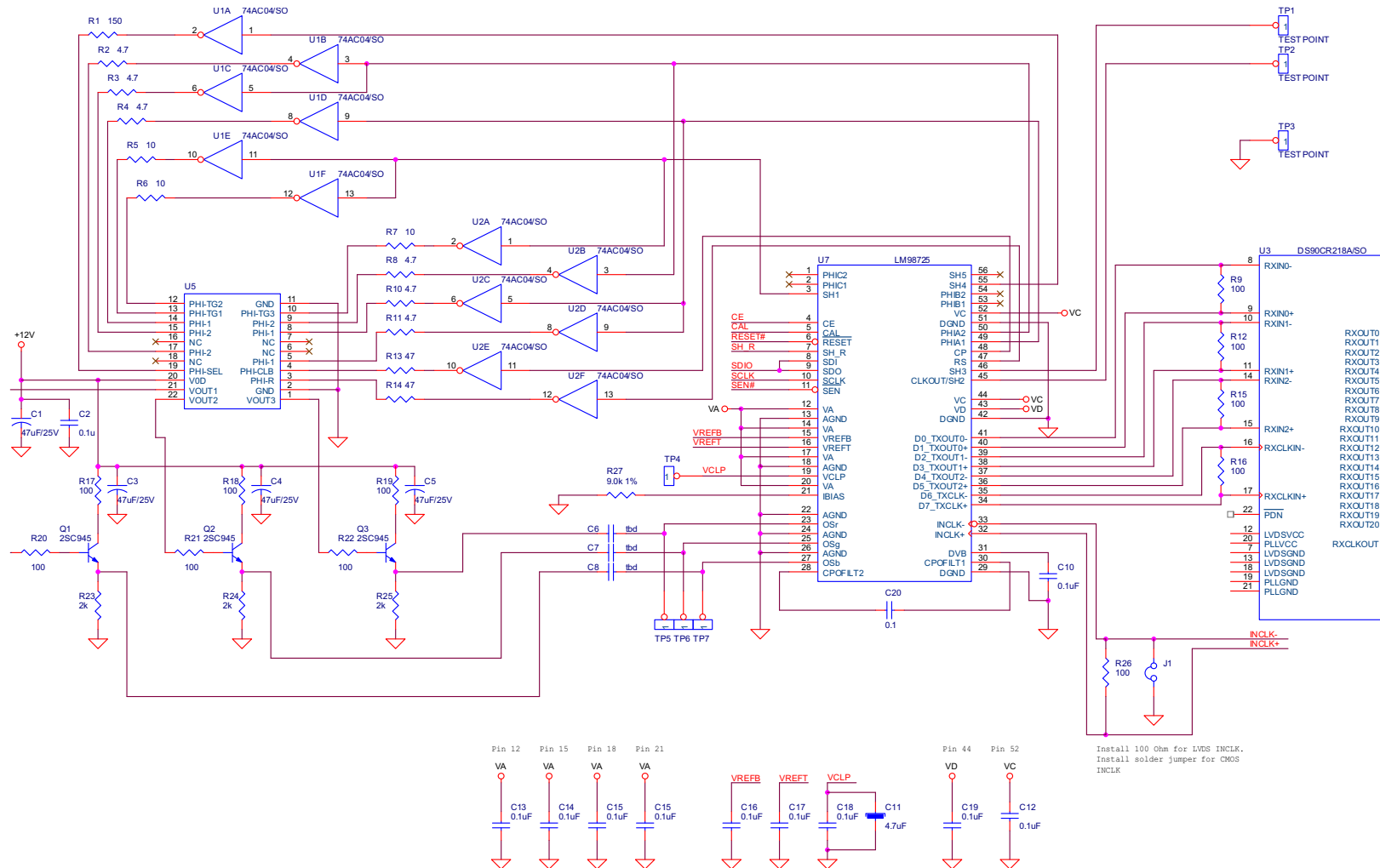

Figure 68. Example Application Circuit

9 Device and Documentation Support

9.1 Trademarks

All trademarks are the property of their respective owners.

9.2 Device Support

For additional information, see Texas Instruments' E2E community resources: <http://e2e.ti.com>.

9.3 Electrostatic Discharge Caution



These devices have limited built-in ESD protection. The leads should be shorted together or the device placed in conductive foam during storage or handling to prevent electrostatic damage to the MOS gates.

9.4 Glossary

[SLYZ022](#) — *TI Glossary*.

This glossary lists and explains terms, acronyms, and definitions.

10 Mechanical, Packaging, and Orderable Information

The following pages include mechanical, packaging, and orderable information. This information is the most current data available for the designated devices. This data is subject to change without notice and revision of this document. For browser-based versions of this data sheet, refer to the left-hand navigation.

PACKAGING INFORMATION

Orderable Device	Status (1)	Package Type	Package Drawing	Pins	Package Qty	Eco Plan (2)	Lead/Ball Finish (6)	MSL Peak Temp (3)	Op Temp (°C)	Device Marking (4/5)	Samples
LM98725CCMT/NOPB	ACTIVE	TSSOP	DGG	56	34	Green (RoHS & no Sb/Br)	CU SN	Level-2-260C-1 YEAR	0 to 70	LM98725CCMT	Samples
LM98725CCMTX/NOPB	ACTIVE	TSSOP	DGG	56	1000	Green (RoHS & no Sb/Br)	CU SN	Level-2-260C-1 YEAR	0 to 70	LM98725CCMT	Samples

(1) The marketing status values are defined as follows:

ACTIVE: Product device recommended for new designs.

LIFEBUY: TI has announced that the device will be discontinued, and a lifetime-buy period is in effect.

NRND: Not recommended for new designs. Device is in production to support existing customers, but TI does not recommend using this part in a new design.

PREVIEW: Device has been announced but is not in production. Samples may or may not be available.

OBsolete: TI has discontinued the production of the device.

(2) Eco Plan - The planned eco-friendly classification: Pb-Free (RoHS), Pb-Free (RoHS Exempt), or Green (RoHS & no Sb/Br) - please check <http://www.ti.com/productcontent> for the latest availability information and additional product content details.

TBD: The Pb-Free/Green conversion plan has not been defined.

Pb-Free (RoHS): TI's terms "Lead-Free" or "Pb-Free" mean semiconductor products that are compatible with the current RoHS requirements for all 6 substances, including the requirement that lead not exceed 0.1% by weight in homogeneous materials. Where designed to be soldered at high temperatures, TI Pb-Free products are suitable for use in specified lead-free processes.

Pb-Free (RoHS Exempt): This component has a RoHS exemption for either 1) lead-based flip-chip solder bumps used between the die and package, or 2) lead-based die adhesive used between the die and leadframe. The component is otherwise considered Pb-Free (RoHS compatible) as defined above.

Green (RoHS & no Sb/Br): TI defines "Green" to mean Pb-Free (RoHS compatible), and free of Bromine (Br) and Antimony (Sb) based flame retardants (Br or Sb do not exceed 0.1% by weight in homogeneous material)

(3) MSL, Peak Temp. - The Moisture Sensitivity Level rating according to the JEDEC industry standard classifications, and peak solder temperature.

(4) There may be additional marking, which relates to the logo, the lot trace code information, or the environmental category on the device.

(5) Multiple Device Markings will be inside parentheses. Only one Device Marking contained in parentheses and separated by a "~" will appear on a device. If a line is indented then it is a continuation of the previous line and the two combined represent the entire Device Marking for that device.

(6) Lead/Ball Finish - Orderable Devices may have multiple material finish options. Finish options are separated by a vertical ruled line. Lead/Ball Finish values may wrap to two lines if the finish value exceeds the maximum column width.

Important Information and Disclaimer: The information provided on this page represents TI's knowledge and belief as of the date that it is provided. TI bases its knowledge and belief on information provided by third parties, and makes no representation or warranty as to the accuracy of such information. Efforts are underway to better integrate information from third parties. TI has taken and continues to take reasonable steps to provide representative and accurate information but may not have conducted destructive testing or chemical analysis on incoming materials and chemicals. TI and TI suppliers consider certain information to be proprietary, and thus CAS numbers and other limited information may not be available for release.

In no event shall TI's liability arising out of such information exceed the total purchase price of the TI part(s) at issue in this document sold by TI to Customer on an annual basis.

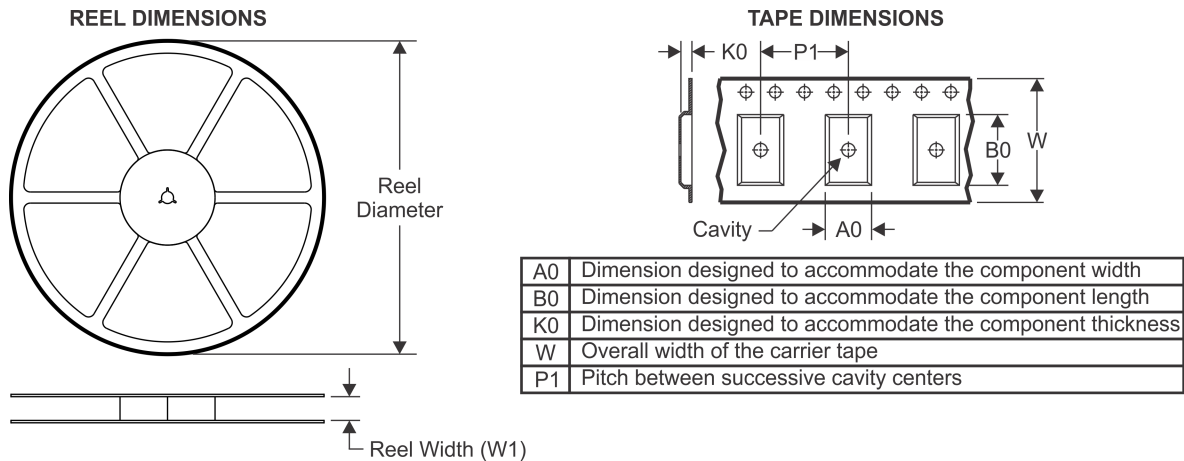
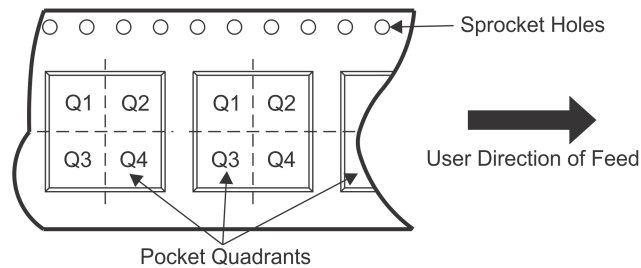
TAPE AND REEL INFORMATION

QUADRANT ASSIGNMENTS FOR PIN 1 ORIENTATION IN TAPE

*All dimensions are nominal

Device	Package Type	Package Drawing	Pins	SPQ	Reel Diameter (mm)	Reel Width W1 (mm)	A0 (mm)	B0 (mm)	K0 (mm)	P1 (mm)	W (mm)	Pin1 Quadrant
LM98725CCMTX/NOPB	TSSOP	DGG	56	1000	330.0	24.4	8.6	14.5	1.8	12.0	24.0	Q1

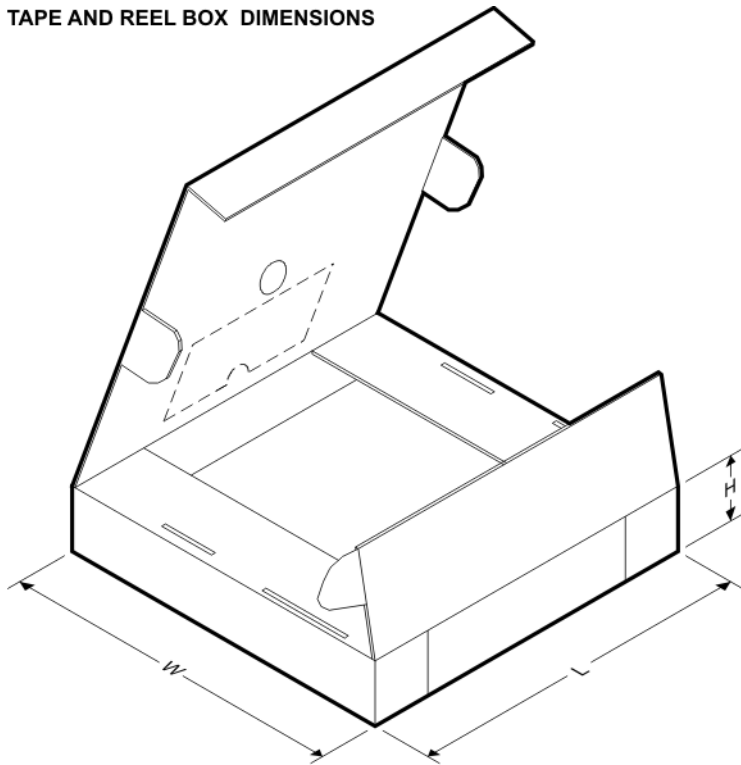
TAPE AND REEL BOX DIMENSIONS



*All dimensions are nominal

Device	Package Type	Package Drawing	Pins	SPQ	Length (mm)	Width (mm)	Height (mm)
LM98725CCMTX/NOPB	TSSOP	DGG	56	1000	367.0	367.0	45.0

DGG0056A



PACKAGE OUTLINE

TSSOP - 1.2 mm max height

SMALL OUTLINE PACKAGE

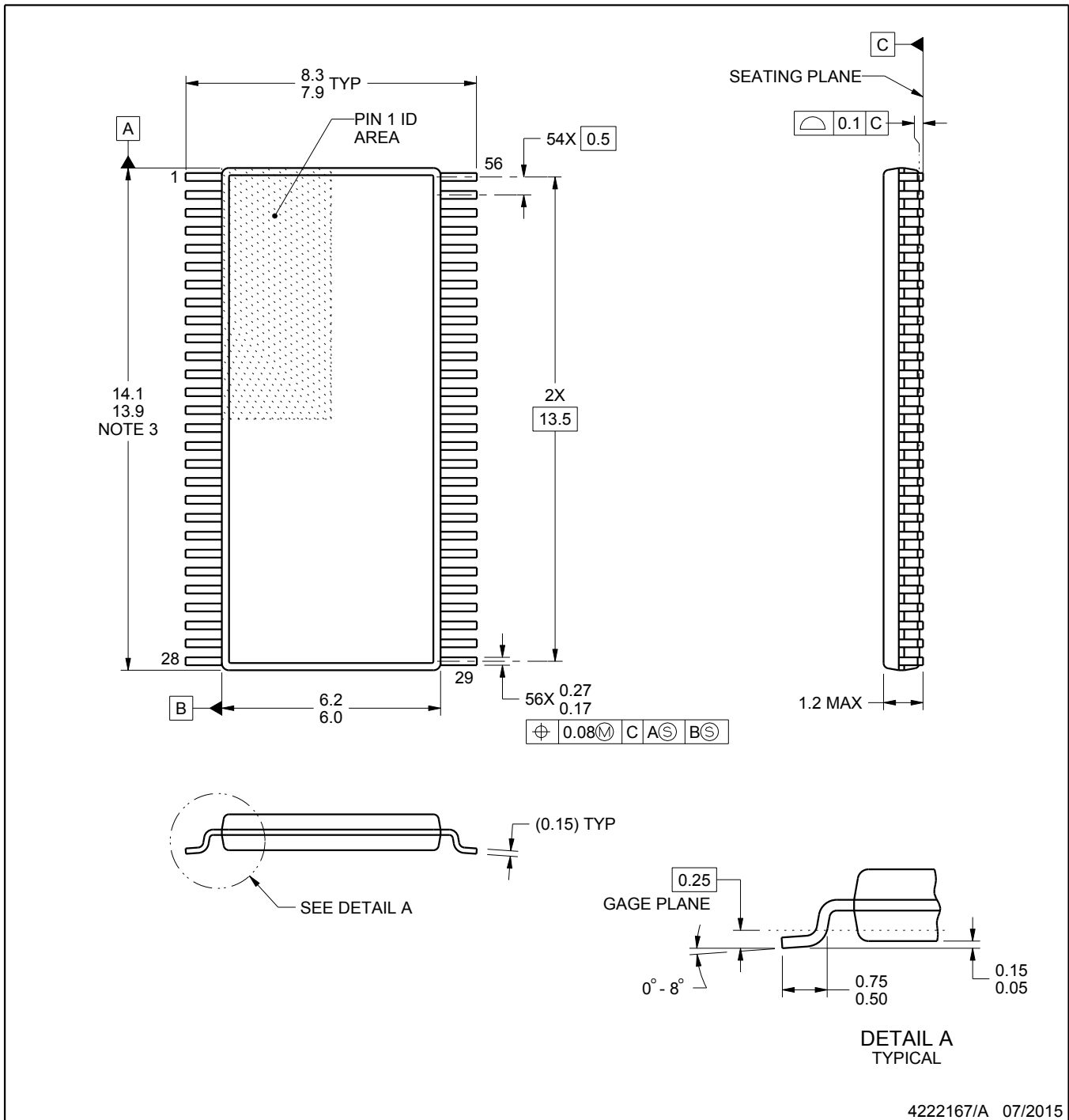

4222167/A 07/2015

NOTES:

- All linear dimensions are in millimeters. Any dimensions in parenthesis are for reference only. Dimensioning and tolerancing per ASME Y14.5M.
- This drawing is subject to change without notice.
- This dimension does not include mold flash, protrusions, or gate burrs. Mold flash, protrusions, or gate burrs shall not exceed 0.15 mm per side.
- Reference JEDEC registration MO-153.

EXAMPLE BOARD LAYOUT

DGG0056A

TSSOP - 1.2 mm max height

SMALL OUTLINE PACKAGE

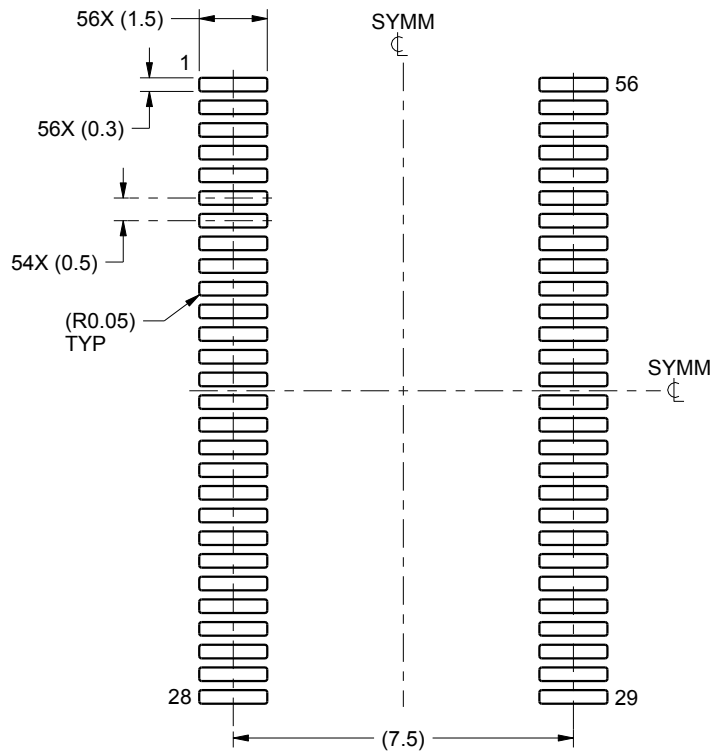

LAND PATTERN EXAMPLE
SCALE:6X

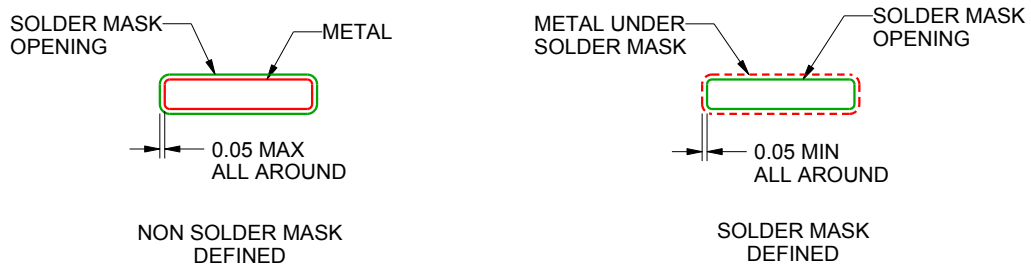

SOLDER MASK DETAILS

4222167/A 07/2015

NOTES: (continued)

- 5. Publication IPC-7351 may have alternate designs.
- 6. Solder mask tolerances between and around signal pads can vary based on board fabrication site.

EXAMPLE STENCIL DESIGN

DGG0056A

TSSOP - 1.2 mm max height

SMALL OUTLINE PACKAGE

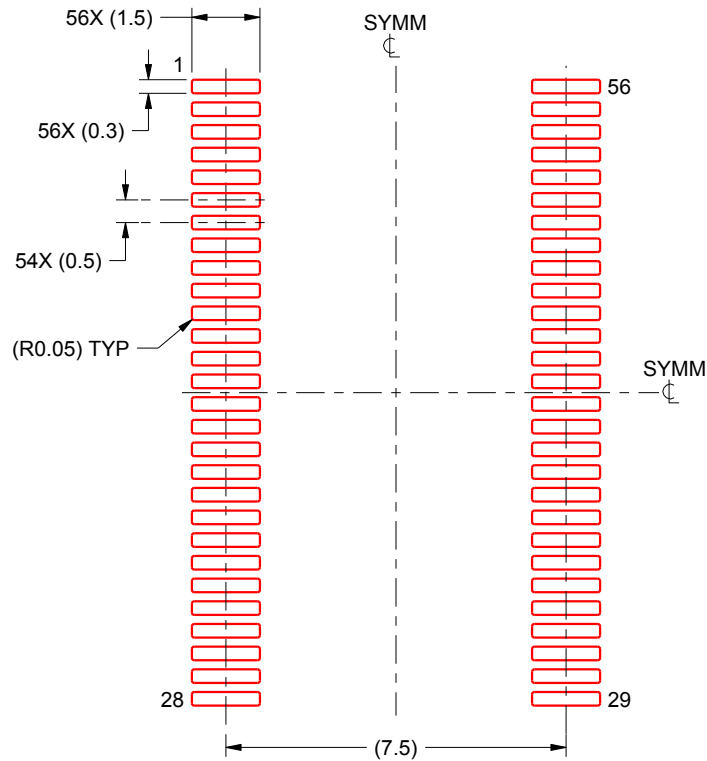

SOLDER PASTE EXAMPLE
BASED ON 0.125 mm THICK STENCIL
SCALE:6X

4222167/A 07/2015

NOTES: (continued)

7. Laser cutting apertures with trapezoidal walls and rounded corners may offer better paste release. IPC-7525 may have alternate design recommendations.
8. Board assembly site may have different recommendations for stencil design.

IMPORTANT NOTICE

Texas Instruments Incorporated and its subsidiaries (TI) reserve the right to make corrections, enhancements, improvements and other changes to its semiconductor products and services per JESD46, latest issue, and to discontinue any product or service per JESD48, latest issue. Buyers should obtain the latest relevant information before placing orders and should verify that such information is current and complete. All semiconductor products (also referred to herein as "components") are sold subject to TI's terms and conditions of sale supplied at the time of order acknowledgment.

TI warrants performance of its components to the specifications applicable at the time of sale, in accordance with the warranty in TI's terms and conditions of sale of semiconductor products. Testing and other quality control techniques are used to the extent TI deems necessary to support this warranty. Except where mandated by applicable law, testing of all parameters of each component is not necessarily performed.

TI assumes no liability for applications assistance or the design of Buyers' products. Buyers are responsible for their products and applications using TI components. To minimize the risks associated with Buyers' products and applications, Buyers should provide adequate design and operating safeguards.

TI does not warrant or represent that any license, either express or implied, is granted under any patent right, copyright, mask work right, or other intellectual property right relating to any combination, machine, or process in which TI components or services are used. Information published by TI regarding third-party products or services does not constitute a license to use such products or services or a warranty or endorsement thereof. Use of such information may require a license from a third party under the patents or other intellectual property of the third party, or a license from TI under the patents or other intellectual property of TI.

Reproduction of significant portions of TI information in TI data books or data sheets is permissible only if reproduction is without alteration and is accompanied by all associated warranties, conditions, limitations, and notices. TI is not responsible or liable for such altered documentation. Information of third parties may be subject to additional restrictions.

Resale of TI components or services with statements different from or beyond the parameters stated by TI for that component or service voids all express and any implied warranties for the associated TI component or service and is an unfair and deceptive business practice. TI is not responsible or liable for any such statements.

Buyer acknowledges and agrees that it is solely responsible for compliance with all legal, regulatory and safety-related requirements concerning its products, and any use of TI components in its applications, notwithstanding any applications-related information or support that may be provided by TI. Buyer represents and agrees that it has all the necessary expertise to create and implement safeguards which anticipate dangerous consequences of failures, monitor failures and their consequences, lessen the likelihood of failures that might cause harm and take appropriate remedial actions. Buyer will fully indemnify TI and its representatives against any damages arising out of the use of any TI components in safety-critical applications.

In some cases, TI components may be promoted specifically to facilitate safety-related applications. With such components, TI's goal is to help enable customers to design and create their own end-product solutions that meet applicable functional safety standards and requirements. Nonetheless, such components are subject to these terms.

No TI components are authorized for use in FDA Class III (or similar life-critical medical equipment) unless authorized officers of the parties have executed a special agreement specifically governing such use.

Only those TI components which TI has specifically designated as military grade or "enhanced plastic" are designed and intended for use in military/aerospace applications or environments. Buyer acknowledges and agrees that any military or aerospace use of TI components which have **not** been so designated is solely at the Buyer's risk, and that Buyer is solely responsible for compliance with all legal and regulatory requirements in connection with such use.

TI has specifically designated certain components as meeting ISO/TS16949 requirements, mainly for automotive use. In any case of use of non-designated products, TI will not be responsible for any failure to meet ISO/TS16949.

Products

Audio	www.ti.com/audio
Amplifiers	amplifier.ti.com
Data Converters	dataconverter.ti.com
DLP® Products	www.dlp.com
DSP	dsp.ti.com
Clocks and Timers	www.ti.com/clocks
Interface	interface.ti.com
Logic	logic.ti.com
Power Mgmt	power.ti.com
Microcontrollers	microcontroller.ti.com
RFID	www.ti-rfid.com
OMAP Applications Processors	www.ti.com/omap
Wireless Connectivity	www.ti.com/wirelessconnectivity

Applications

Automotive and Transportation	www.ti.com/automotive
Communications and Telecom	www.ti.com/communications
Computers and Peripherals	www.ti.com/computers
Consumer Electronics	www.ti.com/consumer-apps
Energy and Lighting	www.ti.com/energy
Industrial	www.ti.com/industrial
Medical	www.ti.com/medical
Security	www.ti.com/security
Space, Avionics and Defense	www.ti.com/space-avionics-defense
Video and Imaging	www.ti.com/video

TI E2E Community

e2e.ti.com



Looking for pricing, stock, or lifecycle information?

Click below to explore more details on WIN SOURCE:

 [View LM98725CCMTX/NOPB on WIN SOURCE](#)

 [Texas Instruments](#) Information

Optimize Your Supply Chain with WIN SOURCE Solutions

-  Global Sourcing Solution
-  Obsolete Management
-  Cost Control Management
-  Shortage Management
-  Alternative Solution
-  Excess Inventory Management