



**THE DATASHEET OF
LTC3490EDD#TRPBF**



FEATURES

- 350mA Constant Current Output
- 2.8V to 4V Output Compliance
- 1- or 2-Cell NiMH or Alkaline Input
- Synchronous Rectification: Up to 90% Efficiency
- Fixed Frequency Operation: 1.3MHz
- Low Quiescent Current: <1mA
- Very Low Shutdown Current: <50 μ A
- Open LED Output Limited to 4.7V
- V_{IN} Range: 1V to 3.2V
- Dimming Control
- Undervoltage Lockout to Protect Batteries
- Low Profile (0.75mm) 3mm \times 3mm Thermally Enhanced 8-Lead DD and S8 Packages

APPLICATIONS

- Portable Lighting
- Rechargeable Flashlights

DESCRIPTION

The LTC[®]3490 provides a constant current drive for 1W LED applications. It is a high efficiency boost converter that operates from 1 or 2 NiMH or alkaline cells and generates 350mA of constant current with up to 4V of compliance. It contains a 100m Ω NFET switch and a 130m Ω PFET synchronous rectifier. The fixed switching frequency is internally set to 1.3MHz.

The LTC3490 limits the output voltage to 4.7V if the output load is disconnected. It also features an analog dimming capability that reduces the drive current proportional to the CTRL/SHDN pin voltage. A low-battery logic output signals when the battery has dropped below 1V/cell. An undervoltage lockout circuit shuts down the LTC3490 when the battery voltage drops below 0.85V/cell. The feedback loop is internally compensated to minimize component count.

LT, LT, LTC and LTM are registered trademarks of Linear Technology Corporation. All other trademarks are the property of their respective owners.

TYPICAL APPLICATION

Single Cell Minimum Component LED Driver

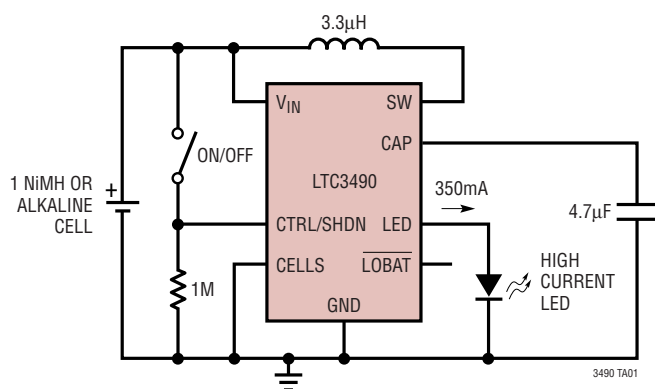

Efficiency vs V_{IN} at $V_{LED} = 3.5V$

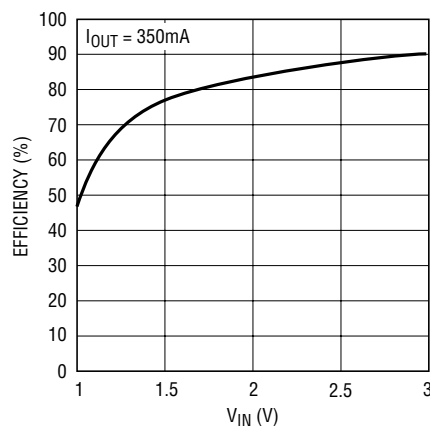

ABSOLUTE MAXIMUM RATINGS (Note 1)

Supply Voltage (V_{IN})	-0.3V to 6V	Operating Temperature Range (Note 2) ..	-40°C to 85°C
Input Voltages (CTRL/SHDN, CELLS)	-0.3V to 6V	Storage Temperature Range	-65°C to 125°C
Output Voltages (CAP, LED, SW)	-0.3V to 6V	Lead Temperature (Soldering, 10 sec, S8)	300°C

PACKAGE/ORDER INFORMATION

<p>DD PACKAGE 8-LEAD (3mm x 3mm) PLASTIC DFN</p> <p>$T_{JMAX} = 125^{\circ}C$, $\theta_{JA} = 43^{\circ}C/W$ (NOTE 4) EXPOSED PAD (PIN 9) IS GND MUST BE SOLDERED TO PCB (NOTE 5)</p>		<p>S8 PACKAGE 8-LEAD PLASTIC SO</p> <p>$T_{JMAX} = 125^{\circ}C$, $\theta_{JA} = 150^{\circ}C/W$ (NOTE 4)</p>	
ORDER PART NUMBER	DD PART MARKING	ORDER PART NUMBER	S8 PART MARKING
LTC3490EDD	LBRQ	LTC3490ES8	3490
Order Options Tape and Reel: Add #TR Lead Free: Add #PBF Lead Free Tape and Reel: Add #TRPBF Lead Free Part Marking: http://www.linear.com/leadfree/			

Consult LTC Marketing for parts specified with wider operating temperature ranges.

ELECTRICAL CHARACTERISTICS The ● denotes specifications which apply over the full operating temperature range, otherwise specifications are $T_A = 25^{\circ}C$. $V_{IN} = 2.5V$ unless otherwise specified.

SYMBOL	PARAMETER	CONDITIONS	MIN	TYP	MAX	UNITS
V_{IN}	Input Supply Range		1		3.2	V
$V_{IN(START)}$	Minimum Start-Up Voltage	(Note 3)		0.9	1	V
$I_{LED(MAX)}$	LED Drive Current	$V_{CTRL/SHDN} = V_{IN}$, DD Package 25°C to 85°C	330	350	370	mA
		-40°C to <25°C	310	350	385	mA
$I_{LED(SHDN)}$	LED Drive Current in Shutdown	$V_{CTRL/SHDN} = V_{IN}$, S8 Package 25°C to 85°C	337	350	363	mA
		-40°C to <25°C	325	345	365	mA
$I_{LED(SHDN)}$	LED Drive Current in Shutdown	$V_{CTRL/SHDN} = 0V$		0.1	1	μA
V_{LED}	Output Compliance Voltage		● 2.8		4	V
$V_{LED(OVL)}$	Output Voltage Overvoltage Limit	Open LED	● 4.2		4.7	V
$I_{IN(SHDN)}$	Input Current, Shutdown	$V_{CTRL/SHDN} = 0V$, Excluding Switch Leakage		20	50	μA
$I_{IN(ACTIVE)}$	Input Current, Active	Excluding Load Power		20	30	mA
f_{SW}	Switching Frequency		● 1.0	1.3	1.6	MHz
$I_{L(NMOS)}$	Leakage Current, NMOS Switch			0.1		μA
$R_{ON(NMOS)}$	On-Resistance, NMOS Switch			0.1		Ω

3490fa

ELECTRICAL CHARACTERISTICS

The ● denotes specifications which apply over the full operating temperature range, otherwise specifications are $T_A = 25^\circ\text{C}$. $V_{IN} = 2.5\text{V}$ unless otherwise specified.

SYMBOL	PARAMETER	CONDITIONS	MIN	TYP	MAX	UNITS
$I_{L(PMOS)}$	Leakage Current, PMOS Switch			0.1		μA
$R_{ON(PMOS)}$	On-Resistance, PMOS Switch			0.13		Ω
V_{IH}	Input High (CELLS)		$V_{IN} - 0.4$			V
	Input High (SHDN)			$V_{IN} \cdot 0.9$		V
V_{IL}	Input Low (CELLS)				0.4	V
	Input Low (SHDN)			$V_{IN} \cdot 0.2$		V
I_{IN}	Input Current (CTRL/SHDN, CELLS)			0.01		μA
K_{CTRL}	Control Gain, I_{LED}/V_{CTRL}	Scales Linearity with V_{IN} , $V_{IN} = 1\text{V}$		500		mA/V
$R_{ON(LOBAT)}$	On-Resistance, $\overline{\text{LOBAT}}$ Output	$V_{IN} < V_{IN(LOBAT)}$	●		300	Ω
$V_{IN(LOBAT1)}$	Input Voltage, Low Battery, 1 Cell	$V_{CELLS} = 0\text{V}$	●	0.8	1.12	V
$V_{IN(LOBAT2)}$	Input Voltage, Low Battery, 2 Cells	$V_{CELLS} = V_{IN}$	●	1.8	2.24	V
$V_{IN(UVL02)}$	Input Voltage, Undervoltage Lockout, 2 Cells	$V_{CELLS} = V_{IN}$	●	1.4	1.8	V
$V_{IN(UVL01)}$	Input Voltage, Undervoltage Lockout, 1 Cell	$V_{CELLS} = 0\text{V}$	●	0.7	0.9	V

Note 1: Stresses beyond those listed under Absolute Maximum Ratings may cause permanent damage to the device. Exposure to any Absolute Maximum Rating condition for extended periods may affect device reliability and lifetime.

Note 2: The LTC3490 is guaranteed to meet performance specifications from 0°C to 70°C . Specifications over the -40°C to 85°C range are assured by design, characterization and correlation with statistical process controls.

Note 3: The LTC3490 input voltage may drop below the minimum start-up voltage once the LED voltage has risen above 2.3V.

Note 4: This device includes overtemperature protection intended to protect the device during momentary overload conditions. The maximum junction temperature may be exceeded when overtemperature protection is active. Continuous operation above the specified maximum operating junction temperature may result in device degradation or failure.

Note 5: The Exposed Pad of the DFN package must be soldered to a PCB pad for optimum thermal conductivity. This pad must be connected to ground.

TYPICAL PERFORMANCE CHARACTERISTICS

Oscillator Frequency vs Temperature

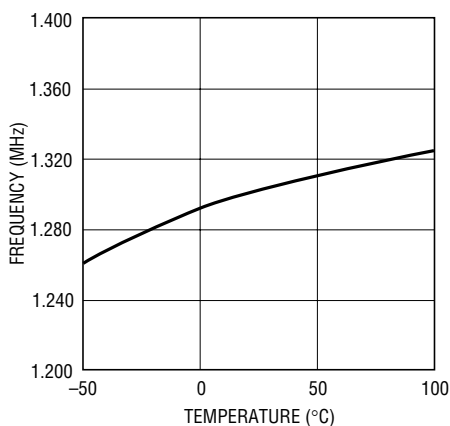

3490 G01

I_{LED} vs V_{CTRL}

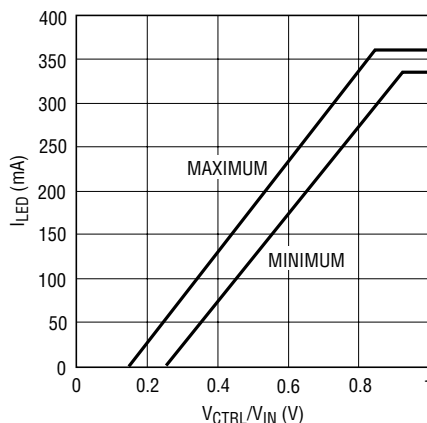

3490 G02

I_{LED} vs V_{IN}

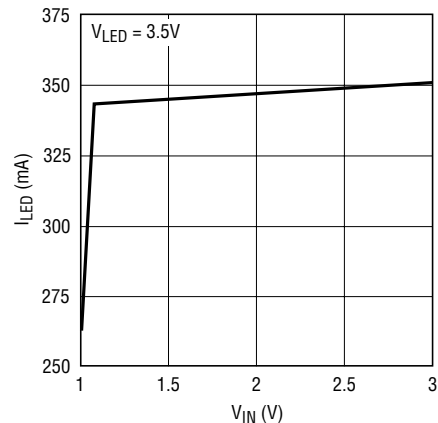

3490 G03

3490fa

TYPICAL PERFORMANCE CHARACTERISTICS

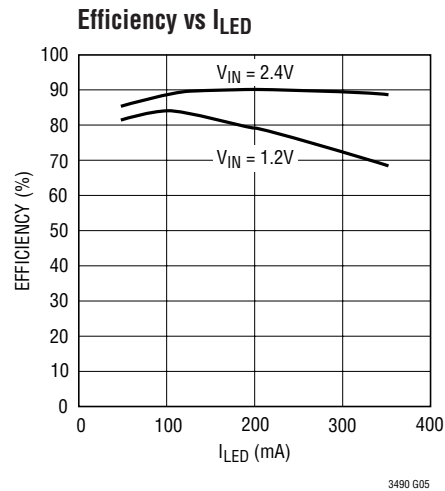
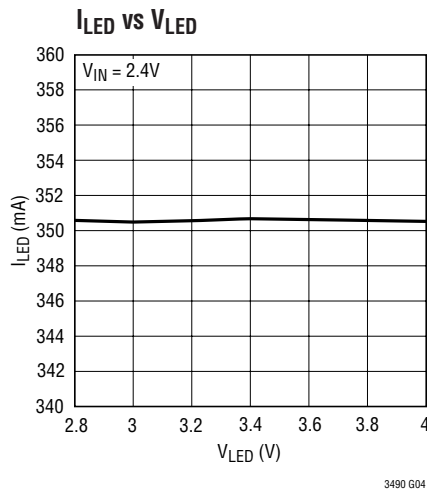

PIN FUNCTIONS

CELLS (Pin 1): A logic input to set the low-battery and undervoltage shutdown thresholds. A logic low (tied to GND) will set the thresholds for 1 cell. A logic high (tied to V_{IN}) will set the thresholds for 2 cells.

V_{IN} (Pin 2): Supply Voltage.

SW (Pin 3): Switch Input. Connect this pin to an external inductor from V_{IN} .

GND (Pin 4): Circuit Ground.

LED (Pin 5): Output Drive Current to LED.

CAP (Pin 6): Filter Capacitor. A 4.7 μ F low ESR capacitor should be tied to this pin.

LOBAT (Pin 7): Low active, open-drain logic output indicating a low-battery condition.

CTRL/SHDN (Pin 8): Analog Control Voltage and Shutdown. When $V_{IN} \cdot 0.2 < V_{CTRL} < V_{IN} \cdot 0.9$, the LED drive current varies according to the formula:

$$I_{LED} = 500 \cdot \left(\frac{V_{CTRL}}{V_{IN}} - 0.2 \right) \text{ mA}$$

When $V_{CTRL} > V_{IN} \cdot 0.9$, the LED drive current is clamped at 350mA. When $V_{CTRL} < V_{IN} \cdot 0.2$, then the part is in low power shutdown.

Exposed Pad (Pin 9, DD Package): Ground. This pin must be soldered to the PCB to provide both electrical contact to ground and good thermal contact to the PCB.

OPERATION

The LTC3490 is a high efficiency, constant current source for 1W high intensity white LEDs. These high intensity LEDs require a fixed current of 350mA with a voltage compliance of 2.8V to 4V.

The LTC3490 operates with 1 or 2 NiMH or alkaline cells. It functions as a boost converter with a current sense resistor providing the control feedback. If the battery voltage is greater than the required LED compliance, it will cycle off periodically to maintain the correct average current. It features a low voltage start-up circuit that will start with an input voltage of only 1V. Once the drive voltage exceeds 2.3V, the circuit operates from the drive voltage.

All of the loop compensation is internal; only the main filter capacitor is needed for stable operation.

Dimming Function

During normal operation with the CTRL/SHDN pin connected to V_{IN} , the LED drive current is controlled at 350mA. The drive current can be reduced by changing the voltage on the CTRL/SHDN pin.

For $V_{IN} \cdot 0.2 < V_{CTRL} < V_{IN} \cdot 0.9$, the LED current is proportional to V_{CTRL}/V_{IN} . This allows a simple potentiometer from V_{IN} to control the current without sensitivity

to the battery voltage. The LED drive current is given by the formula:

$$I_{LED} = 500 \cdot \left(\frac{V_{CTRL}}{V_{IN}} - 0.2 \right) \text{mA}$$

When $V_{CTRL} > V_{IN} \cdot 0.9$, the LED drive current is clamped at 350mA.

Open-Circuit Protection

Since this is a boost converter attempting to drive a current into the load, an open or high impedance load will cause the regulator loop to increase the output voltage in an effort to achieve regulation. To protect the device, maximum output voltage is limited to 4.7V under all conditions.

Undervoltage Sense and Protection

The undervoltage lockout prevents excessive inductor peak current and protects the batteries from deep discharging which can damage them. The low-battery indicator allows the end user to be made aware that the batteries are nearing the end of their useful life.

APPLICATIONS INFORMATION

The LTC3490 requires only four external components to operate: an inductor, an output capacitor, a switch and a pull-down resistor. The inductor is nominally set at 3.3μH and the capacitor at 4.7μF. Optional components include an input capacitor and dimming resistors.

COMPONENT SELECTION

Inductor Selection

The high frequency operation of the LTC3490 allows the use of small surface mount inductors. The minimum inductance value is proportional to the operating frequency and is limited by the following constraints:

$$L \geq \frac{3}{f} \text{H}$$

and

$$L \geq \frac{V_{IN(MIN)} \cdot (V_{OUT(MAX)} - V_{IN(MIN)})}{f \cdot \text{Ripple} \cdot V_{OUT(MAX)}} \text{H}$$

where:

f = Operating Frequency (Hz)

Ripple = Inductor Current Ripple (A)

$V_{IN(MIN)}$ = Minimum Input Voltage (V)

$V_{OUT(MAX)}$ = Maximum Output Voltage (V)

The inductor current ripple is typically set to 20% to 40% of the inductor current.

The peak inductor current is given by:

$$I_{LPK} = I_{OUT} \frac{(V_{OUT} + I_{OUT} \cdot R_P) - R_N \cdot I_{IN}}{V_{IN} - R_N \cdot I_{IN}} + \frac{V_{IN}(V_{OUT} - V_{IN})}{2 \cdot L \cdot f \cdot V_{OUT}}$$

where:

V_{IN} = Input Voltage (V)

V_{OUT} = Output Voltage (V)

I_{OUT} = LED Drive Current (A)

I_{IN} = Input Current = $V_{OUT}/V_{IN} \cdot I_{OUT}$ (A)

R_P = $R_{DS(ON)}$ of the PFET Switch (Ω)

R_N = $R_{DS(ON)}$ of the NFET Switch (Ω)

For high efficiency, choose an inductor with a high frequency core material, such as ferrite, to reduce core losses. The inductor should have low ESR (equivalent series resistance) to reduce the I^2R losses and must be able to handle the peak inductor current at full load without saturating. In single cell applications, the inductor ESR must be below 25mΩ to keep the efficiency up and maintain output current regulation. Dual cell applications can tolerate significantly higher ESR (up to 75mΩ) with minimal efficiency degradation. Molded chokes or chip inductors usually do not have enough core to support the peak inductor currents in the 1A to 2A region. If radiated noise is an issue, use a toroid, pot core or shielded bobbin inductor to minimize radiated noise. See Table 1 for a list of suggested inductors. Look closely at the manufacturers data sheets; they specify saturation current differently.

Table 1. Inductor Information

INDUCTOR PART NUMBER	ESR (mΩ)	SATURATION CURRENT (A)
TOKO A918CY-3R3M	47	1.97
TYCO DN4835-3R3M	58	2.15
TDK SLF7045T-3R3M2R5	20	2.5

Output Capacitor Selection

The output capacitor value and equivalent series resistance (ESR) are the primary factors in the output ripple. The output ripple is not a direct concern for LED drive as the LED will operate at the average current value. However the peak pulsed forward current rating of the LED must not be exceeded to avoid damaging the LED.

APPLICATIONS INFORMATION

The output ripple voltage has two primary components. The first is due to the value of the capacitor and is given by:

$$V_{R_{CAP}} = \frac{I_{LPK} \cdot V_{IN}}{C \cdot V_{OUT} \cdot f}$$

The second is due to the capacitor ESR:

$$V_{R_{ESR}} = I_{LPK} \cdot R_{ESR}$$

The LED current ripple and peak pulsed current are calculated by:

$$I_{R_{LED}} = \frac{V_{R_{CAP}} \cdot V_{R_{ESR}}}{R_{SENSE} + R_{LED}}$$

$$I_{PPFC} = I_{OUT} + \frac{I_{R_{LED}}}{2}$$

where:

R_{SENSE} = Internal Sense Resistor = 0.1 Ω

R_{LED} = Dynamic Impedance of the LED

Low ESR capacitors should be used to minimize output ripple. Ceramic X5R or X7R type capacitors are recommended. See Table 2 for a list of component suppliers.

Table 2. Capacitor Information

CAPACITOR PART NUMBER	DESCRIPTION
TDK C2012X5R0J475K	4.7 μ F, 6.3V, X5R in 0805
AVX 1210ZC475MAT	4.7 μ F, 10V, X7R in 1210
Taiyo Yuden CELMK316BJ475ML	4.7 μ F, 10V, X7R in 1206

Input Capacitor Selection

Most battery-powered applications do not need an input capacitor. In supply-powered applications or battery applications with long leads to the battery, a low ESR 3.3 μ F capacitor reduces switching noise and peak currents.

Design Example

The example will use a Lumileds DS25 white LED. The key specifications are:

$$V_F \text{ (at } I_F = 350\text{mA)} = 3.4 \pm 0.6\text{V}$$

$$R_{LED} = 1\Omega$$

$$\text{Peak Pulsed Forward Current} = 0.5\text{A}$$

Component values will be calculated for 1 or 2 NiMH cells and assumes the end-of-charge voltage to be 0.9V per cell. The operating frequency is assumed to be 1MHz, the worst-case low frequency. The allowed inductor ripple current is 0.31A. Table 3 shows a summary of the key parameters.

Table 3. Summary of Key Parameters

PARAMETER	1-CELL	2-CELL	UNITS
L_{MIN}	2.2	3.2	μ H
Choose L	3.3	3.3	μ H
I_{IN}	1.56	0.78	A
I_{LPK}	1.93	0.96	A
Choose C	4.7	4.7	μ F
Cap ESR	5	5	m Ω
$V_{R_{CAP}}$	0.09	0.09	V
$V_{R_{ESR}}$	0.01	0.005	V
$I_{R_{LED}}$	0.10	0.09	A
I_{PPFC}	0.40	0.39	A

where:

I_{LPK} is the peak inductor current

$V_{R_{CAP}}$ is the ripple voltage due to the output capacitor value

$V_{R_{ESR}}$ is the ripple voltage due to the output capacitor ESR

$I_{R_{LED}}$ is the LED current ripple

I_{PPFC} is the LED peak pulsed forward current

PC Board Layout Checklist

Keep the inductor and output capacitor as close to the IC as possible. Make traces as short and wide as is feasible. Parasitic resistance and inductance reduce efficiency and increase ripple.

Keep resistance in the battery connections as low as possible. In single cell applications, only 0.1 Ω in the battery connections will have a dramatic effect in efficiency and battery life. I^2R losses can exceed 100mW and the converter operates lower on the efficiency curve.

APPLICATIONS INFORMATION

Red Luxeon LEDs

The red, red-orange and amber Luxeon LEDs have a lower forward voltage than the white, blue and green LEDs. Since the LTC3490 internal circuitry is powered from the output, it requires a minimum LED voltage of 2.5V for reliable operation. The minimum forward voltage on the red LEDs

is only 2.31V. The LTC3490 requires an additional 190mV for proper operation. In non-dimming applications, this can be accomplished with a 0.6Ω resistor in series with the LED. The resistor voltage drops too low in dimming applications, so a Schottky diode is recommended to keep sufficient voltage at the output at lower currents.

TYPICAL APPLICATIONS

2-Cell Adjustable Amplitude LED Driver

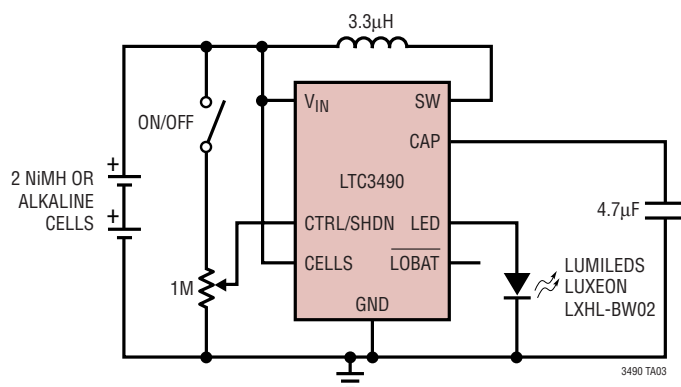

Soft Turn-Off LED Driver

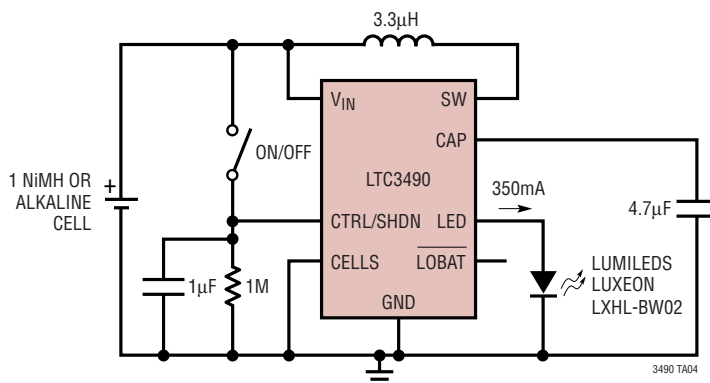

TYPICAL APPLICATIONS

Luxeon Red LED Driver Without Dimming

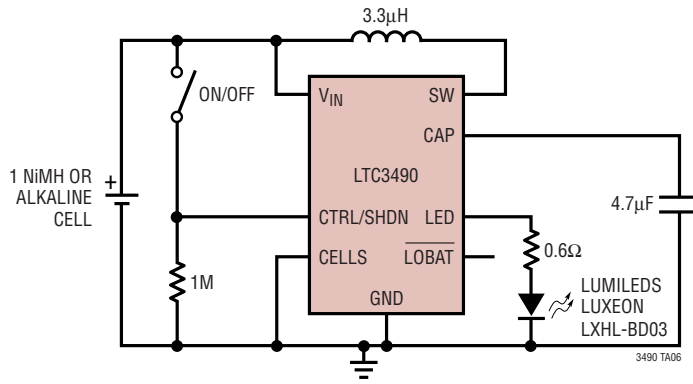

Luxeon Red LED Driver with Dimming

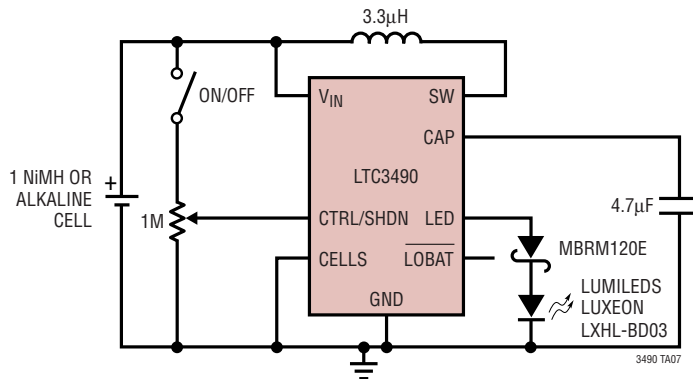

Efficiency vs V_{IN} with Red LED

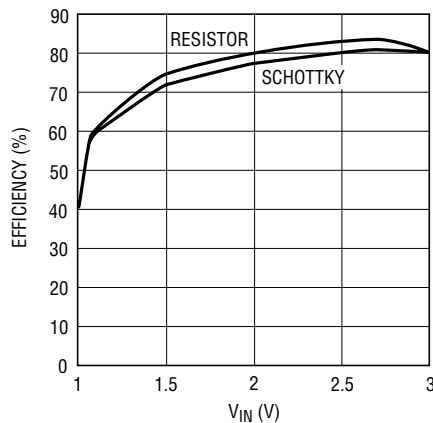

3490 G06

PACKAGE DESCRIPTION

DD Package 8-Lead Plastic DFN (3mm × 3mm) (Reference LTC DWG # 05-08-1698)

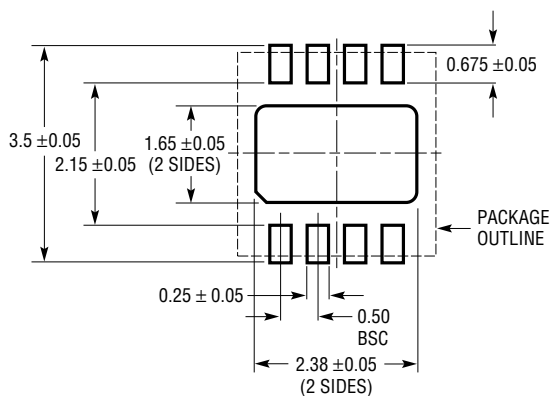

RECOMMENDED SOLDER PAD PITCH AND DIMENSIONS

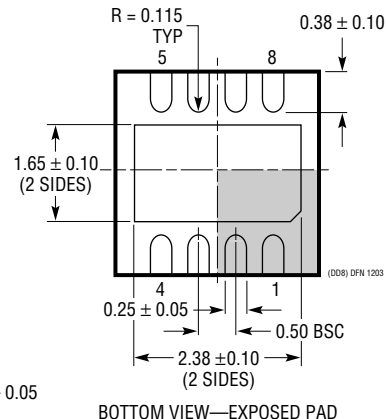
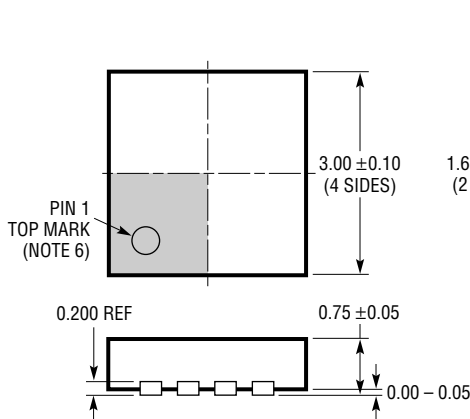

BOTTOM VIEW—EXPOSED PAD

NOTE:

1. DRAWING TO BE MADE A JEDEC PACKAGE OUTLINE M0-229 VARIATION OF (WEED-1)
2. DRAWING NOT TO SCALE
3. ALL DIMENSIONS ARE IN MILLIMETERS
4. DIMENSIONS OF EXPOSED PAD ON BOTTOM OF PACKAGE DO NOT INCLUDE MOLD FLASH. MOLD FLASH, IF PRESENT, SHALL NOT EXCEED 0.15mm ON ANY SIDE
5. EXPOSED PAD SHALL BE SOLDER PLATED
6. SHADED AREA IS ONLY A REFERENCE FOR PIN 1 LOCATION ON TOP AND BOTTOM OF PACKAGE

S8 Package 8-Lead Plastic Small Outline (Narrow .150 Inch) (Reference LTC DWG # 05-08-1610)

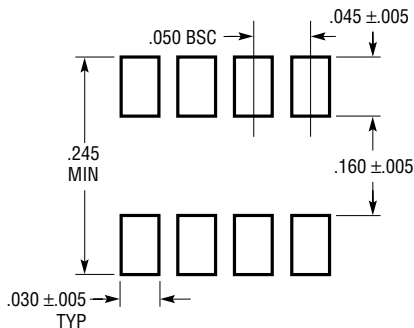

RECOMMENDED SOLDER PAD LAYOUT

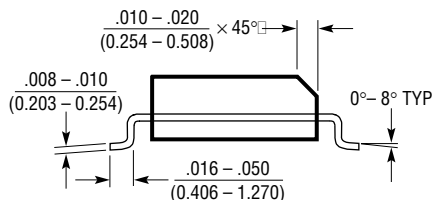
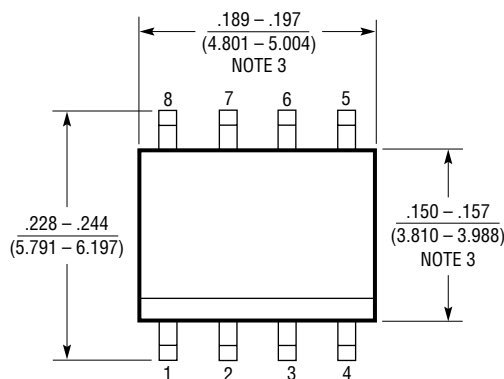

NOTE:

1. DIMENSIONS IN $\frac{\text{INCHES}}{\text{MILLIMETERS}}$
2. DRAWING NOT TO SCALE
3. THESE DIMENSIONS DO NOT INCLUDE MOLD FLASH OR PROTRUSIONS. MOLD FLASH OR PROTRUSIONS SHALL NOT EXCEED .006" (0.15mm)

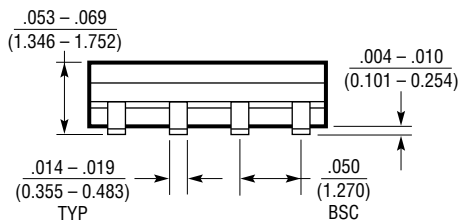

S08 0303

TYPICAL APPLICATION

LED Driver Drops to 20% Amplitude on Low-Battery Detect

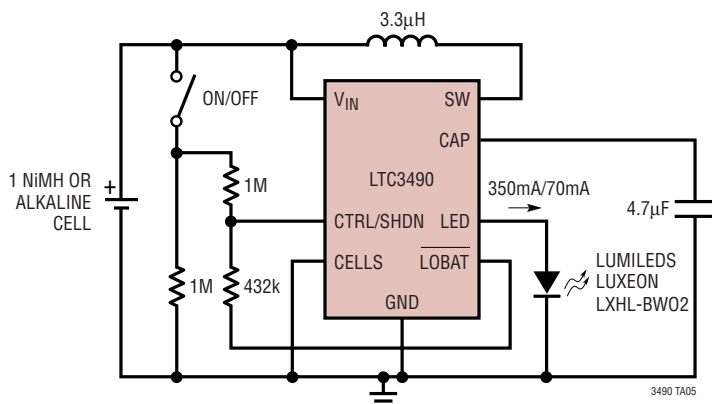

RELATED PARTS

PART NUMBER	DESCRIPTION	COMMENTS
LT [®] 1618	Constant Current, Constant Voltage 1.4MHz, High Efficiency Boost Regulator	V_{IN} : 1.6V to 18V, $V_{OUT(MAX)}$ = 34V, I_Q = 1.8mA, I_{SD} < 1µA, MS/EDD Packages
LT1932	Constant Current, 1.2MHz, High Efficiency White LED Boost Regulator	V_{IN} : 1V to 10V, $V_{OUT(MAX)}$ = 34V, I_Q = 1.2mA, I_{SD} < 1µA, ThinSOT Packages
LT1937	Constant Current, 1.2MHz, High Efficiency White LED Boost Regulator	V_{IN} : 2.5V to 10V, $V_{OUT(MAX)}$ = 34V, I_Q = 1.9mA, I_{SD} < 1µA, ThinSOT [™] /SC70 Packages
LTC3205	High Efficiency, Multi-Display LED Controller	V_{IN} : 2.8V to 4.5V, $V_{OUT(MAX)}$ = 6V, I_Q = 50µA, I_{SD} < 1µA, QFN24 Package
LTC3216	1A Low Noise, High Current LED Charge Pump with Independent Flash/Torch Current Control	V_{IN} : 2.9V to 4.4V, $V_{OUT(MAX)}$ = 5.5V, I_Q = 300µA, I_{SD} < 2.5µA, DFN Package
LTC3402	2A, 3MHz Micropower Synchronous Boost Converter	V_{IN} : 0.85V to 5V, $V_{OUT(MAX)}$ = 5V, I_Q = < 38µA, I_{SD} < 1µA, MS/EDD Packages
LTC3453	500mA Synchronous Buck-Boost High Current LED Driver in QFN	V_{IN} : 2.7V to 5.5V, $V_{OUT(MAX)}$ = 5.5V, I_Q = 0.6mA, I_{SD} < 6µA, QFN Package
LT3465/LT3465A	Constant Current, 1.2MHz/2.7MHz, High Efficiency White LED Boost Regulator with Integrated Schottky Diode	V_{IN} : 2.7V to 16V, $V_{OUT(MAX)}$ = 34V, I_Q = 1.9mA, I_{SD} < 1µA, ThinSOT Package
LT3466	Dual Constant Current, 2MHz, High Efficiency White LED Boost Regulator with Integrated Schottky Diode	V_{IN} : 2.7V to 24V, $V_{OUT(MAX)}$ = 40V, I_Q = 5mA, I_{SD} < 16µA, DFN Package
LT3479	3A, Full-Featured DC/DC Converter with Soft-Start and Inrush Current Protection	V_{IN} : 2.5V to 24V, $V_{OUT(MAX)}$ = 40V, I_Q = 6.5mA, I_{SD} < 1µA, DFN/TSSOP Packages

ThinSOT is a trademark of Linear Technology Corporation.

Looking for pricing, stock, or lifecycle information?

Click below to explore more details on WIN SOURCE:

 [View LTC3490EDD#TRPBF on WIN SOURCE](#)

 [Linear Technology](#) Information

Optimize Your Supply Chain with WIN SOURCE Solutions

-  Global Sourcing Solution
-  Obsolete Management
-  Cost Control Management
-  Shortage Management
-  Alternative Solution
-  Excess Inventory Management