



**THE DATASHEET OF
ADS7845E/2K5**





ADS7845

TOUCH SCREEN CONTROLLER

FEATURES

- 5-WIRE TOUCH SCREEN INTERFACE
- RATIOMETRIC CONVERSION
- SINGLE SUPPLY: 2V to 5V
- UP TO 125kHz CONVERSION RATE
- SERIAL INTERFACE
- PROGRAMMABLE 8- OR 12-BIT RESOLUTION
- AUXILIARY ANALOG INPUTS
- FULL POWER-DOWN CONTROL

APPLICATIONS

- PERSONAL DIGITAL ASSISTANTS
- PORTABLE INSTRUMENTS
- POINT-OF-SALES TERMINALS
- PAGERS
- TOUCH-SCREEN MONITORS

DESCRIPTION

The ADS7845 is a 12-bit sampling analog-to-digital converter (ADC) with a synchronous serial interface and low on-resistance switches for driving touch screens. Typical power dissipation is 750 μ W at a 125kHz throughput rate and a +2.7V supply. The reference voltage (V_{REF}) can be varied between 1V and + V_{CC} , providing a corresponding input voltage range of 0V to V_{REF} . The device includes a shutdown mode which reduces typical power dissipation to under 0.5 μ W. The ADS7845 is guaranteed down to 2.7V operation.

Low power, high speed, and on-board switches make the ADS7845 ideal for battery-operated systems such as personal digital assistants with resistive touch screens and other portable equipment. The ADS7845 is available in a 16-lead SSOP package and is guaranteed over the -40°C to +85°C temperature range.

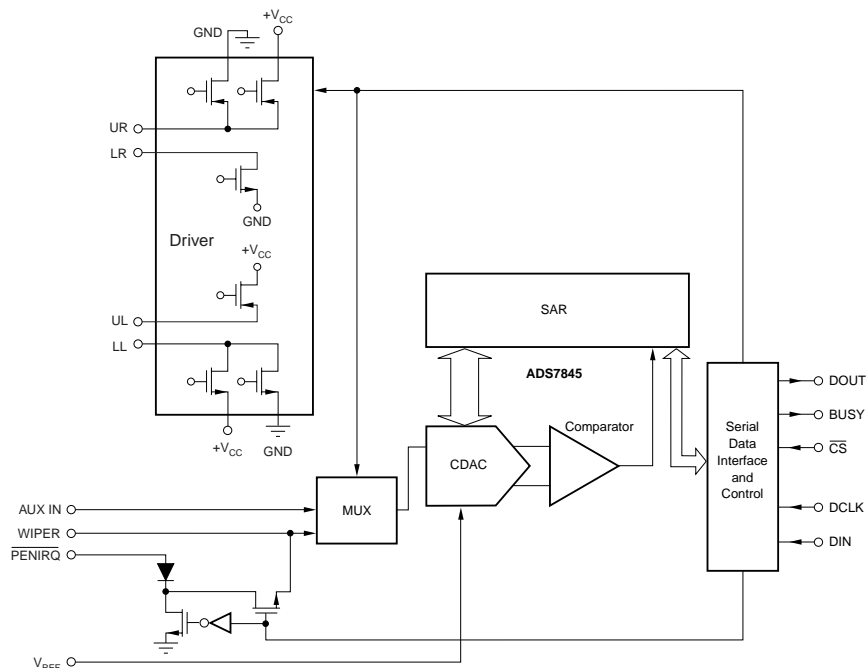

International Airport Industrial Park • Mailing Address: PO Box 11400, Tucson, AZ 85734 • Street Address: 6730 S. Tucson Blvd., Tucson, AZ 85706 • Tel: (520) 746-1111
Twx: 910-952-1111 • Internet: <http://www.burr-brown.com/> • Cable: BBRCORP • Telex: 066-6491 • FAX: (520) 889-1510 • Immediate Product Info: (800) 548-6132

SPECIFICATIONS

At $T_A = -40^\circ\text{C}$ to $+85^\circ\text{C}$, $+V_{CC} = +2.7\text{V}$, $V_{REF} = +2.5\text{V}$, $f_{SAMPLE} = 125\text{kHz}$, $f_{CLK} = 16 \cdot f_{SAMPLE} = 2\text{MHz}$, 12-bit mode, and digital inputs = GND or $+V_{CC}$, unless otherwise noted.

PARAMETER	CONDITIONS	ADS7845E			UNITS
		MIN	TYP	MAX	
RESOLUTION			12		Bits
ANALOG INPUT Full-Scale Input Span Absolute Input Range Capacitance Leakage Current	Positive Input - Negative Input Positive Input Negative Input	0 -0.2 -0.2		V_{REF} $+V_{CC} + 0.2$ $+0.2$	V V V pF μA
SYSTEM PERFORMANCE No Missing Codes Integral Linearity Error Offset Error Gain Error Noise Power Supply Rejection Ratio		11		± 2 ± 6 ± 4	Bits LSB ⁽¹⁾ LSB LSB μV_{rms} dB
SAMPLING DYNAMICS Conversion Time Acquisition Time Throughput Rate Multiplexer Settling Time Aperture Delay Aperture Jitter Channel-to-Channel Isolation	$V_{IN} = 2.5\text{V}_{p-p}$ at 50kHz	3		12 125	Clk Cycles Clk Cycles kHz ns ns ps dB
SWITCH DRIVERS On-Resistance UL, UR LL, LR			7 7		Ω Ω
REFERENCE INPUT Range Resistance Input Current	$\overline{CS} = \text{GND}$ or $+V_{CC}$ $f_{SAMPLE} = 12.5\text{kHz}$ $\overline{CS} = +V_{CC}$	1.0	5 13 2.5 0.001	$+V_{CC}$ 40 3	V G Ω μA μA μA
DIGITAL INPUT/OUTPUT Logic Family Logic Levels, Except \overline{PENIRQ} V_{IH} V_{IL} V_{OH} V_{OL} \overline{PENIRQ} V_{OL} Data Format	$ I_{IH} \leq +5\mu\text{A}$ $ I_{IL} \leq +5\mu\text{A}$ $I_{OH} = -250\mu\text{A}$ $I_{OL} = 250\mu\text{A}$ $T_A = 0^\circ\text{C}$ to $+85^\circ\text{C}$, 100k Ω Pull-Up	$+V_{CC} \cdot 0.7$ -0.3 $+V_{CC} \cdot 0.8$	CMOS	$+V_{CC} + 0.3$ $+0.8$ 0.4 0.8	V V V V
POWER SUPPLY REQUIREMENTS $+V_{CC}$ Quiescent Current Power Dissipation	Specified Performance ⁽²⁾ $f_{SAMPLE} = 12.5\text{kHz}$ Shutdown Mode with DCLK = DIN = $+V_{CC}$ $+V_{CC} = +2.7\text{V}$	2.7	280 220	5.5 650 3 1.8	V μA μA μA mW
TEMPERATURE RANGE Specified Performance		-40		+85	$^\circ\text{C}$

NOTE: (1) LSB means Least Significant Bit. With V_{REF} equal to $+2.5\text{V}$, one LSB is $610\mu\text{V}$. (2) ADS7845 will operate down to 2.0V .

The information provided herein is believed to be reliable; however, BURR-BROWN assumes no responsibility for inaccuracies or omissions. BURR-BROWN assumes no responsibility for the use of this information, and all use of such information shall be entirely at the user's own risk. Prices and specifications are subject to change without notice. No patent rights or licenses to any of the circuits described herein are implied or granted to any third party. BURR-BROWN does not authorize or warrant any BURR-BROWN product for use in life support devices and/or systems.

PIN CONFIGURATION

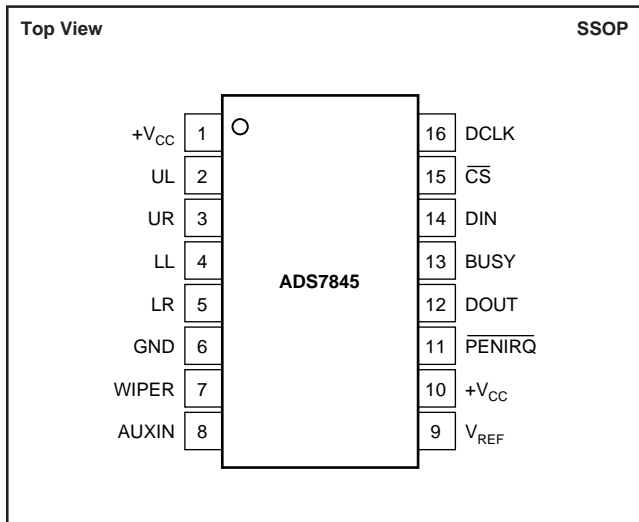

PIN DESCRIPTION

PIN	NAME	DESCRIPTION
1	+V _{CC}	Power Supply, 2.0V to 5V.
2	UL	Upper Left Panel Driver (V _{CC} ON/OFF)
3	UR	Upper Right Panel Driver (switch between V _{CC} and GND)
4	LL	Lower Left Panel Driver (switch between GND and V _{CC})
5	LR	Lower Right Panel Driver (GND ON/OFF)
6	GND	Ground
7	WIPER	Panel Input
8	AUXIN	Auxiliary Input
9	V _{REF}	Voltage Reference Input
10	+V _{CC}	Power Supply, 2.0V to 5V.
11	PENIRQ	Pen Interrupt. Open anode output (requires 10kΩ to 100kΩ pull-up resistor externally).
12	DOUT	Serial Data Output. Data is shifted on the falling edge of DCLK. This output is high impedance when CS is HIGH.
13	BUSY	Busy Output. This output is high impedance when CS is HIGH.
14	DIN	Serial Data Input. If CS is LOW, data is latched on rising edge of DCLK.
15	CS	Chip Select Input. Controls conversion timing and enables the serial input/output register.
16	DCLK	External Clock Input. This clock runs the SAR conversion process and synchronizes serial data I/O.

ABSOLUTE MAXIMUM RATINGS⁽¹⁾

+V _{CC} to GND	-0.3V to +6V
Analog Inputs to GND	-0.3V to +V _{CC} + 0.3V
Digital Inputs to GND	-0.3V to +V _{CC} + 0.3V
Power Dissipation	250mW
Maximum Junction Temperature	+150°C
Operating Temperature Range	-40°C to +85°C
Storage Temperature Range	-65°C to +150°C
Lead Temperature (soldering, 10s)	+300°C

NOTE: (1) Stresses above those listed under "Absolute Maximum Ratings" may cause permanent damage to the device. Exposure to absolute maximum conditions for extended periods may affect device reliability.



ELECTROSTATIC DISCHARGE SENSITIVITY

This integrated circuit can be damaged by ESD. Burr-Brown recommends that all integrated circuits be handled with appropriate precautions. Failure to observe proper handling and installation procedures can cause damage.

ESD damage can range from subtle performance degradation to complete device failure. Precision integrated circuits may be more susceptible to damage because very small parametric changes could cause the device not to meet its published specifications.

PACKAGE/ORDERING INFORMATION

PRODUCT	MAXIMUM INTEGRAL LINEARITY ERROR (LSB)	PACKAGE	PACKAGE DRAWING NUMBER ⁽¹⁾	SPECIFICATION TEMPERATURE RANGE	ORDERING NUMBER ⁽²⁾	TRANSPORT MEDIA
ADS7845E "	±2 "	16-Lead SSOP "	322 "	-40°C to +85°C "	ADS7845E ADS7845E/2K5	Rails Tape and Reel

NOTES: (1) For detailed drawing and dimension table, please see end of data sheet, or Appendix C of Burr-Brown IC Data Book. (2) Models with a slash (/) are available only in Tape and Reel in the quantities indicated (e.g., /2K5 indicates 2500 devices per reel). Ordering 2500 pieces of "ADS7845E/2K5" will get a single 2500-piece Tape and Reel. For detailed Tape and Reel mechanical information, refer to Appendix B of Burr-Brown IC Data Book.

TYPICAL PERFORMANCE CURVES

At $T_A = +25^\circ\text{C}$, $+V_{CC} = +2.7\text{V}$, $V_{REF} = +2.5\text{V}$, $f_{SAMPLE} = 125\text{kHz}$, and $f_{CLK} = 16 \cdot f_{SAMPLE} = 2\text{MHz}$, unless otherwise noted.

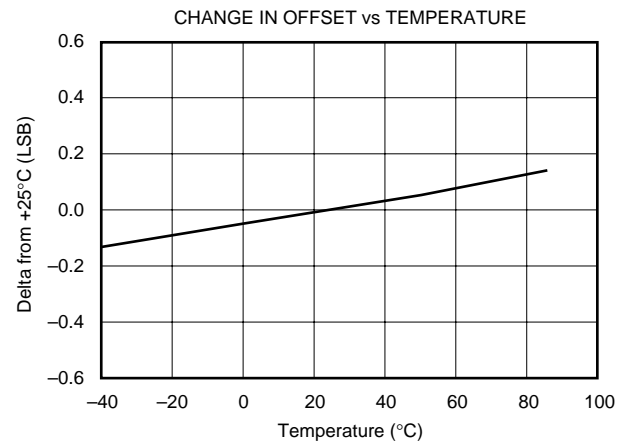
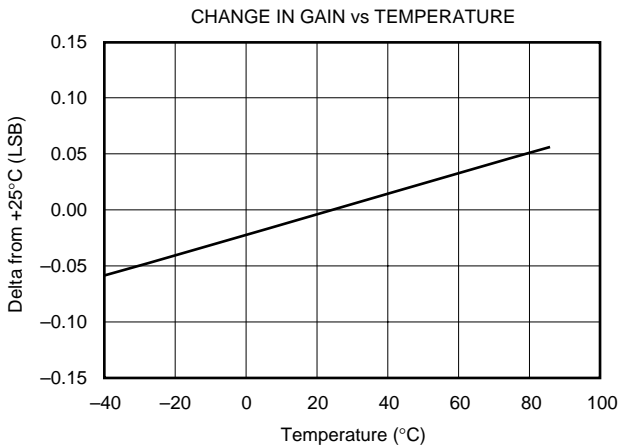
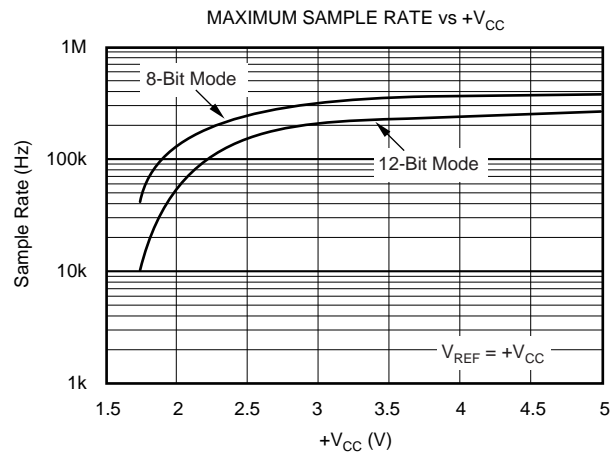
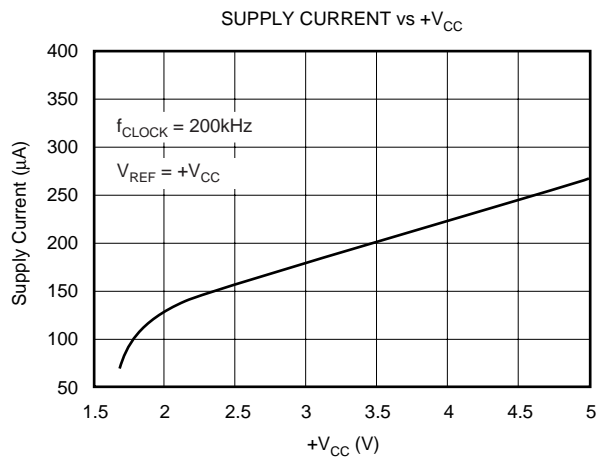
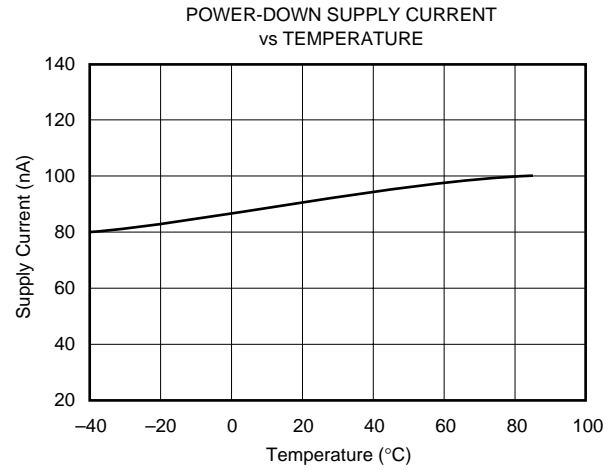
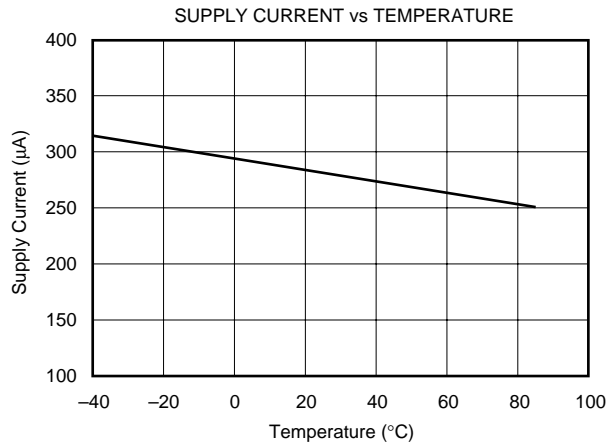

TYPICAL PERFORMANCE CURVES (CONT)

At $T_A = +25^\circ\text{C}$, $+V_{CC} = +2.7\text{V}$, $V_{REF} = +2.5\text{V}$, $f_{SAMPLE} = 125\text{kHz}$, and $f_{CLK} = 16 \cdot f_{SAMPLE} = 2\text{MHz}$, unless otherwise noted.

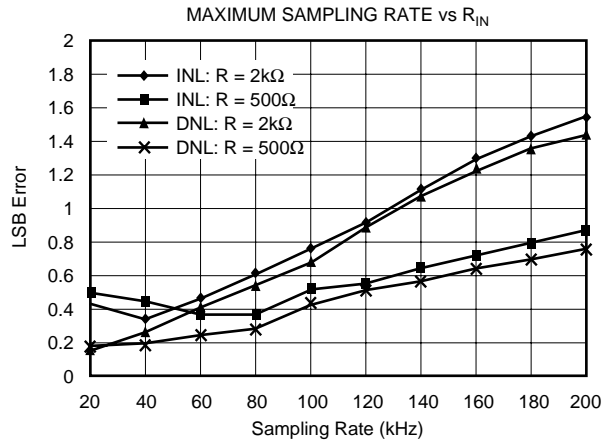
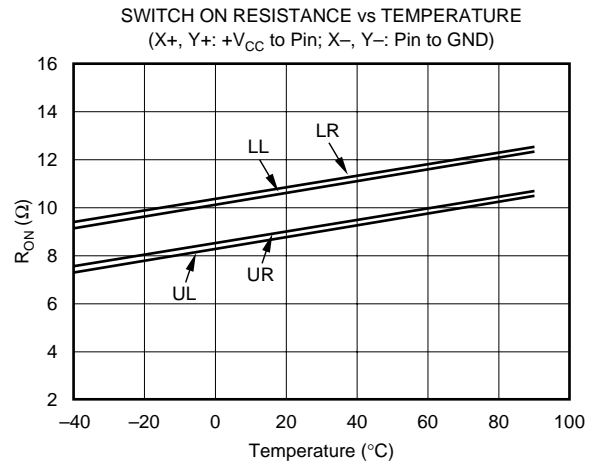
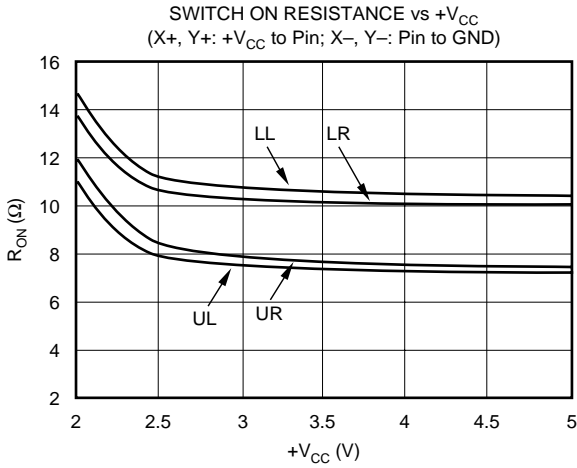
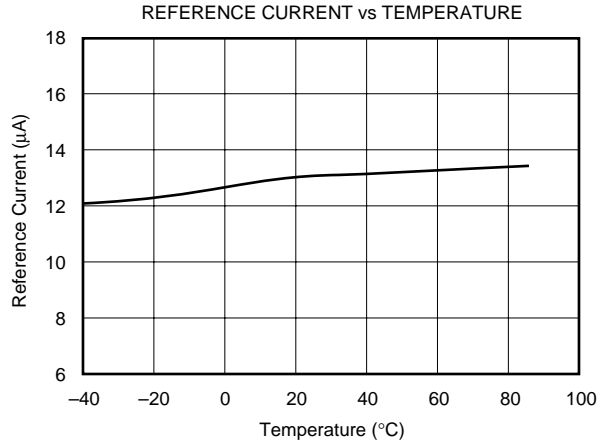
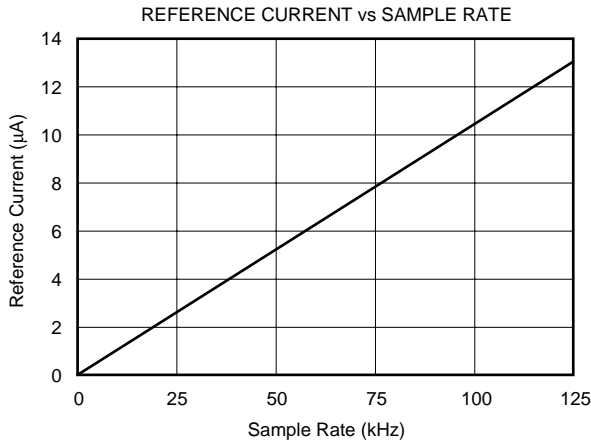

THEORY OF OPERATION

The ADS7845 is a classic Successive Approximation Register (SAR) analog-to-digital (A/D) converter. The architecture is based on capacitive redistribution which inherently includes a sample/hold function. The converter is fabricated on a 0.6μs CMOS process.

The basic operation of the ADS7845 is shown in Figure 1. The device requires an external reference and an external clock. It operates from a single supply of 2.0V to 5.25V. The external reference can be any voltage between 1V and +V_{CC}. The value of the reference voltage directly sets the input range of the converter. The average reference input current depends on the conversion rate of the ADS7845.

The analog input to the converter is provided via the WIPER input. In the measurement mode, the lower right corner of the panel is connected to GND and the upper left corner is connected to V_{CC}. When the lower left corner is connected to GND and the upper right corner is connected to V_{CC}, a “Y” measurement is made. When the lower left corner is connected to V_{CC} and the upper right corner is connected to GND, a “X” measurement is made. By maintaining a

differential input to the converter and a differential reference architecture, it is possible to negate the switch’s on-resistance error (should this be a source of error for the particular measurement).

ANALOG INPUT

Figure 2 shows a block diagram of the input multiplexer on the ADS7845, the differential input of the A/D converter, and the converter’s differential reference. Table I and Table II show the relationship between the A2, A1, A0, and SER/DFR control bits and the configuration of the ADS7845. The control bits are provided serially via the DIN pin—see the Digital Interface section of this data sheet for more details.

When the converter enters the hold mode, the voltage difference between the +IN and –IN inputs (see Figure 2) is captured on the internal capacitor array. The input current on the analog inputs depends on the conversion rate of the device. During the sample period, the source must charge the internal sampling capacitor (typically 25pF). After the capacitor has been fully charged, there is no further input current. The rate of charge transfer from the analog source to the converter is a function of conversion rate.

A2	A1	A0	DRV1	DRV2	AUXIN	INTERRUPT	–IN ⁽¹⁾	X POSITION	Y POSITION	+REF ⁽¹⁾	–REF ⁽¹⁾
0	0	1	ON				GND	OFF	ON	+V _{REF}	GND
1	0	1		ON			GND	ON	OFF	+V _{REF}	GND
0	1	0			ON		GND	OFF	OFF	+V _{REF}	GND
1	1	0				DOUT	GND	OFF	OFF	+V _{REF}	GND

NOTE: (1) Internal node, for clarification only—not directly accessible by the user.

TABLE I. Input Configuration—Single-Ended Reference Mode (SER/DFR HIGH).

A2	A1	A0	DRV1	DRV2	AUXIN	INTERRUPT	–IN ⁽¹⁾	X SWITCHES	Y SWITCHES	+REF ⁽¹⁾	–REF ⁽¹⁾
0	0	1	ON				LR	OFF	ON	UL	LR
1	0	1		ON			LR	ON	OFF	UL	LR
0	1	0			ON		GND	OFF	OFF	+V _{REF}	GND
1	1	0				DOUT	GND	OFF	OFF	+V _{REF}	GND

NOTE: (1) Internal node, for clarification only—not directly accessible by the user.

TABLE II. Input Configuration—Differential Reference Mode (SER/DFR LOW).

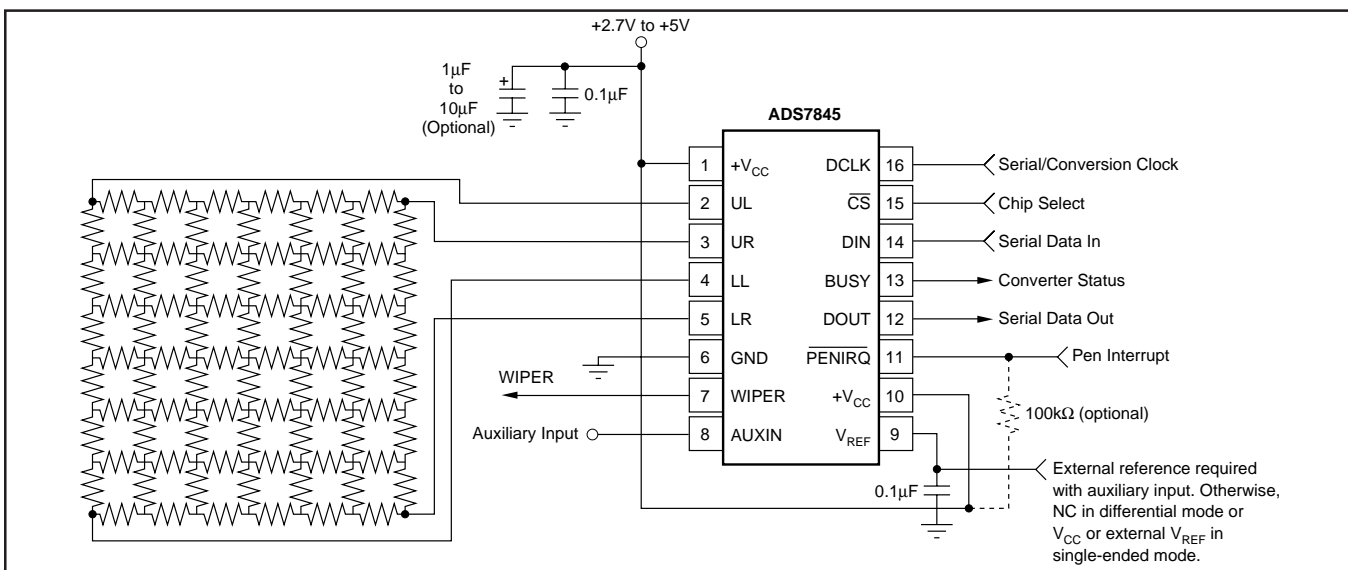

FIGURE 1. Basic Operation of the ADS7845.

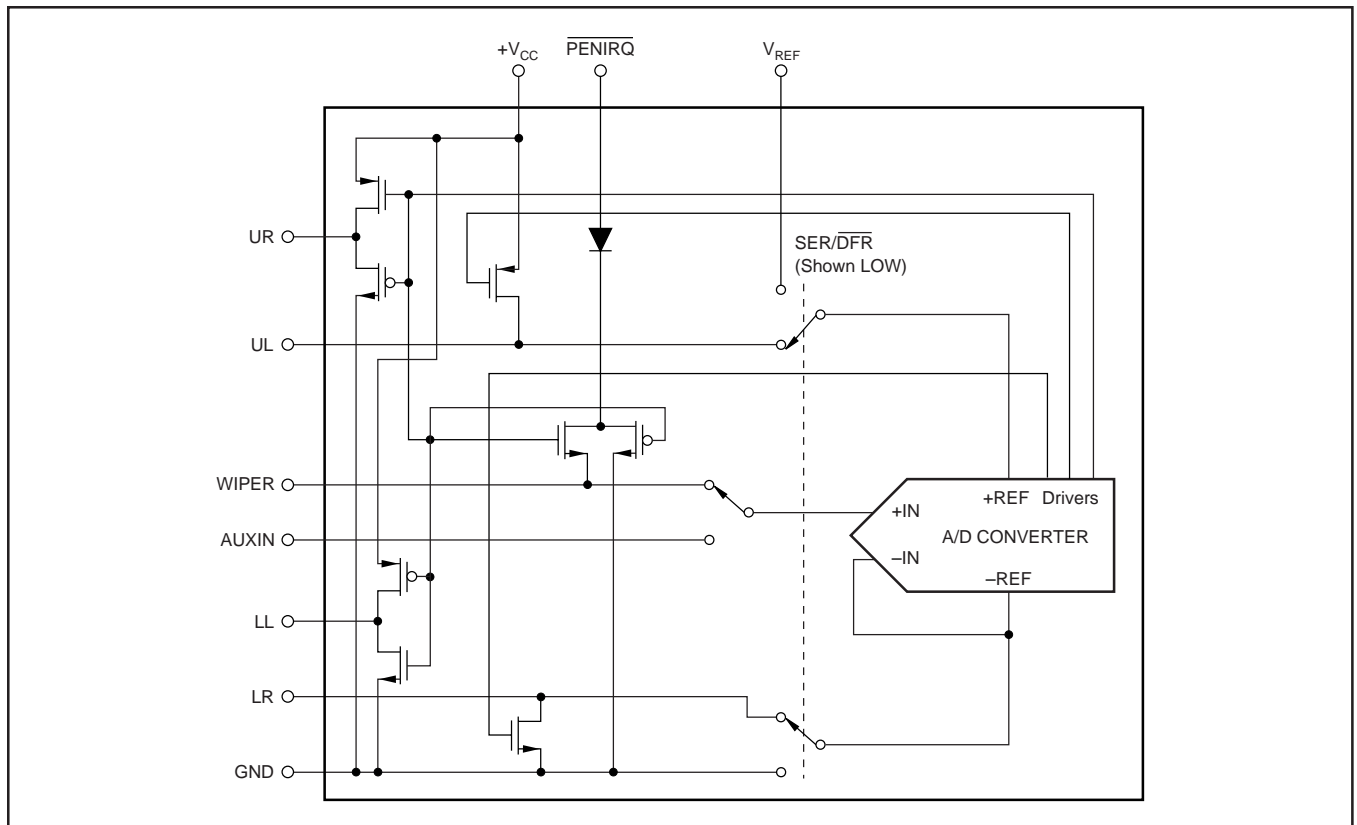

FIGURE 2. Simplified Diagram of ADS7845 Input and Panel Drivers.

REFERENCE INPUT

The voltage difference between +REF and -REF (see Figure 2) sets the analog input range. The ADS7845 will operate with a reference in the range of 1V to $+V_{CC}$. There are several critical items concerning the reference input and its wide voltage range. As the reference voltage is reduced, the analog voltage weight of each digital output code is also reduced. This is often referred to as the Least Significant Bit (LSB) size and is equal to the reference voltage divided by 4096. Any offset or gain error inherent in the A/D converter will appear to increase, in terms of LSB size, as the reference voltage is reduced. For example, if the offset of a given converter is 2 LSBs with a 2.5V reference, it will typically be 5 LSBs with a 1V reference. In each case, the actual offset of the device is the same, 1.22mV. With a lower reference voltage, more care must be taken to provide a clean layout including adequate bypassing, a clean (low noise, low ripple) power supply, a low-noise reference, and a low-noise input signal.

The voltage into the V_{REF} input is not buffered and directly drives the capacitor digital-to-analog converter (CDAC) portion of the ADS7845. Typically, the input current is 13 μ A with $V_{REF} = 2.5V$ and $f_{SAMPLE} = 125kHz$. This value will vary by a few microamps depending on the result of the conversion. The reference current diminishes directly with both conversion rate and reference voltage. As the current from the reference is drawn on each bit decision, clocking the converter more quickly during a given conversion period will not reduce overall current drain from the reference.

There is also a critical item regarding the reference when making measurements where the switch drivers are on. For this discussion, it's useful to consider the basic operation of the ADS7845 as shown in Figure 1. This particular application shows the device being used to digitize a resistive touch screen. A measurement of the current Y position of the pointing device is made with the WIPER input to the A/D converter, turning on the UL and UR drivers to V_{CC} , grounding LL and LR, and digitizing the voltage on the WIPER (see Figure 3 for a block diagram).

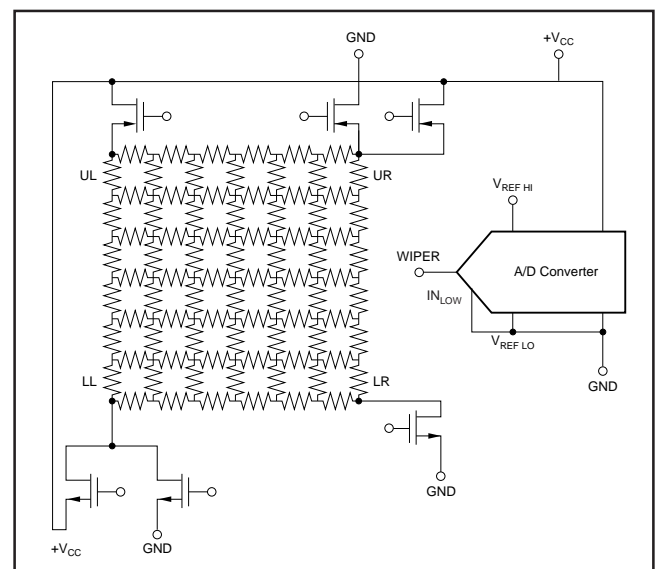

FIGURE 3. Simplified Diagram of Single-Ended Reference (SER/DFR HIGH).

Under the situation outlined so far, it would not be possible to achieve a zero volt input or a full-scale input regardless of where the pointing device is on the touch screen because some voltage is lost across the internal switches. In addition, the internal switch resistance is unlikely to track the resistance of the touch screen, providing an additional source of error.

This situation can be remedied as shown in Figure 4. By setting the $\overline{\text{SER/DFR}}$ bit LOW, the +REF and -REF inputs are connected directly to Y+ and Y-. This makes the analog-to-digital conversion ratiometric. The result of the conversion is always a percentage of the external resistance, regardless of how it changes in relation to the on-resistance of the internal switches. NOTE: There is an important consideration regarding power dissipation when using the ratiometric mode of operation. See the Power Dissipation section for more details.

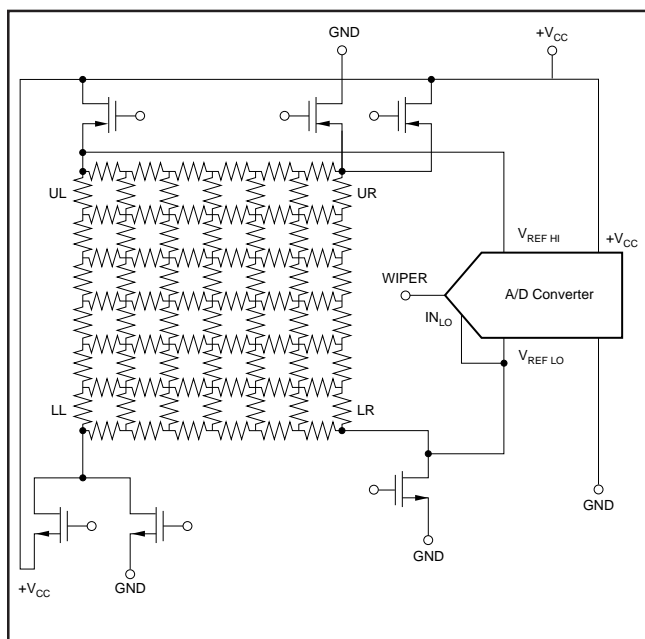

FIGURE 4. Simplified Diagram of Differential Reference ($\overline{\text{SER/DFR}}$ LOW).

As a final note about the differential reference mode, it must be used with $+V_{CC}$ as the source of the +REF voltage and cannot be used with V_{REF} . It is possible to use a high precision reference on V_{REF} and single-ended reference mode for measurements which do not need to be ratiometric. Or, in some cases, it could be possible to power the converter directly from a precision reference. Most references can provide enough power for the ADS7845, but they might not be able to supply enough current for the external load (such as a resistive touch screen).

DIGITAL INTERFACE

Figure 5 shows the typical operation of the ADS7845's digital interface. This diagram assumes that the source of the digital signals is a microcontroller or digital signal processor with a basic serial interface. Each communication between the

processor and the converter consists of 8 clock cycles. One complete conversion can be accomplished with three serial communications, for a total of 24 clock cycles on the DCLK input.

The first 8 clock cycles are used to provide the control byte via the DIN pin. When the converter has enough information about the following conversion to set the input multiplexer, switches, and reference inputs appropriately, the converter enters the acquisition (sample) mode and, if needed, the internal switches are turned on. After three more clock cycles, the control byte is complete and the converter enters the conversion mode. At this point, the input sample/hold goes into the hold mode and the internal switches may turn off. The next 12 clock cycles accomplish the actual analog-to-digital conversion. If the conversion is ratiometric ($\overline{\text{SER/DFR}}$ LOW), the internal switches are on during the conversion. A 13th clock cycle is needed for the last bit of the conversion result. Three more clock cycles are needed to complete the last byte (DOUT will be LOW). These will be ignored by the converter.

Control Byte

Also shown in Figure 5 is the placement and order of the control bits within the control byte. Tables III and IV give detailed information about these bits. The first bit, the 'S' bit, must always be HIGH and indicates the start of the control byte. The ADS7845 will ignore inputs on the DIN pin until the start bit is detected. The next three bits (A2 - A0) select the active panel drivers (see Tables I and II and Figure 2). The MODE bit determines the number of bits for each conversion, either 12 bits (LOW) or 8 bits (HIGH).

The $\overline{\text{SER/DFR}}$ bit controls the reference mode: either single-ended (HIGH) or differential (LOW). (The differential mode is also referred to as the ratiometric conversion mode.) In

BIT 7 (MSB)	BIT 6	BIT 5	BIT 4	BIT 3	BIT 2	BIT 1	BIT 0 (LSB)
S	A2	A1	A0	MODE	$\overline{\text{SER/DFR}}$	PD1	PD0

TABLE III. Order of the Control Bits in the Control Byte.

BIT	NAME	DESCRIPTION
7	S	Start Bit. Control byte starts with first HIGH bit on DIN. A new control byte can start every 15th clock cycle in 12-bit conversion mode or every 11th clock cycle in 8-bit conversion mode.
6 - 4	A2 - A0	Channel Select Bits. Along with the $\overline{\text{SER/DFR}}$ bit, these bits control the setting of the multiplexer input, switches, and reference inputs, as detailed in Tables I and II.
3	MODE	12-Bit/8-Bit Conversion Select Bit. This bit controls the number of bits for the following conversion: 12 bits (LOW) or 8 bits (HIGH).
2	$\overline{\text{SER/DFR}}$	Single-Ended/Differential Reference Select Bit. Along with bits A2 - A0, this bit controls the setting of the multiplexer input, switches, and reference inputs, as detailed in Tables I and II.
1 - 0	PD1 - PD0	Power-Down Mode Select Bits. See Table V for details.

TABLE IV. Descriptions of the Control Bits within the Control Byte.

single-ended mode, the converter's reference voltage is always the difference between the V_{REF} and GND pins. In differential mode, the reference voltage is the difference between the currently enabled switches. See Tables I and II and Figures 2 through 4 for more information. The last two bits (PD1 - PD0) select the power-down mode as shown in Table V. If both inputs are HIGH, the device is always powered up. If both inputs are LOW, the device enters a power-down mode between conversions. When a new conversion is initiated, the device will resume normal operation instantly—no delay is needed to allow the device to power up and the very first conversion will be valid. There are two power-down modes: one where \overline{PENIRQ} is disabled and one where it is enabled.

PD1	PD0	\overline{PENIRQ}	DESCRIPTION
0	0	Enabled	Power-down between conversions. When each conversion is finished, the converter enters a LOW power mode. At the start of the next conversion, the device instantly powers up to full power. There is no need for additional delays to assure full operation and the very first conversion is valid. The LR- switch is on while in power-down.
0	1	Disabled	Same as mode 00, except \overline{PENIRQ} is disabled. The LR- switch is off while in power-down mode.
1	0	Disabled	Reserved for future use.
1	1	Disabled	No power down between conversions, device is always powered.

TABLE V. Power-Down Selection.

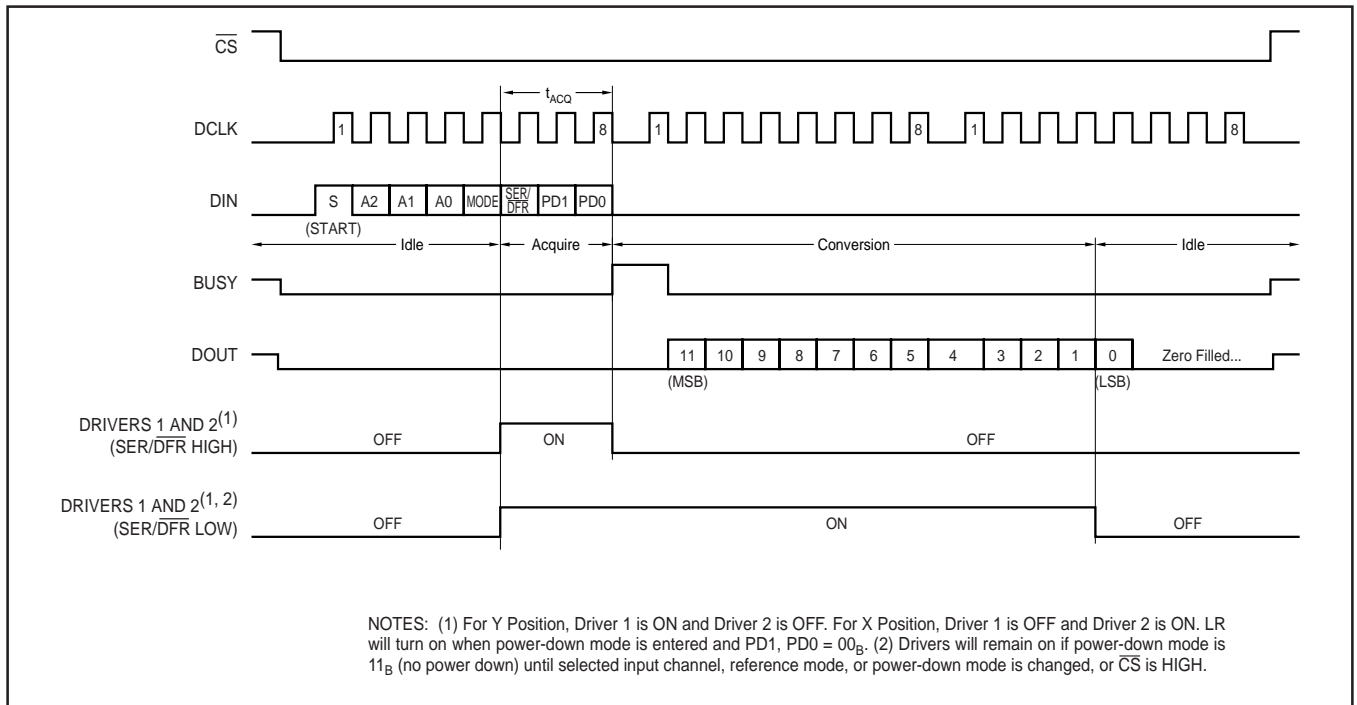

FIGURE 5. Conversion Timing, 24 Clocks per Conversion, 8-Bit Bus Interface. No DCLK Delay Required with Dedicated Serial Port.

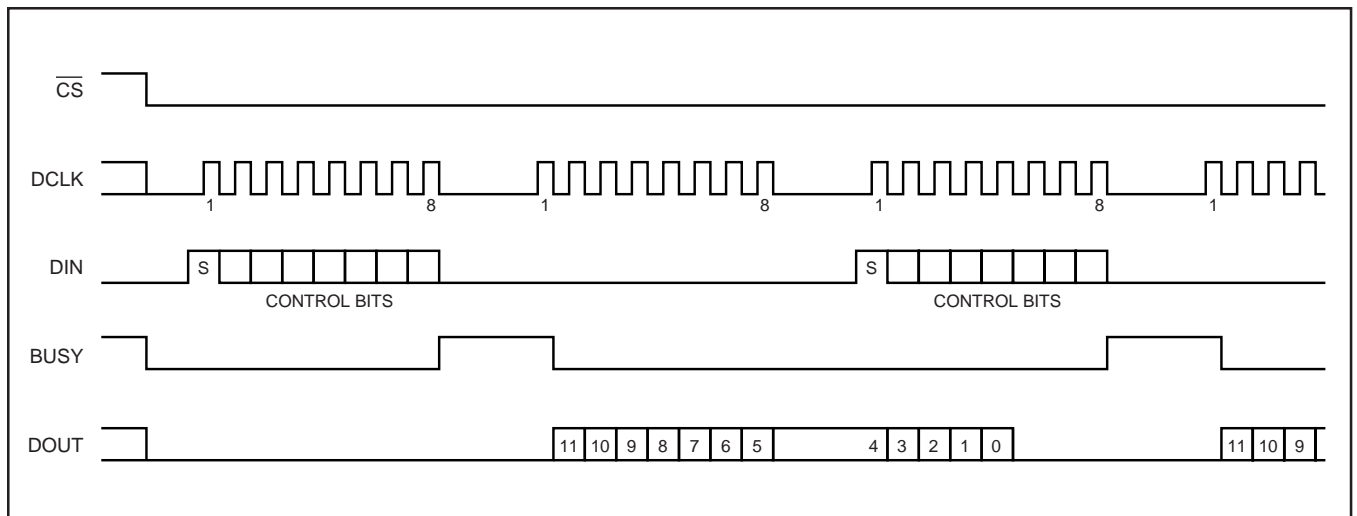

FIGURE 6. Conversion Timing, 16 Clocks per Conversion, 8-Bit Bus Interface. No DCLK Delay Required with Dedicated Serial Port.

16 Clocks per Conversion

The control bits for conversion n+1 can be overlapped with conversion 'n' to allow for a conversion every 16 clock cycles, as shown in Figure 6. This figure also shows possible serial communication occurring with other serial peripherals between each byte transfer between the processor and the converter. This is possible provided that each conversion completes within 1.6ms of starting. Otherwise, the signal that has been captured on the input sample/hold may droop enough to affect the conversion result. Note that the ADS7845 is fully powered while other serial communications are taking place during a conversion.

Digital Timing

Figure 7 and Table VI provide detailed timing for the digital interface of the ADS7845.

15 Clocks per Conversion

Figure 8 provides the fastest way to clock the ADS7845. This method will not work with the serial interface of most microcontrollers and digital signal processors as they are generally not capable of providing 15 clock cycles per serial transfer. However, this method could be used with Field

Programmable Gate Arrays (FPGAs) or Application Specific Integrated Circuits (ASICs). This effectively increases the maximum conversion rate of the converter beyond the values given in the Specification table, which assume 16 clock cycles per conversion.

SYMBOL	DESCRIPTION	MIN	TYP	MAX	UNITS
t_{ACQ}	Acquisition Time	1.5			μ s
t_{DS}	DIN Valid Prior to DCLK Rising	100			ns
t_{DH}	DIN Hold After DCLK HIGH	10			ns
t_{DO}	DCLK Falling to DOUT Valid			200	ns
t_{DV}	\overline{CS} Falling to DOUT Enabled			200	ns
t_{TR}	\overline{CS} Rising to DOUT Disabled			200	ns
t_{CSS}	\overline{CS} Falling to First DCLK Rising	100			ns
t_{CSH}	\overline{CS} Rising to DCLK Ignored	0			ns
t_{CH}	DCLK HIGH	200			ns
t_{CL}	DCLK LOW	200			ns
t_{BD}	DCLK Falling to BUSY Rising			200	ns
t_{BDV}	\overline{CS} Falling to BUSY Enabled			200	ns
t_{BTR}	\overline{CS} Rising to BUSY Disabled			200	ns

TABLE VI. Timing Specifications (+V_{CC} = +2.7V and Above, T_A = -40°C to +85°C, C_{LOAD} = 50pF).

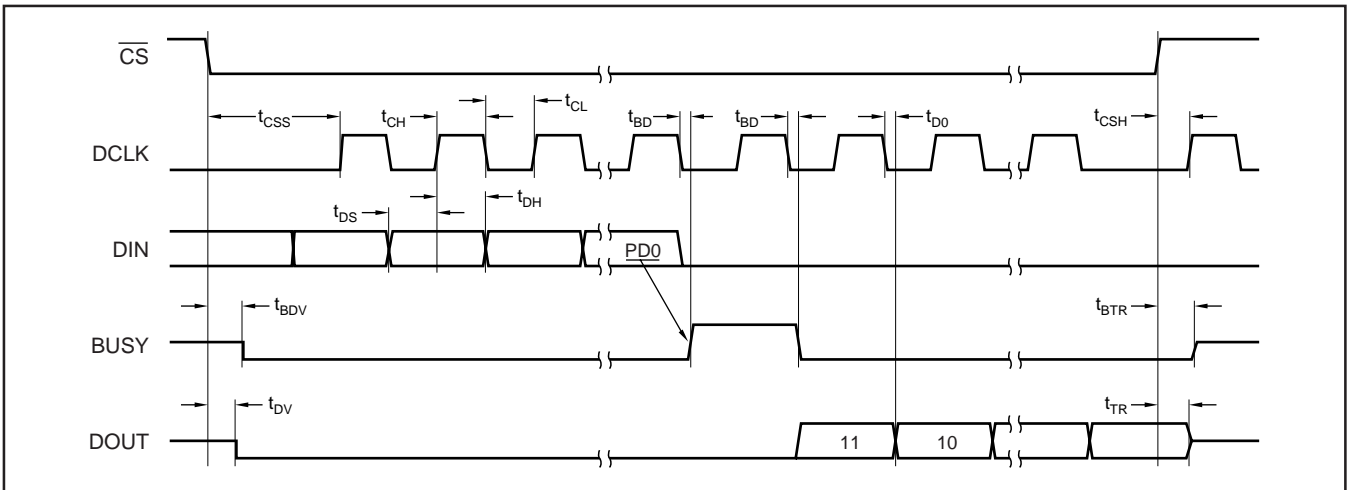

FIGURE 7. Detailed Timing Diagram.

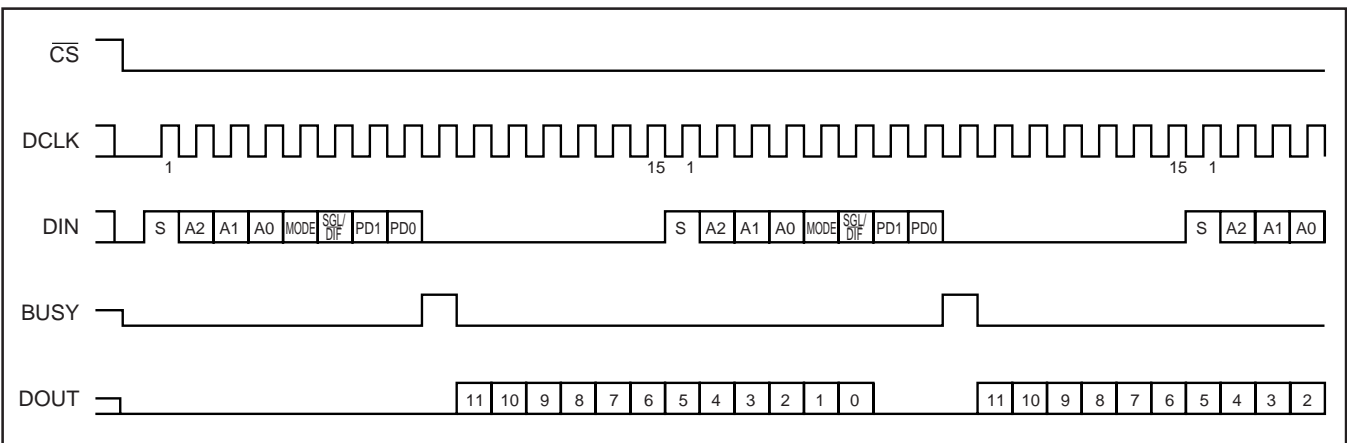

FIGURE 8. Maximum Conversion Rate, 15 Clocks per Conversion.

Data Format

The ADS7845 output data is in Straight Binary format as shown in Figure 9. This figure shows the ideal output code for the given input voltage and does not include the effects of offset, gain, or noise.

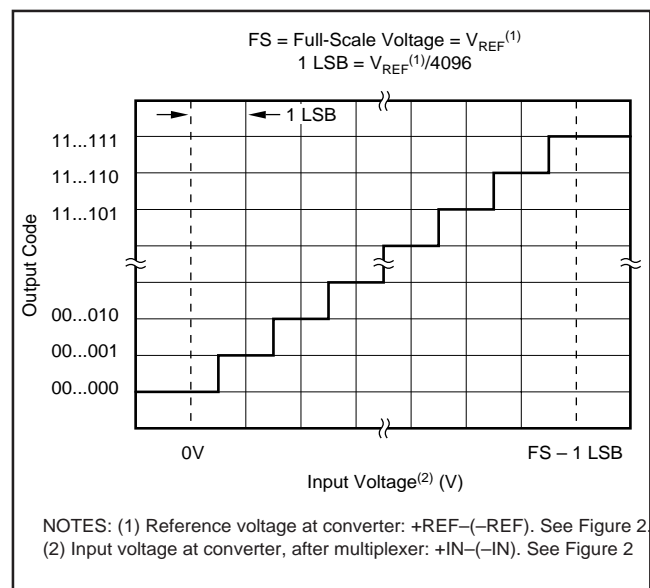

FIGURE 9. Ideal Input Voltages and Output Codes.

8-Bit Conversion

The ADS7845 provides an 8-bit conversion mode that can be used when faster throughput is needed and the digital result is not as critical. By switching to the 8-bit mode, a conversion is complete four clock cycles earlier. This could be used in conjunction with serial interfaces that provide 12-bit transfers or two conversions could be accomplished with three 8-bit transfers. Not only does this shorten each conversion by four bits (25% faster throughput), but each conversion can actually occur at a faster clock rate. This is because the internal settling time of the ADS7845 is not as critical—settling to better than 8 bits is all that is needed. The clock rate can be as much as 50% faster. The faster clock rate and fewer clock cycles combine to provide a 2x increase in conversion rate.

POWER DISSIPATION

There are two major power modes for the ADS7845: full power (PD1 - PD0 = 11_B) and auto power-down (PD1 - PD0 = 00_B). When operating at full speed and 16-clocks per conversion (as shown in Figure 6), the ADS7845 spends most of its time acquiring or converting. There is little time for auto power-down, assuming that this mode is active. Therefore, the difference between full power mode and auto power-down is negligible. If the conversion rate is decreased by simply slowing the frequency of the DCLK input, the two modes remain approximately equal. However, if the DCLK frequency is kept at the maximum rate during a conversion but conversions are simply done less often, the difference between the two modes is dramatic.

Figure 10 shows the difference between reducing the DCLK frequency (“scaling” DCLK to match the conversion rate) or maintaining DCLK at the highest frequency and reducing the number of conversions per second. In the later case, the converter spends an increasing percentage of its time in power-down mode (assuming the auto power-down mode is active).

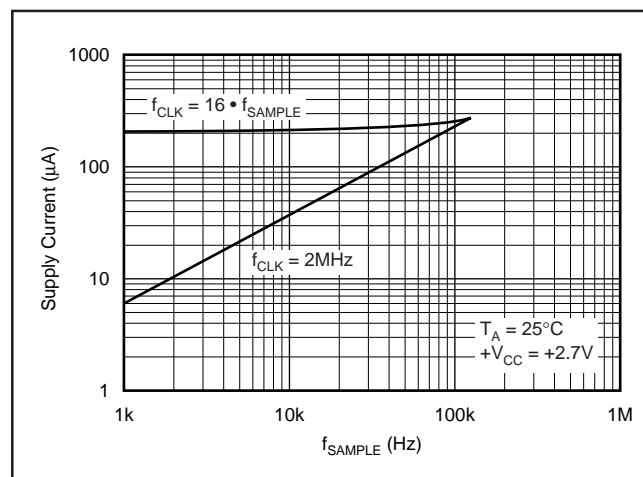

FIGURE 10. Supply Current vs Directly Scaling the Frequency of DCLK with Sample Rate or Keeping DCLK at the Maximum Possible Frequency.

Another important consideration for power dissipation is the reference mode of the converter. In the single-ended reference mode, the converter’s internal switches are on only when the analog input voltage is being acquired (see Figure 5). Thus, the external device, such as a resistive touch screen, is only powered during the acquisition period. In the differential reference mode, the external device must be powered throughout the acquisition and conversion periods (see Figure 5). If the conversion rate is high, this could substantially increase power dissipation.

LAYOUT

The following layout suggestions should provide the most optimum performance from the ADS7845. However, many portable applications have conflicting requirements concerning power, cost, size, and weight. In general, most portable devices have fairly “clean” power and grounds because most of the internal components are very low power. This situation would mean less bypassing for the converter’s power and less concern regarding grounding. Still, each situation is unique and the following suggestions should be reviewed carefully.

For optimum performance, care should be taken with the physical layout of the ADS7845 circuitry. The basic SAR architecture is sensitive to glitches or sudden changes on the power supply, reference, ground connections, and digital inputs that occur just prior to latching the output of the analog comparator. Thus, during any single conversion for an ‘n-bit’ SAR converter, there are n ‘windows’ in which

large external transient voltages can easily affect the conversion result. Such glitches might originate from switching power supplies, nearby digital logic, and high power devices. The degree of error in the digital output depends on the reference voltage, layout, and the exact timing of the external event. The error can change if the external event changes in time with respect to the DCLK input.

With this in mind, power to the ADS7845 should be clean and well bypassed. A 0.1 μ F ceramic bypass capacitor should be placed as close to the device as possible. A 1 μ F to 10 μ F capacitor may also be needed if the impedance of the connection between +V_{CC} and the power supply is high.

The reference should be similarly bypassed with a 0.1 μ F capacitor. If the reference voltage originates from an op amp, make sure that it can drive the bypass capacitor without oscillation. The ADS7845 draws very little current from the reference on average, but it does place larger demands on the reference circuitry over short periods of time (on each rising edge of DCLK during a conversion).

The ADS7845 architecture offers no inherent rejection of noise or voltage variation in regards to the reference input. This is of particular concern when the reference input is tied to the power supply. Any noise and ripple from the supply will appear directly in the digital results. While high frequency noise can be filtered out, voltage variation due to line frequency (50Hz or 60Hz) can be difficult to remove.

The GND pin should be connected to a clean ground point. In many cases, this will be the “analog” ground. Avoid connections which are too near the grounding point of a microcontroller or digital signal processor. If needed, run a ground trace directly from the converter to the power supply entry or battery connection point. The ideal layout will include an analog ground plane dedicated to the converter and associated analog circuitry.

In the specific case of use with a resistive touch screen, care should be taken with the connection between the converter and the touch screen. Since resistive touch screens have fairly low resistance, the interconnection should be as short and robust as possible. Longer connections will be a source of error, much like the on-resistance of the internal switches. Likewise, loose connections can be a source of error when the contact resistance changes with flexing or vibrations.

PENIRQ Output

The pen interrupt output function is detailed in Figure 11. By connecting a pull-up resistor to V_{CC} (typically 100k Ω), the $\overline{\text{PENIRQ}}$ output is HIGH. While in the power-down mode, with PD0 = PD1 = 0, the lower-right panel corner is connected to GND and the $\overline{\text{PENIRQ}}$ output is connected to the WIPER input. When the panel is touched, the $\overline{\text{PENIRQ}}$ output goes LOW, due to the current path through the panel to GND, initiating an interrupt to the processor. During the measurement cycles for X and Y position, the $\overline{\text{PENIRQ}}$ output diode will be internally connected to GND and the WIPER disconnected from the $\overline{\text{PENIRQ}}$ diode to eliminate any leakage current from the pull-up resistor to flow through the WIPER, thus causing no errors.

In addition, when the DIN has selected A2 = 1, A1 = 1, A0 = 0, and the ADS7845 is commanded into the power-down mode (PD0 and PD1 = 0) and $\overline{\text{CS}}$ is LOW (when $\overline{\text{CS}}$ is HI, the DOUT line is high impedance), the DOUT will be LOW (all “0”s) during no touch and HI (all “1”s) when the panel is touched. This feature eliminates the need for an additional port to detect panel touch. Since all panels have end resistance, all “0”s and all “1”s are an unused set of codes.

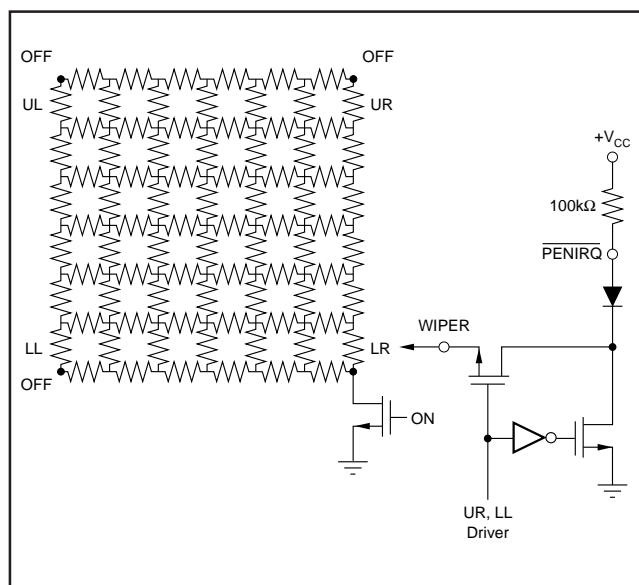

FIGURE 11. $\overline{\text{PENIRQ}}$ Functional Block Diagram.

PACKAGING INFORMATION

Orderable Device	Status ⁽¹⁾	Package Type	Package Drawing	Pins	Package Qty	Eco Plan ⁽²⁾	Lead/Ball Finish	MSL Peak Temp ⁽³⁾
ADS7845E	ACTIVE	SSOP/ QSOP	DBQ	16	75	Green (RoHS & no Sb/Br)	CU NIPDAU	Level-2-260C-1 YEAR
ADS7845E/2K5	ACTIVE	SSOP/ QSOP	DBQ	16	2500	Green (RoHS & no Sb/Br)	CU NIPDAU	Level-2-260C-1 YEAR
ADS7845E/2K5G4	ACTIVE	SSOP/ QSOP	DBQ	16	2500	Green (RoHS & no Sb/Br)	CU NIPDAU	Level-2-260C-1 YEAR
ADS7845EG4	ACTIVE	SSOP/ QSOP	DBQ	16	75	Green (RoHS & no Sb/Br)	CU NIPDAU	Level-2-260C-1 YEAR

⁽¹⁾ The marketing status values are defined as follows:

ACTIVE: Product device recommended for new designs.

LIFEBUY: TI has announced that the device will be discontinued, and a lifetime-buy period is in effect.

NRND: Not recommended for new designs. Device is in production to support existing customers, but TI does not recommend using this part in a new design.

PREVIEW: Device has been announced but is not in production. Samples may or may not be available.

OBSOLETE: TI has discontinued the production of the device.

⁽²⁾ Eco Plan - The planned eco-friendly classification: Pb-Free (RoHS), Pb-Free (RoHS Exempt), or Green (RoHS & no Sb/Br) - please check <http://www.ti.com/productcontent> for the latest availability information and additional product content details.

TBD: The Pb-Free/Green conversion plan has not been defined.

Pb-Free (RoHS): TI's terms "Lead-Free" or "Pb-Free" mean semiconductor products that are compatible with the current RoHS requirements for all 6 substances, including the requirement that lead not exceed 0.1% by weight in homogeneous materials. Where designed to be soldered at high temperatures, TI Pb-Free products are suitable for use in specified lead-free processes.

Pb-Free (RoHS Exempt): This component has a RoHS exemption for either 1) lead-based flip-chip solder bumps used between the die and package, or 2) lead-based die adhesive used between the die and leadframe. The component is otherwise considered Pb-Free (RoHS compatible) as defined above.

Green (RoHS & no Sb/Br): TI defines "Green" to mean Pb-Free (RoHS compatible), and free of Bromine (Br) and Antimony (Sb) based flame retardants (Br or Sb do not exceed 0.1% by weight in homogeneous material)

⁽³⁾ MSL, Peak Temp. -- The Moisture Sensitivity Level rating according to the JEDEC industry standard classifications, and peak solder temperature.

Important Information and Disclaimer:The information provided on this page represents TI's knowledge and belief as of the date that it is provided. TI bases its knowledge and belief on information provided by third parties, and makes no representation or warranty as to the accuracy of such information. Efforts are underway to better integrate information from third parties. TI has taken and continues to take reasonable steps to provide representative and accurate information but may not have conducted destructive testing or chemical analysis on incoming materials and chemicals. TI and TI suppliers consider certain information to be proprietary, and thus CAS numbers and other limited information may not be available for release.

In no event shall TI's liability arising out of such information exceed the total purchase price of the TI part(s) at issue in this document sold by TI to Customer on an annual basis.

TAPE AND REEL INFORMATION

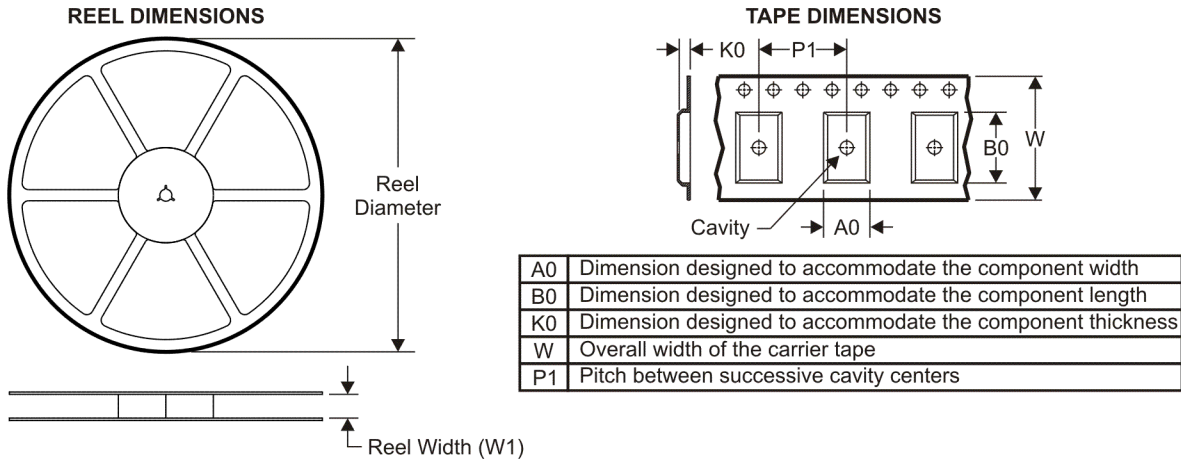

QUADRANT ASSIGNMENTS FOR PIN 1 ORIENTATION IN TAPE



*All dimensions are nominal

Device	Package Type	Package Drawing	Pins	SPQ	Reel Diameter (mm)	Reel Width W1 (mm)	A0 (mm)	B0 (mm)	K0 (mm)	P1 (mm)	W (mm)	Pin1 Quadrant
ADS7845E/2K5	SSOP/QSOP	DBQ	16	2500	330.0	12.4	6.4	5.2	2.1	8.0	12.0	Q1

TAPE AND REEL BOX DIMENSIONS



*All dimensions are nominal

Device	Package Type	Package Drawing	Pins	SPQ	Length (mm)	Width (mm)	Height (mm)
ADS7845E/2K5	SSOP/QSOP	DBQ	16	2500	346.0	346.0	29.0

IMPORTANT NOTICE

Texas Instruments Incorporated and its subsidiaries (TI) reserve the right to make corrections, modifications, enhancements, improvements, and other changes to its products and services at any time and to discontinue any product or service without notice. Customers should obtain the latest relevant information before placing orders and should verify that such information is current and complete. All products are sold subject to TI's terms and conditions of sale supplied at the time of order acknowledgment.

TI warrants performance of its hardware products to the specifications applicable at the time of sale in accordance with TI's standard warranty. Testing and other quality control techniques are used to the extent TI deems necessary to support this warranty. Except where mandated by government requirements, testing of all parameters of each product is not necessarily performed.

TI assumes no liability for applications assistance or customer product design. Customers are responsible for their products and applications using TI components. To minimize the risks associated with customer products and applications, customers should provide adequate design and operating safeguards.

TI does not warrant or represent that any license, either express or implied, is granted under any TI patent right, copyright, mask work right, or other TI intellectual property right relating to any combination, machine, or process in which TI products or services are used. Information published by TI regarding third-party products or services does not constitute a license from TI to use such products or services or a warranty or endorsement thereof. Use of such information may require a license from a third party under the patents or other intellectual property of the third party, or a license from TI under the patents or other intellectual property of TI.

Reproduction of TI information in TI data books or data sheets is permissible only if reproduction is without alteration and is accompanied by all associated warranties, conditions, limitations, and notices. Reproduction of this information with alteration is an unfair and deceptive business practice. TI is not responsible or liable for such altered documentation. Information of third parties may be subject to additional restrictions.

Resale of TI products or services with statements different from or beyond the parameters stated by TI for that product or service voids all express and any implied warranties for the associated TI product or service and is an unfair and deceptive business practice. TI is not responsible or liable for any such statements.

TI products are not authorized for use in safety-critical applications (such as life support) where a failure of the TI product would reasonably be expected to cause severe personal injury or death, unless officers of the parties have executed an agreement specifically governing such use. Buyers represent that they have all necessary expertise in the safety and regulatory ramifications of their applications, and acknowledge and agree that they are solely responsible for all legal, regulatory and safety-related requirements concerning their products and any use of TI products in such safety-critical applications, notwithstanding any applications-related information or support that may be provided by TI. Further, Buyers must fully indemnify TI and its representatives against any damages arising out of the use of TI products in such safety-critical applications.

TI products are neither designed nor intended for use in military/aerospace applications or environments unless the TI products are specifically designated by TI as military-grade or "enhanced plastic." Only products designated by TI as military-grade meet military specifications. Buyers acknowledge and agree that any such use of TI products which TI has not designated as military-grade is solely at the Buyer's risk, and that they are solely responsible for compliance with all legal and regulatory requirements in connection with such use.

TI products are neither designed nor intended for use in automotive applications or environments unless the specific TI products are designated by TI as compliant with ISO/TS 16949 requirements. Buyers acknowledge and agree that, if they use any non-designated products in automotive applications, TI will not be responsible for any failure to meet such requirements.

Following are URLs where you can obtain information on other Texas Instruments products and application solutions:

Products

Amplifiers	amplifier.ti.com
Data Converters	dataconverter.ti.com
DLP® Products	www.dlp.com
DSP	dsp.ti.com
Clocks and Timers	www.ti.com/clocks
Interface	interface.ti.com
Logic	logic.ti.com
Power Mgmt	power.ti.com
Microcontrollers	microcontroller.ti.com
RFID	www.ti-rfid.com
RF/IF and ZigBee® Solutions	www.ti.com/lprf

Applications

Audio	www.ti.com/audio
Automotive	www.ti.com/automotive
Broadband	www.ti.com/broadband
Digital Control	www.ti.com/digitalcontrol
Medical	www.ti.com/medical
Military	www.ti.com/military
Optical Networking	www.ti.com/opticalnetwork
Security	www.ti.com/security
Telephony	www.ti.com/telephony
Video & Imaging	www.ti.com/video
Wireless	www.ti.com/wireless

Mailing Address: Texas Instruments, Post Office Box 655303, Dallas, Texas 75265
Copyright © 2009, Texas Instruments Incorporated

Looking for pricing, stock, or lifecycle information?

Click below to explore more details on WIN SOURCE:

 [View ADS7845E/2K5](#) on WIN SOURCE

 [Texas Instruments](#) Information

Optimize Your Supply Chain with WIN SOURCE Solutions

-  Global Sourcing Solution
-  Obsolete Management
-  Cost Control Management
-  Shortage Management
-  Alternative Solution
-  Excess Inventory Management