



**THE DATASHEET OF  
THS3122IDRG4**



## THS312x Low-Noise, High-Speed, 450-mA Current Feedback Amplifiers

### 1 Features

- Low Noise:
  - 2.9-pA/ $\sqrt{\text{Hz}}$  Noninverting Current Noise
  - 10.8-pA/ $\sqrt{\text{Hz}}$  Inverting Current Noise
  - 2.2-nV/ $\sqrt{\text{Hz}}$  Voltage Noise
  - 128-MHz, –3-dB BW ( $R_L = 50 \Omega$ ,  $R_F = 470 \Omega$ )
  - 1550-V/ $\mu\text{s}$  Slew Rate ( $G = 2$ ,  $R_L = 50 \Omega$ )
- High Output Current: 450 mA
- High Speed:
  - 128-MHz, –3-dB BW ( $R_L = 50 \Omega$ ,  $R_F = 470 \Omega$ )
  - 1550-V/ $\mu\text{s}$  Slew Rate ( $G = 2$ ,  $R_L = 50 \Omega$ )
  - 26- $V_{PP}$  Output Voltage,  $R_L = 50 \Omega$
  - –80 dBc (1 MHz, 2  $V_{PP}$ ,  $G = 2$ )
- Wide Output Swing:
  - 26- $V_{PP}$  Output Voltage,  $R_L = 50 \Omega$
  - –80 dBc (1 MHz, 2  $V_{PP}$ ,  $G = 2$ )
  - 370- $\mu\text{A}$  Shutdown Supply Current
- Low Distortion:
  - –80 dBc (1 MHz, 2  $V_{PP}$ ,  $G = 2$ )
  - 370- $\mu\text{A}$  Shutdown Supply Current
- Low-Power Shutdown Mode (THS3125)
  - 370- $\mu\text{A}$  Shutdown Supply Current
- Standard SOIC, HSOP PowerPAD™, and HTSSOP PowerPAD Packages

### 2 Applications

- Video Distribution
- Instrumentation
- Line Drivers
- Motor Drivers
- Piezo Drivers

### 3 Description

The THS3122 and THS3125 are low-noise, high-speed current feedback amplifiers, with high output current drive. This makes them ideal for any application that requires low distortion over a wide frequency with heavy loads. The THS3122 and THS3125 can drive four serially-terminated video lines while maintaining a differential gain error less than 0.03%.

The high output drive capability of the THS3122 and THS3125 enables the devices to drive 50- $\Omega$  loads with low distortion over a wide range of output voltages:

- –80-dBc THD at 2  $V_{PP}$
- –75-dBc THD at 8  $V_{PP}$

The THS3122 and THS3125 operate from  $\pm 5$ -V to  $\pm 15$ -V supply voltages while drawing as little as 7.2 mA of supply current per channel. The THS3125 offers a low-power shutdown mode, reducing the supply current to only 370  $\mu\text{A}$ . The THS3122 and THS3125 are packaged in SOIC, HSOP, and HTSSOP packages.

#### Device Information<sup>(1)</sup>

PART NUMBER	PACKAGE	BODY SIZE (NOM)
THS3122	SOIC (8)	4.90 mm x 3.91 mm
	HSOP (8)	4.89 mm x 3.90 mm
THS3125	SOIC (14)	8.65 mm x 3.91 mm
	HTSSOP (14)	5.00 mm x 4.40 mm

(1) For all available packages, see the package option addendum at the end of the data sheet.

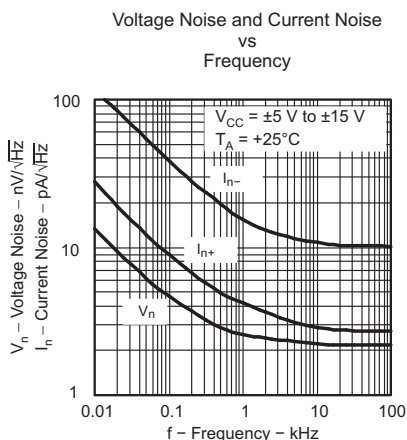

**THS3122**  
SOIC (D) and  
HSOP (SOIC PowerPAD, DDA) Package  
(Top View)

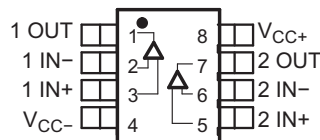

**THS3125**  
SOIC (D) and  
HTSSOP PowerPAD (PWP) Package  
(Top View)

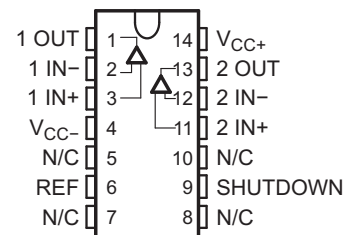

## Table of Contents

<b>1 Features</b> ..... 1 <b>2 Applications</b> ..... 1 <b>3 Description</b> ..... 1 <b>4 Revision History</b> ..... 2 <b>5 Device Options</b> ..... 3 <b>6 Pin Configuration and Functions</b> ..... 3 <b>7 Specifications</b> ..... 4 7.1 Absolute Maximum Ratings ..... 4 7.2 Dissipation Ratings Table ..... 4 7.3 Recommended Operating Conditions ..... 4 7.4 Electrical Characteristics: Dynamic Performance ..... 5 7.5 Electrical Characteristics: Noise and Distortion Performance ..... 5 7.6 Electrical Characteristics: DC Performance ..... 6 7.7 Electrical Characteristics: Input Characteristics ..... 6 7.8 Electrical Characteristics: Output Characteristics ..... 6 7.9 Electrical Characteristics: Power Supply ..... 7 7.10 Electrical Characteristics: Shutdown Characteristics (THS3125 Only) ..... 7	7.11 Typical Characteristics: Table Of Graphs ..... 7 7.12 Typical Characteristics ..... 8 <b>8 Detailed Description</b> ..... 14 8.1 Overview ..... 14 8.2 Feature Description ..... 14 8.3 Device Functional Modes ..... 16 <b>9 Application and Implementation</b> ..... 18 9.1 Application Information ..... 18 <b>10 Layout</b> ..... 22 10.1 Layout Guidelines ..... 22 <b>11 Device and Documentation Support</b> ..... 26 11.1 Related Links ..... 26 11.2 Community Resources ..... 26 11.3 Trademarks ..... 26 11.4 Electrostatic Discharge Caution ..... 26 11.5 Glossary ..... 26 <b>12 Mechanical, Packaging, and Orderable Information</b> ..... 26
--	---

## 4 Revision History

NOTE: Page numbers for previous revisions may differ from page numbers in the current version.

Changes from Revision D (February 2011) to Revision E	Page
• Added missing minus sign to temperature range in Available Options table .....	3
• Changed Input Offset parameter maximum values in Electrical Characteristics for DC Performance .....	6
• Added Detailed Description section.....	14
• Added Application and Implementation section.....	18
• Change Application Information section .....	18

Changes from Revision C (July 2010) to Revision D	Page
• Changed output current (absolute maximum) from 275 mA to 550 mA.....	4

Changes from Revision B (October, 2009) to Revision C	Page
• Corrected REF pin name for THS3125 shown in front-page figure .....	1
• Deleted <i>Shutdown pin input levels</i> parameters and specifications from <i>Recommended Operating Conditions</i> table.....	4
• Updated <i>Shutdown Characteristics</i> table test conditions; changed GND to REF, corrected $V_{SHDN}$ notations.....	7
• Added $V_{REF}$ and $V_{SHDN}$ parameters and specifications to <i>Shutdown Characteristics</i> table .....	7
• Revised second and fourth paragraphs of <i>Saving Power with Shutdown Functionality</i> section.....	14
• Updated equation in <i>Power-Down Reference Pin Operation</i> section that describes usable range at the REF pin.....	15
• Revised paragraph in <i>Power-Down Reference Pin Operation</i> that discusses behavior of unterminated REF pin.....	15

## 5 Device Options<sup>(1)</sup>

T <sub>A</sub>	PACKAGED DEVICE				EVALUATION MODULES
	SOIC-8 (D)	HSOP-8 PowerPAD (DDA)	SOIC-14 (D)	HTSSOP-14 (PWP)	
0°C to +70°C	THS3122CD	THS3122CDDA	THS3125CD	THS3125CPWP	THS3122EVM, THS3125EVM
–40°C to +85°C	THS3122ID	THS3122IDDA	THS3125ID	THS3125IPWP	

(1) For the most current package and ordering information, see the Package Option Addendum located at the end of this data sheet.

## 6 Pin Configuration and Functions

**THS3122: D and DDA Packages**  
SOIC-8 and HSOP-8  
Top View

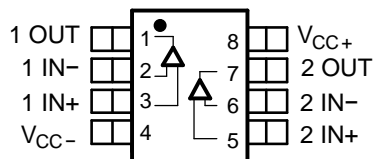

**THS3125: D and PWP Packages**  
SOIC-14 and HTSSOP-14  
Top View

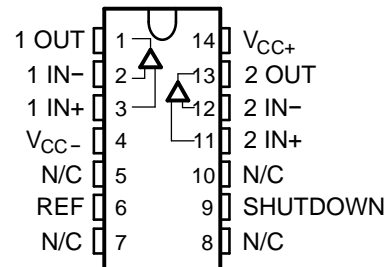

### Pin Functions

NAME	PIN		I/O	DESCRIPTION
	THS3122	THS3125		
1 IN+	3	3	I	Noninverting amplifier 1 input
1 IN–	2	2	I	Inverting amplifier 1 input
1 OUT	1	1	O	Amplifier 1 output
2 IN+	5	11	I	Noninverting amplifier 2 input
2 IN–	6	12	I	Inverting amplifier 2 input
2 OUT	7	13	O	Amplifier 2 output
N/C	—	5, 7, 8, 10	—	No internal connection.
SHUTDOWN	—	9	I	Shutdown control. Logic low = active; logic high = power down.
REF	—	6	I	Reference for shutdown threshold control
V <sub>CC+</sub>	8	14	P	Positive power supply
V <sub>CC–</sub>	4	4	P	Negative power supply

## 7 Specifications

### 7.1 Absolute Maximum Ratings

over operating free-air temperature range (unless otherwise noted)<sup>(1)</sup>

		MIN	MAX	UNIT
Supply voltage, $V_{CC+}$ to $V_{CC-}$			33	V
Input voltage		$-V_{CC}$	$+V_{CC}$	V
Differential input voltage		-4	+4	V
Output current <sup>(2)</sup>			550	mA
Total power dissipation at (or below) +25°C free-air temperature		See <a href="#">Dissipation Ratings Table</a>		
Maximum junction temperature			150	°C
Operating free-air temperature, $T_A$	Commercial	0	70	°C
	Industrial	-40	+85	°C
Storage temperature, $T_{stg}$	Commercial	-65	+125	°C
	Industrial	-65	+125	°C

- (1) Stresses beyond those listed under *Absolute Maximum Ratings* may cause permanent damage to the device. These are stress ratings only, which do not imply functional operation of the device at these or any other conditions beyond those indicated under *Recommended Operating Conditions*. Exposure to absolute-maximum-rated conditions for extended periods may affect device reliability.
- (2) The THS3122 and THS3125 may incorporate a PowerPAD on the underside of the chip. This pad acts as a heatsink and must be connected to a thermally dissipating plane for proper power dissipation. Failure to do so may result in exceeding the maximum junction temperature which could permanently damage the device. See TI Technical Brief [SLMA002](#) for more information about utilizing the PowerPAD thermally-enhanced package.

### 7.2 Dissipation Ratings Table

PACKAGE	$\theta_{JA}$	$T_A = +25^\circ\text{C}$ POWER RATING
D-8	95°C/W <sup>(1)</sup>	1.32 W
DDA	67°C/W	1.87 W
D-14	66.6°C/W <sup>(1)</sup>	1.88 W
PWP	37.5°C/W	3.3 W

- (1) These data were taken using the JEDEC proposed high-K test PCB. For the JEDEC low-K test PCB, the  $\theta_{JA}$  is 168°C/W for the D-8 package and 122.3°C/W for the D-14 package.

### 7.3 Recommended Operating Conditions

		MIN	NOM	MAX	UNIT
Supply voltage, $V_{CC+}$ to $V_{CC-}$	Dual supply	±5		±15	V
	Single supply	10		30	V
Operating free-air temperature, $T_A$	C-suffix	0		+70	°C
	I-suffix	-40		+85	°C

## 7.4 Electrical Characteristics: Dynamic Performance

Over operating free-air temperature range,  $T_A = +25^\circ\text{C}$ ,  $V_{CC} = \pm 15\text{ V}$ ,  $R_F = 750\ \Omega$ , and  $R_L = 100\ \Omega$  (unless otherwise noted).

PARAMETER		TEST CONDITIONS			MIN	TYP	MAX	UNIT
BW	Small-signal bandwidth (–3 dB)	$R_L = 50\ \Omega$	$R_F = 50\ \Omega, G = 1$	$V_{CC} = \pm 5\text{ V}$		138		MHz
				$V_{CC} = \pm 15\text{ V}$		160		MHz
		$R_L = 50\ \Omega$	$R_F = 470\ \Omega, G = 2$	$V_{CC} = \pm 5\text{ V}$		126		MHz
				$V_{CC} = \pm 15\text{ V}$		128		MHz
	Bandwidth (0.1 dB)	$R_F = 470\ \Omega, G = 2$	$V_{CC} = \pm 5\text{ V}$		20		MHz	
			$V_{CC} = \pm 15\text{ V}$		30		MHz	
Full power bandwidth	$G = -1$		$V_{O(PP)} = 4\text{ V}$	$V_{CC} = \pm 5\text{ V}$		47		MHz
			$V_{O(PP)} = 20\text{ V}$	$V_{CC} = \pm 15\text{ V}$		64		MHz
			$V_O = 10\text{ V}_{PP}$	$V_{CC} = \pm 15\text{ V}$		1550		V/ $\mu\text{s}$
			$V_O = 5\text{ V}_{PP}$	$V_{CC} = \pm 15\text{ V}$		500		V/ $\mu\text{s}$
SR	Slew rate <sup>(1)</sup> , $G = 8$	$G = 2, R_F = 680\ \Omega$	$V_O = 10\text{ V}_{PP}$	$V_{CC} = \pm 15\text{ V}$		1550		V/ $\mu\text{s}$
			$V_O = 5\text{ V}_{PP}$	$V_{CC} = \pm 5\text{ V}$		500		V/ $\mu\text{s}$
				$V_{CC} = \pm 15\text{ V}$		1000		V/ $\mu\text{s}$
$t_s$	Settling time to 0.1%	$G = -1$	$V_O = 2\text{ V}_{PP}$	$V_{CC} = \pm 5\text{ V}$		53		ns
			$V_O = 5\text{ V}_{PP}$	$V_{CC} = \pm 15\text{ V}$		64		ns

(1) Slew rate is defined from the 25% to the 75% output levels.

## 7.5 Electrical Characteristics: Noise and Distortion Performance

Over operating free-air temperature range,  $T_A = +25^\circ\text{C}$ ,  $V_{CC} = \pm 15\text{ V}$ ,  $R_F = 750\ \Omega$ , and  $R_L = 100\ \Omega$  (unless otherwise noted).

PARAMETER		TEST CONDITIONS			MIN	TYP	MAX	UNIT
THD	Total harmonic distortion	$G = 2, R_F = 470\ \Omega, V_{CC} = \pm 15\text{ V}, f = 1\text{ MHz}$	$V_{O(PP)} = 2\text{ V}$			–80		dBc
			$V_{O(PP)} = 8\text{ V}$			–75		dBc
			$V_{O(PP)} = 2\text{ V}$			–77		dBc
			$V_{O(PP)} = 5\text{ V}$			–76		dBc
$V_n$	Input voltage noise	$V_{CC} = \pm 5\text{ V}, \pm 15\text{ V}$	$f = 10\text{ kHz}$		2.2		nV/ $\sqrt{\text{Hz}}$	
$I_n$	Input current noise	Noninverting Input	$V_{CC} = \pm 5\text{ V}, \pm 15\text{ V}$	$f = 10\text{ kHz}$		2.9		pA/ $\sqrt{\text{Hz}}$
		Inverting Input	$V_{CC} = \pm 5\text{ V}, \pm 15\text{ V}$	$f = 10\text{ kHz}$		10.8		pA/ $\sqrt{\text{Hz}}$
Crosstalk		$G = 2, f = 1\text{ MHz}, V_O = 2\text{ V}_{PP}$	$V_{CC} = \pm 5\text{ V}$			–67		dBc
			$V_{CC} = \pm 15\text{ V}$			–67		dBc
Differential gain error		$G = 2, R_L = 150\ \Omega$ 40 IRE modulation, $\pm 100$ IRE Ramp NTSC and PAL	$V_{CC} = \pm 5\text{ V}$			0.01%		
			$V_{CC} = \pm 15\text{ V}$			0.01%		
Differential phase error		$G = 2, R_L = 150\ \Omega$ 40 IRE modulation $\pm 100$ IRE Ramp NTSC and PAL	$V_{CC} = \pm 5\text{ V}$			0.011		degrees
			$V_{CC} = \pm 15\text{ V}$			0.011		degrees

## 7.6 Electrical Characteristics: DC Performance

Over operating free-air temperature range,  $T_A = +25^\circ\text{C}$ ,  $V_{CC} = \pm 15\text{ V}$ ,  $R_F = 750\ \Omega$ , and  $R_L = 100\ \Omega$  (unless otherwise noted).

PARAMETER		TEST CONDITIONS	MIN	TYP	MAX	UNIT
$V_{IO}$	Input offset voltage	$V_{IC} = 0\text{ V}$ , $V_O = 0\text{ V}$ , $V_{CC} = \pm 5\text{ V}$ , $V_{CC} = \pm 15\text{ V}$	$T_A = +25^\circ\text{C}$	6	$\pm 20$	mV
			$T_A = \text{full range}$		$\pm 25$	mV
	Channel offset voltage matching	$V_{IC} = 0\text{ V}$ , $V_O = 0\text{ V}$ , $V_{CC} = \pm 5\text{ V}$ , $V_{CC} = \pm 15\text{ V}$	$T_A = +25^\circ\text{C}$	1	3	mV
			$T_A = \text{full range}$		4	mV
	Offset drift	$V_{IC} = 0\text{ V}$ , $V_O = 0\text{ V}$ , $V_{CC} = \pm 5\text{ V}$ , $V_{CC} = \pm 15\text{ V}$	$T_A = \text{full range}$	10		$\mu\text{V}/^\circ\text{C}$
$I_{IB}$	IN- Input bias current	$V_{IC} = 0\text{ V}$ , $V_O = 0\text{ V}$ , $V_{CC} = \pm 5\text{ V}$ , $V_{CC} = \pm 15\text{ V}$	$T_A = +25^\circ\text{C}$	6	23	$\mu\text{A}$
			$T_A = \text{full range}$		30	$\mu\text{A}$
	IN+ Input bias current		$T_A = +25^\circ\text{C}$	0.33	2	$\mu\text{A}$
			$T_A = \text{full range}$		3	$\mu\text{A}$
$I_{IO}$	Input offset current	$V_{IC} = 0\text{ V}$ , $V_O = 0\text{ V}$ , $V_{CC} = \pm 5\text{ V}$ , $V_{CC} = \pm 15\text{ V}$	$T_A = +25^\circ\text{C}$	5.4	22	$\mu\text{A}$
			$T_A = \text{full range}$		30	$\mu\text{A}$
$Z_{OL}$	Open-loop transimpedance	$V_{CC} = \pm 5\text{ V}$ , $V_{CC} = \pm 15\text{ V}$	$R_L = 1\text{ k}\Omega$	1		M $\Omega$

## 7.7 Electrical Characteristics: Input Characteristics

Over operating free-air temperature range,  $T_A = +25^\circ\text{C}$ ,  $V_{CC} = \pm 15\text{ V}$ ,  $R_F = 750\ \Omega$ , and  $R_L = 100\ \Omega$  (unless otherwise noted).

PARAMETER		TEST CONDITIONS	MIN	TYP	MAX	UNIT
$V_{ICR}$	Input common-mode voltage range	$V_{CC} = \pm 5\text{ V}$	$T_A = \text{full range}$	$\pm 2.5$	$\pm 2.7$	V
		$V_{CC} = \pm 15\text{ V}$	$T_A = \text{full range}$	$\pm 12.5$	$\pm 12.7$	V
CMRR	Common-mode rejection ratio	$V_{CC} = \pm 5\text{ V}$ , $V_I = -2.5\text{ V to } +2.5\text{ V}$	$T_A = +25^\circ\text{C}$	58	62	dB
			$T_A = \text{full range}$	56		dB
		$V_{CC} = \pm 15\text{ V}$ , $V_I = -12.5\text{ V to } +12.5\text{ V}$	$T_A = +25^\circ\text{C}$	63	67	dB
			$T_A = \text{full range}$	60		dB
$R_i$	Input resistance		IN+		1.5	M $\Omega$
			IN-		15	$\Omega$
$C_i$	Input capacitance			2	pF	

## 7.8 Electrical Characteristics: Output Characteristics

Over operating free-air temperature range,  $T_A = +25^\circ\text{C}$ ,  $V_{CC} = \pm 15\text{ V}$ ,  $R_F = 750\ \Omega$ , and  $R_L = 100\ \Omega$  (unless otherwise noted).

PARAMETER		TEST CONDITIONS	MIN	TYP	MAX	UNIT
$V_O$	Output voltage swing	$G = 4$ , $V_I = 1.06\text{ V}$ , $V_{CC} = \pm 5\text{ V}$ , $R_L = 1\text{ k}\Omega$	$T_A = +25^\circ\text{C}$		4.1	V
		$G = 4$ , $V_I = 1.025\text{ V}$ , $V_{CC} = \pm 5\text{ V}$ , $R_L = 50\ \Omega$	$T_A = +25^\circ\text{C}$	3.8	4	V
			$T_A = \text{full range}$	3.7		V
		$G = 4$ , $V_I = 3.6\text{ V}$ , $V_{CC} = \pm 15\text{ V}$ , $R_L = 1\text{ k}\Omega$	$T_A = +25^\circ\text{C}$		14.2	V
			$T_A = \text{full range}$	12	13.3	V
$I_O$	Output current drive	$G = 4$ , $V_I = 1.025\text{ V}$ , $V_{CC} = \pm 5\text{ V}$ , $R_L = 10\ \Omega$	$T_A = +25^\circ\text{C}$	200	280	mA
			$T_A = +25^\circ\text{C}$	360	440	mA
$r_o$	Output resistance	Open loop	$T_A = +25^\circ\text{C}$	14		$\Omega$

## 7.9 Electrical Characteristics: Power Supply

Over operating free-air temperature range,  $T_A = +25^\circ\text{C}$ ,  $V_{CC} = \pm 15\text{ V}$ ,  $R_F = 750\ \Omega$ , and  $R_L = 100\ \Omega$  (unless otherwise noted).

PARAMETER		TEST CONDITIONS		MIN	TYP	MAX	UNIT
$I_{CC}$	Quiescent current (per channel)	$V_{CC} = \pm 5\text{ V}$	$T_A = +25^\circ\text{C}$		7.2	9	mA
			$T_A = \text{full range}$			10	mA
		$V_{CC} = \pm 15\text{ V}$	$T_A = +25^\circ\text{C}$		8.4	10.5	mA
			$T_A = \text{full range}$			11.5	mA
PSRR	Power-supply rejection ratio	$V_{CC} = \pm 5\text{ V} \pm 1\text{ V}$	$T_A = +25^\circ\text{C}$	53	60		dB
			$T_A = \text{full range}$	50			dB
		$V_{CC} = \pm 15\text{ V} \pm 1\text{ V}$	$T_A = +25^\circ\text{C}$	60	69		dB
			$T_A = \text{full range}$	55			dB

## 7.10 Electrical Characteristics: Shutdown Characteristics (THS3125 Only)

Over operating free-air temperature range,  $T_A = +25^\circ\text{C}$ ,  $V_{CC} = \pm 15\text{ V}$ ,  $R_F = 750\ \Omega$ , and  $R_L = 100\ \Omega$  (unless otherwise noted).

PARAMETER		TEST CONDITIONS		MIN	TYP	MAX	UNIT
$I_{CC}(\text{SHDN})$	Shutdown quiescent current (per channel)	$\text{REF} = 0\text{ V}$ , $V_{CC} = \pm 5\text{ V to } \pm 15\text{ V}$	$V_{\text{SHDN}} = 3.3\text{ V}$		370	500	$\mu\text{A}$
$t_{\text{DIS}}$	Disable time <sup>(1)</sup>	$\text{REF} = 0\text{ V}$ , $V_{CC} = \pm 5\text{ V to } \pm 15\text{ V}$			500		$\mu\text{s}$
$t_{\text{EN}}$	Enable time <sup>(1)</sup>	$\text{REF} = 0\text{ V}$ , $V_{CC} = \pm 5\text{ V to } \pm 15\text{ V}$			200		$\mu\text{s}$
$I_{\text{IL}}(\text{SHDN})$	Shutdown pin low level leakage current	$\text{REF} = 0\text{ V}$ , $V_{CC} = \pm 5\text{ V to } \pm 15\text{ V}$	$V_{\text{SHDN}} = 0\text{ V}$		18	25	$\mu\text{A}$
$I_{\text{IH}}(\text{SHDN})$	Shutdown pin high level leakage current	$\text{REF} = 0\text{ V}$ , $V_{CC} = \pm 5\text{ V to } \pm 15\text{ V}$	$V_{\text{SHDN}} = 3.3\text{ V}$		110	130	$\mu\text{A}$
$V_{\text{REF}}$	REF pin voltage level			$V_{CC-}$		$V_{CC+} - 4$	V
$V_{\text{SHDN}}$	SHUTDOWN pin voltage level	Enable				$\text{REF} + 0.8$	V
		Disable		$\text{REF} + 2$			V

(1) Disable and enable times are defined as the time from when the shutdown signal is applied to the SHDN pin to when the supply current has reached half of its final value.

## 7.11 Typical Characteristics: Table Of Graphs

TITLE		FIGURE	
Small-signal closed-loop gain	vs Frequency	<a href="#">Figure 1 to Figure 10</a>	
Small- and large-signal output	vs Frequency	<a href="#">Figure 11, Figure 12</a>	
Harmonic distortion	vs Frequency	<a href="#">Figure 13 to Figure 15</a>	
	vs Peak-to-peak output voltage	<a href="#">Figure 16, Figure 17</a>	
$V_n, I_n$	Voltage noise and current noise	vs Frequency	<a href="#">Figure 18</a>
CMRR	Common-mode rejection ratio	vs Frequency	<a href="#">Figure 19</a>
	Crosstalk	vs Frequency	<a href="#">Figure 20</a>
$Z_o$	Output impedance	vs Frequency	<a href="#">Figure 21</a>
SR	Slew rate	vs Output voltage step	<a href="#">Figure 22</a>
$V_{\text{IO}}$	Input offset voltage	vs Free-air temperature	<a href="#">Figure 24</a>
		vs Common-mode input voltage	<a href="#">Figure 24</a>
$I_B$	Input bias current	vs Free-air temperature	<a href="#">Figure 25</a>
$V_O$	Output voltage	vs Load current	<a href="#">Figure 26</a>
	Quiescent current	vs Free-air temperature	<a href="#">Figure 27</a>
		vs Supply voltage	<a href="#">Figure 28</a>
$I_{CC}$	Shutdown supply current	vs Free-air temperature	<a href="#">Figure 29</a>
	Differential gain and phase error	vs 75- $\Omega$ serially terminated loads	<a href="#">Figure 30, Figure 31</a>
	Shutdown response		<a href="#">Figure 32</a>
	Small-signal pulse response		<a href="#">Figure 33, Figure 34</a>
	Large-signal pulse response		<a href="#">Figure 35, Figure 36</a>

### 7.12 Typical Characteristics

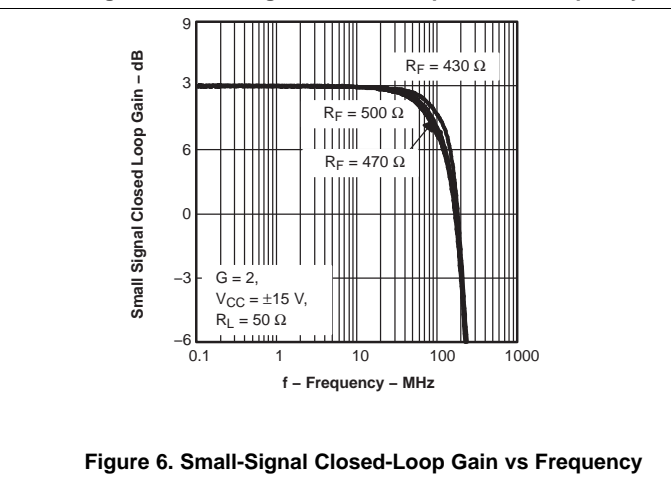
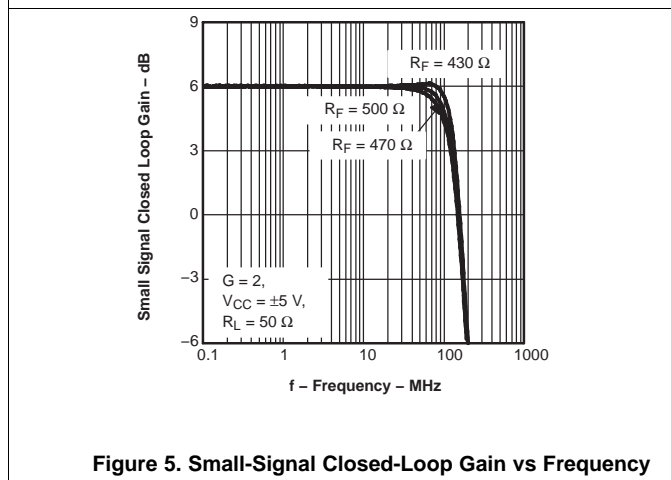
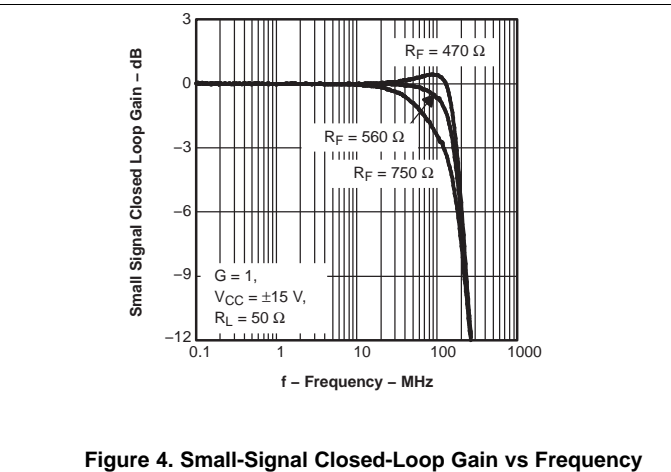
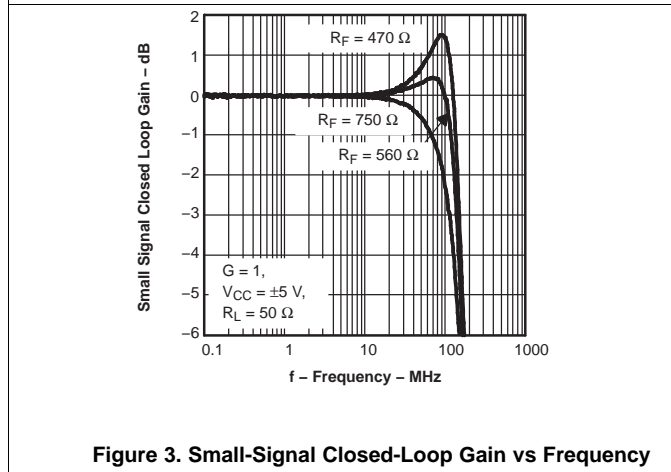
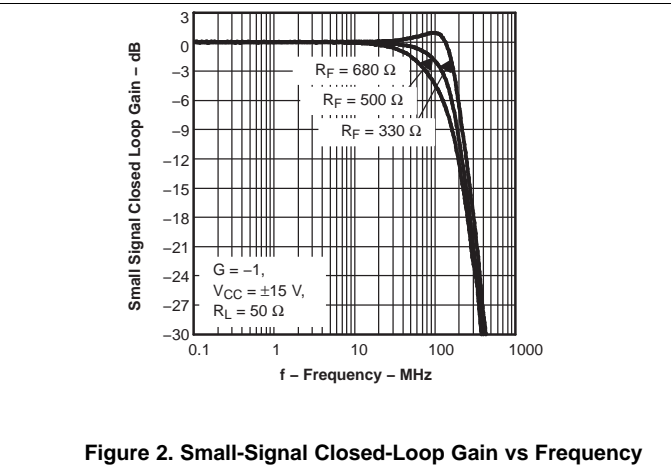
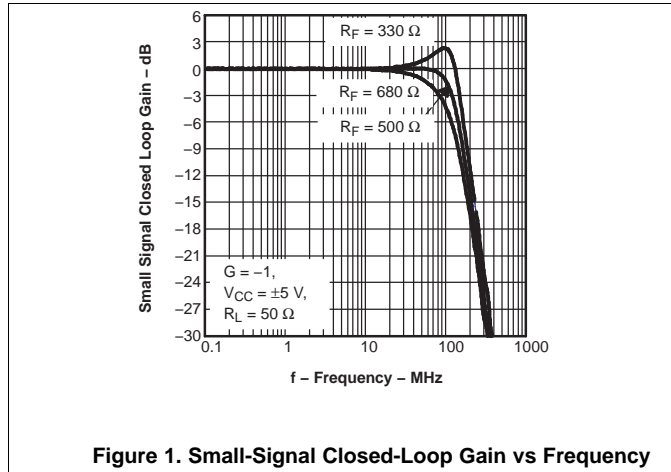

Typical Characteristics (continued)

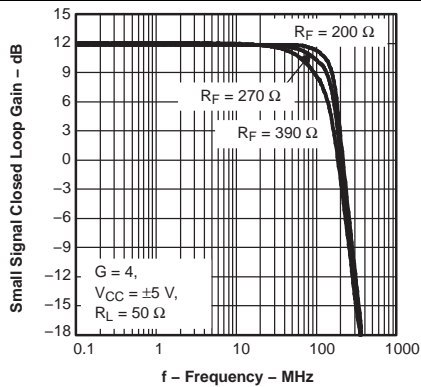

Figure 7. Small-Signal Closed-Loop Gain vs Frequency

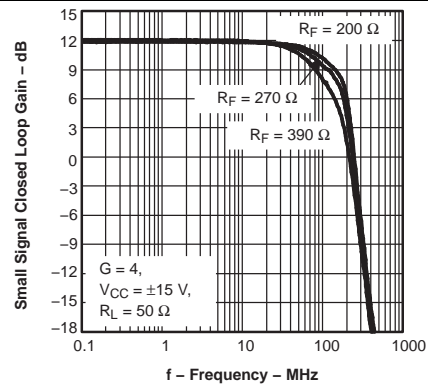

Figure 8. Small-Signal Closed-Loop Gain vs Frequency

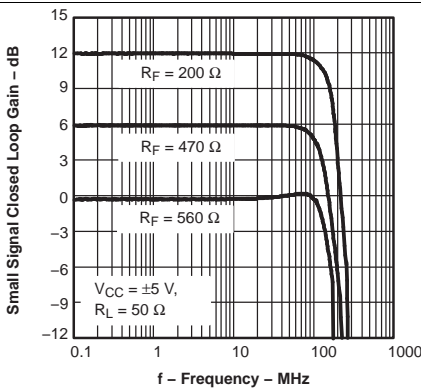

Figure 9. Small-Signal Closed-Loop Gain vs Frequency

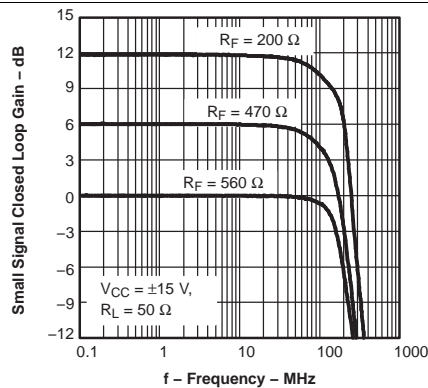

Figure 10. Small-Signal Closed-Loop Gain vs Frequency

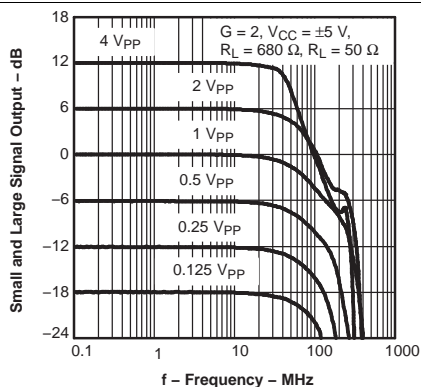

Figure 11. Small- and Large-Signal Output vs Frequency

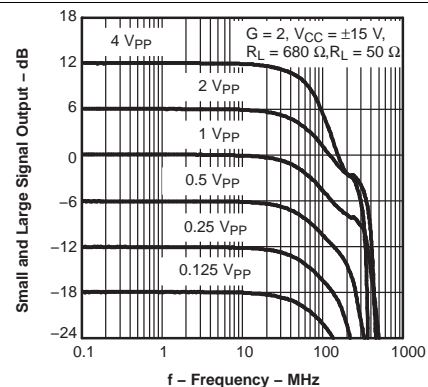

Figure 12. Small- and Large-Signal Output vs Frequency

Typical Characteristics (continued)

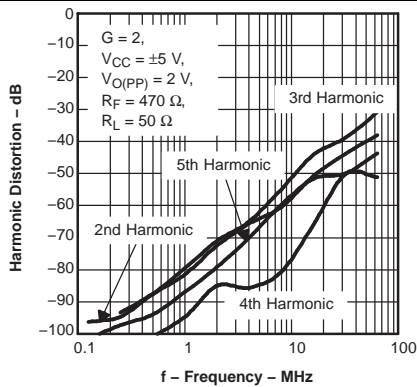

Figure 13. Harmonic Distortion vs Frequency

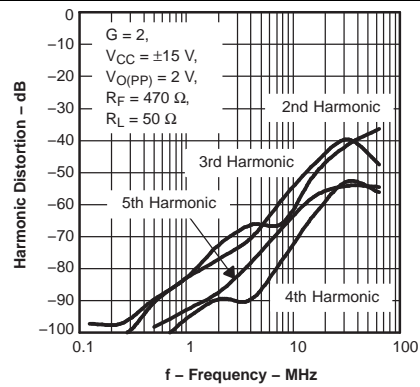

Figure 14. Harmonic Distortion vs Frequency

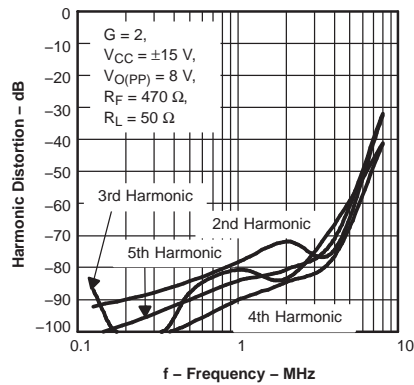

Figure 15. Harmonic Distortion vs Frequency

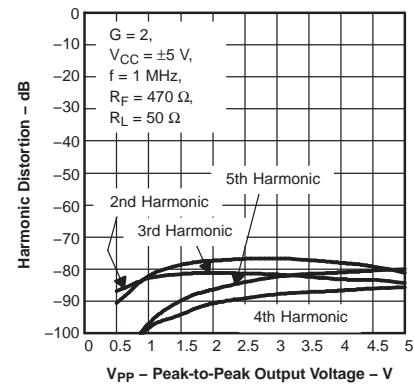

Figure 16. Harmonic Distortion vs Peak-to-Peak Output Voltage

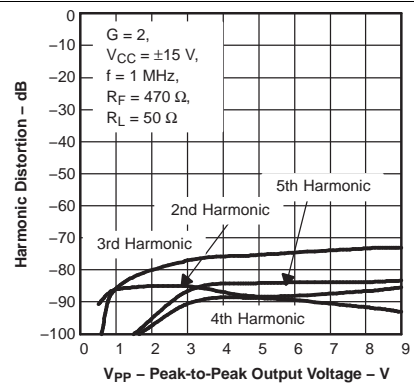

Figure 17. Harmonic Distortion vs Peak-to-Peak Output Voltage

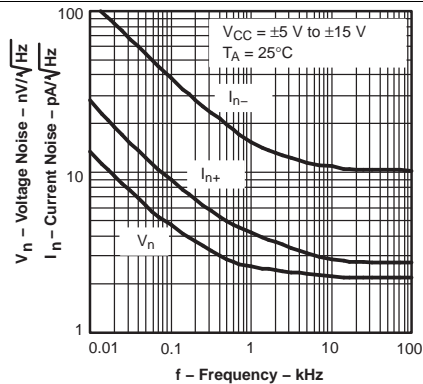

Figure 18. Voltage Noise and Current Noise vs Frequency

Typical Characteristics (continued)

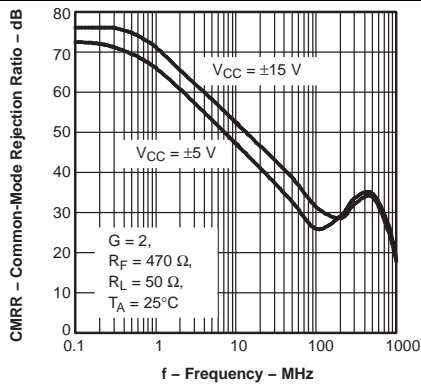

Figure 19. Common-Mode Rejection Ratio vs Frequency

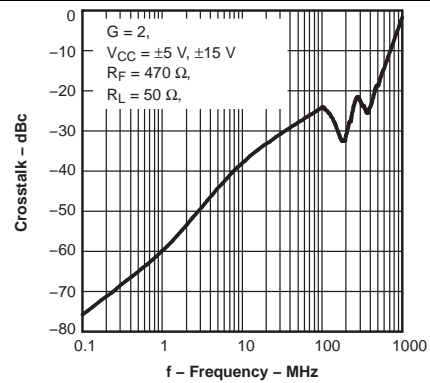

Figure 20. Crosstalk vs Frequency

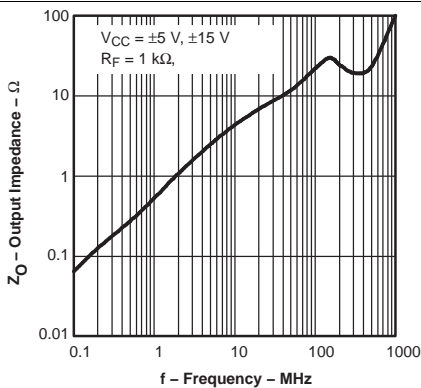

Figure 21. Output Impedance vs Frequency

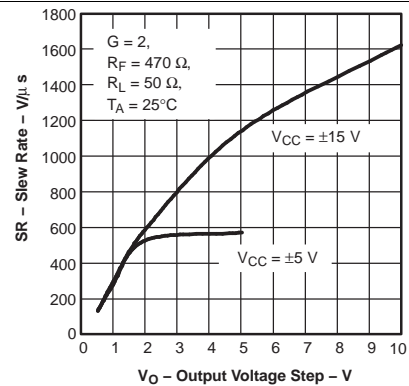

Figure 22. Slew Rate vs Output Voltage Step

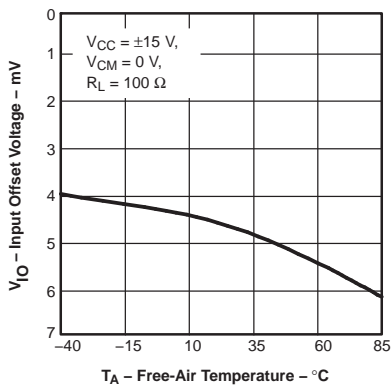

Figure 23. Input Offset Voltage vs Free-Air Temperature

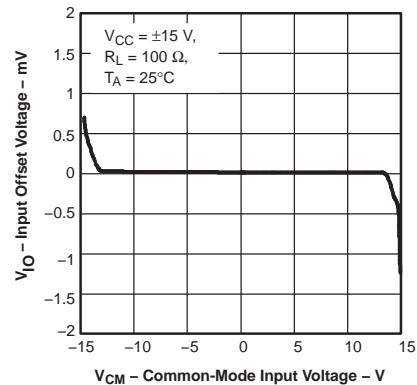

Figure 24. Input Offset Voltage vs Common-Mode Input Voltage

Typical Characteristics (continued)

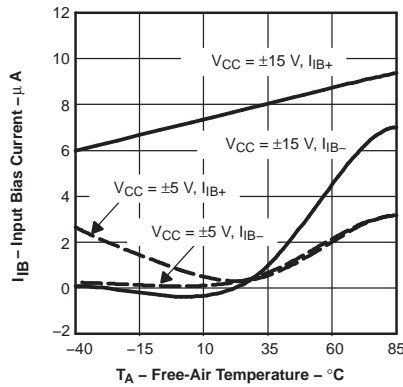

Figure 25. Input Bias Current vs Free-Air Temperature

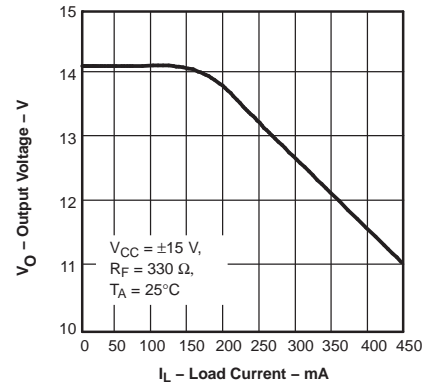

Figure 26. Output Voltage vs Load Current

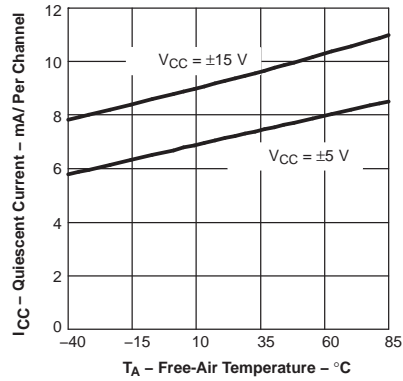

Figure 27. Quiescent Current vs Free-Air Temperature

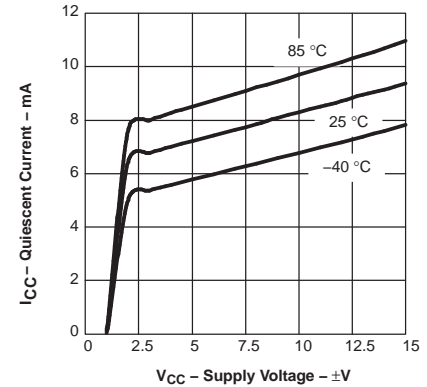

Figure 28. Quiescent Current vs Supply Voltage

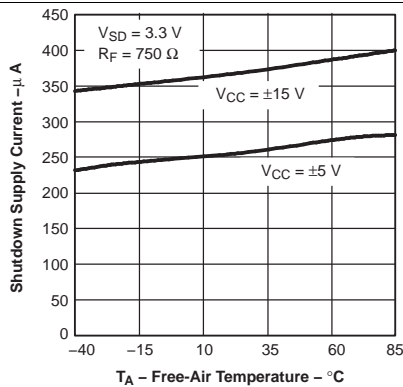

Figure 29. Shutdown Supply Current vs Free-Air Temperature

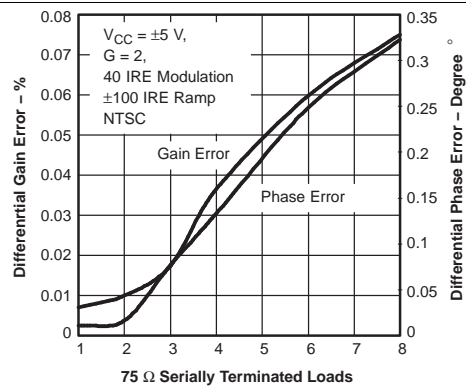
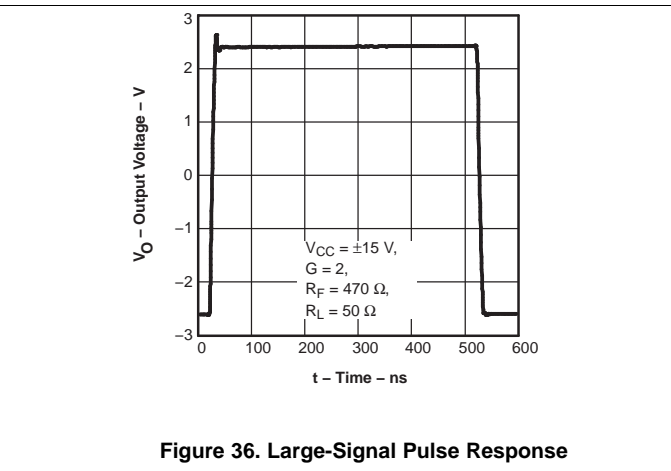
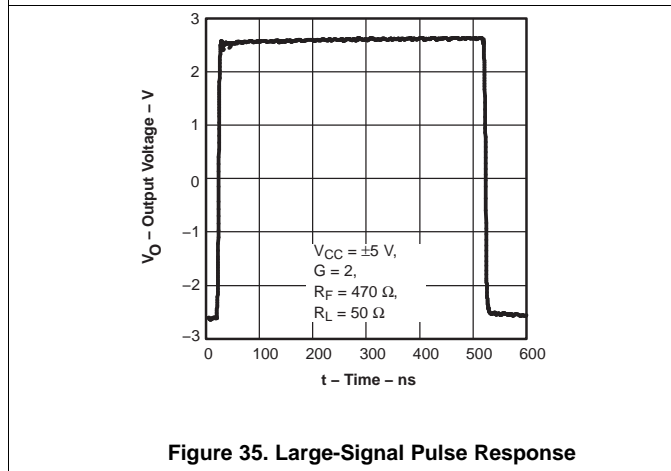
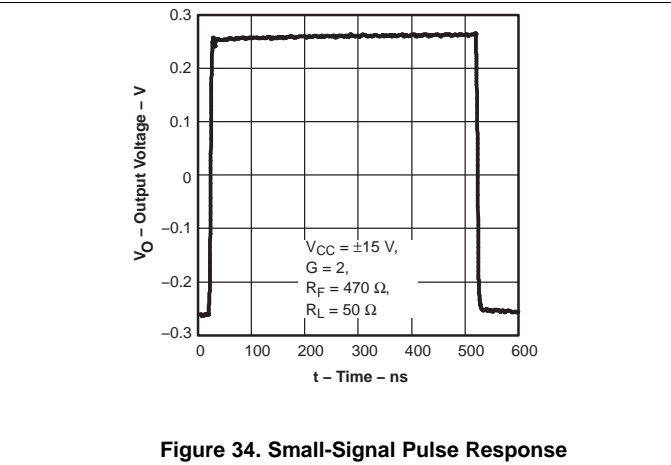
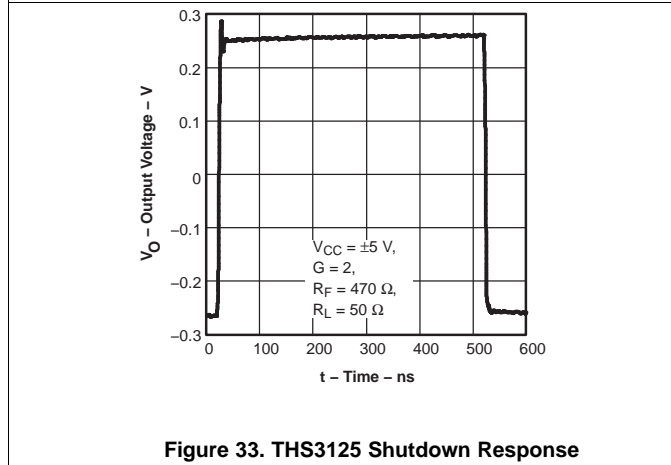
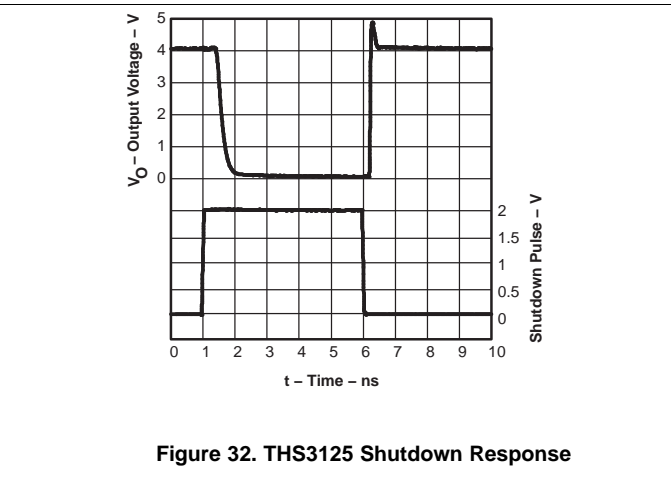
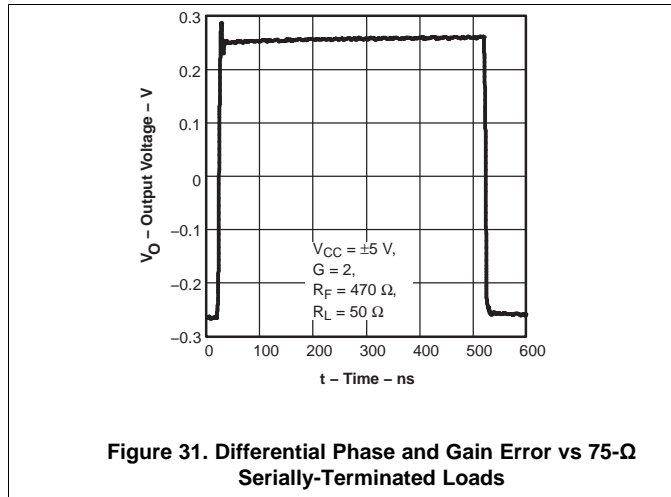

Figure 30. Differential Phase and Gain Error vs 75-Ω Serially-Terminated Loads

Typical Characteristics (continued)



## 8 Detailed Description

### 8.1 Overview

The THS3122 and THS3125 family of dual-channels, bipolar-input, high-speed current feedback amplifiers offers a low-noise of  $2.2 \text{ nV}/\sqrt{\text{Hz}}$  with a high output current drive of 450 mA. This performance is ideal for any application that requires low distortion over a wide range of frequencies with heavy loads.

### 8.2 Feature Description

#### 8.2.1 Maximum Slew Rate For Repetitive Signals

The THS3125 and THS3122 are recommended for high slew rate pulsed applications where the internal nodes of the amplifier have time to stabilize between pulses. It is recommended to have at least 20-ns delay between pulses.

The THS3125 and THS3122 are not recommended for applications with repetitive signals (sine, square, sawtooth, or other) that exceed  $900 \text{ V}/\mu\text{s}$ . Using the part in these applications results in excessive current draw from the power supply and possible device damage.

For applications with high slew rate, repetitive signals, the [THS3091](#) and [THS3095](#) (single versions), or [THS3092](#) and [THS3096](#) (dual versions) are recommended.

#### 8.2.2 Saving Power with Shutdown Functionality and Setting Threshold Levels with the Reference Pin

The THS3125 features a shutdown pin (SHUTDOWN) that lowers the quiescent current from 8.4 mA/amp down to  $370 \mu\text{A}/\text{amp}$ , ideal for reducing system power.

The shutdown pin of the amplifier defaults to the REF pin voltage in the absence of an applied voltage, putting the amplifier in the normal on mode of operation. To turn off the amplifier in an effort to conserve power, the shutdown pin can be driven towards the positive rail. The threshold voltages for power-on and power-down (or shutdown) are relative to the supply rails and are given in the [Electrical Characteristics: Shutdown Characteristics \(THS3125 Only\)](#) table. Below the *Enable* threshold voltage, the device is on. Above the *Disable* threshold voltage, the device is off. Behavior between these threshold voltages is not specified.

Note that this shutdown functionality is self-defining: the amplifier consumes less power in shutdown mode. The shutdown mode is not intended to provide a high-impedance output. In other words, the shutdown functionality is not intended to allow use as a 3-state bus driver. When in shutdown mode, the impedance looking back into the output of the amplifier is dominated by the feedback and gain setting resistors, but the output impedance of the device itself varies depending on the voltage applied to the outputs.

As with most current feedback amplifiers, the internal architecture places some limitations on the system when in shutdown mode. Most notably is the fact that the amplifier actually turns *on* if there is a  $\pm 0.7 \text{ V}$  or greater difference between the two input nodes (IN+ and IN-) of the amplifier. If this difference exceeds  $\pm 0.7 \text{ V}$ , the output of the amplifier creates an output voltage equal to approximately  $[(\text{IN}+ - \text{IN}-) - 0.7\text{V}] \times \text{Gain}$ . Also, if a voltage is applied to the output while in shutdown mode, the IN- node voltage is equal to  $V_{\text{O}(\text{applied})} \times R_{\text{G}} / (R_{\text{F}} + R_{\text{G}})$ . For low gain configurations and a large applied voltage at the output, the amplifier may actually turn on because of the behavior described here.

The time delays associated with turning the device on and off are specified as the time it takes for the amplifier to reach either 10% or 90% of the final output voltage. The time delays are in the order of microseconds because the amplifier moves in and out of the linear mode of operation in these transitions.

## Feature Description (continued)

### 8.2.3 Power-Down Reference Pin Operation

In addition to the shutdown pin, the THS3125 features a reference pin (REF) which allows the user to control the enable or disable power-down voltage levels applied to the SHUTDOWN pin. In most split-supply applications, the reference pin is connected to ground. In either case, the user must be aware of voltage-level thresholds that apply to the shutdown pin. [Table 1](#) shows examples and illustrate the relationship between the reference voltage and the power-down thresholds. In the table, the threshold levels are derived by the following equations:

$$\text{SHUTDOWN} \leq \text{REF} + 0.8 \text{ V for enable}$$

$$\text{SHUTDOWN} \geq \text{REF} + 2\text{V for disable}$$

Where the usable range at the REF pin is:

$$V_{\text{CC-}} \leq V_{\text{REF}} \leq (V_{\text{CC+}} - 4\text{V})$$

The recommended mode of operation is to tie the REF pin to midrail, therefore setting the enable/disable thresholds to  $V_{(\text{midrail})} + 0.8 \text{ V}$  and  $V_{(\text{midrail})} = 2 \text{ V}$ , respectively.

**Table 1. Shutdown Threshold Voltage Levels**

SUPPLY VOLTAGE (V)	REFERENCE PIN VOLTAGE (V)	ENABLE LEVEL (V)	DISABLE LEVEL (V)
±15, ±5	0	0.8	2.0
±15	2.0	2.8	4.0
±15	-2.0	-1.2	0
±5	1.0	1.8	3.0
±5	-1.0	-0.2	1.0
+30	15.0	15.8	17
+10	5.0	5.8	7.0

Note that if the REF pin is left unterminated, it floats to the positive rail and falls outside of the recommended operating range given above  $V_{\text{CC-}} \leq V_{\text{REF}} \leq (V_{\text{CC+}} - 4\text{V})$ . As a result, it no longer serves as a reliable reference for the SHUTDOWN pin, and the enable/disable thresholds given above no longer apply. If the SHUTDOWN pin is also left unterminated, it floats to the positive rail and the device is disabled. If balanced, split supplies are used ( $\pm V_S$ ) and the REF and SHUTDOWN pins are grounded, the device is enabled.

### 8.3 Device Functional Modes

#### 8.3.1 Wideband, Noninverting Operation

The THS3125 and THS3122 are unity gain stable 130-MHz current-feedback operational amplifiers, designed to operate from a  $\pm 5\text{-V}$  to  $\pm 15\text{-V}$  power supply.

Figure 37 shows the THS3125 in a noninverting gain of 2-V/V configuration used to generate the typical characteristic curves. Most of the curves were characterized using signal sources with 50- $\Omega$  source impedance and with measurement equipment that presents a 50- $\Omega$  load impedance.

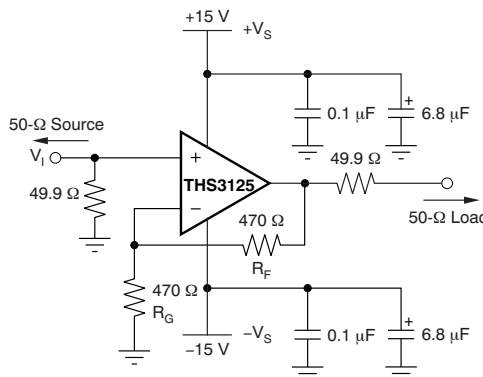

Figure 37. Wideband, Noninverting Gain Configuration

Current-feedback amplifiers are highly dependent on the feedback resistor  $R_F$  for maximum performance and stability. Table 2 shows the optimal gain setting resistors  $R_F$  and  $R_G$  at different gains to give maximum bandwidth with minimal peaking in the frequency response. Higher bandwidths can be achieved, at the expense of added peaking in the frequency response, by using even lower values for  $R_F$ . Conversely, increasing  $R_F$  decreases the bandwidth, but stability is improved.

Table 2. Recommended Resistor Values For Optimum Frequency Response

THS3125 and THS3122 $R_F$ and $R_G$ VALUES FOR MINIMAL PEAKING WITH $R_L = 50 \Omega$ , $\pm 5\text{-V}$ to $\pm 15\text{-V}$ POWER SUPPLY		
GAIN (V/V)	$R_G$ ( $\Omega$ )	$R_F$ ( $\Omega$ )
1	—	560
2	470	470
4	66.5	200

#### 8.3.2 Wideband, Inverting Operation

Figure 38 shows the THS3125 in a typical inverting gain configuration where the input and output impedances from Figure 37 are retained in an inverting circuit configuration.

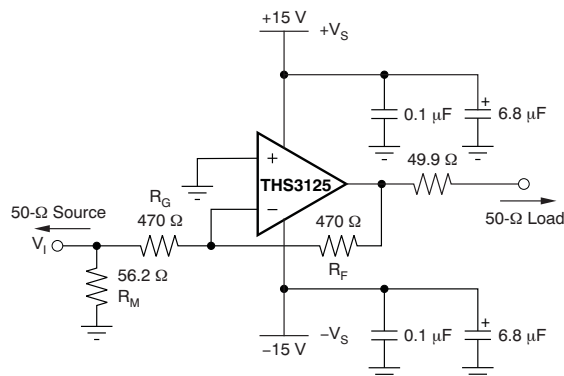

Figure 38. Wideband, Inverting Gain Configuration

### 8.3.3 Single-Supply Operation

The THS3125 and THS3122 have the capability to operate from a single supply voltage ranging from 10 V to 30 V. When operating from a single power supply, biasing the input and output at mid-supply allows for the maximum output voltage swing. The circuits in Figure 39 show inverting and noninverting amplifiers configured for single-supply operation.

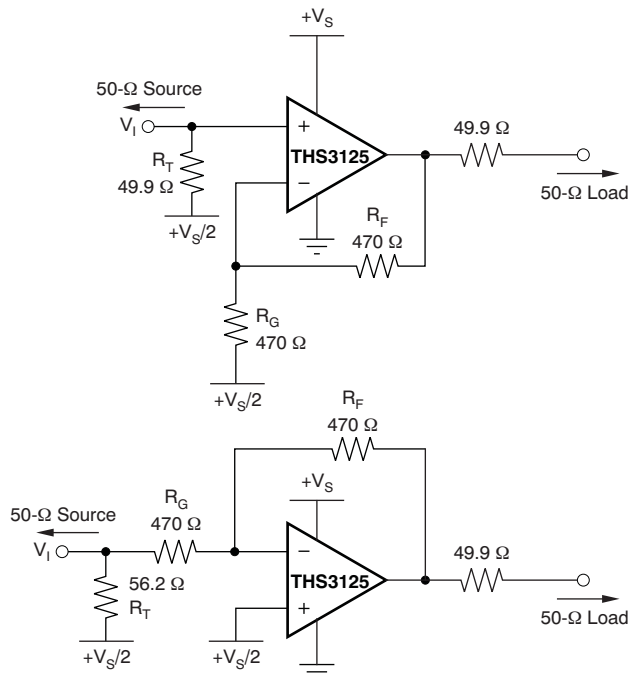

Figure 39. DC-Coupled, Single-Supply Operation

## 9 Application and Implementation

### NOTE

Information in the following applications sections is not part of the TI component specification, and TI does not warrant its accuracy or completeness. TI's customers are responsible for determining suitability of components for their purposes. Customers should validate and test their design implementation to confirm system functionality.

### 9.1 Application Information

#### 9.1.1 Video Distribution

The wide bandwidth, high slew rate, and high output drive current of the THS3125 and THS3122 match the demands for video distribution to deliver video signals down multiple cables. To ensure high signal quality with minimal degradation of performance, a 0.1-dB gain flatness should be at least 7x the passband frequency to minimize group delay variations from the amplifier. A high slew rate minimizes distortion of the video signal, and supports component video and RGB video signals that require fast transition times and fast settling times for high signal quality. [Figure 40](#) illustrates a typical video distribution amplifier application configuration.

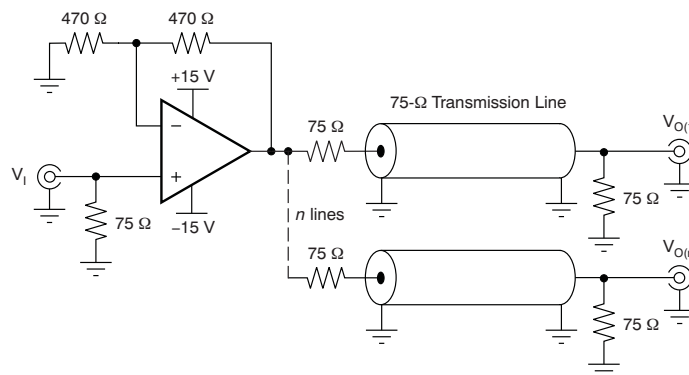
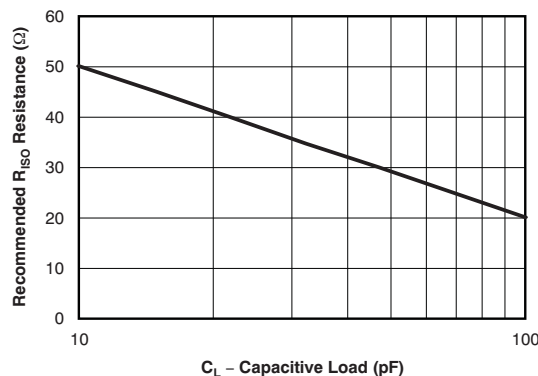

**Figure 40. Video Distribution Amplifier Application**

#### 9.1.2 Driving Capacitive Loads

Applications such as FET drivers and line drivers can be highly capacitive and cause stability problems for high-speed amplifiers.

[Figure 41](#) through [Figure 47](#) show recommended methods for driving capacitive loads. The basic idea is to use a resistor or ferrite chip to isolate the phase shift at high frequency caused by the capacitive load from the amplifier feedback path. See [Figure 41](#) for recommended resistor values versus capacitive load.



**Figure 41. Recommended R<sub>ISO</sub> vs Capacitive Load**

## Application Information (continued)

Placing a small series resistor,  $R_{ISO}$ , between the amplifier output and the capacitive load, as shown in Figure 42, is an easy way of isolating the load capacitance.

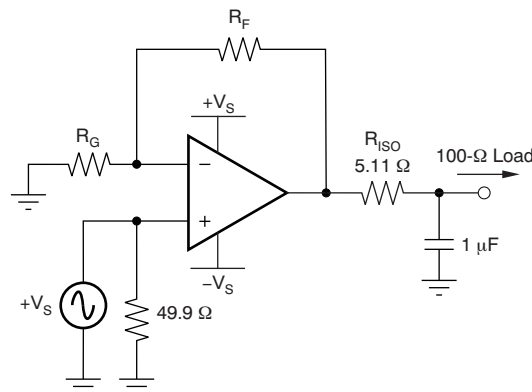

Figure 42. Resistor To Isolate Capacitive Load

Using a ferrite chip in place of  $R_{ISO}$ , as Figure 43 shows, is another approach of isolating the output of the amplifier. The ferrite impedance characteristic versus frequency is useful to maintain the low frequency load independence of the amplifier while isolating the phase shift caused by the capacitance at high frequency. Use a ferrite with similar impedance to  $R_{ISO}$ ,  $20\ \Omega$  to  $50\ \Omega$ , at  $100\ \text{MHz}$  and low impedance at dc.

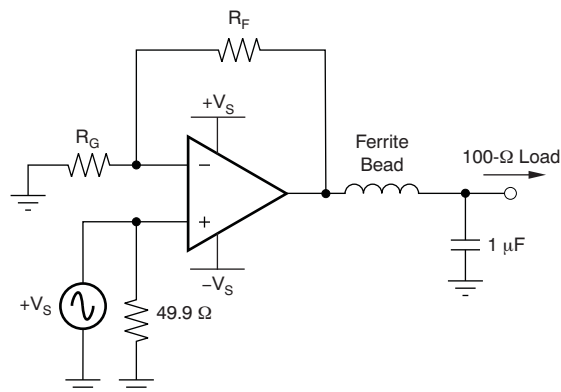

Figure 43. Ferrite Bead To Isolate Capacitive Load

Figure 44 shows another method used to maintain the low-frequency load independence of the amplifier while isolating the phase shift caused by the capacitance at high frequency. At low frequency, feedback is mainly from the load side of  $R_{ISO}$ . At high frequency, the feedback is mainly via the  $27\text{-pF}$  capacitor. The resistor  $R_{IN}$  in series with the negative input is used to stabilize the amplifier and should be equal to the recommended value of  $R_F$  at unity gain. Replacing  $R_{IN}$  with a ferrite of similar impedance at about  $100\ \text{MHz}$  as shown in Figure 45 gives similar results with reduced dc offset and low frequency noise.

Application Information (continued)

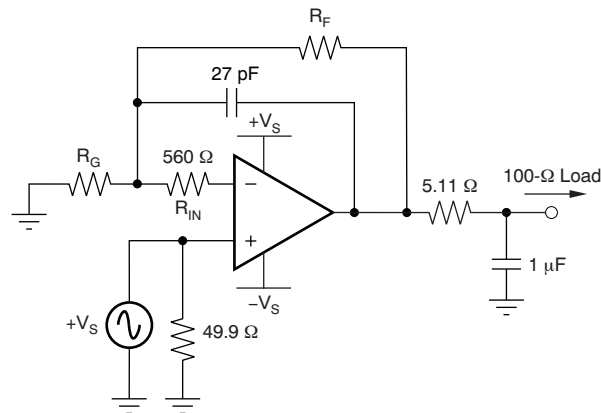

Figure 44. Feedback Technique With Input Resistor For Capacitive Load

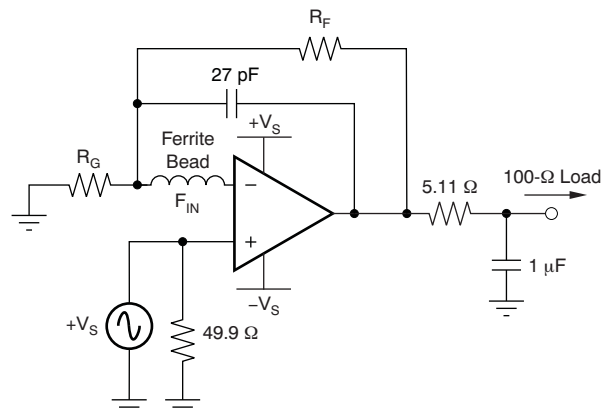
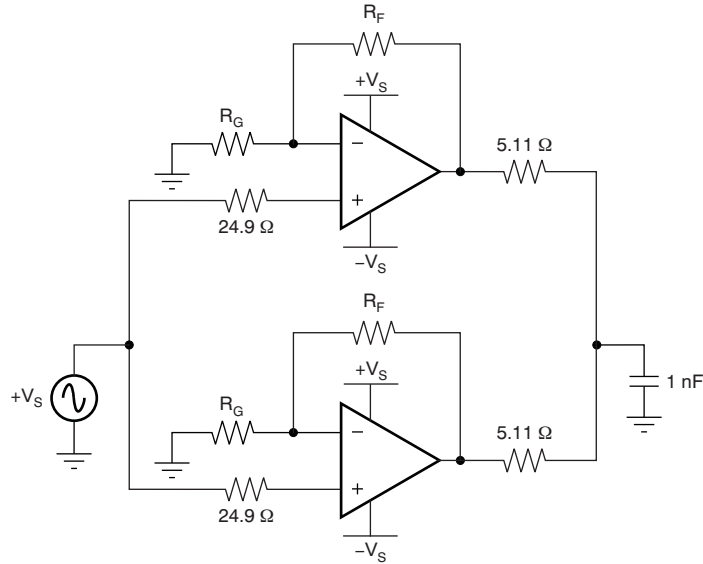

Figure 45. Feedback Technique With Input Ferrite Bead For Capacitive Load

**Application Information (continued)**

Figure 46 shows a configuration that uses two amplifiers in parallel to double the output drive current to larger capacitive loads. This technique is used when more output current is needed to charge and discharge the load faster as when driving large FET transistors.



**Figure 46. Parallel Amplifiers For Higher Output Drive**

Figure 47 shows a push-pull FET driver circuit typical of ultrasound applications with isolation resistors to isolate the gate capacitance from the amplifier.

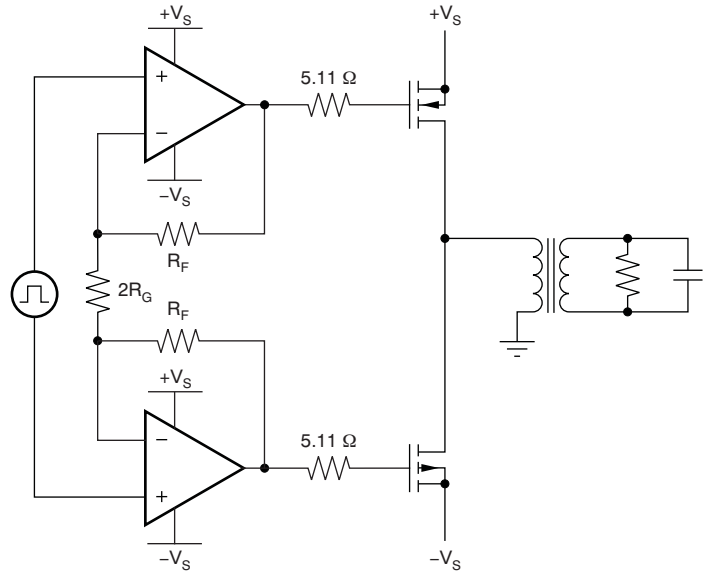

**Figure 47. Powerfet Drive Circuit**

## 10 Layout

### 10.1 Layout Guidelines

#### 10.1.1 Printed-Circuit Board Layout Techniques For Optimal Performance

Achieving optimum performance with high-frequency amplifiers such as the THS3125 and THS3122 requires careful attention to board layout parasitic and external component types. Recommendations that optimize performance include:

- Minimize parasitic capacitance to any ac ground for all of the signal I/O pins. Parasitic capacitance on the output and input pins can cause instability. To reduce unwanted capacitance, a window around the signal I/O pins should be opened in all of the ground and power planes around those pins. Otherwise, ground and power planes should be unbroken elsewhere on the board.
- Minimize the distance [0.25 inch, (6,4 mm)] from the power-supply pins to high-frequency 0.1- $\mu$ F and 100-pF decoupling capacitors. At the device pins, the ground and power plane layout should not be in close proximity to the signal I/O pins. Avoid narrow power and ground traces to minimize inductance between the pins and the decoupling capacitors. The power-supply connections should always be decoupled with these capacitors. Larger (6.8  $\mu$ F or more) tantalum decoupling capacitors, effective at lower frequencies, should also be used on the main supply pins. These capacitors may be placed somewhat farther from the device and may be shared among several devices in the same area of the printed circuit board (PCB).
- Careful selection and placement of external components preserve the high-frequency performance of the THS3125 and THS3122. Resistors should be a very low reactance type. Surface-mount resistors work best and allow a tighter overall layout. Again, keep the leads and PCB trace length as short as possible. Never use wirebound type resistors in a high-frequency application. Because the output pin and inverting input pins are the most sensitive to parasitic capacitance, always position the feedback and series output resistors, if any, as close as possible to the inverting input pins and output pins. Other network components, such as input termination resistors, should be placed close to the gain-setting resistors. Even with a low parasitic capacitance that shunts the external resistors, excessively high resistor values can create significant time constants that can degrade performance. Good axial metal-film or surface-mount resistors have approximately 0.2 pF in shunt with the resistor. For resistor values greater than 2.0 k $\Omega$ , this parasitic capacitance can add a pole and/or a zero that can affect circuit operation. Keep resistor values as low as possible, consistent with load driving considerations.
- Connections to other wideband devices on the board may be made with short direct traces or through onboard transmission lines. For short connections, consider the trace and the input to the next device as a lumped capacitive load. Relatively wide traces [0.05 inch (1,3 mm) to 0.1 inch (2,54 mm)] should be used, preferably with ground and power planes opened up around them. Estimate the total capacitive load and determine if isolation resistors on the outputs are necessary. Low parasitic capacitive loads (less than 4 pF) may not need an  $R_S$  because the THS3125 and THS3122 are nominally compensated to operate with a 2-pF parasitic load. Higher parasitic capacitive loads without an  $R_S$  are allowed as the signal gain increases (thus increasing the unloaded phase margin). If a long trace is required, and the 6-dB signal loss intrinsic to a doubly-terminated transmission line is acceptable, implement a matched-impedance transmission line using microstrip or stripline techniques (consult an ECL design handbook for microstrip and stripline layout techniques). A 50- $\Omega$  environment is not necessary onboard, and in fact, a higher impedance environment improves distortion as shown in the distortion versus load plots. With a characteristic board trace impedance based on board material and trace dimensions, a matching series resistor into the trace from the output of the THS3125/THS3122 is used as well as a terminating shunt resistor at the input of the destination device. Remember also that the terminating impedance is the parallel combination of the shunt resistor and the input impedance of the destination device: this total effective impedance should be set to match the trace impedance. If the 6-dB attenuation of a doubly-terminated transmission line is unacceptable, a long trace can be series-terminated at the source end only. Treat the trace as a capacitive load in this case. This configuration does not preserve signal integrity as well as a doubly-terminated line. If the input impedance of the destination device is low, there is some signal attenuation as a result of the voltage divider formed by the series output into the terminating impedance.
- Socketing a high-speed device such as the THS3125 and THS3122 is not recommended. The additional lead length and pin-to-pin capacitance introduced by the socket can create an extremely troublesome parasitic network which can make it almost impossible to achieve a smooth, stable frequency response. Best results are obtained by soldering the THS3125/THS3122 amplifiers directly onto the board.

## Layout Guidelines (continued)

### 10.1.2 PowerPAD Design Considerations

The THS3125 and THS3122 are available in a thermally-enhanced PowerPAD family of packages. These packages are constructed using a downset leadframe upon which the die is mounted [see [Figure 48\(a\)](#) and [Figure 48\(b\)](#)]. This arrangement results in the lead frame being exposed as a thermal pad on the underside of the package [see [Figure 48\(c\)](#)]. Because this thermal pad has direct thermal contact with the die, excellent thermal performance can be achieved by providing a good thermal path away from the thermal pad. Note that devices such as the THS312x have no electrical connection between the PowerPAD and the die.

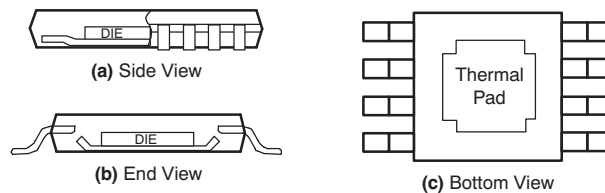

**Figure 48. Views Of Thermally-Enhanced Package**

The PowerPAD package allows for both assembly and thermal management in one manufacturing operation. During the surface-mount solder operation (when the leads are being soldered), the thermal pad can also be soldered to a copper area underneath the package. Through the use of thermal paths within this copper area, heat can be conducted away from the package into either a ground plane or other heat dissipating device.

The PowerPAD package represents a breakthrough in combining the small area and ease of assembly of surface mount with the, heretofore, awkward mechanical methods of heatsinking.

## Layout Guidelines (continued)

### 10.1.3 PowerPAD Layout Considerations

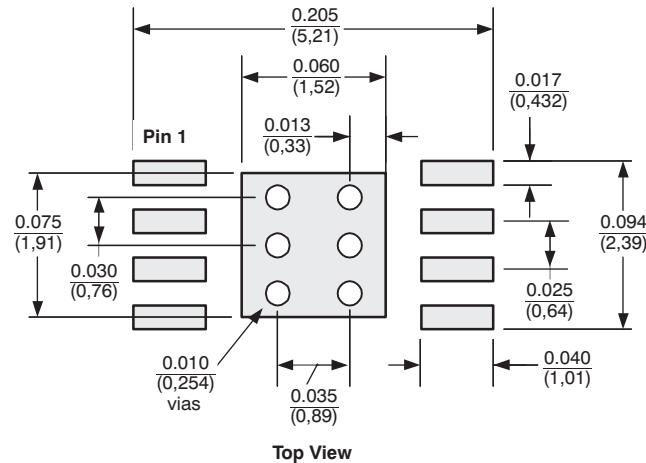

Dimensions are in inches (millimeters).

**Figure 49. DGN PowerPAD PCB Etch and Via Pattern**

Although there are many ways to properly heatsink the PowerPAD package, the following steps illustrate the recommended approach.

1. PCB with a top side etch pattern as shown in [Figure 49](#).
2. Place five holes in the area of the thermal pad. These holes should be 0.01 inch (0,254 mm) in diameter. Keep them small so that solder wicking through the holes is not a problem during reflow.
3. Additional vias may be placed anywhere along the thermal plane outside of the thermal pad area. These vias help dissipate the heat generated by the THS3125/THS3122 IC. These additional vias may be larger than the 0.01-inch (0,254-mm) diameter vias directly under the thermal pad. They can be larger because they are not in the thermal pad area to be soldered so that wicking is not a problem.
4. Connect all holes to the internal ground plane. Note that the PowerPAD is electrically isolated from the silicon and all leads. Connecting the PowerPAD to any potential voltage, such as  $V_{S-}$ , is acceptable as there is no electrical connection to the silicon.
5. When connecting these holes to the ground plane, do not use the typical web or spoke via connection methodology. Web connections have a high thermal resistance connection that is useful for slowing the heat transfer during soldering operations. This resistance makes the soldering of vias that have plane connections easier. In this application; however, low thermal resistance is desired for the most efficient heat transfer. Therefore, the holes under the THS3125/THS3122 PowerPAD package should make the connection to the internal ground plane with a complete connection around the entire circumference of the plated-through hole.
6. The top-side solder mask should leave the terminals of the package and the thermal pad area with its five holes exposed. The bottom-side solder mask should cover the five holes of the thermal pad area. This configuration prevents solder from being pulled away from the thermal pad area during the reflow process.
7. Apply solder paste to the exposed thermal pad area and all of the IC terminals.
8. With these preparatory steps in place, the IC is simply placed in position and run through the solder reflow operation as any standard surface-mount component. This procedure results in a part that is properly installed.

## Layout Guidelines (continued)

### 10.1.4 Power Dissipation And Thermal Considerations

The THS3125 and THS3122 incorporate automatic thermal shutoff protection. This protection circuitry shuts down the amplifier if the junction temperature exceeds approximately +160°C. When the junction temperature reduces to approximately +140°C, the amplifier turns on again. However, for maximum performance and reliability, the designer must take care to ensure that the design does not exceed a junction temperature of +125°C. Between +125°C and +150°C, damage does not occur, but the performance of the amplifier begins to degrade and long-term reliability suffers. The thermal characteristics of the device are dictated by the package and the PCB. Maximum power dissipation for a given package can be calculated using the following formula.

$$P_{DMax} = \frac{T_{max} - T_A}{\theta_{JA}}$$

where:

- $P_{DMax}$  is the maximum power dissipation in the amplifier (W)
- $T_{max}$  is the absolute maximum junction temperature (°C)
- $T_A$  is the ambient temperature (°C)

$$\theta_{JA} = \theta_{JC} + \theta_{CA}$$

where:

- $\theta_{JC}$  is the thermal coefficient from the silicon junctions to the case (°C/W)
- $\theta_{CA}$  is the thermal coefficient from the case to ambient air (°C/W)

For systems where heat dissipation is more critical, the THS3125 and THS3122 are also available in an 8-pin MSOP with PowerPAD package that offers even better thermal performance. The thermal coefficient for the PowerPAD packages are substantially improved over the traditional SOIC. Maximum power dissipation levels are depicted in [Figure 50](#) for the available packages. The data for the PowerPAD packages assume a board layout that follows the PowerPAD layout guidelines discussed above and detailed in the PowerPAD application note (literature number [SLMA002](#)). [Figure 50](#) also illustrates the effect of not soldering the PowerPAD to a PCB. The thermal impedance increases substantially, which may cause serious heat and performance issues. Always solder the PowerPAD to the PCB for optimum performance.

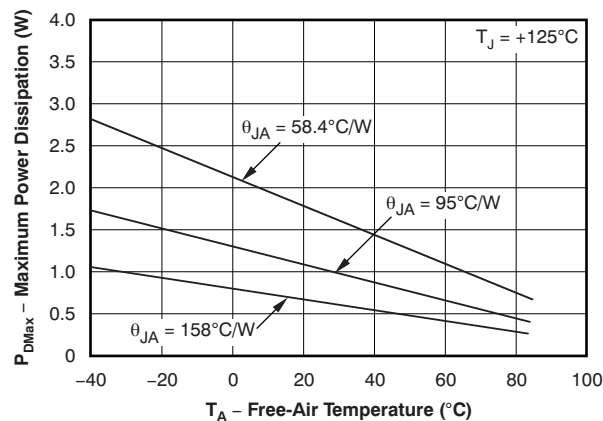

Results shown are with no air flow and PCB size of 3 in x 3 in (76,2 mm x 76,2 mm).

- $\theta_{JA} = 58.4^\circ\text{C/W}$  for 8-pin MSOP with PowerPAD (DGN package)
- $\theta_{JA} = 95^\circ\text{C/W}$  for 8-pin SOIC High-K test PCB (D package)
- $\theta_{JA} = 158^\circ\text{C/W}$  for 8-pin MSOP with PowerPAD without solder

**Figure 50. Maximum Power Dissipation vs Ambient Temperature**

When determining whether or not the device satisfies the maximum power dissipation requirement, it is important to not only consider quiescent power dissipation, but also dynamic power dissipation. Often times, this type of dissipation is difficult to quantify because the signal pattern is inconsistent, but an estimate of the RMS power dissipation can provide visibility into a possible problem.

## 11 Device and Documentation Support

### 11.1 Related Links

[Table 3](#) lists quick access links. Categories include technical documents, support and community resources, tools and software, and quick access to sample or buy.

**Table 3. Related Links**

PARTS	PRODUCT FOLDER	SAMPLE & BUY	TECHNICAL DOCUMENTS	TOOLS & SOFTWARE	SUPPORT & COMMUNITY
THS3122	<a href="#">Click here</a>	<a href="#">Click here</a>	<a href="#">Click here</a>	<a href="#">Click here</a>	<a href="#">Click here</a>
THS3125	<a href="#">Click here</a>	<a href="#">Click here</a>	<a href="#">Click here</a>	<a href="#">Click here</a>	<a href="#">Click here</a>

### 11.2 Community Resources

The following links connect to TI community resources. Linked contents are provided "AS IS" by the respective contributors. They do not constitute TI specifications and do not necessarily reflect TI's views; see TI's [Terms of Use](#).

**TI E2E™ Online Community** *TI's Engineer-to-Engineer (E2E) Community*. Created to foster collaboration among engineers. At [e2e.ti.com](http://e2e.ti.com), you can ask questions, share knowledge, explore ideas and help solve problems with fellow engineers.

**Design Support** *TI's Design Support* Quickly find helpful E2E forums along with design support tools and contact information for technical support.

### 11.3 Trademarks

PowerPAD, E2E are trademarks of Texas Instruments.  
All other trademarks are the property of their respective owners.

### 11.4 Electrostatic Discharge Caution



This integrated circuit can be damaged by ESD. Texas Instruments recommends that all integrated circuits be handled with appropriate precautions. Failure to observe proper handling and installation procedures can cause damage.

ESD damage can range from subtle performance degradation to complete device failure. Precision integrated circuits may be more susceptible to damage because very small parametric changes could cause the device not to meet its published specifications.

### 11.5 Glossary

[SLYZ022](#) — *TI Glossary*.

This glossary lists and explains terms, acronyms, and definitions.

## 12 Mechanical, Packaging, and Orderable Information

The following pages include mechanical, packaging, and orderable information. This information is the most current data available for the designated devices. This data is subject to change without notice and revision of this document. For browser-based versions of this data sheet, refer to the left-hand navigation.

**PACKAGING INFORMATION**

Orderable Device	Status (1)	Package Type	Package Drawing	Pins	Package Qty	Eco Plan (2)	Lead/Ball Finish (6)	MSL Peak Temp (3)	Op Temp (°C)	Device Marking (4/5)	Samples
THS3122CD	ACTIVE	SOIC	D	8	75	Green (RoHS & no Sb/Br)	CU NIPDAU	Level-1-260C-UNLIM	0 to 70	3122C	<a href="#">Samples</a>
THS3122CDDA	ACTIVE	SO PowerPAD	DDA	8	75	Green (RoHS & no Sb/Br)	CU SN	Level-1-260C-UNLIM	0 to 70	3122C	<a href="#">Samples</a>
THS3122ID	ACTIVE	SOIC	D	8	75	Green (RoHS & no Sb/Br)	CU NIPDAU	Level-1-260C-UNLIM	-40 to 85	3122I	<a href="#">Samples</a>
THS3122IDDA	ACTIVE	SO PowerPAD	DDA	8	75	Green (RoHS & no Sb/Br)	CU SN	Level-1-260C-UNLIM	-40 to 85	3122I	<a href="#">Samples</a>
THS3125CPWP	ACTIVE	HTSSOP	PWP	14	90	Green (RoHS & no Sb/Br)	CU NIPDAU	Level-2-260C-1 YEAR	0 to 70	HS3125C	<a href="#">Samples</a>
THS3125ID	ACTIVE	SOIC	D	14	50	Green (RoHS & no Sb/Br)	CU NIPDAU	Level-1-260C-UNLIM	-40 to 85	THS3125I	<a href="#">Samples</a>
THS3125IPWP	ACTIVE	HTSSOP	PWP	14	90	Green (RoHS & no Sb/Br)	CU NIPDAU	Level-2-260C-1 YEAR	-40 to 85	HS3125I	<a href="#">Samples</a>
THS3125IPWPR	ACTIVE	HTSSOP	PWP	14	2000	Green (RoHS & no Sb/Br)	CU NIPDAU	Level-2-260C-1 YEAR	-40 to 85	HS3125I	<a href="#">Samples</a>

(1) The marketing status values are defined as follows:

**ACTIVE:** Product device recommended for new designs.

**LIFEBUY:** TI has announced that the device will be discontinued, and a lifetime-buy period is in effect.

**NRND:** Not recommended for new designs. Device is in production to support existing customers, but TI does not recommend using this part in a new design.

**PREVIEW:** Device has been announced but is not in production. Samples may or may not be available.

**OBSELETE:** TI has discontinued the production of the device.

(2) **RoHS:** TI defines "RoHS" to mean semiconductor products that are compliant with the current EU RoHS requirements for all 10 RoHS substances, including the requirement that RoHS substance do not exceed 0.1% by weight in homogeneous materials. Where designed to be soldered at high temperatures, "RoHS" products are suitable for use in specified lead-free processes. TI may reference these types of products as "Pb-Free".

**RoHS Exempt:** TI defines "RoHS Exempt" to mean products that contain lead but are compliant with EU RoHS pursuant to a specific EU RoHS exemption.

**Green:** TI defines "Green" to mean the content of Chlorine (Cl) and Bromine (Br) based flame retardants meet JS709B low halogen requirements of <=1000ppm threshold. Antimony trioxide based flame retardants must also meet the <=1000ppm threshold requirement.

(3) MSL, Peak Temp. - The Moisture Sensitivity Level rating according to the JEDEC industry standard classifications, and peak solder temperature.

(4) There may be additional marking, which relates to the logo, the lot trace code information, or the environmental category on the device.

<sup>(5)</sup> Multiple Device Markings will be inside parentheses. Only one Device Marking contained in parentheses and separated by a "-" will appear on a device. If a line is indented then it is a continuation of the previous line and the two combined represent the entire Device Marking for that device.

<sup>(6)</sup> Lead/Ball Finish - Orderable Devices may have multiple material finish options. Finish options are separated by a vertical ruled line. Lead/Ball Finish values may wrap to two lines if the finish value exceeds the maximum column width.

**Important Information and Disclaimer:**The information provided on this page represents TI's knowledge and belief as of the date that it is provided. TI bases its knowledge and belief on information provided by third parties, and makes no representation or warranty as to the accuracy of such information. Efforts are underway to better integrate information from third parties. TI has taken and continues to take reasonable steps to provide representative and accurate information but may not have conducted destructive testing or chemical analysis on incoming materials and chemicals. TI and TI suppliers consider certain information to be proprietary, and thus CAS numbers and other limited information may not be available for release.

In no event shall TI's liability arising out of such information exceed the total purchase price of the TI part(s) at issue in this document sold by TI to Customer on an annual basis.

## TAPE AND REEL INFORMATION



### QUADRANT ASSIGNMENTS FOR PIN 1 ORIENTATION IN TAPE



\*All dimensions are nominal

Device	Package Type	Package Drawing	Pins	SPQ	Reel Diameter (mm)	Reel Width W1 (mm)	A0 (mm)	B0 (mm)	K0 (mm)	P1 (mm)	W (mm)	Pin1 Quadrant
THS3125IPWPR	HTSSOP	PWP	14	2000	330.0	12.4	6.9	5.6	1.6	8.0	12.0	Q1

TAPE AND REEL BOX DIMENSIONS



\*All dimensions are nominal

Device	Package Type	Package Drawing	Pins	SPQ	Length (mm)	Width (mm)	Height (mm)
THS3125IPWPR	HTSSOP	PWP	14	2000	350.0	350.0	43.0

PWP (R-PDSO-G14)

PowerPAD™ PLASTIC SMALL OUTLINE

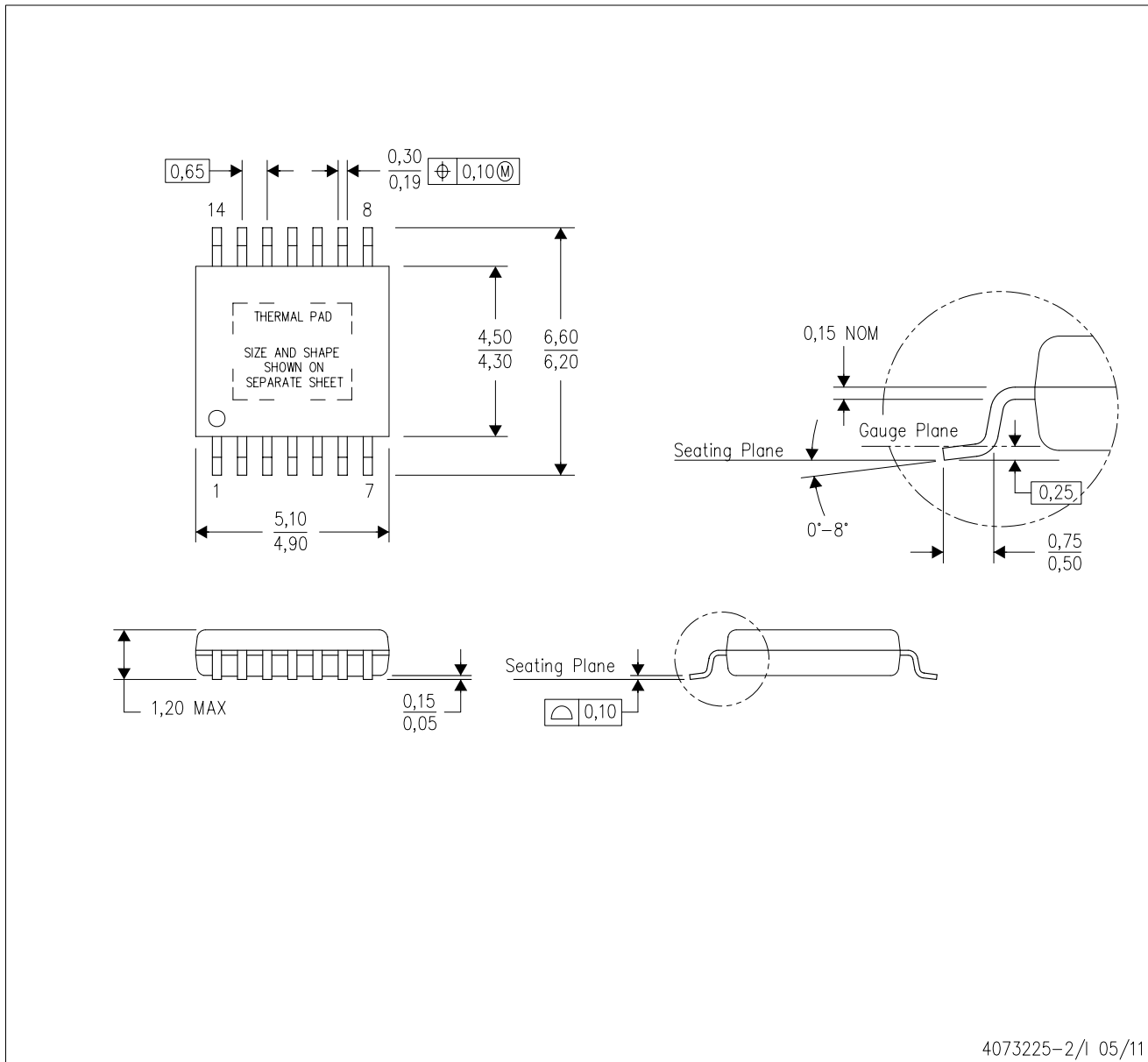

- NOTES:
- All linear dimensions are in millimeters.
  - This drawing is subject to change without notice.
  - Body dimensions do not include mold flash or protrusions. Mold flash and protrusion shall not exceed 0.15 per side.
  - This package is designed to be soldered to a thermal pad on the board. Refer to Technical Brief, PowerPad Thermally Enhanced Package, Texas Instruments Literature No. SLMA002 for information regarding recommended board layout. This document is available at [www.ti.com](http://www.ti.com) <<http://www.ti.com>>.
  - See the additional figure in the Product Data Sheet for details regarding the exposed thermal pad features and dimensions.
  - Falls within JEDEC MO-153

PowerPAD is a trademark of Texas Instruments.

## THERMAL PAD MECHANICAL DATA

PWP (R-PDSO-G14)

PowerPAD™ SMALL PLASTIC OUTLINE

### THERMAL INFORMATION

This PowerPAD™ package incorporates an exposed thermal pad that is designed to be attached to a printed circuit board (PCB). The thermal pad must be soldered directly to the PCB. After soldering, the PCB can be used as a heatsink. In addition, through the use of thermal vias, the thermal pad can be attached directly to the appropriate copper plane shown in the electrical schematic for the device, or alternatively, can be attached to a special heatsink structure designed into the PCB. This design optimizes the heat transfer from the integrated circuit (IC).

For additional information on the PowerPAD package and how to take advantage of its heat dissipating abilities, refer to Technical Brief, PowerPAD Thermally Enhanced Package, Texas Instruments Literature No. SLMA002 and Application Brief, PowerPAD Made Easy, Texas Instruments Literature No. SLMA004. Both documents are available at [www.ti.com](http://www.ti.com).

The exposed thermal pad dimensions for this package are shown in the following illustration.

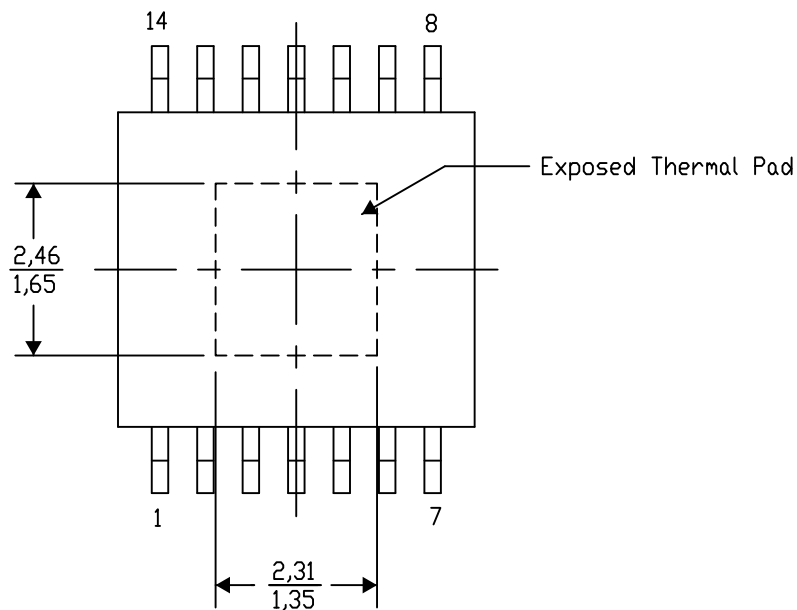

Top View

Exposed Thermal Pad Dimensions

4206332-2/AO 01/16

NOTE: A. All linear dimensions are in millimeters

PowerPAD is a trademark of Texas Instruments

PWP (R-PDSO-G14)

PowerPAD™ PLASTIC SMALL OUTLINE

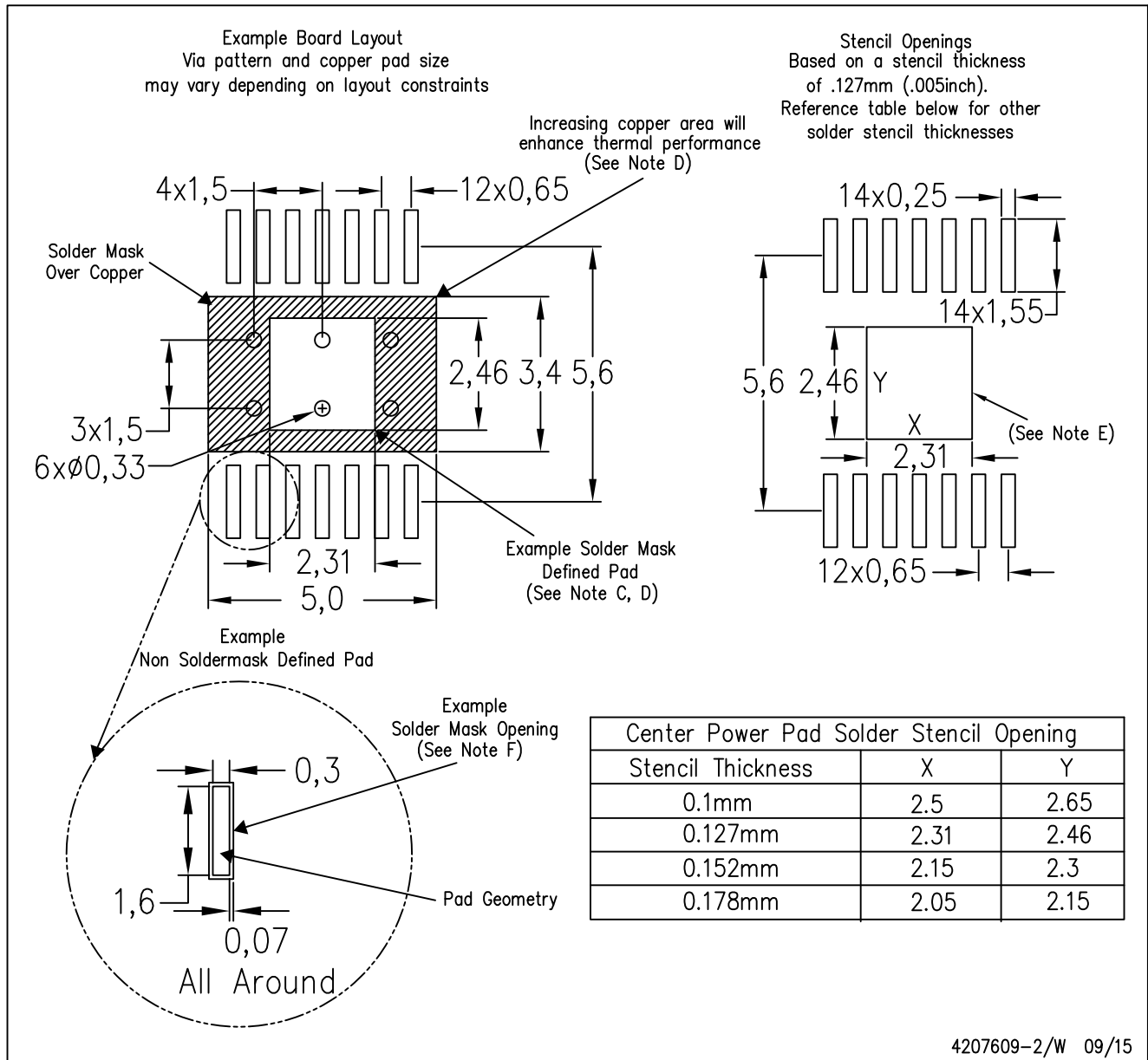

- NOTES:
- A. All linear dimensions are in millimeters.
  - B. This drawing is subject to change without notice.
  - C. Customers should place a note on the circuit board fabrication drawing not to alter the center solder mask defined pad.
  - D. This package is designed to be soldered to a thermal pad on the board. Refer to Technical Brief, PowerPAD Thermally Enhanced Package, Texas Instruments Literature No. SLMA002, SLMA004, and also the Product Data Sheets for specific thermal information, via requirements, and recommended board layout. These documents are available at [www.ti.com](http://www.ti.com) <<http://www.ti.com>>. Publication IPC-7351 is recommended for alternate designs.
  - E. Laser cutting apertures with trapezoidal walls and also rounding corners will offer better paste release. Customers should contact their board assembly site for stencil design recommendations. Example stencil design based on a 50% volumetric metal load solder paste. Refer to IPC-7525 for other stencil recommendations.
  - F. Customers should contact their board fabrication site for solder mask tolerances between and around signal pads.

# THERMAL PAD MECHANICAL DATA

PWP (R-PDSO-G14)

PowerPAD™ SMALL PLASTIC OUTLINE

## THERMAL INFORMATION

This PowerPAD™ package incorporates an exposed thermal pad that is designed to be attached to a printed circuit board (PCB). The thermal pad must be soldered directly to the PCB. After soldering, the PCB can be used as a heatsink. In addition, through the use of thermal vias, the thermal pad can be attached directly to the appropriate copper plane shown in the electrical schematic for the device, or alternatively, can be attached to a special heatsink structure designed into the PCB. This design optimizes the heat transfer from the integrated circuit (IC).

For additional information on the PowerPAD package and how to take advantage of its heat dissipating abilities, refer to Technical Brief, PowerPAD Thermally Enhanced Package, Texas Instruments Literature No. SLMA002 and Application Brief, PowerPAD Made Easy, Texas Instruments Literature No. SLMA004. Both documents are available at [www.ti.com](http://www.ti.com).

The exposed thermal pad dimensions for this package are shown in the following illustration.

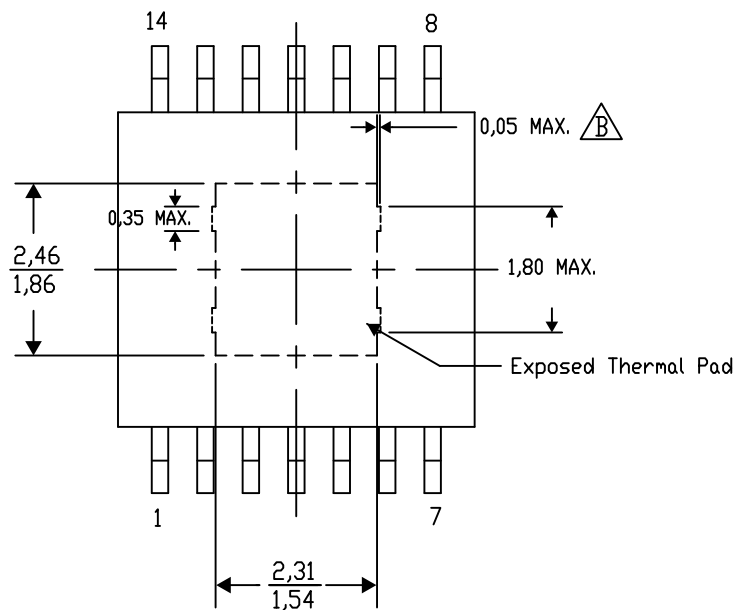

Top View

Exposed Thermal Pad Dimensions

4206332-44/AO 01/16

NOTE: A. All linear dimensions are in millimeters

 Exposed tie strap features may not be present.

PowerPAD is a trademark of Texas Instruments

PWP (R-PDSO-G14)

PowerPAD™ PLASTIC SMALL OUTLINE

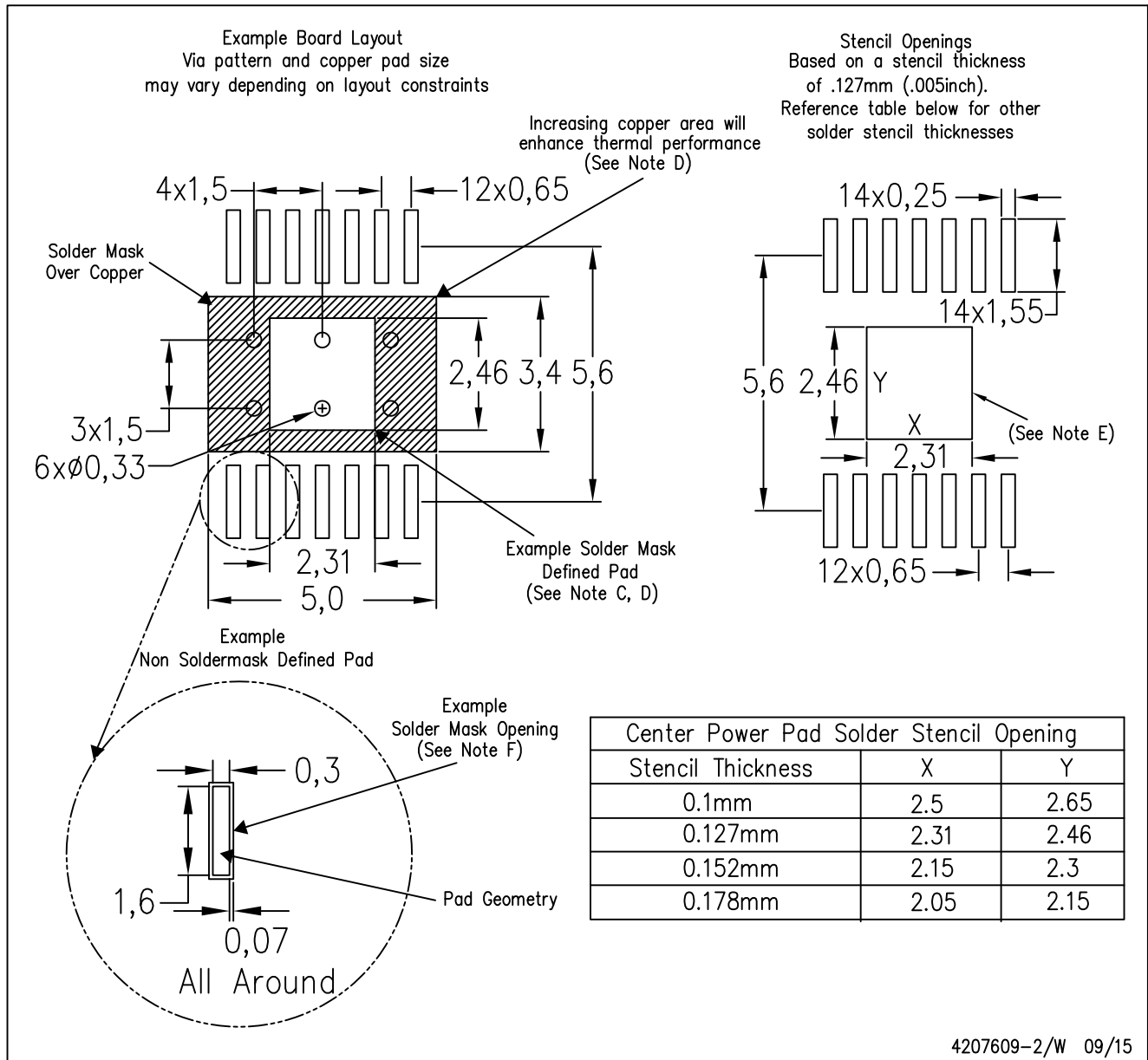

- NOTES:
- A. All linear dimensions are in millimeters.
  - B. This drawing is subject to change without notice.
  - C. Customers should place a note on the circuit board fabrication drawing not to alter the center solder mask defined pad.
  - D. This package is designed to be soldered to a thermal pad on the board. Refer to Technical Brief, PowerPAD Thermally Enhanced Package, Texas Instruments Literature No. SLMA002, SLMA004, and also the Product Data Sheets for specific thermal information, via requirements, and recommended board layout. These documents are available at [www.ti.com](http://www.ti.com) <<http://www.ti.com>>. Publication IPC-7351 is recommended for alternate designs.
  - E. Laser cutting apertures with trapezoidal walls and also rounding corners will offer better paste release. Customers should contact their board assembly site for stencil design recommendations. Example stencil design based on a 50% volumetric metal load solder paste. Refer to IPC-7525 for other stencil recommendations.
  - F. Customers should contact their board fabrication site for solder mask tolerances between and around signal pads.

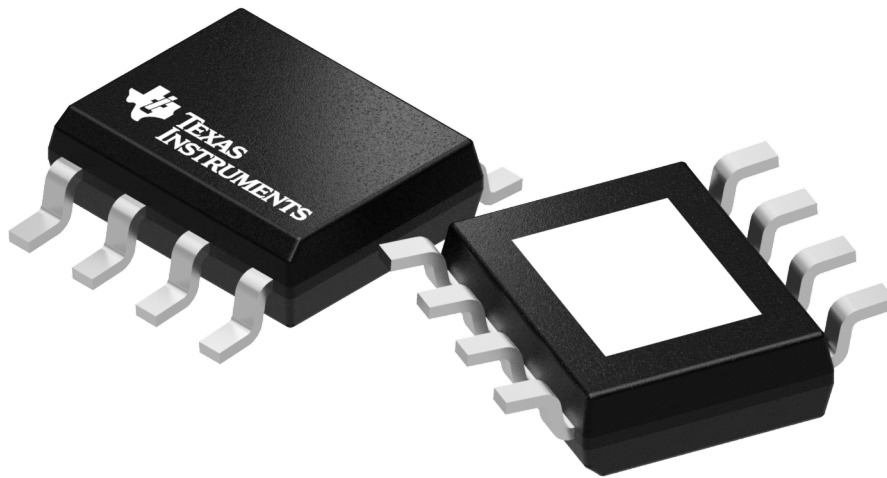

Images above are just a representation of the package family, actual package may vary.  
Refer to the product data sheet for package details.

# DDA0008B



# PACKAGE OUTLINE

## PowerPAD™ SOIC - 1.7 mm max height

PLASTIC SMALL OUTLINE

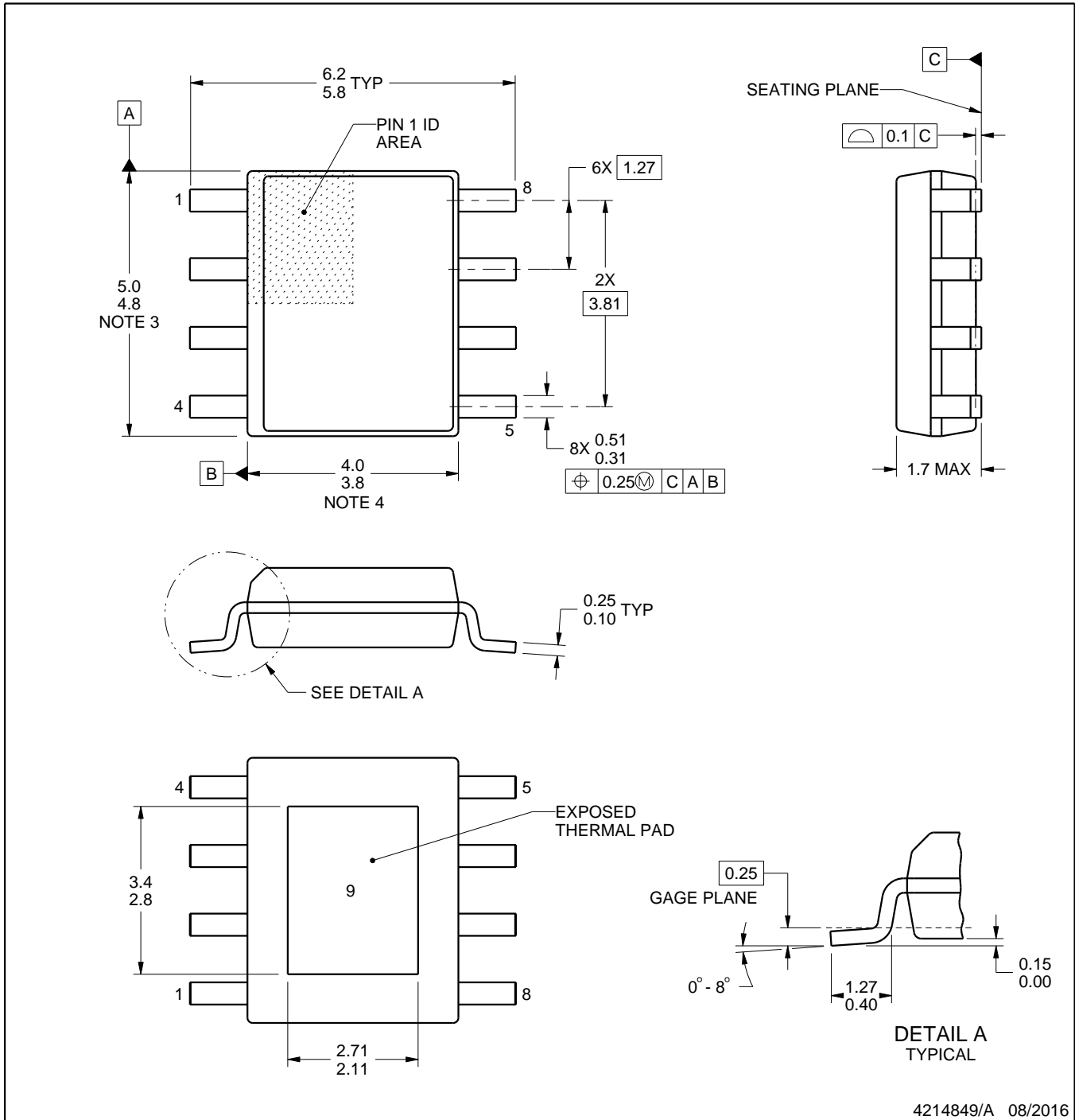

4214849/A 08/2016

### NOTES:

PowerPAD is a trademark of Texas Instruments.

1. All linear dimensions are in millimeters. Any dimensions in parenthesis are for reference only. Dimensioning and tolerancing per ASME Y14.5M.
2. This drawing is subject to change without notice.
3. This dimension does not include mold flash, protrusions, or gate burrs. Mold flash, protrusions, or gate burrs shall not exceed 0.15 mm per side.
4. This dimension does not include interlead flash. Interlead flash shall not exceed 0.25 mm per side.
5. Reference JEDEC registration MS-012.

# EXAMPLE BOARD LAYOUT

DDA0008B

PowerPAD™ SOIC - 1.7 mm max height

PLASTIC SMALL OUTLINE

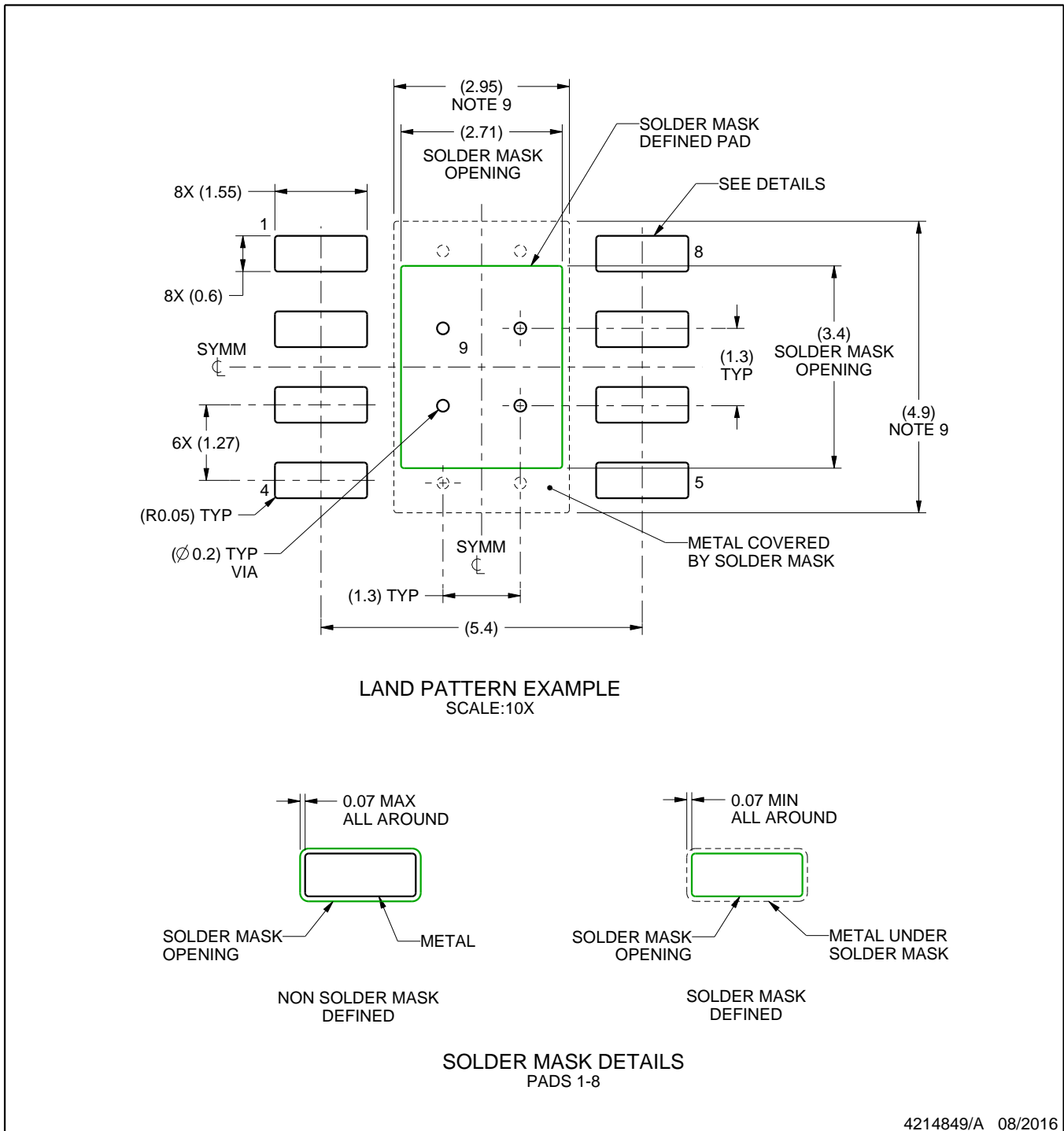

4214849/A 08/2016

NOTES: (continued)

6. Publication IPC-7351 may have alternate designs.
7. Solder mask tolerances between and around signal pads can vary based on board fabrication site.
8. This package is designed to be soldered to a thermal pad on the board. For more information, see Texas Instruments literature numbers SLMA002 ([www.ti.com/lit/slma002](http://www.ti.com/lit/slma002)) and SLMA004 ([www.ti.com/lit/slma004](http://www.ti.com/lit/slma004)).
9. Size of metal pad may vary due to creepage requirement.
10. Vias are optional depending on application, refer to device data sheet. If any vias are implemented, refer to their locations shown on this view. It is recommended that vias under paste be filled, plugged or tented.

# EXAMPLE STENCIL DESIGN

DDA0008B

PowerPAD™ SOIC - 1.7 mm max height

PLASTIC SMALL OUTLINE

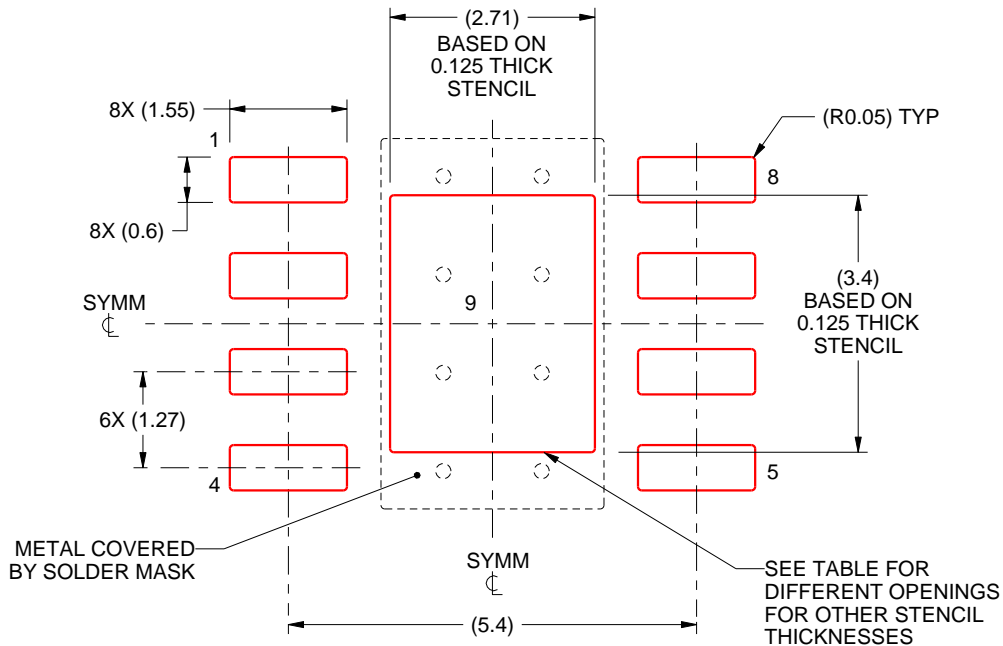

SOLDER PASTE EXAMPLE  
 EXPOSED PAD  
 100% PRINTED SOLDER COVERAGE BY AREA  
 SCALE:10X

STENCIL THICKNESS	SOLDER STENCIL OPENING
0.1	3.03 X 3.80
0.125	2.71 X 3.40 (SHOWN)
0.150	2.47 X 3.10
0.175	2.29 X 2.87

4214849/A 08/2016



NOTES: (continued)

11. Laser cutting apertures with trapezoidal walls and rounded corners may offer better paste release. IPC-7525 may have alternate design recommendations.
12. Board assembly site may have different recommendations for stencil design.

D (R-PDSO-G14)

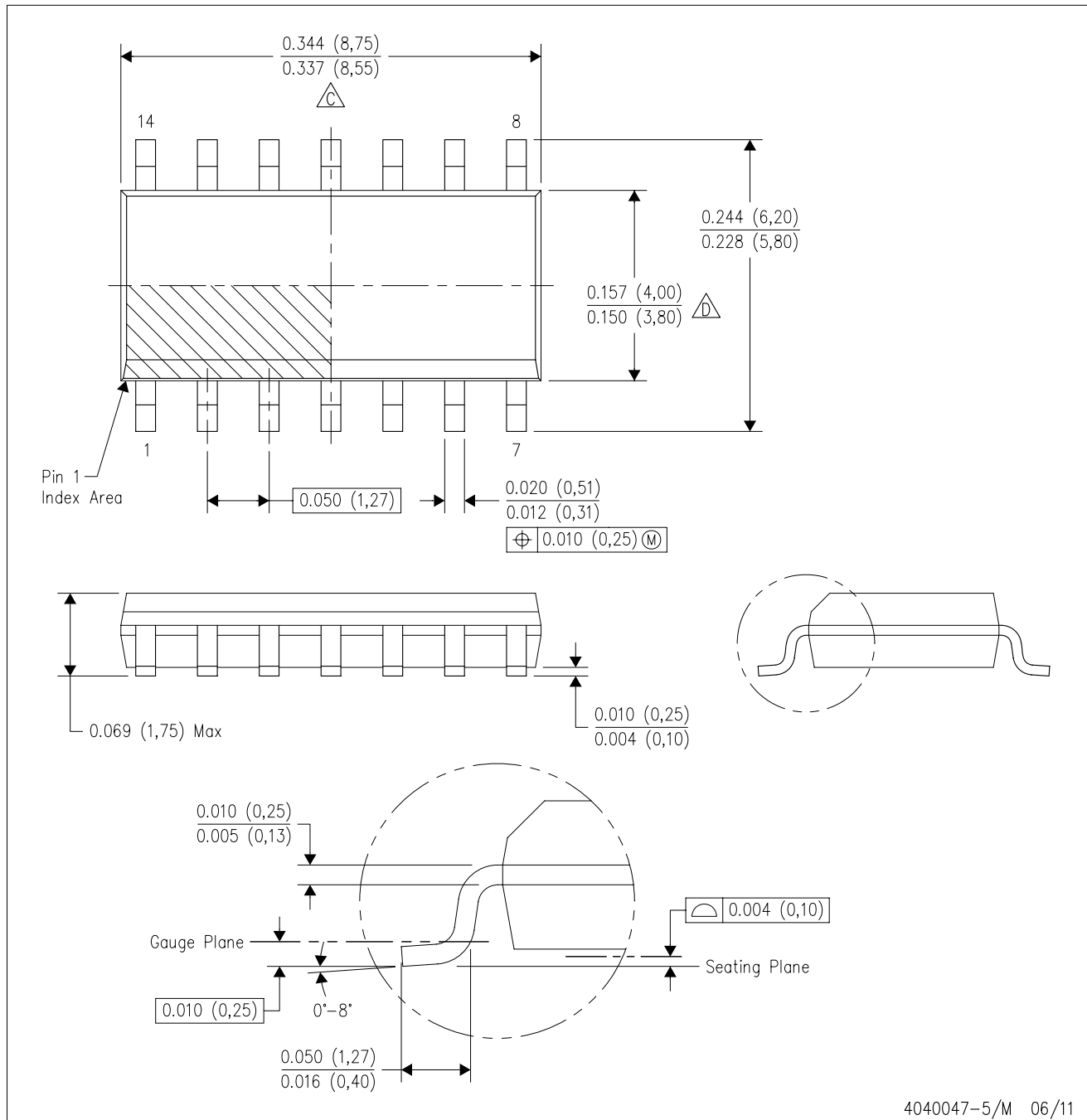
PLASTIC SMALL OUTLINE



- NOTES:
- A. All linear dimensions are in inches (millimeters).
  - B. This drawing is subject to change without notice.
  -  Body length does not include mold flash, protrusions, or gate burrs. Mold flash, protrusions, or gate burrs shall not exceed 0.006 (0,15) each side.
  -  Body width does not include interlead flash. Interlead flash shall not exceed 0.017 (0,43) each side.
  - E. Reference JEDEC MS-012 variation AB.

D (R-PDSO-G14)

PLASTIC SMALL OUTLINE



4211283-3/E 08/12

- NOTES:
- All linear dimensions are in millimeters.
  - This drawing is subject to change without notice.
  - Publication IPC-7351 is recommended for alternate designs.
  - Laser cutting apertures with trapezoidal walls and also rounding corners will offer better paste release. Customers should contact their board assembly site for stencil design recommendations. Refer to IPC-7525 for other stencil recommendations.
  - Customers should contact their board fabrication site for solder mask tolerances between and around signal pads.



D0008A

# PACKAGE OUTLINE

SOIC - 1.75 mm max height

SMALL OUTLINE INTEGRATED CIRCUIT



NOTES:

1. Linear dimensions are in inches [millimeters]. Dimensions in parenthesis are for reference only. Controlling dimensions are in inches. Dimensioning and tolerancing per ASME Y14.5M.
2. This drawing is subject to change without notice.
3. This dimension does not include mold flash, protrusions, or gate burrs. Mold flash, protrusions, or gate burrs shall not exceed  $.006$  [0.15] per side.
4. This dimension does not include interlead flash.
5. Reference JEDEC registration MS-012, variation AA.

# EXAMPLE BOARD LAYOUT

D0008A

SOIC - 1.75 mm max height

SMALL OUTLINE INTEGRATED CIRCUIT



LAND PATTERN EXAMPLE  
 EXPOSED METAL SHOWN  
 SCALE:8X



SOLDER MASK DETAILS

4214825/C 02/2019

NOTES: (continued)

- 6. Publication IPC-7351 may have alternate designs.
- 7. Solder mask tolerances between and around signal pads can vary based on board fabrication site.

# EXAMPLE STENCIL DESIGN

D0008A

SOIC - 1.75 mm max height

SMALL OUTLINE INTEGRATED CIRCUIT



SOLDER PASTE EXAMPLE  
BASED ON .005 INCH [0.125 MM] THICK STENCIL  
SCALE:8X

4214825/C 02/2019

NOTES: (continued)

8. Laser cutting apertures with trapezoidal walls and rounded corners may offer better paste release. IPC-7525 may have alternate design recommendations.
9. Board assembly site may have different recommendations for stencil design.

## IMPORTANT NOTICE AND DISCLAIMER

TI PROVIDES TECHNICAL AND RELIABILITY DATA (INCLUDING DATASHEETS), DESIGN RESOURCES (INCLUDING REFERENCE DESIGNS), APPLICATION OR OTHER DESIGN ADVICE, WEB TOOLS, SAFETY INFORMATION, AND OTHER RESOURCES "AS IS" AND WITH ALL FAULTS, AND DISCLAIMS ALL WARRANTIES, EXPRESS AND IMPLIED, INCLUDING WITHOUT LIMITATION ANY IMPLIED WARRANTIES OF MERCHANTABILITY, FITNESS FOR A PARTICULAR PURPOSE OR NON-INFRINGEMENT OF THIRD PARTY INTELLECTUAL PROPERTY RIGHTS.

These resources are intended for skilled developers designing with TI products. You are solely responsible for (1) selecting the appropriate TI products for your application, (2) designing, validating and testing your application, and (3) ensuring your application meets applicable standards, and any other safety, security, or other requirements. These resources are subject to change without notice. TI grants you permission to use these resources only for development of an application that uses the TI products described in the resource. Other reproduction and display of these resources is prohibited. No license is granted to any other TI intellectual property right or to any third party intellectual property right. TI disclaims responsibility for, and you will fully indemnify TI and its representatives against, any claims, damages, costs, losses, and liabilities arising out of your use of these resources.

TI's products are provided subject to TI's Terms of Sale ([www.ti.com/legal/termsofsale.html](http://www.ti.com/legal/termsofsale.html)) or other applicable terms available either on [ti.com](http://ti.com) or provided in conjunction with such TI products. TI's provision of these resources does not expand or otherwise alter TI's applicable warranties or warranty disclaimers for TI products.

Mailing Address: Texas Instruments, Post Office Box 655303, Dallas, Texas 75265  
Copyright © 2019, Texas Instruments Incorporated

## Looking for pricing, stock, or lifecycle information?

Click below to explore more details on WIN SOURCE:

 [View THS3122IDRG4 on WIN SOURCE](#)

 [Texas Instruments](#) Information

## Optimize Your Supply Chain with WIN SOURCE Solutions

-  Global Sourcing Solution
-  Obsolete Management
-  Cost Control Management
-  Shortage Management
-  Alternative Solution
-  Excess Inventory Management