



**THE DATASHEET OF
P3PS550AHG-08-CR**



P3PS550AH

High Drive General Purpose Peak EMI Reduction IC

Product Description

The P3PS550AH is a versatile 2.3 V to 3.6 V, Timing-Safe™, high drive spread spectrum frequency modulator designed specifically for a wide range of clock frequencies. The P3PS550AH reduces electromagnetic interference (EMI) at the clock source, allowing system wide reduction of EMI of all clock dependent signals. The P3PS550AH allows significant system cost savings by reducing the number of circuit board layers ferrite beads, shielding that are traditionally required to pass EMI regulations.

Features

- High Drive, LVCMOS Peak EMI reduction IC
- Input Clock Frequency: 18 MHz – 36 MHz
- Output Clock Frequency: 18 MHz – 36 MHz
- Eight different selectable Spread options
- Power Down option for power save
- Supply Voltage: 2.3 V – 3.6 V
- 8-pin WDFN, 2 mm x 2 mm (TDFN) Package
- These Devices are Pb-Free, Halogen Free/BFR Free and are RoHS Compliant

Applications

- The P3PS550AH is targeted towards consumer electronic applications.



ON Semiconductor®

<http://onsemi.com>

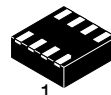

WDFN8
CASE 511AQ

MARKING DIAGRAMS

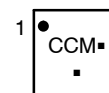

CC = Specific Device Code
M = Date Code
▪ = Pb-Free Device

PIN CONFIGURATION

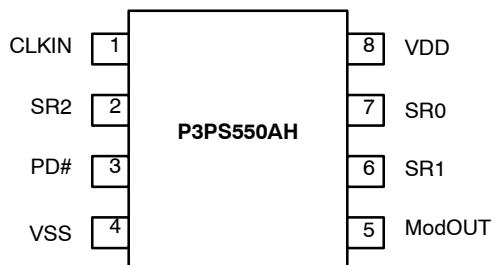

ORDERING INFORMATION

See detailed ordering and shipping information in the package dimensions section on page 5 of this data sheet.

P3PS550AH

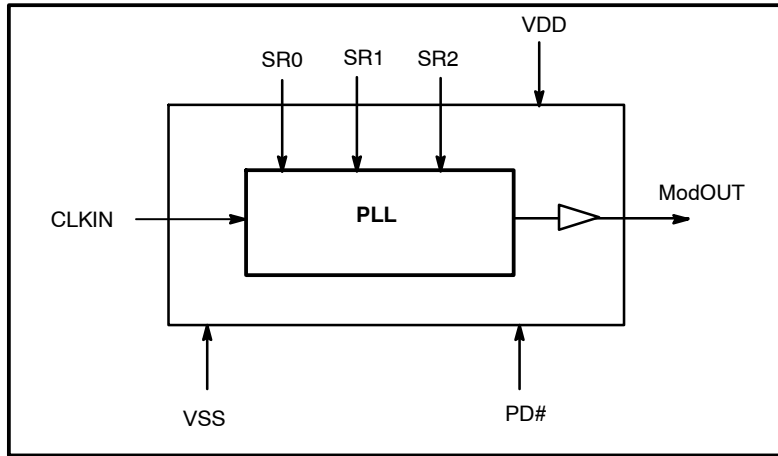

Figure 1. Block Diagram

P3PS550AH modulates the output of a single PLL in order to “spread” the bandwidth of a synthesized clock, and more importantly, decreases the peak amplitudes of its harmonics. This results in significantly lower system EMI compared to the typical narrow band signal produced by oscillators and most frequency generators. Lowering EMI by increasing a signal’s bandwidth is called ‘spread spectrum clock generation’.

P3PS550AH accepts an input from an external reference clock and locks to a 1x modulated clock output. SR0, SR1 and SR2 pins enable selecting one of the eight different frequency deviations (Refer *Frequency Deviation Selection table*). P3PS550AH also features power down option for power save. P3PS550AH operates over a supply voltage range of 2.3 V to 3.6 V. P3PS550AH is available in an 8 Pin WDFN, (2 mm x 2 mm) Package.

Table 1. PIN DESCRIPTION

Pin#	Pin Name	Type	Description
1	CLKIN	I	External reference clock input.
2	SR2	I	Digital logic input used to select Spreading Range. There is NO default state. Refer <i>Frequency Deviation Selection Table</i> .
3	PD#	I	Power-down control pin. Powers down the entire chip. There is NO default state. Pull low to enable power-down mode. Connect to VDD to disable Power Down. Output Clock will be LOW when power down is enabled
4	VSS	P	Ground connection.
5	ModOUT	O	Spread Spectrum Clock Output.
6	SR1	I	Digital logic input used to select Spreading Range. This pin has an internal pull-up resistor. Refer <i>Modulation Selection Table</i> .
7	SR0	I	Digital logic input used to select Spreading Range. There is NO default state. Refer <i>Frequency Deviation Selection Table</i> .
8	VDD	P	Power supply for the entire chip

P3PS550AH

Table 2. FREQUENCY DEVIATION SELECTION TABLE

SR2	SR1	SR0	Spreading Range (± %) (@ 24 MHz)
0	0	0	1
0	0	1	2.5
0	1	0	1.25
0	1	1	1.5
1	0	0	0.4
1	0	1	0.75
1	1	0	1.75
1	1	1	2

Table 3. OPERATING CONDITIONS

Symbol	Parameter	Min	Max	Unit
V _{DD}	Supply Voltage with respect to V _{SS}	2.3	3.6	V
T _A	Operating temperature	-20	+85	°C
C _L	Load Capacitance		15	pF
C _{IN}	Input Capacitance		7	pF

Table 4. ABSOLUTE MAXIMUM RATING

Symbol	Parameter	Rating	Unit
V _{DD} , V _{IN}	Voltage on any input pin with respect to V _{SS}	-0.5 to +4.6	V
T _{STG}	Storage temperature	-65 to +125	°C
T _s	Max. Soldering Temperature (10 sec)	260	°C
T _J	Junction Temperature	150	°C
T _{DV}	Static Discharge Voltage (As per JEDEC STD22-A114-B)	2	kV

Stresses exceeding Maximum Ratings may damage the device. Maximum Ratings are stress ratings only. Functional operation above the Recommended Operating Conditions is not implied. Extended exposure to stresses above the Recommended Operating Conditions may affect device reliability.

Table 5. DC ELECTRICAL CHARACTERISTICS

Symbol	Parameter	Min	Typ	Max	Unit
V _{DD}	Supply Voltage with respect to V _{SS}	2.3	2.8	3.6	V
V _{IH}	Input high voltage	0.65 * V _{DD}			V
V _{IL}	Input low voltage			0.3 * V _{DD}	V
I _{IH}	Input high current (SR1 control pin)			50	μA
I _{IL}	Input low current (SR1 control pin)			50	μA
V _{OH}	Output high voltage (I _{OH} = - 16 mA)	0.75 * V _{DD}			V
V _{OL}	Output low voltage (I _{OL} = 16 mA)			0.2 * V _{DD}	V
I _{CC}	Static supply current (PD# pulled to V _{SS})			1	μA
I _{DD}	Dynamic supply current (Unloaded Output @ 24 MHz)		6	9	mA
Z _{OUT}	Output impedance		20		Ω

P3PS550AH

Table 6. AC ELECTRICAL CHARACTERISTICS

Symbol	Parameter	Min	Typ	Max	Unit
CLKIN	Input Clock frequency	18	24	36	MHz
ModOUT	Output Clock frequency	18	24	36	MHz
t_{LH} (Note 1)	Output rise time (Measured between 20% to 80%)	Unloaded Output	0.4	0.8	ns
		$C_L = 15\text{ pF}$	1.4	2.2	
t_{HL} (Note 1)	Output fall time (Measured between 80% to 20%)	Unloaded Output	0.3	0.6	ns
		$C_L = 15\text{ pF}$	1.1	1.9	
t_{JC} (Note 1)	Jitter (cycle to cycle) Unloaded Output		± 175	± 250	ps
t_D (Note 1)	Output duty cycle	45	50	55	%
t_{ON} (Note 1)	PLL lock Time (Stable power supply, valid clock presented on CLKIN pin, PD# toggled from Low to High)			3	ms
fd_{var}	Frequency Deviation Variation across PVT		± 2.5	± 5	%

1. Parameter is guaranteed by design and characterization. Not 100% tested in production

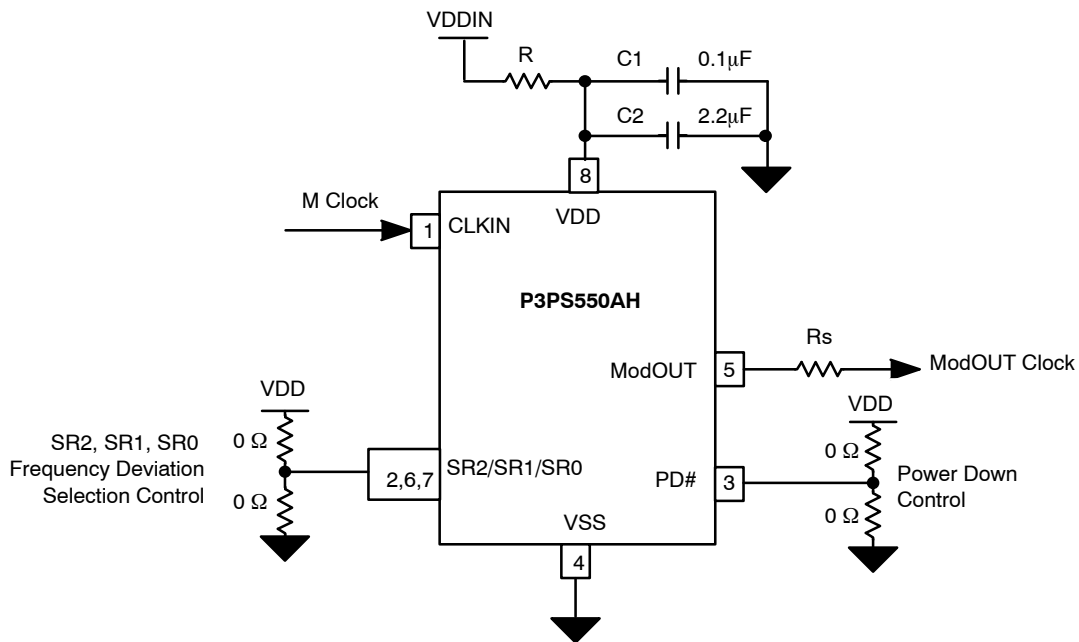

NOTE: Refer Pin Description table for Functionality details.

Figure 2. Typical Application Schematic

PCB Layout Recommendation

For optimum device performance, following guidelines are recommended.

- Dedicated VDD and GND planes.
- The device must be isolated from system power supply noise. A 0.1µF and a 2.2 µF decoupling capacitor should be mounted on the component side of the board as close to the VDD pin as possible. No vias should be used between the decoupling capacitor and VDD pin. The PCB trace to VDD pin and the ground via should be kept as short as possible. All the VDD pins should have decoupling capacitors.
- In an optimum layout all components are on the same side of the board, minimizing vias through other signal layers.

A typical layout is shown in the figure

P3PS550AH

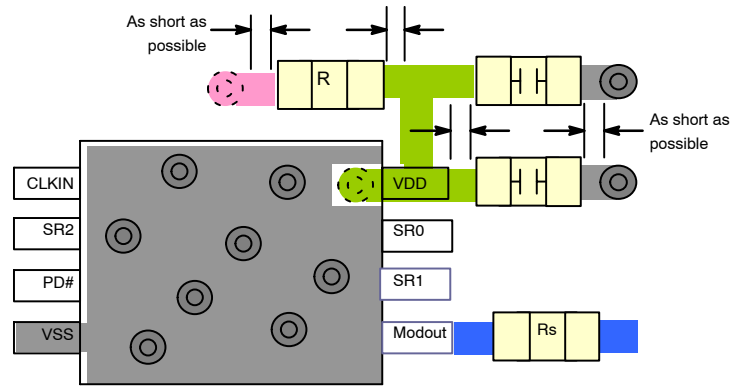

Figure 3.

ORDERING INFORMATION

Part Number	Top Marking	Temperature	Package Type	Shipping [†]
P3PS550AHG-08CR	CC	-20°C to +85°C	8-pin (2 mm x 2 mm) WDFN	Tape & Reel

P3PS550AH

PACKAGE DIMENSIONS

WDFN8 2x2, 0.5P
CASE 511AQ-01
ISSUE A

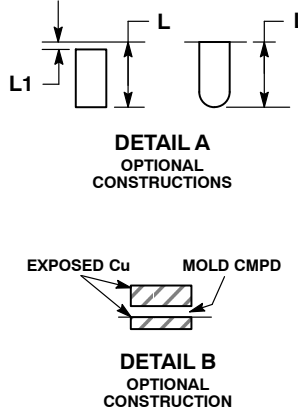
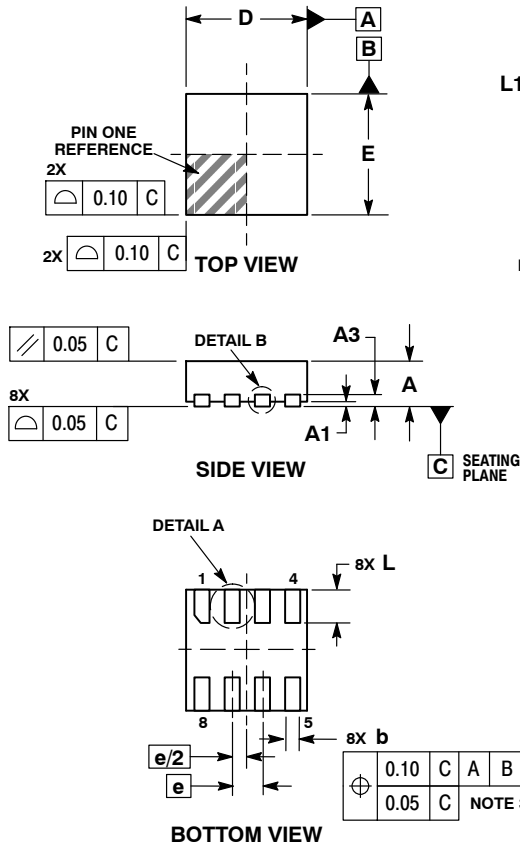

- NOTES:
1. DIMENSIONING AND TOLERANCING PER ASME Y14.5M, 1994.
 2. CONTROLLING DIMENSION: MILLIMETERS.
 3. DIMENSION b APPLIES TO PLATED TERMINAL AND IS MEASURED BETWEEN 0.15 AND 0.30mm FROM TERMINAL.

DIM	MILLIMETERS	
	MIN	MAX
A	0.70	0.80
A1	0.00	0.05
A3	0.20	REF
b	0.20	0.30
D	2.00	BSC
E	2.00	BSC
e	0.50	BSC
L	0.50	0.60
L1	---	0.15

RECOMMENDED SOLDERING FOOTPRINT*

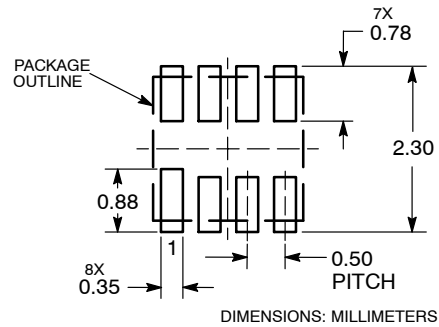

*For additional information on our Pb-Free strategy and soldering details, please download the ON Semiconductor Soldering and Mounting Techniques Reference Manual, SOLDERRM/D.

Timing-Safe is a trademark of Semiconductor Components Industries, LLC (SCILLC).

ON Semiconductor and are registered trademarks of Semiconductor Components Industries, LLC (SCILLC). SCILLC reserves the right to make changes without further notice to any products herein. SCILLC makes no warranty, representation or guarantee regarding the suitability of its products for any particular purpose, nor does SCILLC assume any liability arising out of the application or use of any product or circuit, and specifically disclaims any and all liability, including without limitation special, consequential or incidental damages. "Typical" parameters which may be provided in SCILLC data sheets and/or specifications can and do vary in different applications and actual performance may vary over time. All operating parameters, including "Typicals" must be validated for each customer application by customer's technical experts. SCILLC does not convey any license under its patent rights nor the rights of others. SCILLC products are not designed, intended, or authorized for use as components in systems intended for surgical implant into the body, or other applications intended to support or sustain life, or for any other application in which the failure of the SCILLC product could create a situation where personal injury or death may occur. Should Buyer purchase or use SCILLC products for any such unintended or unauthorized application, Buyer shall indemnify and hold SCILLC and its officers, employees, subsidiaries, affiliates, and distributors harmless against all claims, costs, damages, and expenses, and reasonable attorney fees arising out of, directly or indirectly, any claim of personal injury or death associated with such unintended or unauthorized use, even if such claim alleges that SCILLC was negligent regarding the design or manufacture of the part. SCILLC is an Equal Opportunity/Affirmative Action Employer. This literature is subject to all applicable copyright laws and is not for resale in any manner.

PUBLICATION ORDERING INFORMATION

LITERATURE FULFILLMENT:
Literature Distribution Center for ON Semiconductor
P.O. Box 5163, Denver, Colorado 80217 USA
Phone: 303-675-2175 or 800-344-3860 Toll Free USA/Canada
Fax: 303-675-2176 or 800-344-3867 Toll Free USA/Canada
Email: orderlit@onsemi.com

N. American Technical Support: 800-282-9855 Toll Free USA/Canada
Europe, Middle East and Africa Technical Support:
Phone: 421 33 790 2910
Japan Customer Focus Center
Phone: 81-3-5773-3850

ON Semiconductor Website: www.onsemi.com
Order Literature: <http://www.onsemi.com/orderlit>
For additional information, please contact your local Sales Representative

Looking for pricing, stock, or lifecycle information?

Click below to explore more details on WIN SOURCE:

- ⊖ [View P3PS550AHG-08-CR on WIN SOURCE](#)
- ⊖ [ON Semiconductor Information](#)

Optimize Your Supply Chain with WIN SOURCE Solutions

- ✓ Global Sourcing Solution
- ✓ Obsolete Management
- ✓ Cost Control Management
- ✓ Shortage Management
- ✓ Alternative Solution
- ✓ Excess Inventory Management