



**THE DATASHEET OF
HCF4054M013TR**





HCF4054B

4 SEGMENT LIQUID CRYSTAL DISPLAY DRIVER WITH STROBED LATCH FUNCTION

- QUIESCENT CURRENT SPECIF. UP TO 20V
- OPERATION OF LIQUID CRYSTALS WITH CMOS CIRCUITS PROVIDES ULTRA LOW POWER DISPLAYS
- EQUIVALENT AC OUTPUT DRIVE FOR LIQUID CRYSTAL DISPLAYS - NO EXTERNAL CAPACITOR REQUIRED
- VOLTAGE DOUBLING ACROSS DISPLAY [($V_{DD} - V_{EE}$) = 18V] RESULTS IN EFFECTIVE 36V (p-p) DRIVE ACROSS SELECTED DISPLAY SEGMENTS
- LOW OR HIGH OUTPUT LEVEL DC DRIVE FOR OTHER TYPES OF DISPLAYS
- ONE CHIP LOGIC LEVEL CONVERSION FOR DIFFERENT INPUT AND OUTPUT LEVEL SWINGS
- FULL DECODING OF ALL INPUT COMBINATIONS : "0 - 9, L, H, P, A" AND BLANK POSITIONS
- INPUT LEAKAGE CURRENT
 $I_l = 100\text{nA}$ (MAX) AT $V_{DD} = 18\text{V}$ $T_A = 25^\circ\text{C}$
- 100% TESTED FOR QUIESCENT CURRENT
- MEETS ALL REQUIREMENTS OF JEDEC JESD13B "STANDARD SPECIFICATIONS FOR DESCRIPTION OF B SERIES CMOS DEVICES"

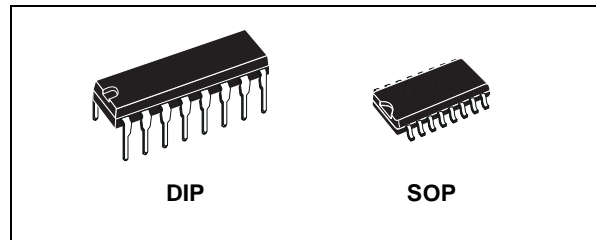

ORDER CODES

PACKAGE	TUBE	T & R
DIP	HCF4054BEY	
SOP	HCF4054BM1	HCF4054M013TR

HCF4054B provides level shifting similar to HCF4055B and HCF4056B, independently strobed latches, and common DF control on 4 signal lines. This device is intended to provide drive signal compatibility with HCF4055B and HCF4056B 7-segment decoder types for the decimal point, colon, polarity, and similar display lines. A level-shifted high amplitude DF output can be obtained from any HCF4054B output line by connecting the corresponding input and strobe lines to a low and high levels. HCF4054B may also be utilized for logic level "up conversion" or "down conversion" respectively. For example, input signal swings (V_{DD} to V_{SS}) from +5V to 0V

DESCRIPTION

HCF4054B is a monolithic integrated circuit fabricated in Metal Oxide Semiconductor technology available in DIP and SOP packages.

PIN CONNECTION

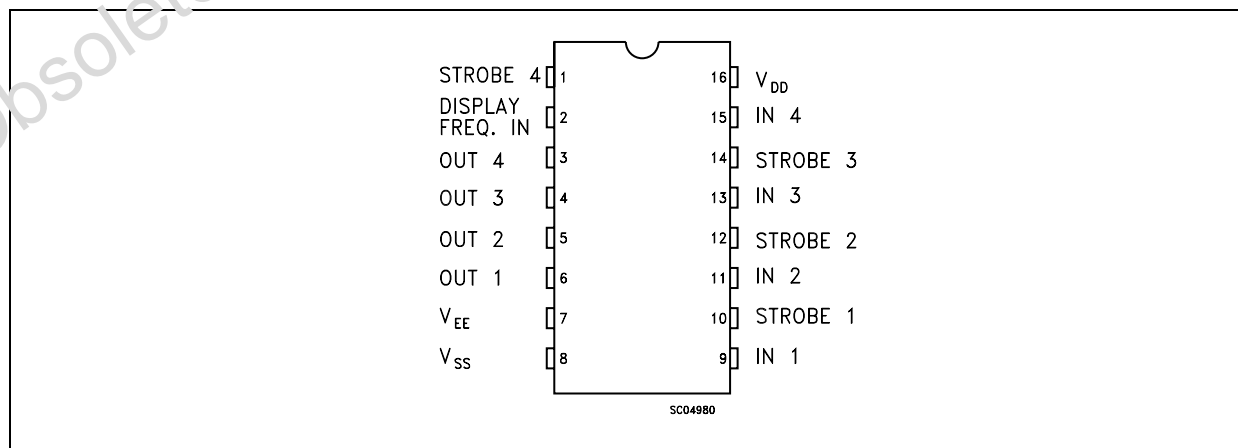

HCF4054B

can be converted to output signal swings (V_{DD} to V_{EE}) of +5V to -5V. The level shifted function permits the use of different input and output signal swings. The input swings from a low level of V_{SS} to a high level of V_{DD} , while the outputs swings from a low level of V_{EE} to the same high level of V_{DD} . Thus, the input and output swings can be

INPUT EQUIVALENT CIRCUIT

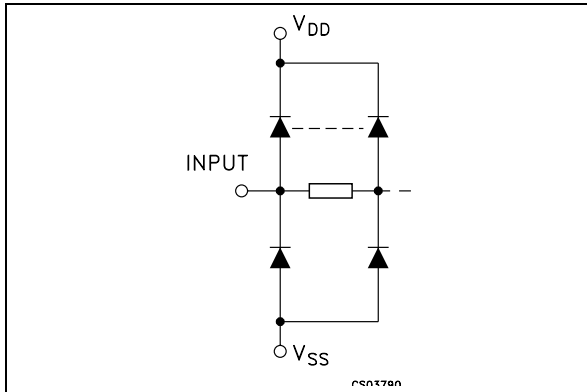

selected independently of each other over a 3 to 18V range. V_{SS} may be connected to V_{EE} when no level-shift function is required. Data is transferred from input to output by placing a high voltage level at the strobe input. A low voltage level at the strobe input latches the data input and the corresponding output segments remain selected (or non selected) while the strobe is low.

PIN DESCRIPTION

PIN No	SYMBOL	NAME AND FUNCTION
6, 5, 4, 3	OUT1 to OUT4	Outputs
9, 11, 13, 15	IN1 to IN4	Inputs
10, 12, 14, 1	STROBE1 STROBE4	Strobe Input
2	DISPLAY FREQ. IN	Display Frequency Input
7	V_{EE}	Negative Supply Voltage
8	V_{SS}	Negative Supply Voltage
16	V_{DD}	Positive Supply Voltage

TRUTH TABLE

DF	IN	STROBE	OUT
L	L	H	L
H	L	H	H
L	H	H	H
H	H	H	L
X	X	L	*

X = Don't Care.

(*) Depends upon the input mode previously applied when ST=1.

LOGIC DIAGRAM

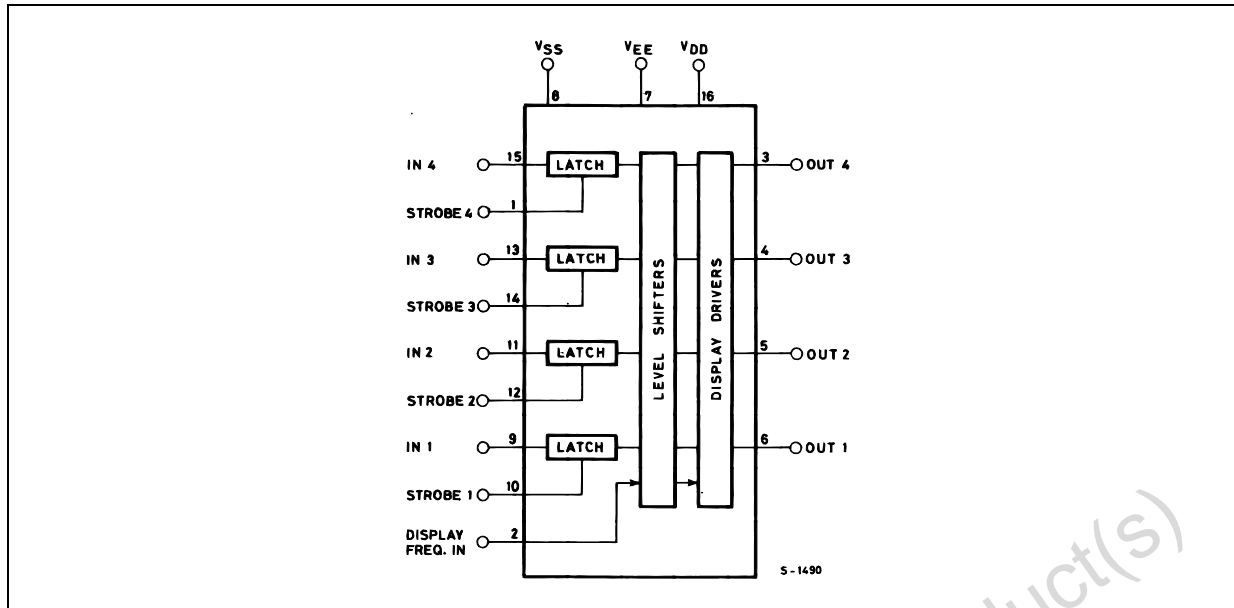

ABSOLUTE MAXIMUM RATINGS

Symbol	Parameter	Value	Unit
V_{DD}	Supply Voltage	-0.5 to +22	V
V_I	DC Input Voltage	-0.5 to $V_{DD} + 0.5$	V
I_I	DC Input Current	± 10	mA
P_D	Power Dissipation per Package	200	mW
	Power Dissipation per Output Transistor	100	mW
T_{op}	Operating Temperature	-55 to +125	$^{\circ}\text{C}$
T_{stg}	Storage Temperature	-65 to +150	$^{\circ}\text{C}$

Absolute Maximum Ratings are those values beyond which damage to the device may occur. Functional operation under these conditions is not implied.

All voltage values are referred to V_{SS} pin voltage.

RECOMMENDED OPERATING CONDITIONS

Symbol	Parameter	Value	Unit
V_{DD}	Supply Voltage	3 to 20	V
V_I	Input Voltage	0 to V_{DD}	V
T_{op}	Operating Temperature	-55 to 125	$^{\circ}\text{C}$

DC SPECIFICATIONS

Symbol	Parameter	Test Condition					Value						Unit	
		V _{EE} (V)	V _I (V)	V _O (V)	V _{SS} (V)	V _{DD} (V)	T _A = 25°C			-40 to 85°C		-55 to 125°C		
							Min.	Typ.	Max.	Min.	Max.	Min.		Max.
I _L	Quiescent Current	-5	0/5		0	5		0.04	5		150		150	μA
		0	0/10		0	10		0.04	10		300		300	
		0	0/15		0	15		0.04	20		600		600	
		0	0/20		0	20		0.08	100		3000		3000	
V _{OH}	High Level Output Voltage	0	0/5		0	5	4.95			4.95		4.95	V	
		0	0/10		0	10	9.95			9.95		9.95		
		0	0/15		0	15	14.95			14.95		14.95		
V _{OL}	Low Level Output Voltage	0	5/0		0	5		0.05			0.05		0.05	V
		0	10/0		0	10		0.05			0.05		0.05	
		0	15/0		0	15		0.05			0.05		0.05	
V _{IH}	High Level Input Voltage	-5		0.5/4.5	0	5	3.5			3.5		3.5	V	
		0		1/9	0	10	7			7		7		
		0		1.5/18.5	0	15	11			11		11		
V _{IL}	Low Level Input Voltage	5		0.5/4.5	0	5			1.5		1.5		1.5	V
		0		9/1	0	10			3		3		3	
		0		1.5/18.5	0	15			4		4		4	
I _{OH}	Output Drive Current	-5	0/5	4.5	0	5	-0.38	-0.9		-0.28		-0.28		mA
		0	0/10	9.5	0	10	-0.38	-0.9		-0.28		-0.28		
		0	0/15	13.5	0	15	-1.27	-3		-0.95		-0.95		
I _{OL}	Output Sink Current	-5	0/5	0.4	0	5	1.1	2.6		0.82		0.82		mA
		0	0/10	0.5	0	10	1.1	2.6		0.82		0.82		
		0	0/15	1.5	0	15	2.9	6.8		2.17		2.17		
I _I	Input Leakage Current (any input)	0	0/18		0	18		±10 ⁻⁵	±0.1		±1		±1	μA
C _I	Input Capacitance (any input)							5	7.5					pF

The Noise Margin for both "1" and "0" level is: 1V min. with V_{DD}=5V, 2V min. with V_{DD}=10V, 2.5V min. with V_{DD}=15V

DYNAMIC ELECTRICAL CHARACTERISTICS (T_{amb} = 25°C, C_L = 50pF, R_L = 200KΩ, t_r = t_f = 20 ns)

Symbol	Parameter	Test Condition				Value (*)			Unit
		V _{EE} (V)	V _{SS} (V)	V _{DD} (V)		Min.	Typ.	Max.	
t _{PHL} t _{PLH}	Propagation Delay Time (any Input to any Output)	-5	0	5			400	800	ns
		0	0	10			340	680	
		0	0	15			250	500	
t _{THL} t _{TLH}	Transition Time (any Output)	-5	0	5			100	200	ns
		0	0	10			100	200	
		0	0	15			75	150	
t _{setup}	Data Setup Time	-5	0	5			220	110	ns
		0	0	10			100	50	
		0	0	15			70	35	
t _w	Strobe Pulse Width	-5	0	5			220	110	ns
		0	0	10			100	50	
		0	0	15			70	35	

(*) Typical temperature coefficient for all V_{DD} value is 0.3 %/°C.

TYPICAL APPLICATIONS

Display Driver Circuit.

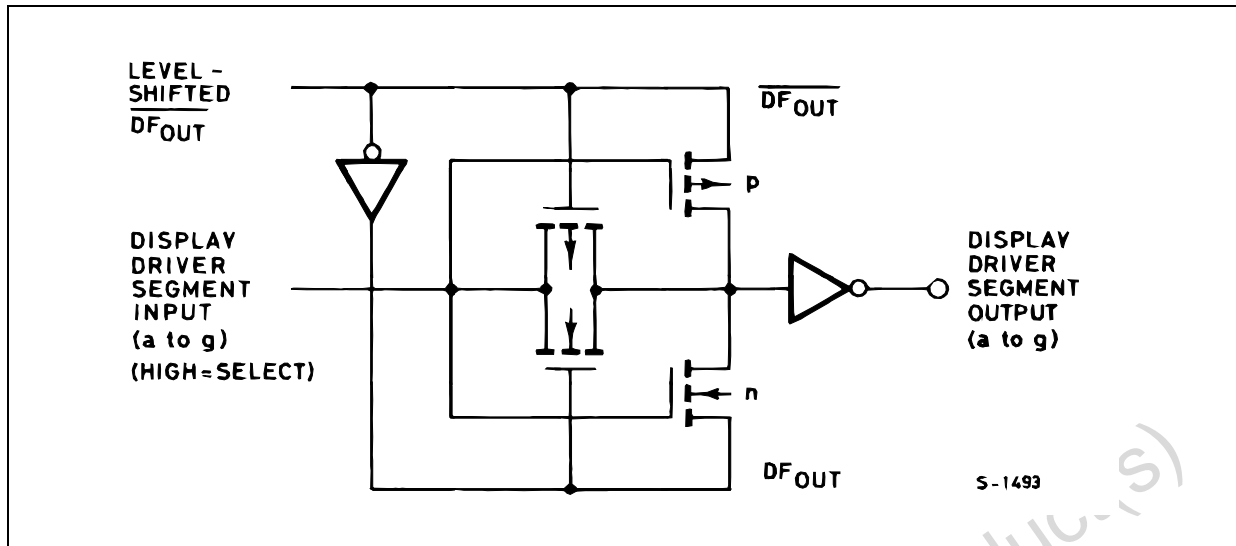

Display Driver Waveform..

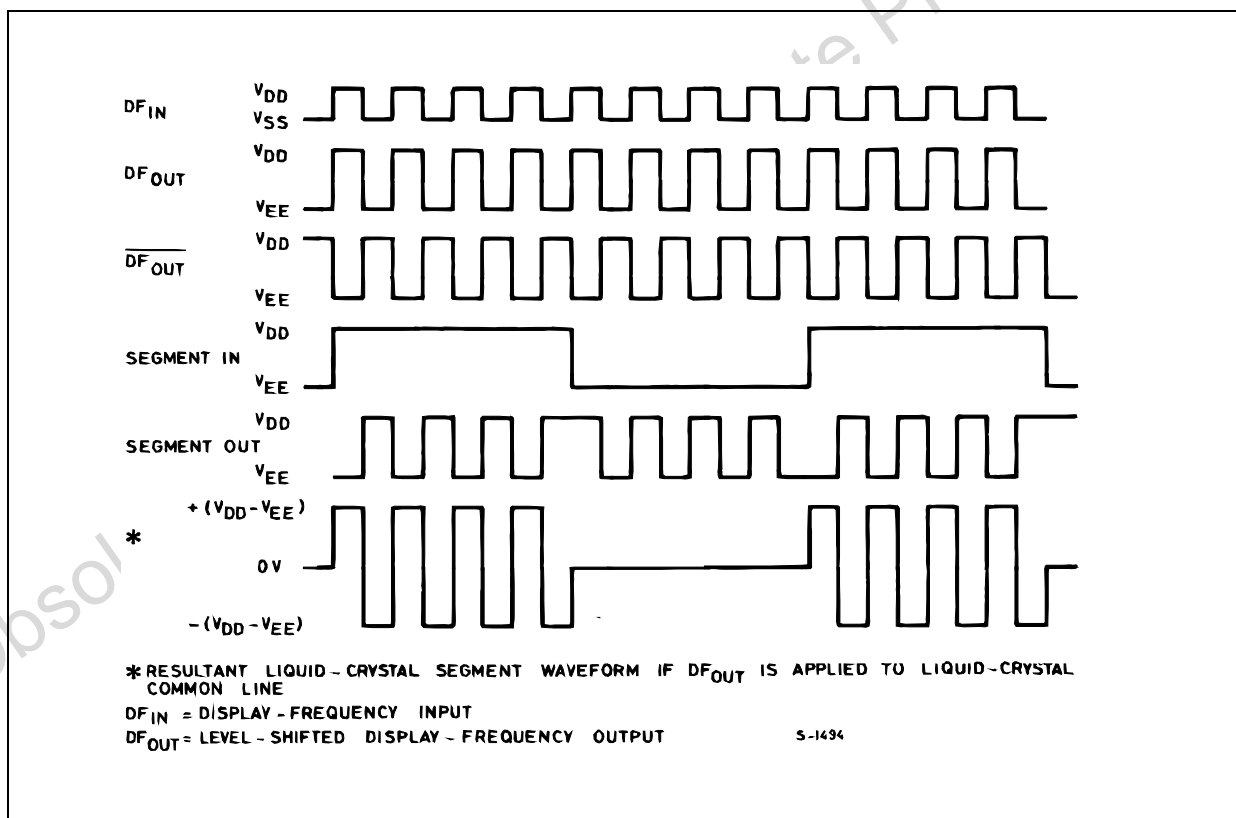

HCF4054B

Digital (0 to +5V) to Bidirectional Analog Control (+5V to -5V) Level Shifter.

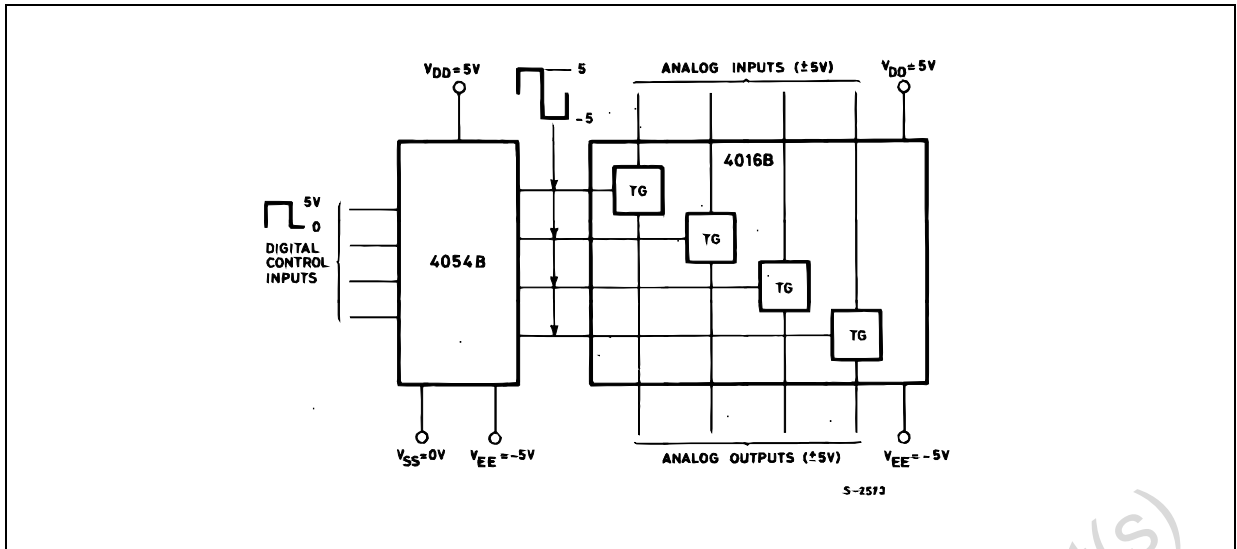

Typical 3½ Digit Crystal Display : ($V_{DD} = +5V$, $V_{SS} = 0V$, $V_{EE} = -10V$, $DF_N = 30Hz$ Square)

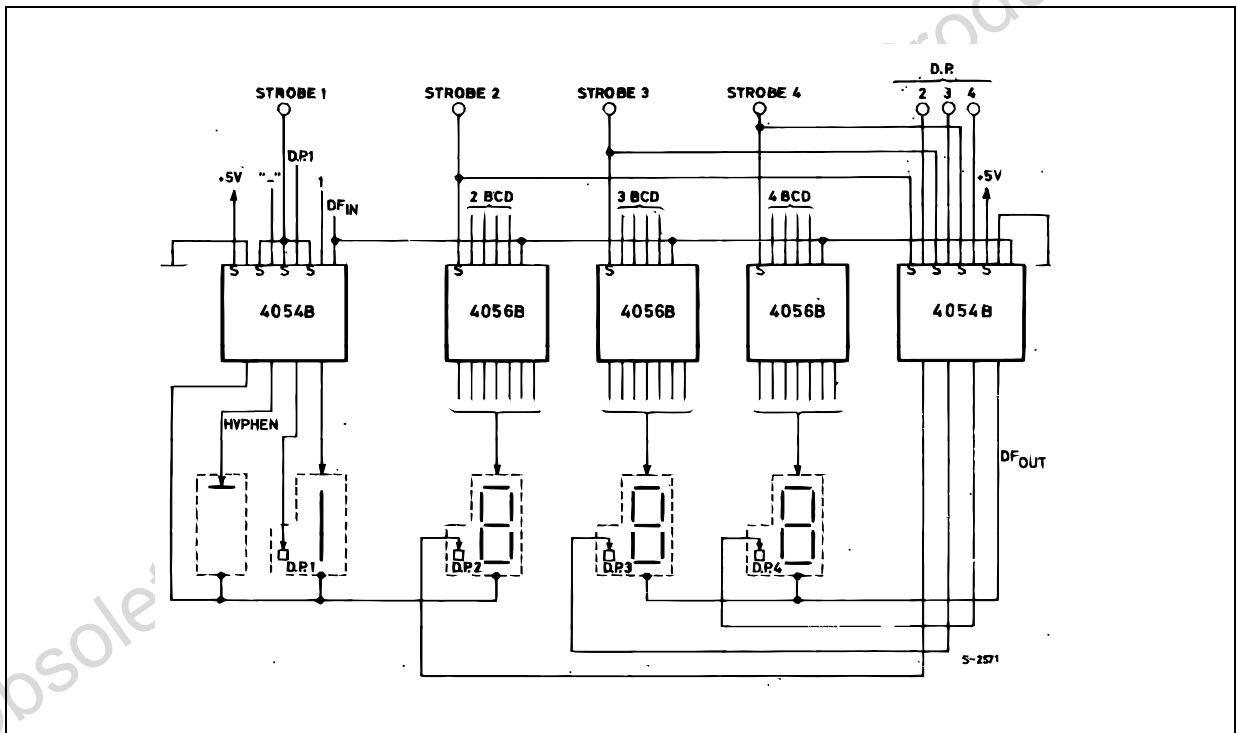

TEST CIRCUIT

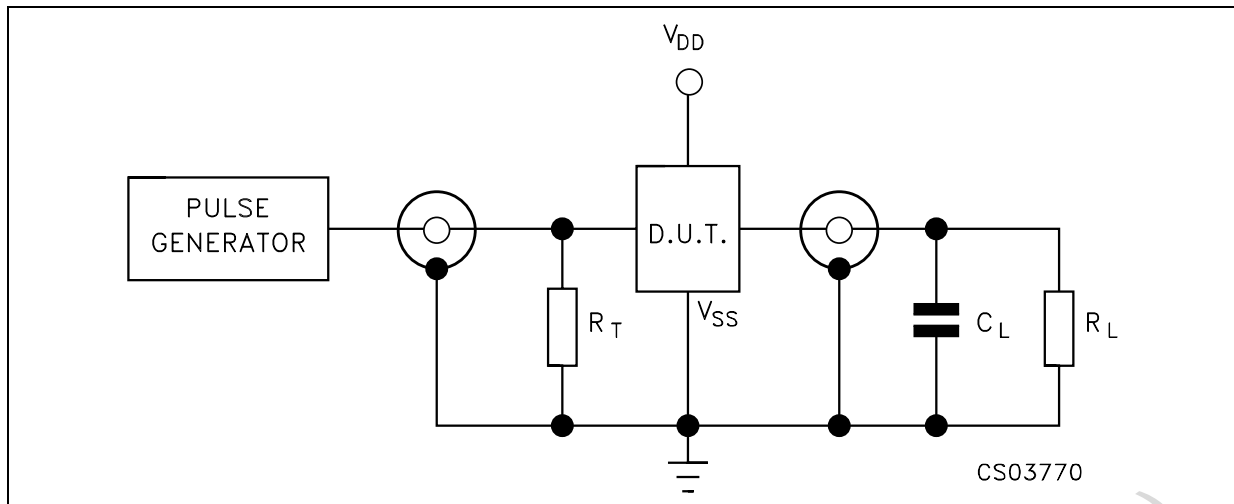

$C_L = 50\text{pF}$ or equivalent (includes jig and probe capacitance)
 $R_L = 200\text{k}\Omega$
 $R_T = Z_{\text{OUT}}$ of pulse generator (typically 50Ω)

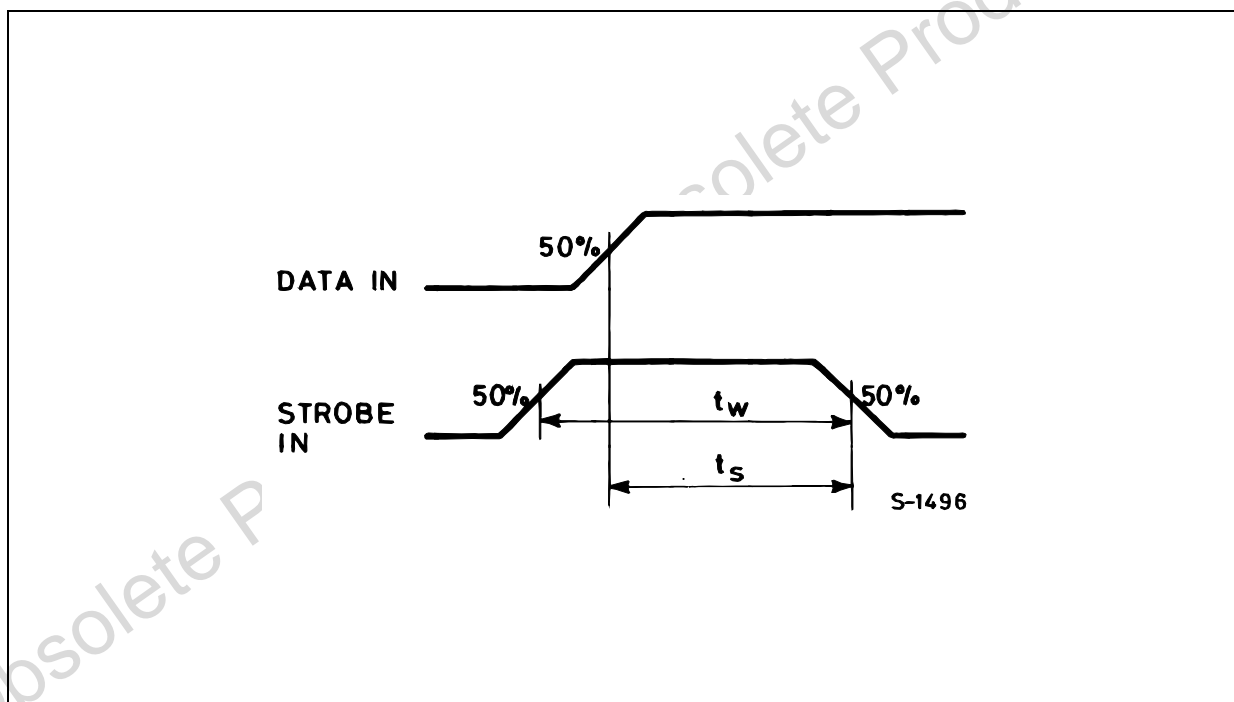
WAVEFORM : DATA SETUP TIME AND STROBE PULSE DURATION ($f=1\text{MHz}$; 50% duty cycle)

Plastic DIP-16 (0.25) MECHANICAL DATA

DIM.	mm.			inch		
	MIN.	TYP	MAX.	MIN.	TYP.	MAX.
a1	0.51			0.020		
B	0.77		1.65	0.030		0.065
b		0.5			0.020	
b1		0.25			0.010	
D			20			0.787
E		8.5			0.335	
e		2.54			0.100	
e3		17.78			0.700	
F			7.1			0.280
I			5.1			0.201
L		3.3			0.130	
Z			1.27			0.050

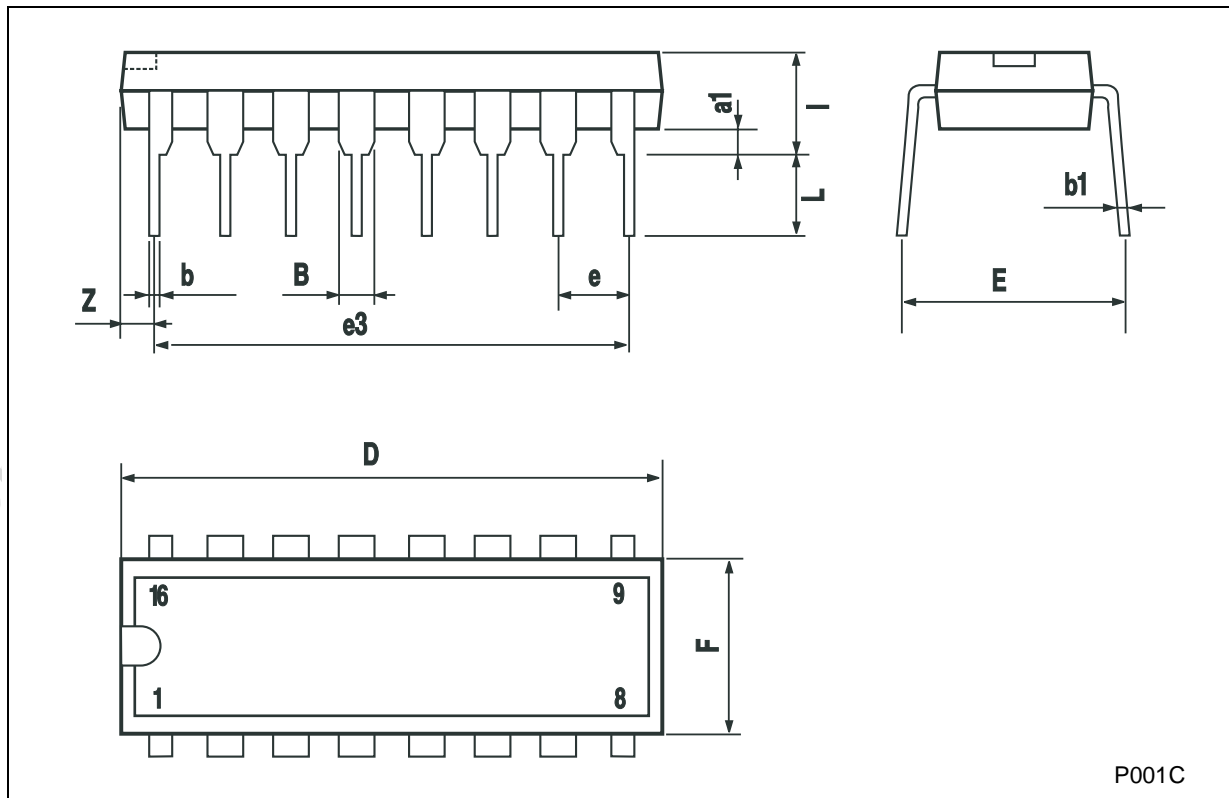

P001C

SO-16 MECHANICAL DATA

DIM.	mm.			inch		
	MIN.	TYP.	MAX.	MIN.	TYP.	MAX.
A			1.75			0.068
a1	0.1		0.2	0.003		0.007
a2			1.65			0.064
b	0.35		0.46	0.013		0.018
b1	0.19		0.25	0.007		0.010
C		0.5			0.019	
c1	45° (typ.)					
D	9.8		10	0.385		0.393
E	5.8		6.2	0.228		0.244
e		1.27			0.050	
e3		8.89			0.350	
F	3.8		4.0	0.149		0.157
G	4.6		5.3	0.181		0.208
L	0.5		1.27	0.019		0.050
M			0.62			0.024
S	8° (max.)					

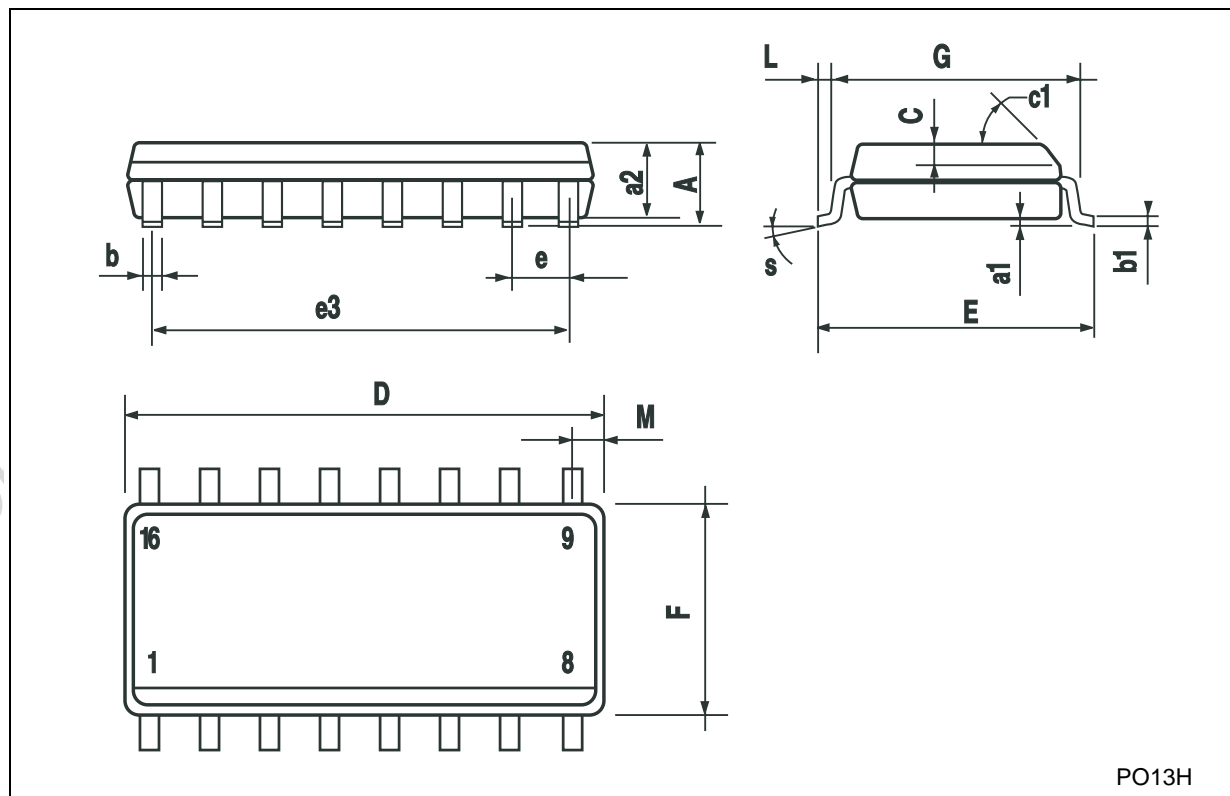

PO13H

Information furnished is believed to be accurate and reliable. However, STMicroelectronics assumes no responsibility for the consequences of use of such information nor for any infringement of patents or other rights of third parties which may result from its use. No license is granted by implication or otherwise under any patent or patent rights of STMicroelectronics. Specifications mentioned in this publication are subject to change without notice. This publication supersedes and replaces all information previously supplied. STMicroelectronics products are not authorized for use as critical components in life support devices or systems without express written approval of STMicroelectronics.

© The ST logo is a registered trademark of STMicroelectronics

© 2002 STMicroelectronics - Printed in Italy - All Rights Reserved
STMicroelectronics GROUP OF COMPANIES

Australia - Brazil - Canada - China - Finland - France - Germany - Hong Kong - India - Israel - Italy - Japan - Malaysia - Malta - Morocco
Singapore - Spain - Sweden - Switzerland - United Kingdom - United States.

© <http://www.st.com>

Obsolete Product(s) - Obsolete Product(s)

Looking for pricing, stock, or lifecycle information?

Click below to explore more details on WIN SOURCE:

- ⊖ [View HCF4054M013TR](#) on WIN SOURCE
- ⊖ [STMicroelectronics](#) Information

Optimize Your Supply Chain with WIN SOURCE Solutions

- ✓ Global Sourcing Solution
- ✓ Obsolete Management
- ✓ Cost Control Management
- ✓ Shortage Management
- ✓ Alternative Solution
- ✓ Excess Inventory Management