



**THE DATASHEET OF  
FODM3022R4V**



# FODM3010, FODM3011, FODM3012, FODM3021, FODM3022, FODM3023

## 4-Pin Full Pitch Mini-Flat Package Random-Phase Triac Driver Output Optocouplers

### Features

- Compact 4-pin surface mount package (2.4 mm maximum standoff height)
- Peak blocking voltage  
250V (FODM301X)  
400V (FODM302X)
- Available in tape and reel quantities of 500 and 2500.
- Applicable to Infrared Ray reflow (230°C max, 30 seconds.)
- BSI, CSA and VDE certifications pending
- UL (File# E90700) certified

### Description

The FODM301X and FODM302X series consists of a GaAs infrared emitting diode driving a silicon bilateral switch housed in a compact 4-pin mini-flat package. The lead pitch is 2.54 mm. They are designed for interfacing between electronic controls and power triacs to control resistive and inductive loads for 115V/240V operations.

### Applications

- Industrial controls
- Traffic lights
- Vending machines
- Solid state relay
- Lamp ballasts
- Solenoid/valve controls
- Static AC power switch
- Incandescent lamp dimmers
- Motor control

### Package Dimensions

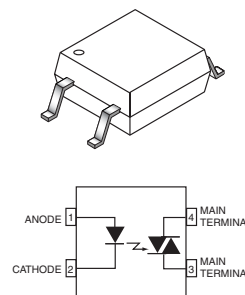
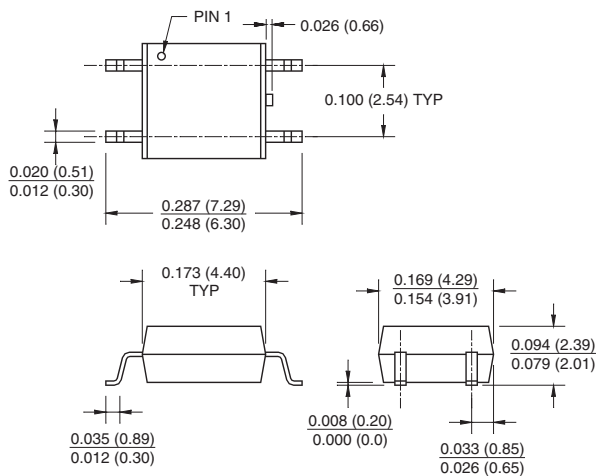

### NOTE

All dimensions are in inches (millimeters)

### Absolute Maximum Ratings ( $T_A = 25^\circ\text{C}$ unless otherwise specified)

Parameter	Symbol	Value	Units	
<b>TOTAL PACKAGE</b>				
Storage Temperature	$T_{STG}$	-40 to +125	$^\circ\text{C}$	
Junction Temperature	$T_J$	125	$^\circ\text{C}$	
Operating Temperature	$T_{OPR}$	-40 to +100	$^\circ\text{C}$	
<b>EMITTER</b>				
Continuous Forward Current	$I_F$ (avg)	60	mA	
Peak Forward Current (1 $\mu\text{s}$ pulse, 300 pps.)	$I_F$ (pk)	1	A	
Reverse Input Voltage	$V_R$	3	V	
Power Dissipation (No derating required over operating temp. range)	$P_D$	100	mW	
<b>DETECTOR</b>				
On-State RMS Current	$I_{T(RMS)}$	70	mA (RMS)	
Off-State Output Terminal Voltage	$V_{DRM}$	FODM3010/1/2	250	V
		FODM3021/2/3	400	
Power Dissipation (No derating required over operating temp. range)	$P_D$	300	mW	

### Electrical Characteristics ( $T_A = 25^\circ\text{C}$ ) Individual Component Characteristics

Parameter	Test Conditions	Symbol	Device	Min	Typ*	Max	Unit
<b>EMITTER</b>							
Input Forward Voltage	$I_F = 10\text{ mA}$	$V_F$	All		1.20	1.5	V
Reverse Leakage Current	$V_R = 3\text{ V}, T_A = 25^\circ\text{C}$	$I_R$	All		0.01	100	$\mu\text{A}$
<b>DETECTOR</b>							
Peak Blocking Current Either Direction	Rated $V_{DRM}, I_F = 0$ (note 1)	$I_{DRM}$	All		2	100	nA
Peak On-State Voltage Either Direction	$I_{TM} = 100\text{mA peak}$	$V_{TM}$	All		1.7	3	V
Critical Rate of Rise of Off-State Voltage	$I_F = 0$ (Figure 8, note 2)	dV/dt	All		10		V/ $\mu\text{s}$

### Transfer Characteristics ( $T_A = 25^\circ\text{C}$ )

DC Characteristics	Test Conditions	Symbol	Device	Min	Typ*	Max	Unit
LED Trigger Current	Main Terminal Voltage = 3V (note 3)	$I_{FT}$	FODM3010			15	mA
			FODM3021				
			FODM3011			10	
			FODM3022				
			FODM3012			5	
			FODM3023				
Holding Current, Either Direction		$I_H$	All		300		$\mu\text{A}$

### Isolation Characteristics

Characteristic	Test Conditions	Symbol	Device	Min	Typ*	Max	Unit
Steady State Isolation Voltage	(1 Minute)	$V_{ISO}$	All	3750			VRMS

\* All typicals at  $T_A = 25^\circ\text{C}$

Note

1. Test voltage must be applied within dv/dt rating.
2. This is static dv/dt. See Figure 1 for test circuit. Commutating dv/dt is function of the load-driving thyristor(s) only.
3. All devices are guaranteed to trigger at an  $I_F$  value less than or equal to max  $I_{FT}$ . Therefore, recommended operating  $I_F$  lies between max  $I_{FT}$  (15 mA for FODM3010 and FODM3021, 10 mA for FODM3011 and FODM3022, 5 mA for FODM3012 and FODM3023) and absolute max  $I_F$  (60 mA).

## Typical Performance Curves

Fig. 1 LED Forward Voltage vs. Forward Current

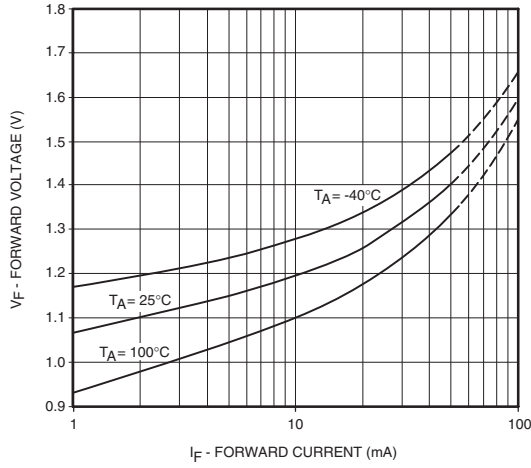

Fig. 2 Leakage Current vs. Ambient Temperature

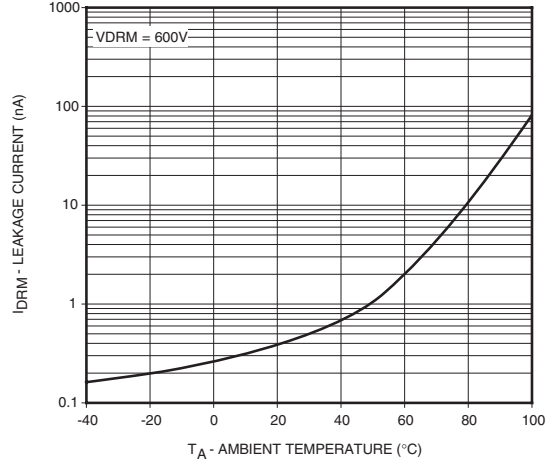

Fig. 3 Holding Current vs. Ambient Temperature

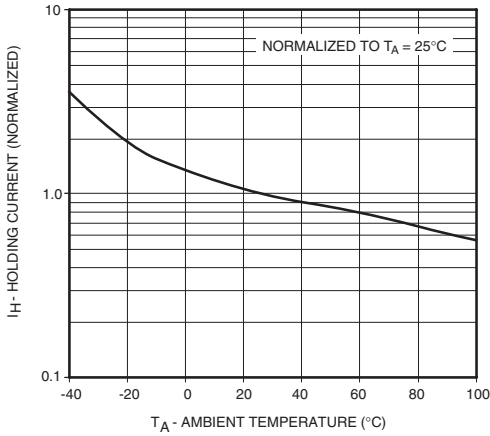
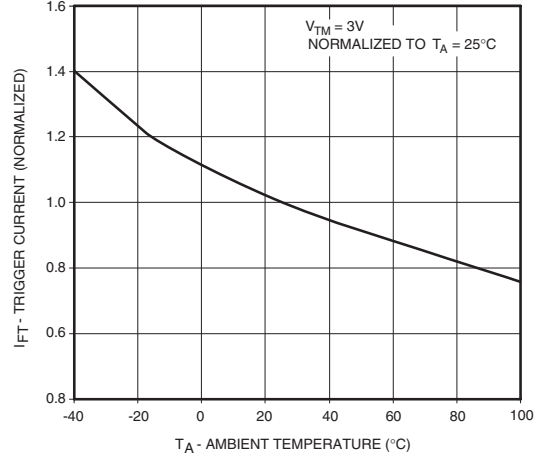

Fig. 4 Trigger Current vs. Ambient Temperature



## Typical Performance Curves

Fig. 5 LED Current Required to Trigger vs. LED Pulse Width

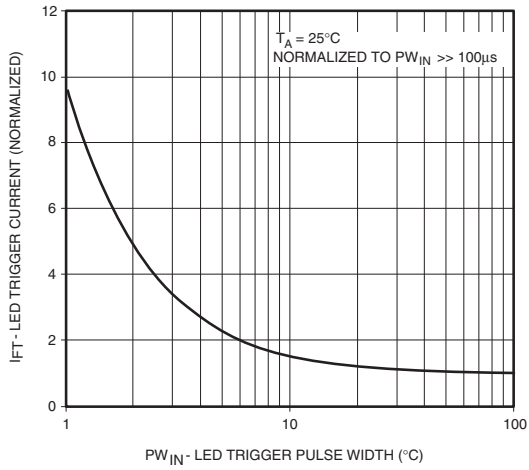

Fig. 6 Off-State Output Terminal Voltage vs. Ambient Temperature

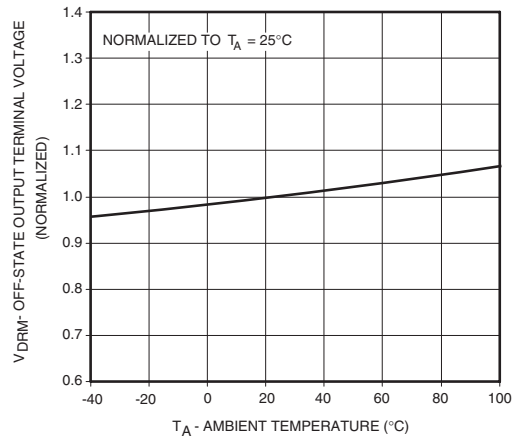
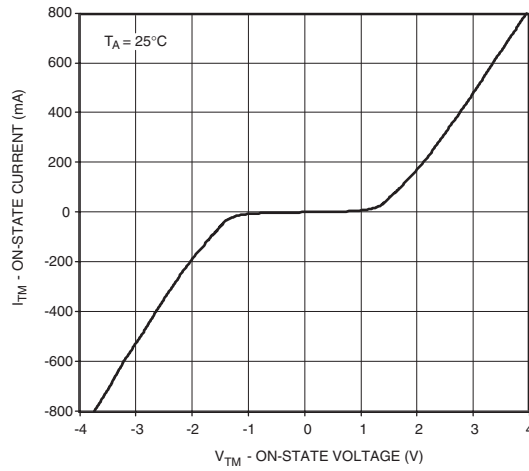

Fig. 7 On-State Characteristics



## Typical Performance Curves

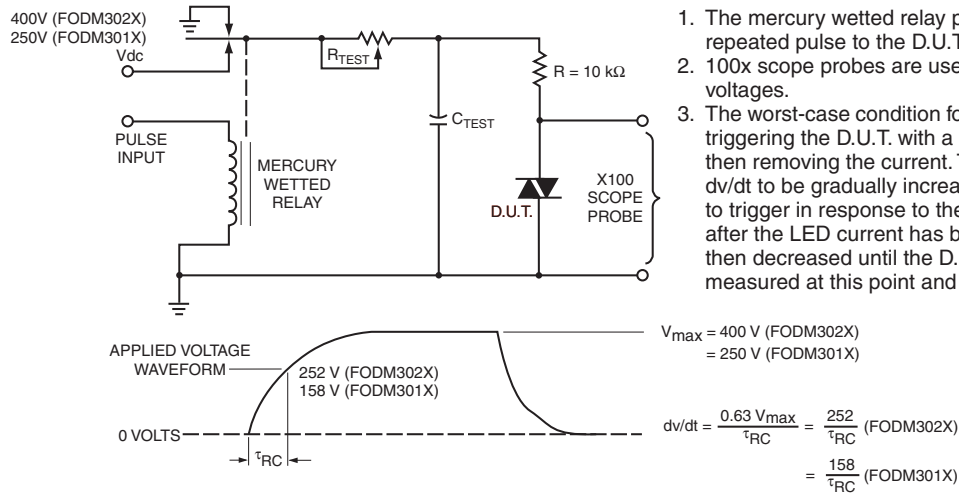

Figure 8. Static dv/dt Test Circuit

NOTE: This optoisolator should not be used to drive a load directly. It is intended to be a trigger device only.

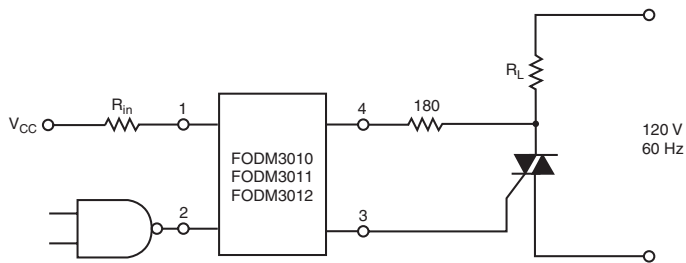

Figure 9. Resistive Load

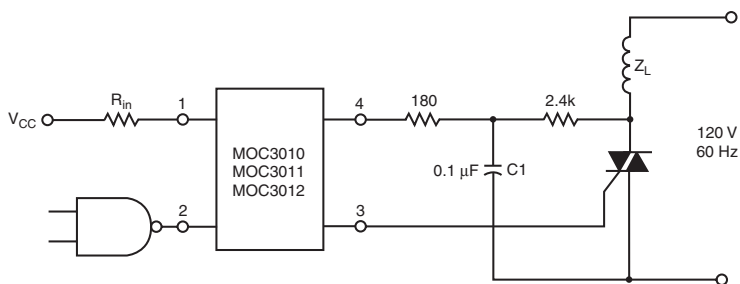
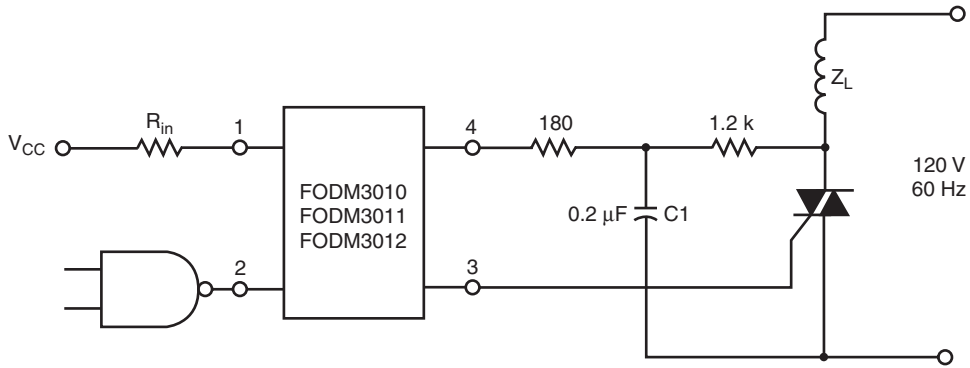
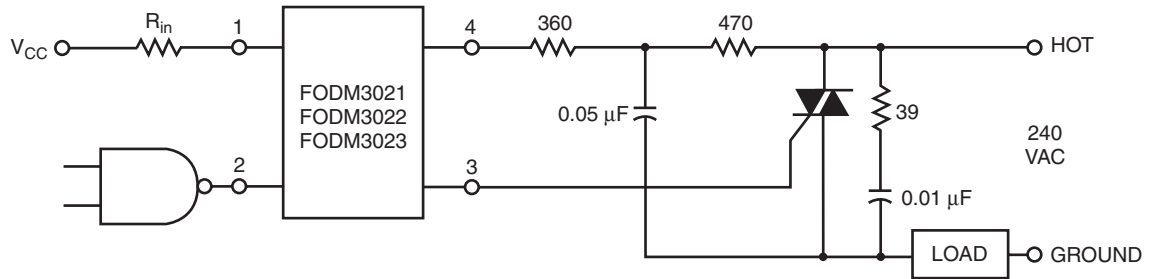

Figure 10. Inductive Load with Sensitive Gate Triac ( $I_{GT} \leq 15 \text{ mA}$ )



**Figure 11. Inductive Load with Sensitive Gate Triac ( $I_{GT} \leq 15 \text{ mA}$ )**



In this circuit the “hot” side of the line is switched and the load connected to the cold or ground side.

The 39 ohm resistor and 0.01  $\mu\text{F}$  capacitor are for snubbing of the triac, and the 470 ohm resistor and 0.05 mF capacitor are for snubbing the coupler. These components may or may not be necessary depending upon the particular and load used.

**Figure 12. Typical Application Circuit**

## Ordering Information

Option	Description
V	VDE Approved
R1	Tape and Reel (500 units)
R2	Tape and Reel (2500 units)
R3	Tape and Reel (500 units; unit 180° rotated)
R4	Tape and Reel (2500 units; unit 180° rotated)
R1V	Tape and Reel (500 units) and VDE Approved
R2V	Tape and Reel (2500 units) and VDE Approved
R3V	Tape and Reel (500 units; unit 180° rotated) and VDE Approved
R4V	Tape and Reel (2500 units; unit 180° rotated) and VDE Approved

## Marking Information

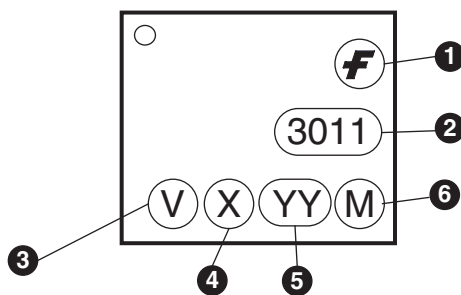

Definitions	
1	Fairchild logo
2	Device number
3	VDE mark (Note: Only appears on parts ordered with VDE option – See order entry table)
4	One digit year code
5	Two digit work week ranging from '01' to '53'
6	Assembly package code

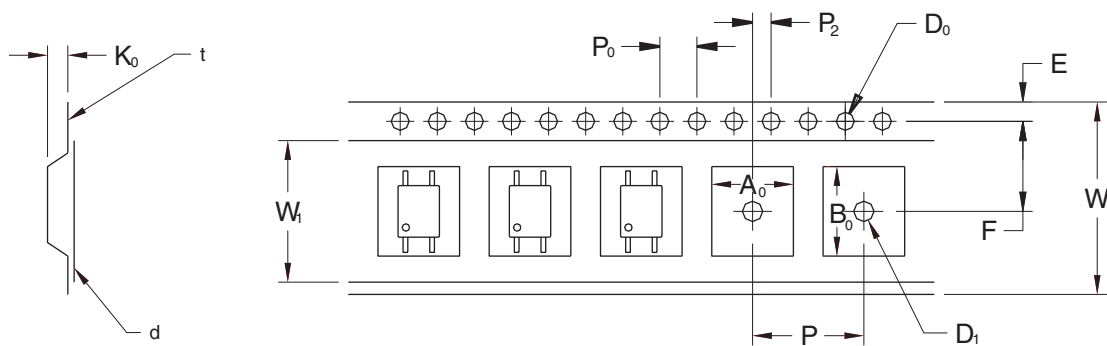

Description		Symbol	2.54 Pitch Dimensions (mm)
Tape Width		W	12.00±0.4
Tape Thickness		t	0.30±0.20
Sprocket Hole Pitch		P <sub>0</sub>	4.00±0.20
Sprocket Hole Dia.		D <sub>0</sub>	1.55±0.20
Sprocket Hole Location		E	1.75±0.20
Pocket Location		F	5.50±0.20
		P <sub>2</sub>	2.00±0.20
Pocket Pitch		P	8.00±0.20
Pocket Dimension		A <sub>0</sub>	4.40±0.20
		B <sub>0</sub>	7.30±0.20
		K <sub>0</sub>	2.30±0.20
Pocket Hole Dia.		D <sub>1</sub>	1.55±0.20
Cover Tape Width		W <sub>f</sub>	9.20
Cover Tape Thickness		d	0.065±0.02
Max. Component Rotation or Tilt			20° max
Devices Per Reel	R1		500
	R2		2500
Reel Diameter	R1		178 mm (7")
	R2		330 mm (13")

### Footprint Drawing for PCB Layout

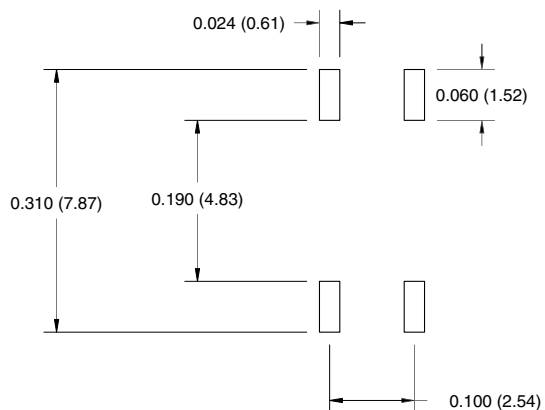

### Recommended Infrared Reflow Soldering Profile

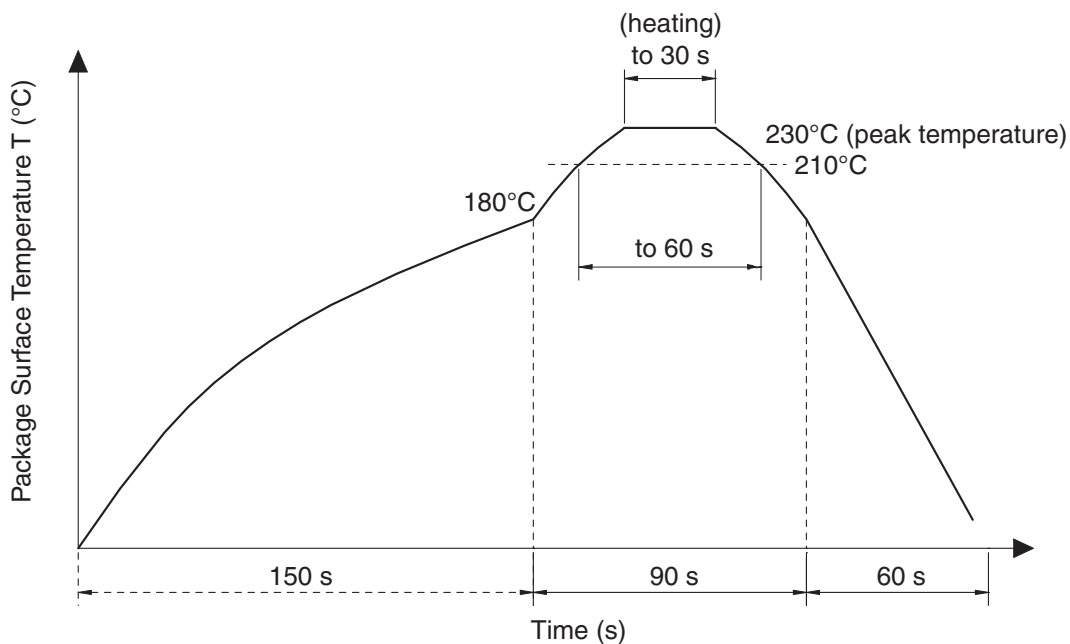

- Peak reflow temperature: 230°C (package surface temperature) for 30 seconds
- Time of temperature higher than 210°C: 60 seconds or less
- One time soldering reflow is recommended

The following are registered and unregistered trademarks Fairchild Semiconductor owns or is authorized to use and is not intended to be an exhaustive list of all such trademarks.

ACEx™	FAST®	ISOPLANAR™	PowerSaver™	SuperSOT™-8
ActiveArray™	FASTr™	LittleFET™	PowerTrench®	SyncFET™
Bottomless™	FPS™	MICROCOUPLER™	QFET®	TinyLogic®
Build it Now™	FRFET™	MicroFET™	QST™	TINYOPTO™
CoolFET™	GlobalOptoisolator™	MicroPak™	QT Optoelectronics™	TruTranslation™
CROSSVOLT™	GTO™	MICROWIRE™	Quiet Series™	UHC™
DOME™	HiSeC™	MSX™	RapidConfigure™	UltraFET®
EcoSPARK™	I <sup>2</sup> C™	MSXPro™	RapidConnect™	UniFET™
E <sup>2</sup> CMOS™	i-Lo™	OCX™	µSerDes™	VCX™
EnSigna™	ImpliedDisconnect™	OCXPro™	SILENT SWITCHER®	Wire™
FACT™	IntelliMAX™	OPTOLOGIC®	SMART START™	
FACT Quiet Series™		OPTOPLANAR™	SPM™	
Across the board. Around the world.™		PACMAN™	Stealth™	
The Power Franchise®		POP™	SuperFET™	
Programmable Active Droop™		Power247™	SuperSOT™-3	
		PowerEdge™	SuperSOT™-6	

**DISCLAIMER**

FAIRCHILD SEMICONDUCTOR RESERVES THE RIGHT TO MAKE CHANGES WITHOUT FURTHER NOTICE TO ANY PRODUCTS HEREIN TO IMPROVE RELIABILITY, FUNCTION OR DESIGN. FAIRCHILD DOES NOT ASSUME ANY LIABILITY ARISING OUT OF THE APPLICATION OR USE OF ANY PRODUCT OR CIRCUIT DESCRIBED HEREIN; NEITHER DOES IT CONVEY ANY LICENSE UNDER ITS PATENT RIGHTS, NOR THE RIGHTS OF OTHERS.

**LIFE SUPPORT POLICY**

FAIRCHILD'S PRODUCTS ARE NOT AUTHORIZED FOR USE AS CRITICAL COMPONENTS IN LIFE SUPPORT DEVICES OR SYSTEMS WITHOUT THE EXPRESS WRITTEN APPROVAL OF FAIRCHILD SEMICONDUCTOR CORPORATION. As used herein:

- |   |   |
|---|---|
| <p>1. Life support devices or systems are devices or systems which, (a) are intended for surgical implant into the body, or (b) support or sustain life, or (c) whose failure to perform when properly used in accordance with instructions for use provided in the labeling, can be reasonably expected to result in significant injury to the user.</p> | <p>2. A critical component is any component of a life support device or system whose failure to perform can be reasonably expected to cause the failure of the life support device or system, or to affect its safety or effectiveness.</p> |
|---|---|

**PRODUCT STATUS DEFINITIONS**

**Definition of Terms**

Datasheet Identification	Product Status	Definition
Advance Information	Formative or In Design	This datasheet contains the design specifications for product development. Specifications may change in any manner without notice.
Preliminary	First Production	This datasheet contains preliminary data, and supplementary data will be published at a later date. Fairchild Semiconductor reserves the right to make changes at any time without notice in order to improve design.
No Identification Needed	Full Production	This datasheet contains final specifications. Fairchild Semiconductor reserves the right to make changes at any time without notice in order to improve design.
Obsolete	Not In Production	This datasheet contains specifications on a product that has been discontinued by Fairchild semiconductor. The datasheet is printed for reference information only.

Rev. 116

## Looking for pricing, stock, or lifecycle information?

Click below to explore more details on WIN SOURCE:

-  [View FODM3022R4V on WIN SOURCE](#)
-  [Fairchild/ON Semiconductor Information](#)

## Optimize Your Supply Chain with WIN SOURCE Solutions

-  Global Sourcing Solution
-  Obsolete Management
-  Cost Control Management
-  Shortage Management
-  Alternative Solution
-  Excess Inventory Management