Features

- 32-kHz Crystal Oscillator
- 1.1 V to 2.2 V Operating-voltage Range
- Integrated Capacitors for Digital Trimming
- Suitable for up to 12.5 pF Quartz
- Output Pulse Formers
- Mask Options for Motor Period and Pulse Width
- Low Resistance Output for Bipolar Stepping Motor
- Motor Fast-test Function

Description

The e1466D is an integrated circuit in CMOS Silicon Gate Technology for analog clocks. It consists of a 32-kHz oscillator, frequency divider, output pulse formers and push-pull motor drivers. Integrated capacitors are mask-selectable to accommodate the external quartz crystal. Additional capacitance can be selected through pad bonding for trimming the oscillator frequency.



32-kHz Clock CMOS IC with Digital Trimming

e1466D



Pad Configuration

Figure 1. Pinning

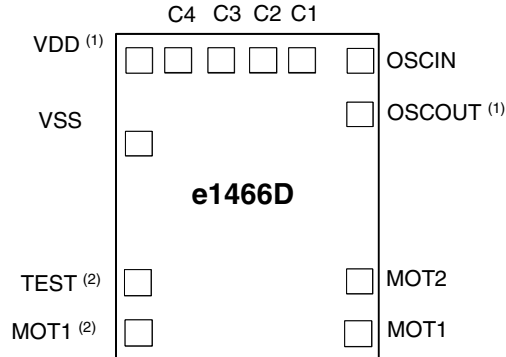

⁽¹⁾ The pads VDD and OSCOUT are interchangeable per mask option

⁽²⁾ The pads TEST and MOT1 are interchangeable per mask option

Pin Description

Name	Description
VDD	Positive supply voltage
VSS	Negative supply voltage
OSCIN	Oscillator input
OSCOUT	Oscillator output
MOT1/2	Motor drive outputs
C1, C2, C3, C4	Oscillator trimming inputs
TEST	TEST input/output

Functional Description

Oscillator

An oscillator inverter with feedback resistor is provided to generate the 32768 Hz clock frequency. Values for the fixed capacitors at OSCIN and OSCOUT are mask-selectable (see note 3 of “Operating Characteristics”). Four capacitor pads, C1 to C4, enable the users to add integrated trimming capacitors to OSCIN, providing 15 tuning steps.

Trimming Capacitors

A frequency variation of typically 4 ppm for each tuning step is obtained by bonding the capacitor pads to OSCIN. As none of these pads are bonded, the IC is in an untrimmed state. Figure 3 shows the trimming curve characteristic.

Note: For applications which utilize this integrated trimming feature, Atmel will determine optimum values for the integrated capacitors COSCIN and COSCOUT.

Capacitor pads C1 to C4: 0 = open, 1 = connected to OSCIN

Combination C1 + C4 is redundant and therefore eliminated from the list

Table 1. Frequency Trimming Table

Capacitor Pads				Trimming Step
C4	C3	C2	C1	
0	0	0	0	0
0	0	0	1	1
0	0	1	0	2
0	1	0	0	3
1	0	0	0	4
0	0	1	1	5
0	1	0	1	6
0	1	1	0	7
1	0	1	0	8
1	1	0	0	9
0	1	1	1	10
1	0	1	1	11
1	1	0	1	12
1	1	1	0	13
1	1	1	1	14

Motor Drive Output

The e1466D contains two push-pull output buffers for driving bipolar stepping motors. During a motor pulse, the N-channel device of one buffer and the P-channel device of the other buffer will be activated. Both N-channel transistors are on and conducting between output pulses. The outputs are protected against inductive voltage spikes with diodes to both supply pins. The motor output period and pulse width are mask-programmable, as listed below:

Available motor periods (T_M): 125, 250, 500 ms and 2, 16 s

Available max. pulse widths (t_M): 15, 6, 23.4, 31.25, 46.9 ms and 1 s

Available motor periods for motor test (T_{MT}): 250, 500 ms and 1 s

Note: The following constraints for combination of motor period and pulse widths have to be considered: $T_M > 4 \times t_M$, $T_{MT} > 4 \times t_M$ or alternatively $T_M = 2 \times t_M$, $T_{MT} = 2 \times t_M$



Test Functions

For test purposes, the TEST pad is open. With a high resistance probe ($R \geq 10 \text{ M}\Omega$, $C \geq 20 \text{ pF}$), a test frequency f_{TEST} of 128 Hz can be measured at the TEST pad. Connecting TEST (for at least 32 ms) to V_{DD} changes the motor period from the selected value to T_{MT} (mask-selectable) while the pulse width remains unaffected. This feature can be used for testing the mechanical parts of the clock.

Absolute Maximum Ratings

Absolute maximum ratings define parameter limits which, if exceeded, may permanently change or damage the device. All inputs and outputs on Atmel's circuits are protected against electrostatic discharges. However, precautions to minimize the build-up of electrostatic charges during handling are recommended.

The circuit is protected against supply voltage reversal for typically 5 minutes.

Parameters	Symbol	Value	Unit
Supply voltage	V_{SS}	-0.3 to 5 V	V
Input voltage range, all inputs	V_{IN}	$(V_{\text{SS}} - 0.3 \text{ V}) \leq V_{\text{IN}} \leq (V_{\text{DD}} + 0.3 \text{ V})$	V
Output short-circuit duration		indefinite	
Power dissipation (DIL package)	P_{tot}	125	mW
Operating ambient temperature range	T_{amb}	-20 to +70	°C
Storage temperature range	T_{stg}	-40 to +125	°C
Lead temperature during soldering at 2 mm distance, 10 s	T_{slid}	260	°C

Operating Characteristics

$V_{SS} = 0\text{ V}$, $V_{DD} = 1.5\text{ V}$, $T_{amb} = +25^\circ\text{C}$, unless otherwise specified.

All voltage levels are measured with reference to V_{SS} . Test crystal as specified below.

Parameters	Test Conditions	Symbol	Min.	Typ.	Max.	Unit
Operating voltage		V_{DD}	1.1	1.5	2.2	V
Operating temperature		T_{amb}	-20		+70	$^\circ\text{C}$
Operating current	$R_1 = \infty$ ⁽²⁾	I_{DD}		2	5	mA
Motor Drive Output						
Motor output current	$V_{DD} = 1.2\text{ V}$, $R_1 = 200\ \Omega$	I_M	± 4.3			mA
Motor period		T_M	See option list			
Motor period during motor test		T_{MT}	See option list			
Motor pulse width		t_M	See option list			
Oscillator						
Startup voltage	Within 2 s	V_{START}	1.2		2.2	V
Frequency stability	$\Delta V_{DD} = 100\text{ mV}$, $V_{DD} = 1.1\text{ to }2.2\text{ V}$	$\Delta f/f$		1		ppm
Integrated input capacitance	⁽³⁾	C_{OSCIN}	See option list			
Integrated output capacitance		C_{OSCOUT}	See option list			
Integrated capacitance for bond option ⁽⁴⁾		C1		3		pF
		C2		4		pF
		C3		5		pF
		C4		6		pF
TEST Input						
Input current	TEST = V_{DD} peak current	I_{TINH}	0.6	3	10	μA
Input current	TEST = V_{SS} peak current	I_{TINL}	-0.6	-3	-10	μA
Input debounce delay		t_{TIN}	23.4		31.2	ms

- Notes:
1. Typical parameters represent the statistical mean values
 2. See test circuit
 3. Values can be selected in 1 pF steps. A total capacitance ($C_{OSCIN} + C_{OSCOUT}$) of 38 pF is available
 4. These values are valid for 10 pF quartz applications. For $C_L = 12.5\text{ pF}$ these values change to 4.5, 6, 7.5, 9 pF

Figure 2. Functional Test

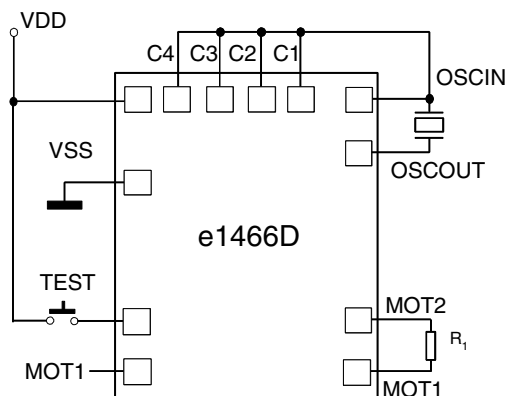

Test Crystal Specification

Oscillation frequency	$f_{OSC} = 32768 \text{ Hz}$
Series resistance	$R_S = 30 \text{ k}\Omega$
Static capacitance	$C_0 = 1.5 \text{ pF}$
Dynamic capacitance	$C_1 = 3.0 \text{ fF}$
Load capacitance	C_L optionally 10 or 12.5 pF

Figure 3. Motor Output Signal During Normal Operation and During Motor Test

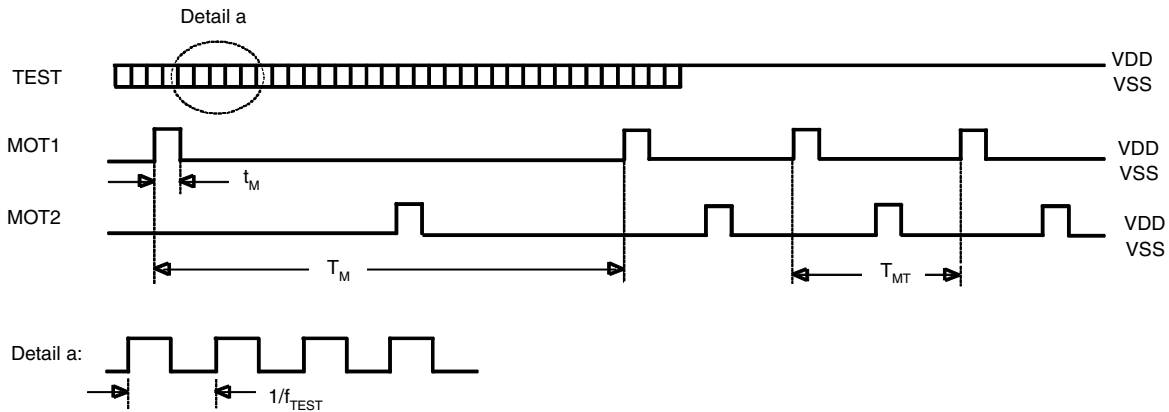
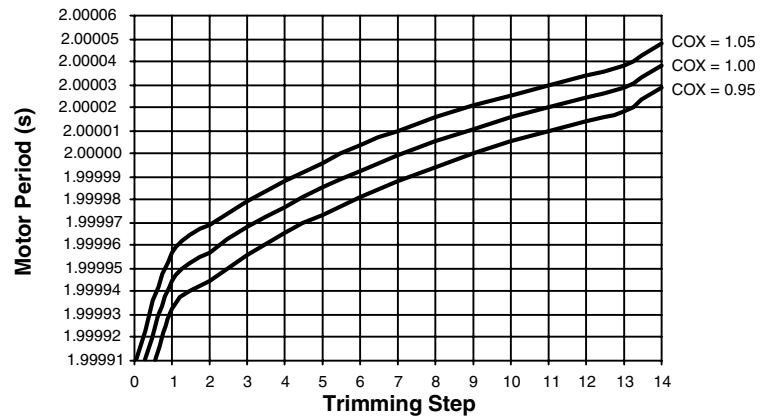

Figure 4. Typical Trimming Curve Characteristic for T_M of 2 s



COX means frequency deviation due to production process variations.

Trimming inputs C1 ... C4 are binary weighted, i.e.,

C1 ... C4 = 0 corresponds to trimming step 0

C1 ... C4 = 1 corresponds to trimming step 15

LSB = C1

Ordering Information

Table 2. Option List e1466Dx

Option	Motor			Integrated Capacitance						Load Capacitance
	Cycle (T _M) s	Pulse (t _M) ms	Test (T _{MT}) ms	C _{OSCIN} ⁽¹⁾ pF	C _{OSCOU} ⁽¹⁾ pF	C1 pF	C2 pF	C3 pF	C4 pF	
A	2	46.9	250	9	20	3	4	5	6	10
AO	2	46.9	250	9	20	3	4	5	6	10
FO	0.25	62.5	2000	9	20	3	4	5	6	10
HO	2	1000	500/ 250	9	20	3	4	5	6	10

Note: 1. On-chip stray capacitance included

Option	Pad Designation											
x	Pad 1	Pad 2	Pad 3	Pad 4	Pad 5	Pad 6	Pad 7	Pad 8	Pad 8	Pad 10	Pad 11	Pad 12
A	OSCIN	OSCOU	MOT2	MOT1	MOT1	TEST	V _{SS}	V _{DD}	C4	C3	C2	C1
AO	OSCIN	OSCOU	MOT2	MOT1	MOT1	TEST	V _{SS}	V _{DD}	C4	C3	C2	C1
FO	OSCIN	OSCOU	MOT2	MOT1	MOT1	TEST	V _{SS}	V _{DD}	C4	C3	C2	C1
HO	OSCIN	OSCOU	MOT2	MOT1	MOT1	TEST	V _{SS}	V _{DD}	C4	C3	C2	C1



Atmel Corporation

2325 Orchard Parkway
San Jose, CA 95131
Tel: 1(408) 441-0311
Fax: 1(408) 487-2600

Regional Headquarters

Europe

Atmel Sarl
Route des Arsenaux 41
Case Postale 80
CH-1705 Fribourg
Switzerland
Tel: (41) 26-426-5555
Fax: (41) 26-426-5500

Asia

Room 1219
Chinachem Golden Plaza
77 Mody Road Tsimshatsui
East Kowloon
Hong Kong
Tel: (852) 2721-9778
Fax: (852) 2722-1369

Japan

9F, Tonetsu Shinkawa Bldg.
1-24-8 Shinkawa
Chuo-ku, Tokyo 104-0033
Japan
Tel: (81) 3-3523-3551
Fax: (81) 3-3523-7581

Atmel Operations

Memory

2325 Orchard Parkway
San Jose, CA 95131
Tel: 1(408) 441-0311
Fax: 1(408) 436-4314

Microcontrollers

2325 Orchard Parkway
San Jose, CA 95131
Tel: 1(408) 441-0311
Fax: 1(408) 436-4314

La Chantrerie
BP 70602
44306 Nantes Cedex 3, France
Tel: (33) 2-40-18-18-18
Fax: (33) 2-40-18-19-60

ASIC/ASSP/Smart Cards

Zone Industrielle
13106 Rousset Cedex, France
Tel: (33) 4-42-53-60-00
Fax: (33) 4-42-53-60-01

1150 East Cheyenne Mtn. Blvd.
Colorado Springs, CO 80906
Tel: 1(719) 576-3300
Fax: 1(719) 540-1759

Scottish Enterprise Technology Park
Maxwell Building
East Kilbride G75 0QR, Scotland
Tel: (44) 1355-803-000
Fax: (44) 1355-242-743

RF/Automotive

Theresienstrasse 2
Postfach 3535
74025 Heilbronn, Germany
Tel: (49) 71-31-67-0
Fax: (49) 71-31-67-2340

1150 East Cheyenne Mtn. Blvd.
Colorado Springs, CO 80906
Tel: 1(719) 576-3300
Fax: 1(719) 540-1759

Biometrics/Imaging/Hi-Rel MPU/ High Speed Converters/RF Datacom

Avenue de Rochepleine
BP 123
38521 Saint-Egreve Cedex, France
Tel: (33) 4-76-58-30-00
Fax: (33) 4-76-58-34-80

e-mail

literature@atmel.com

Web Site

<http://www.atmel.com>

Disclaimer: Atmel Corporation makes no warranty for the use of its products, other than those expressly contained in the Company's standard warranty which is detailed in Atmel's Terms and Conditions located on the Company's web site. The Company assumes no responsibility for any errors which may appear in this document, reserves the right to change devices or specifications detailed herein at any time without notice, and does not make any commitment to update the information contained herein. No licenses to patents or other intellectual property of Atmel are granted by the Company in connection with the sale of Atmel products, expressly or by implication. Atmel's products are not authorized for use as critical components in life support devices or systems.

© Atmel Corporation 2003. All rights reserved.

Atmel® and combinations thereof are the registered trademarks of Atmel Corporation or its subsidiaries.

Other terms and product names may be the trademarks of others.



Printed on recycled paper.

Looking for pricing, stock, or lifecycle information?

Click below to explore more details on WIN SOURCE:

-  [View E1466DAO-DOF on WIN SOURCE](#)
-  [Microchip Technology](#) Information

Optimize Your Supply Chain with WIN SOURCE Solutions

-  Global Sourcing Solution
-  Obsolete Management
-  Cost Control Management
-  Shortage Management
-  Alternative Solution
-  Excess Inventory Management