



**THE DATASHEET OF  
DSA15IM200UC**





# Schottky Diode

$V_{RRM} = 200\text{ V}$

$I_{FAV} = 15\text{ A}$

$V_F = 0.78\text{ V}$

High Performance Schottky Diode  
Low Loss and Soft Recovery  
Single Diode

Part number

**DSA15IM200UC**

Marking on Product: *SFMAUI*

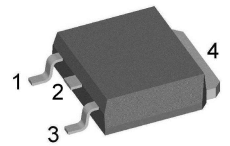

Backside: cathode

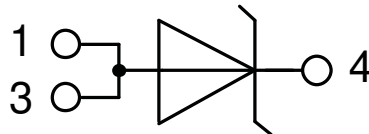

### Features / Advantages:

- Very low  $V_f$
- Extremely low switching losses
- Low  $I_{rm}$  values
- Improved thermal behaviour
- High reliability circuit operation
- Low voltage peaks for reduced protection circuits
- Low noise switching

### Applications:

- Rectifiers in switch mode power supplies (SMPS)
- Free wheeling diode in low voltage converters

### Package: TO-252 (DPak)

- Industry standard outline
- RoHS compliant
- Epoxy meets UL 94V-0

### Disclaimer Notice

Information furnished is believed to be accurate and reliable. However, users should independently evaluate the suitability of and test each product selected for their own applications. Littelfuse products are not designed for, and may not be used in, all applications. Read complete Disclaimer Notice at [www.littelfuse.com/disclaimer-electronics](http://www.littelfuse.com/disclaimer-electronics).



Schottky				Ratings			
Symbol	Definition	Conditions		min.	typ.	max.	Unit
$V_{RSM}$	max. non-repetitive reverse blocking voltage					200	V
$V_{RRM}$	max. repetitive reverse blocking voltage					200	V
$I_R$	reverse current, drain current	$V_R = 200\text{ V}$		$T_{VJ} = 25^\circ\text{C}$		250	$\mu\text{A}$
		$V_R = 200\text{ V}$		$T_{VJ} = 125^\circ\text{C}$		2.5	mA
$V_F$	forward voltage drop	$I_F = 15\text{ A}$		$T_{VJ} = 25^\circ\text{C}$		0.94	V
		$I_F = 30\text{ A}$				1.10	V
		$I_F = 15\text{ A}$		$T_{VJ} = 125^\circ\text{C}$		0.78	V
		$I_F = 30\text{ A}$				0.95	V
$I_{FAV}$	average forward current	$T_C = 150^\circ\text{C}$	rectangular	$T_{VJ} = 175^\circ\text{C}$		15	A
$V_{F0}$	threshold voltage	} for power loss calculation only				0.53	V
$r_F$	slope resistance					10.8	m $\Omega$
$R_{thJC}$	thermal resistance junction to case					2	K/W
$R_{thCH}$	thermal resistance case to heatsink			0.50			K/W
$P_{tot}$	total power dissipation			$T_C = 25^\circ\text{C}$		75	W
$I_{FSM}$	max. forward surge current	$t = 10\text{ ms}; (50\text{ Hz}), \text{ sine}; V_R = 0\text{ V}$		$T_{VJ} = 45^\circ\text{C}$		200	A
$C_J$	junction capacitance	$V_R = 24\text{ V}$	$f = 1\text{ MHz}$	$T_{VJ} = 25^\circ\text{C}$		67	pF



Package TO-252 (DPak)			Ratings			
Symbol	Definition	Conditions	min.	typ.	max.	Unit
$I_{RMS}$	RMS current	per terminal <sup>1)</sup>			20	A
$T_{VJ}$	virtual junction temperature		-55		175	°C
$T_{op}$	operation temperature		-55		150	°C
$T_{stg}$	storage temperature		-55		150	°C
<b>Weight</b>				0.3		g
$F_C$	mounting force with clip		20		60	N

<sup>1)</sup>  $I_{RMS}$  is typically limited by the pin-to-chip resistance (1); or by the current capability of the chip (2). In case of (1) and a product with multiple pins for one chip-potential, the current capability can be increased by connecting the pins as one contact.

**Product Marking**

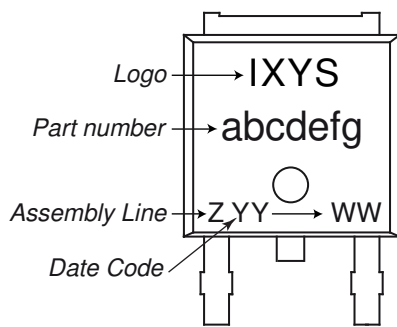

**Part description**

- D = Diode
- S = Schottky Diode
- A = low VF
- 15 = Current Rating [A]
- IM = Single Diode
- 200 = Reverse Voltage [V]
- UC = TO-252AA (DPak)

Ordering	Ordering Number	Marking on Product	Delivery Mode	Quantity	Code No.
Standard	DSA15IM200UC-TRL	SFMAUI	Tape & Reel	2500	510408
Alternative	DSA15IM200UC-TUB	SFMAUI	Tube	70	523494

Similar Part	Package	Voltage class
DSB15IM30UC	TO-252AA (DPak)	30
DSA15IM45UC	TO-252AA (DPak)	45
DSA10IM100UC	TO-252AA (DPak)	100
DSA15IM150UC	TO-252AA (DPak)	150

**Equivalent Circuits for Simulation**

*\* on die level*

$T_{VJ} = 175\text{ °C}$

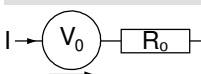

**Schottky**

$V_{0\ max}$	threshold voltage	0.53	V
$R_{0\ max}$	slope resistance *	7.6	mΩ



**Outlines TO-252 (DPak)**

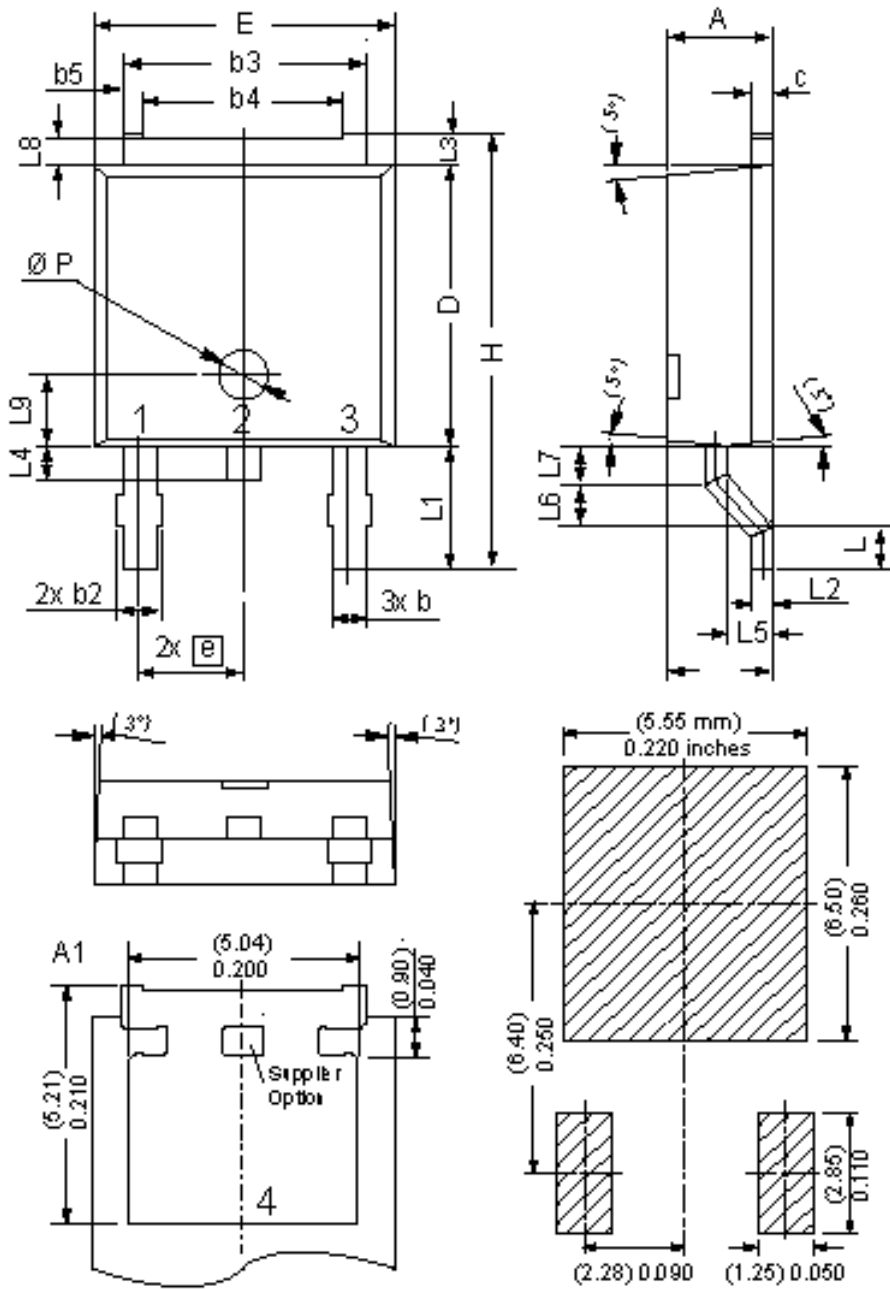

Dim	Millimeters		Inches	
	min	max	min	max
A	2.20	2.40	0.087	0.094
A1	2.10	2.50	0.083	0.098
b	0.66	0.86	0.026	0.034
b2	-	0.96	-	0.038
b3	5.04	5.64	0.198	0.222
b4	4.34	BSC	0.171	BSC
b5	0.50	BSC	0.020	BSC
c	0.40	0.86	0.016	0.034
D	5.90	6.30	0.232	0.248
E	6.40	6.80	0.252	0.268
e	2.10	2.50	0.083	0.098
H	9.20	10.10	0.362	0.398
L	0.55	1.28	0.022	0.050
L1	2.50	2.90	0.098	0.114
L2	0.40	0.60	0.016	0.024
L3	0.50	0.90	0.020	0.035
L4	0.60	1.00	0.024	0.039
L5	0.82	1.22	0.032	0.048
L6	0.79	0.99	0.031	0.039
L7	0.81	1.01	0.032	0.040
L8	0.40	0.80	0.016	0.031
L9	1.50	BSC	0.059	BSC
Ø P	1.00	BSC	0.039	BSC

Recommended  
min. foot print

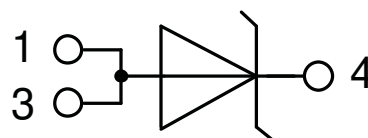



**Schottky**

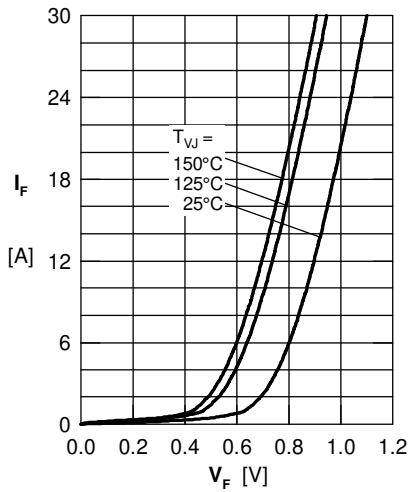

Fig. 1 Maximum forward voltage drop characteristics

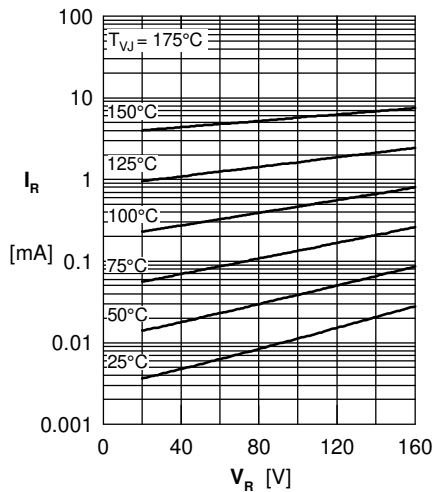

Fig. 2 Typ. reverse current  $I_R$  vs. reverse voltage  $V_R$

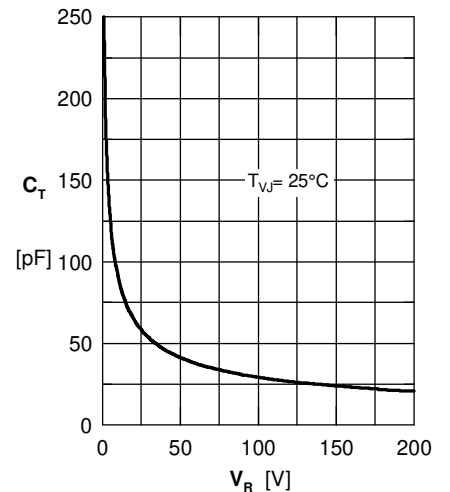

Fig. 3 Typ. junction capacitance  $C_T$  vs. reverse voltage  $V_R$

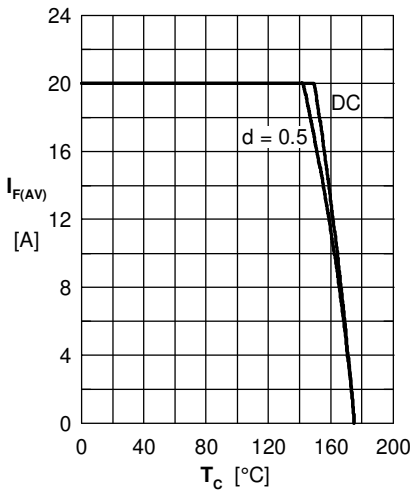

Fig. 4 Avg: forward current  $I_{F(AV)}$  vs. case temperature  $T_C$

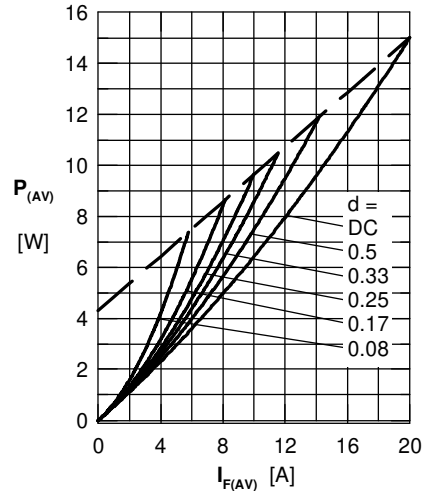

Fig. 5 Forward power loss characteristics

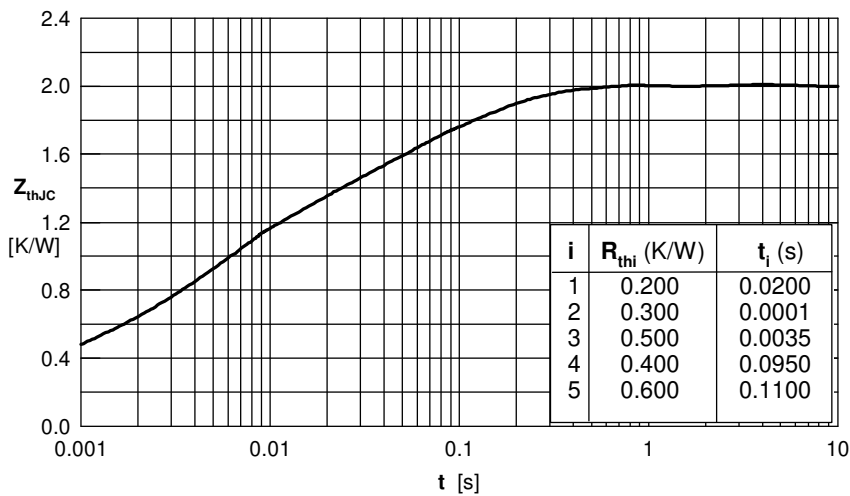

Fig. 6 Transient thermal impedance junction to case

## Looking for pricing, stock, or lifecycle information?

Click below to explore more details on WIN SOURCE:

- ⊖ [View DSA15IM200UC](#) on WIN SOURCE
- ⊖ [IXYS](#) Information

## Optimize Your Supply Chain with WIN SOURCE Solutions

- ✓ Global Sourcing Solution
- ✓ Obsolete Management
- ✓ Cost Control Management
- ✓ Shortage Management
- ✓ Alternative Solution
- ✓ Excess Inventory Management