



**THE DATASHEET OF
A3977KLPTR-T**



Microstepping DMOS Driver with Translator

FEATURES AND BENEFITS

- ± 2.5 A, 35 V output rating
- Low $R_{DS(on)}$ outputs, 0.28 Ω source, 0.22 Ω sink typical
- Automatic current decay mode detection/selection
- 3.0 to 5.5 V logic supply voltage range
- Mixed, fast, and slow current decay modes
- Home output
- Synchronous rectification for low power dissipation
- Internal UVLO and thermal shutdown circuitry
- Crossover-current protection

Package: 28-pin TSSOP (suffix LP) with Exposed Thermal Pad

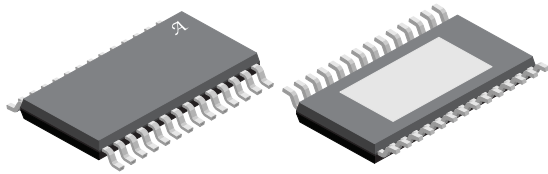

Not to scale

DESCRIPTION

The A3977 is a complete microstepping motor driver with built-in translator. It is designed to operate bipolar stepper motors in full-, half-, quarter-, and eighth-step modes, with output drive capability of 35 V and ± 2.5 A. The A3977 includes a fixed off-time current regulator that has the ability to operate in slow-, fast-, or mixed-decay modes. This current-decay control scheme results in reduced audible motor noise, increased step accuracy, and reduced power dissipation.

The translator is the key to the easy implementation of the A3977. Simply inputting one pulse on the STEP input drives the motor one step (two logic inputs determine if it is a full-, half-, quarter-, or eighth-step). There are no phase-sequence tables, high-frequency control lines, or complex interfaces to program. The A3977 interface is an ideal fit for applications where a complex microprocessor is unavailable or overburdened.

Internal synchronous-rectification control circuitry is provided to improve power dissipation during PWM operation.

Internal circuit protection includes thermal shutdown with hysteresis, undervoltage lockout (UVLO), and crossover-current protection. Special power-up sequencing is not required.

The A3977 is supplied in a thin (< 1.2 mm) 28-pin TSSOP with an exposed thermal pad (suffix LP). The A3977 is lead (Pb) free, with 100% matte tin leadframe plating.

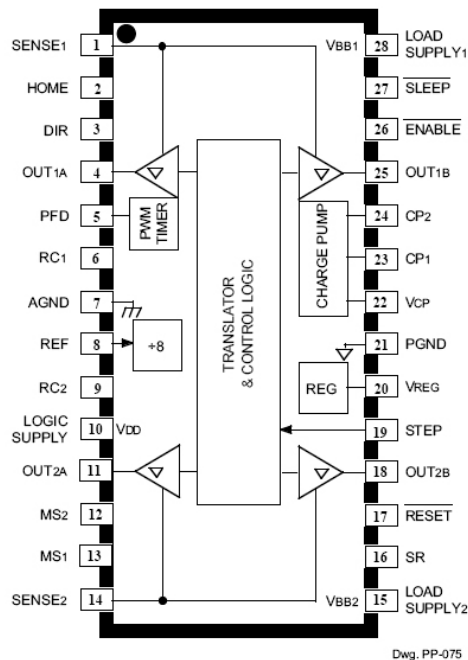

Dwg. PP-075

Pinout Diagram

SPECIFICATIONS

SELECTION GUIDE

Part Number	Packing	Package	Ambient Temperature, T_A (°C)
A3977SLPTR-T	4000 per reel	28-pin TSSOP	-20 to 85

ABSOLUTE MAXIMUM RATINGS

Characteristic	Symbol	Notes	Rating	Units
Load Supply Voltage	V_{BB}		35	V
Logic Supply Voltage	V_{DD}		7.0	V
Logic Input Voltage Range	V_{IN}	Pulsed, $t_w > 30$ ns	-0.3 to $V_{DD} + 0.3$	V
		Pulsed, $t_w < 30$ ns	-1.0 to $V_{DD} + 1$	V
Reference Voltage	V_{REF}		V_{DD}	V
Sense Voltage (DC)	V_{SENSE}		0.5	V
Output Current	I_{OUT}	Output current rating may be limited by duty cycle, ambient temperature, and heat sinking. Under any set of conditions, do not exceed the specified current rating or a junction temperature of 150°C.	±2.5	A
Operating Ambient Temperature	T_A	Range K	-40 to 125	°C
		Range S	-20 to 85	°C
Maximum Junction Temperature	$T_{J(max)}$		150	°C
Storage Temperature	T_{stg}		-55 to 150	°C

THERMAL CHARACTERISTICS

Characteristic	Symbol	Test Conditions*	Value	Units
Package Thermal Resistance	$R_{\theta JA}$	Package LP, on 4-layer PCB based on JEDEC standard	28	°C/W

*Additional thermal information available on the Allegro website.

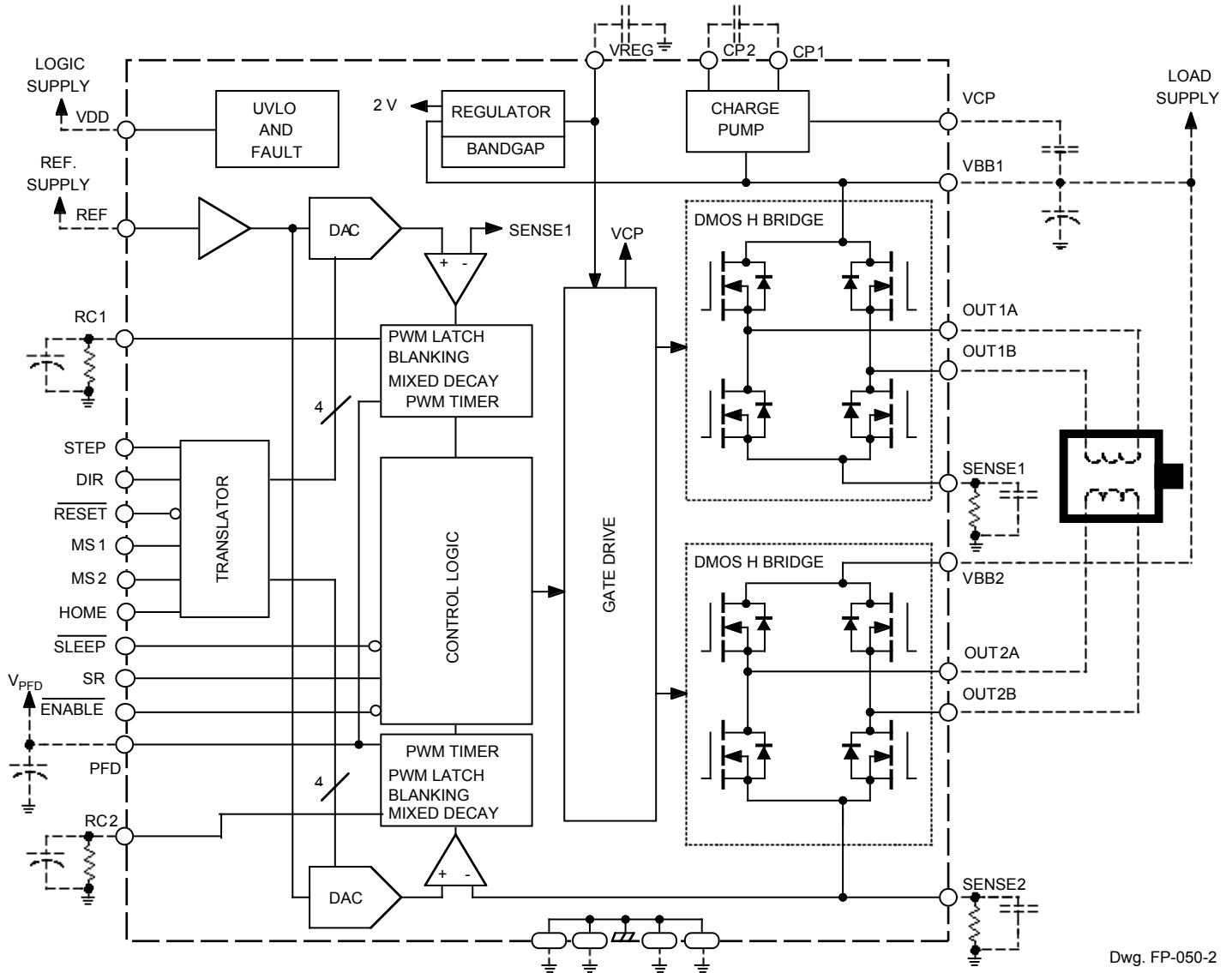

Dwg. FP-050-2

Functional Block Diagram

Pinout Diagram and Terminal List Table

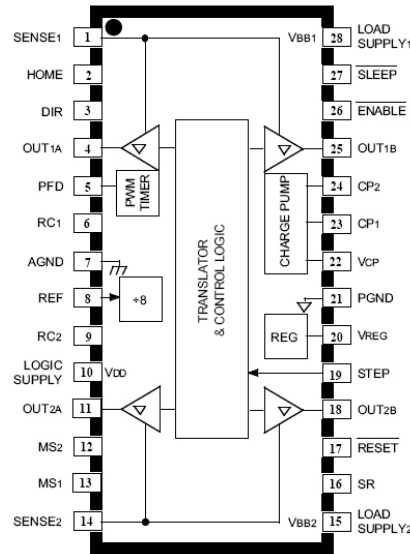

LP Package, 28-Pin TSSOP Pinout Diagram

Terminal List Table

Terminal Name	Terminal Number	Terminal Description
SENSE1	1	Sense Resistor for Bridge 1
HOME	2	Logic Output
DIR	3	Logic Input
OUT1A	4	DMOS H Bridge 1 Output A
PFD	5	Mixed Decay Setting
RC1	6	Analog Input for Fixed Offtime – Bridge 1
AGND	7*	Analog Ground
REF	8	Gm Reference Input
RC2	9	Analog Input for Fixed Offtime – Bridge 2
LOGIC SUPPLY	10	VDD, the Logic Supply Voltage
OUT2A	11	DMOS H Bridge 2 Output A
MS2	12	Logic Input
MS1	13	Logic Input
SENSE2	14	Sense Resistor for Bridge 2

Terminal Name	Terminal Number	Terminal Description
LOAD SUPPLY2	15	VBB2, the Load Supply for Bridge 2
SR	16	Logic Input
RESET	17	Logic Input
OUT2B	18	DMOS H Bridge 2 Output B
STEP	19	Logic Input
VREG	20	Regulator Decoupling
PGND	21*	Power Ground
VCP	22	Reservoir Capacitor
CP1	23	Charge Pump Capacitor
CP2	24	Charge Pump Capacitor
OUT1B	25	DMOS H Bridge 1 Output B
ENABLE	26	Logic Input
SLEEP	27	Logic Input
LOAD SUPPLY1	28	VBB1, the Load Supply for Bridge 1

*AGND and PGND on the TSSOP package must be connected together externally.

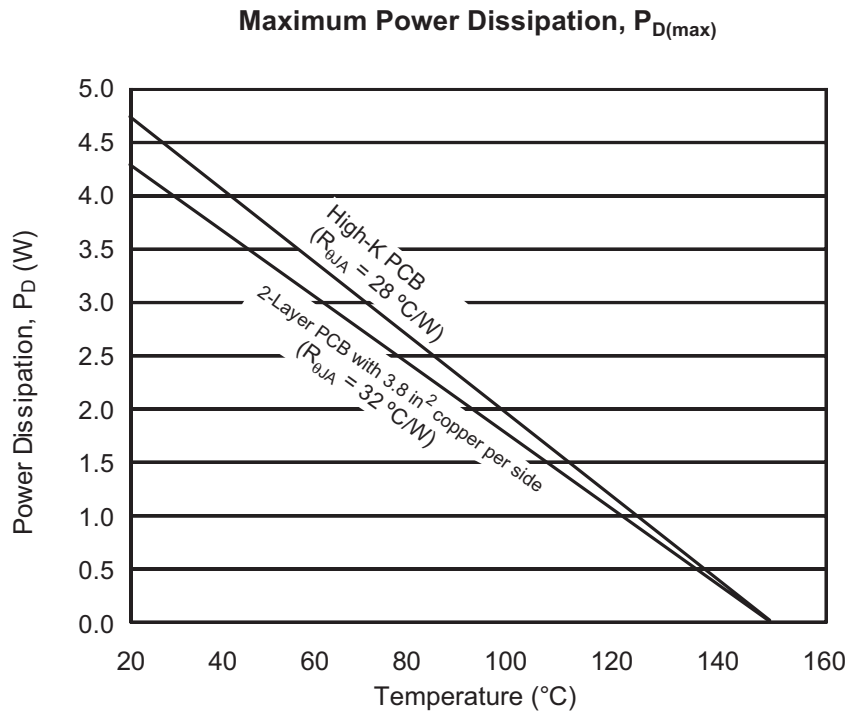

Table 1: Microstep Resolution Truth Table

MS_1	MS_2	Resolution
L	L	Full Step (2 Phase)
H	L	Half Step
L	H	Quarter Step
H	H	Eighth Step

ELECTRICAL CHARACTERISTICS at $T_A = +25^\circ\text{C}$, $V_{BB} = 35\text{ V}$, $V_{DD} = 3.0\text{ to }5.5\text{ V}$ (unless otherwise noted)

Characteristic	Symbol	Test Conditions	Min.	Typ.	Max.	Units
OUTPUT DRIVERS						
Load Supply Voltage Range	V_{BB}	Operating	8.0	–	35	V
		During sleep mode	0	–	35	V
Output Leakage Current	I_{DSS}	$V_{OUT} = V_{BB}$	–	<1.0	20	μA
		$V_{OUT} = 0\text{ V}$	–	<1.0	–20	μA
Output On Resistance	$R_{DS(on)}$	Source driver, $I_{OUT} = -2.5\text{ A}$	–	0.28	0.335	Ω
		Sink driver, $I_{OUT} = 2.5\text{ A}$	–	0.22	0.265	Ω
Body Diode Forward Voltage	V_F	Source diode, $I_F = -2.5\text{ A}$	–	–	1.4	V
		Sink diode, $I_F = 2.5\text{ A}$	–	–	1.4	V
Motor Supply Current	I_{BB}	$f_{PWM} < 50\text{ kHz}$	–	–	8.0	mA
		Operating, outputs disabled	–	–	6.0	mA
		Sleep mode	–	–	20	μA
CONTROL LOGIC						
Logic Supply Voltage Range	V_{DD}	Operating	3.0	5.0	5.5	V
Logic Input Voltage	$V_{IN(1)}$		$0.7 \times V_{DD}$	–	–	V
	$V_{IN(0)}$		–	–	$0.3 \times V_{DD}$	V
Logic Input Current	$I_{IN(1)}$	$V_{IN} = 0.7 \times V_{DD}$	–20	<1.0	20	μA
	$I_{IN(0)}$	$V_{IN} = 0.3 \times V_{DD}$	–20	<1.0	20	μA
Maximum STEP Frequency	f_{STEP}		500*	–	–	kHz
HOME Output Voltage	V_{OH}	$I_{OH} = -200\ \mu\text{A}$	$0.7 \times V_{DD}$	–	–	V
	V_{OL}	$I_{OL} = 200\ \mu\text{A}$	–	–	$0.3 \times V_{DD}$	V
Blank Time	t_{BLANK}	$R_t = 56\text{ k}\Omega$, $C_t = 680\text{ pF}$	700	950	1200	ns
Fixed Off Time	t_{off}	$R_t = 56\text{ k}\Omega$, $C_t = 680\text{ pF}$	30	38	46	μs
Mixed Decay Trip Point	V_{PFDH}		–	$0.6 \times V_{DD}$	–	V
	V_{PFDL}		–	$0.21 \times V_{DD}$	–	V
Reference Input Voltage Range	V_{REF}	Operating	0	–	V_{DD}	V
Reference Input Current	I_{REF}		–	0	± 3.0	μA
Gain (g_m) Error (note 3)	E_G	$V_{REF} = 2\text{ V}$, Phase Current = 38.27%	–	–	± 10	%
		$V_{REF} = 2\text{ V}$, Phase Current = 70.71%	–	–	± 5.0	%
		$V_{REF} = 2\text{ V}$, Phase Current = 100.00%	–	–	± 5.0	%
Crossover Dead Time	t_{DT}	SR enabled	100	475	800	ns
Thermal Shutdown Temperature	T_J		–	165	–	$^\circ\text{C}$
Thermal Shutdown Hysteresis	ΔT_J		–	15	–	$^\circ\text{C}$
UVLO Enable Threshold	V_{UVLO}	Increasing V_{DD}	2.45	2.7	2.95	V
UVLO Hysteresis	ΔV_{UVLO}		0.05	0.10	–	V
Logic Supply Current	I_{DD}	$f_{PWM} < 50\text{ kHz}$	–	–	12	mA
		Outputs off	–	–	10	mA
		Sleep mode	–	–	20	μA

* Operation at a step frequency greater than the specified minimum value is possible but not warranted.

NOTES:

1. Typical Data is for design information only.
2. Negative current is defined as coming out of (sourcing) the specified device terminal.
3. $E_G = ((V_{REF} / 8) - V_{SENSE}) / (V_{REF} / 8)$

FUNCTIONAL DESCRIPTION

Device Operation

The A3977 is a complete microstepping motor driver with built-in translator for easy operation with minimal control lines. It is designed to operate bipolar stepper motors in full-, half-, quarter- and eighth-step modes. The current in each of the two output full-bridges, all N-channel DMOS, is regulated with fixed off-time pulse-width modulated (PWM) control circuitry. The full-bridge current at each step is set by the value of an external current sense resistor (R_S), a reference voltage (V_{REF}), and the DACs output voltage controlled by the output of the translator.

At power-up or reset, the translator sets the DACs and phase current polarity to initial home state (see figures for home state conditions), and sets the current regulator for both phases to mixed-decay mode. When a step command signal occurs on the STEP input, the translator automatically sequences the DACs to the next level (see Table 2 for the current level sequence and current polarity). The microstep resolution is set by inputs MS_1 and MS_2 as shown in Table 1. If the new DAC output level is lower than the previous level, the decay mode for that full-bridge will be set by the PFD input (fast, slow, or mixed decay). If the new DAC level is higher or equal to the previous level, then the decay mode for that full-bridge will be slow decay. This automatic current-decay selection will improve microstepping performance by reducing the distortion of the current waveform due to the motor BEMF.

Reset Input (\overline{RESET})

The RESET input (active low) sets the translator to a predefined home state (see figures for home state conditions) and turns off all of the DMOS outputs. The HOME output goes low and all STEP inputs are ignored until the RESET input goes high.

Home Output (HOME)

The HOME output is a logic output indicator of the initial state of the translator. At power-up, the translator is reset to the home state (see figures for home state conditions).

Step Input (STEP)

A low-to-high transition on the STEP input sequences the translator and advances the motor one increment. The translator controls the input to the DACs and the direction of current flow in each winding. The size of the increment is determined by the state of inputs MS_1 and MS_2 (see Table 1).

Microstep Select (MS_1 and MS_2)

Input terminals MS_1 and MS_2 select the microstepping format per Table 1. Changes to these inputs do not take effect until the STEP command (see Figure 1).

Direction Input (DIR)

The state of the DIRECTION input will determine the direction of rotation of the motor.

Internal PWM Current Control

Each full-bridge is controlled by a fixed off-time PWM current-control circuit that limits the load current to a desired value (I_{TRIP}). Initially, a diagonal pair of source and sink DMOS outputs are enabled and current flows through the motor winding and R_S . When the voltage across the current-sense resistor equals the DAC output voltage, the current-sense comparator resets the PWM latch, which turns off the source driver (slow-decay mode) or the sink and source drivers (fast- or mixed-decay modes).

The maximum value of current limiting is set by the selection of R_S and the voltage at the V_{REF} input with a transconductance function approximated by:

$$I_{TRIPmax} = V_{REF} / 8 \times R_S$$

The DAC output reduces the V_{REF} output to the current-sense comparator in precise steps (see Table 2 for % $I_{TRIPmax}$ at each step).

$$I_{TRIP} = (\% I_{TRIPmax} / 100) \times I_{TRIPmax}$$

It is critical to ensure that the maximum rating (0.5 V) on the SENSE terminal is not exceeded. For full-step mode, V_{REF} can be applied up to the maximum rating of V_{DD} , because the peak sense value is $0.707 \times V_{REF} / 8$. In all other modes, V_{REF} should not exceed 4 V.

Fixed Off-Time

The internal PWM current-control circuitry uses a one shot to control the time the drivers remain off. The one shot off-time, t_{off} , is determined by the selection of an external resistor (R_T) and capacitor (C_T) connected from the RC timing terminal to ground. The off-time, over a range of values of $C_T = 470$ pF to 1500 pF and $R_T = 12$ k Ω to 100 k Ω is approximated by:

$$t_{off} = R_T \times C_T$$

RC Blanking

In addition to the fixed off-time of the PWM control circuit, the C_T component sets the comparator blanking time. This function blanks the output of the current-sense comparator when the outputs are switched by the internal current-control circuitry. The comparator output is blanked to prevent false over-current detection due to reverse recovery currents of the clamp diodes, and/or switching transients related to the capacitance of the load. The blank time t_{BLANK} can be approximated by:

$$t_{BLANK} = 1400 \times C_T$$

Charge Pump. (CP₁ and CP₂)

The charge pump is used to generate a gate supply greater than V_{BB} to drive the source-side DMOS gates. A 0.22 μ F ceramic capacitor should be connected between CP₁ and CP₂ for pumping purposes. A 0.22 μ F ceramic capacitor is required between V_{CP} and V_{BB} to act as a reservoir to operate the high-side DMOS devices.

V_{REG}

This internally generated voltage is used to operate the sink-side DMOS outputs. The V_{REG} terminal should be decoupled with a 0.22 μ F capacitor to ground. V_{REG} is internally monitored and in the case of a fault condition, the outputs of the device are disabled.

Enable Input (ENABLE)

This active-low input enables all of the DMOS outputs. When logic high the outputs are disabled. Inputs to the translator (STEP, DIRECTION, MS₁, MS₂) are all active independent of the ENABLE input state.

Shutdown

In the event of a fault (excessive junction temperature, or low voltage on V_{CP}) the outputs of the device are disabled until the fault condition is removed. At power up, and in the event of low V_{DD} , the undervoltage lockout (UVLO) circuit disables the drivers and resets the translator to the HOME state.

Sleep Mode (SLEEP)

This active-low control input is used to minimize power consumption when not in use. This disables much of the internal circuitry, including the output DMOS, regulator, and charge pump. A logic high allows normal operation and startup of the device in the home position. When coming out of sleep mode, wait 1 ms before issuing a STEP command to allow the charge pump (gate drive) to stabilize.

Percent Fast Decay Input (PFD)

When a STEP input signal commands a lower output current from the previous step, it switches the output current decay to either slow-, fast-, or mixed-decay depending on the voltage level at the PFD input. If the voltage at the PFD input is greater than $0.6 \times V_{DD}$, then slow-decay mode is selected. If the voltage on the PFD input is less than $0.21 \times V_{DD}$, then fast-decay mode is selected. Mixed decay is between these two levels. This terminal should be decoupled with a 0.1 μ F capacitor.

Mixed Decay Operation

If the voltage on the PFD input is between $0.6 \times V_{DD}$ and $0.21 \times V_{DD}$, the bridge will operate in mixed-decay mode depending on the step sequence (see figures). As the trip point is reached, the device will go into fast-decay mode until the voltage on the RC terminal decays to the voltage applied to the PFD terminal. The time that the device operates in fast decay is approximated by:

$$t_{FD} = R_T \times C_T \times I_n \times (0.6 \times V_{DD} / V_{PFD})$$

After this fast decay portion, t_{FD} , the device will switch to slow-decay mode for the remainder of the fixed off-time period.

Synchronous Rectification

When a PWM off-cycle is triggered by an internal fixed off-time cycle, load current will recirculate according to the decay mode selected by the control logic. The A3977 synchronous rectification feature will turn on the appropriate MOSFETs during the current decay and effectively short out the body diodes with the low $R_{DS(on)}$ driver. This will reduce power dissipation significantly and eliminate the need for external Schottky diodes for most applications.

The synchronous rectification can be set in either active mode or disabled mode.

Active Mode

When the SR input is logic low, active mode is enabled and synchronous rectification will occur. This mode prevents reversal of the load current by turning off synchronous rectification when a zero current level is detected. This prevents the motor winding from conducting in the reverse direction.

Disabled Mode

When the SR input is logic high, synchronous rectification is disabled. This mode is typically used when external diodes are required to transfer power dissipation from the A3977 package to the external diodes.

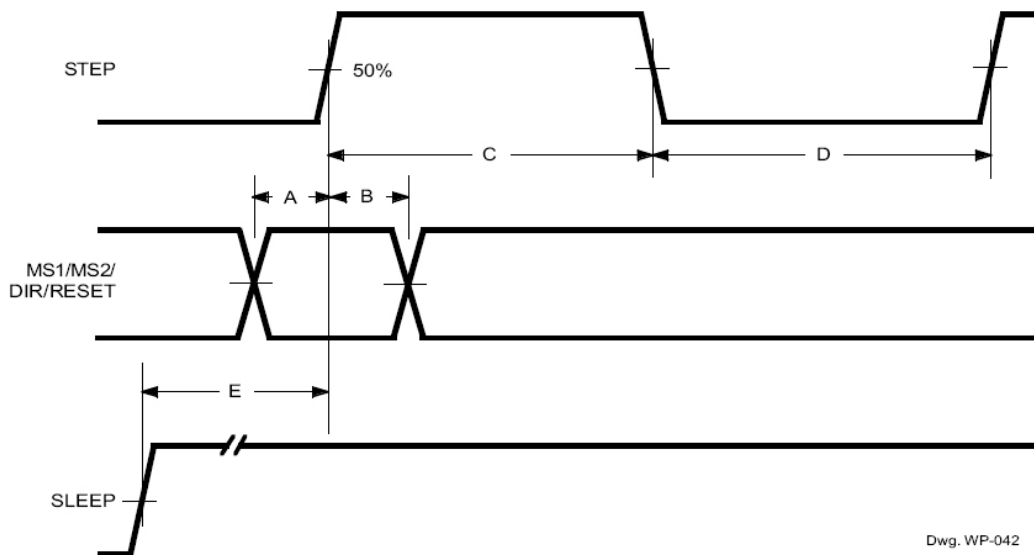

Dwg. WP-042

A. Minimum Command Active Time Before Step Pulse (Data Setup Time)	200 ns
B. Minimum Command Active Time After Step Pulse (Data Hold Time)	200 ns
C. Minimum STEP Pulse Width	1.0 μ s
D. Minimum STEP Low Time	1.0 μ s
E. Maximum Wake-Up Time	1.0 ms

Figure 1: Timing Requirements
 ($T_A = +25^\circ\text{C}$, $V_{DD} = 5\text{ V}$, Logic Levels are V_{DD} and Ground)

APPLICATIONS INFORMATION**Layout**

The printed wiring board should use a heavy ground plane.

For optimum electrical and thermal performance, the driver should be soldered directly onto the board.

The load supply terminal, V_{BB} , should be decoupled with an electrolytic capacitor ($>47 \mu\text{F}$ is recommended) placed as close to the device as possible.

To avoid problems due to capacitive coupling of the high dv/dt switching transients, route the bridge-output traces away from the sensitive logic-input traces. Always drive the logic inputs with a low source impedance to increase noise immunity.

Grounding

A star ground system located close to the driver is recommended.

The analog ground (lead 7) and the power ground (lead 21) must be connected together externally. The copper ground plane located under the exposed thermal pad is typically used as the star ground.

Current Sensing

To minimize inaccuracies caused by ground-trace IR drops in sensing the output current level, the current-sense resistor (R_S) should have an independent ground return to the star ground of the device. This path should be as short as possible. For low-value sense resistors, the IR drops in the printed wiring board sense resistor's traces can be significant and should be taken into account. The use of sockets should be avoided as they can introduce variation in R_S due to their contact resistance.

Allegro MicroSystems recommends a value of R_S given by

$$R_S = 0.5 / I_{TRIPmax}$$

Thermal Protection

Circuitry turns off all drivers when the junction temperature reaches 165°C , typically. It is intended only to protect the device from failures due to excessive junction temperatures and should not imply that output short circuits are permitted. Thermal shutdown has a hysteresis of approximately 15°C .

Table 2: Step Sequencing (DIR = H)

Full Step #	Half Step #	Quarter Step #	Eighth Step #	Phase 1 Current [%I _{trip} max]	Phase 2 Current [%I _{trip} max]	Step Angle (°)
	1	1	1	100.00	0.00	0
			2	98.08	19.51	11.25
		2	3	92.39	38.27	22.50
			4	83.15	55.56	33.75
1*	2*	3*	5*	70.71*	70.71*	45*
			6	55.56	83.15	56.25
		4	7	38.27	92.39	67
			8	19.51	98.08	78.75
	3	5	9	0.00	100.00	90
			10	-19.51	98.08	101.25
		6	11	-38.27	92.39	112.50
			12	-55.56	83.15	123.75
2	4	7	13	-70.71	70.71	135
			14	-83.15	55.56	146.25
		8	15	-92.39	38.27	157.50
			16	-98.08	19.51	168.75
	5	9	17	-100.00	0.00	180
			18	-98.08	-19.51	191.25
		10	19	-92.39	-38.27	202.50
			20	-83.15	-55.56	213.75
3	6	11	21	-70.71	-70.71	225
			22	-55.56	-83.15	236.25
		12	23	-38.27	-92.39	247.50
			24	-19.51	-98.08	258.75
	7	13	25	0.00	-100.00	270
			26	19.51	-98.08	281.25
		14	27	38.27	-92.39	292.50
			28	55.56	-83.15	303.75
4	8	15	29	70.71	-70.71	315
			30	83.15	-55.56	326.25
		16	31	92.39	-38.27	337.50
			32	98.08	-19.51	348.75

*Home state; HOME output low.

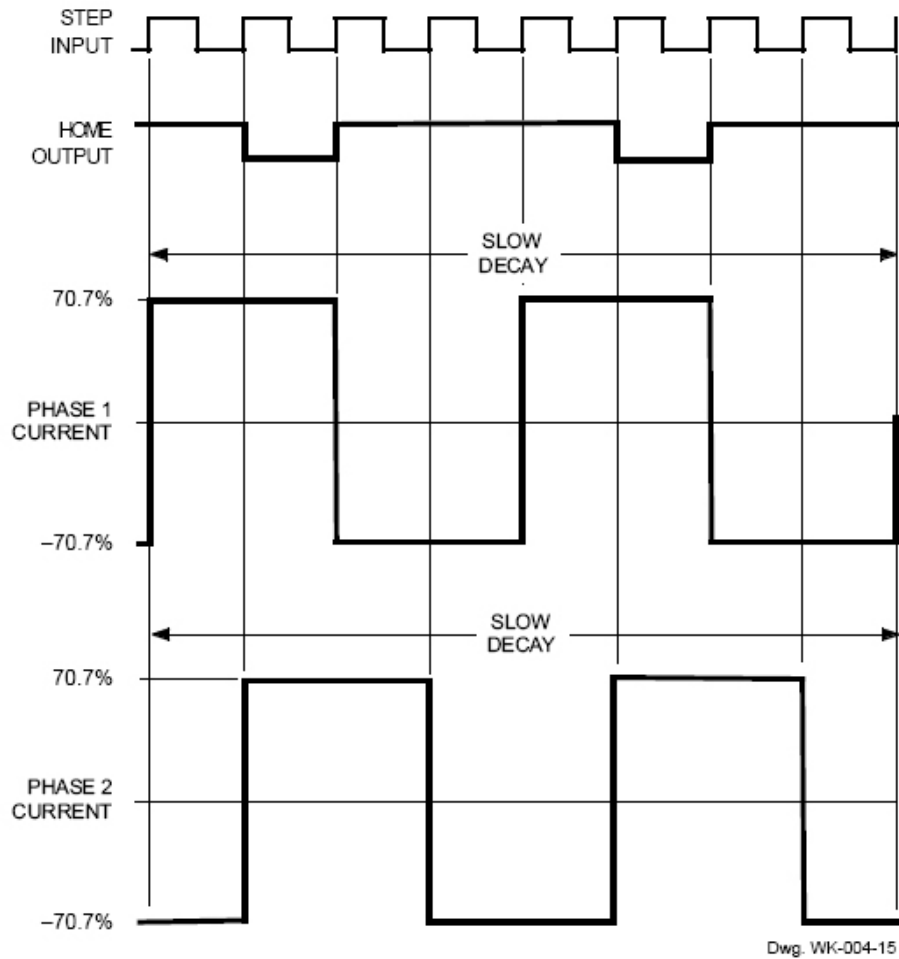
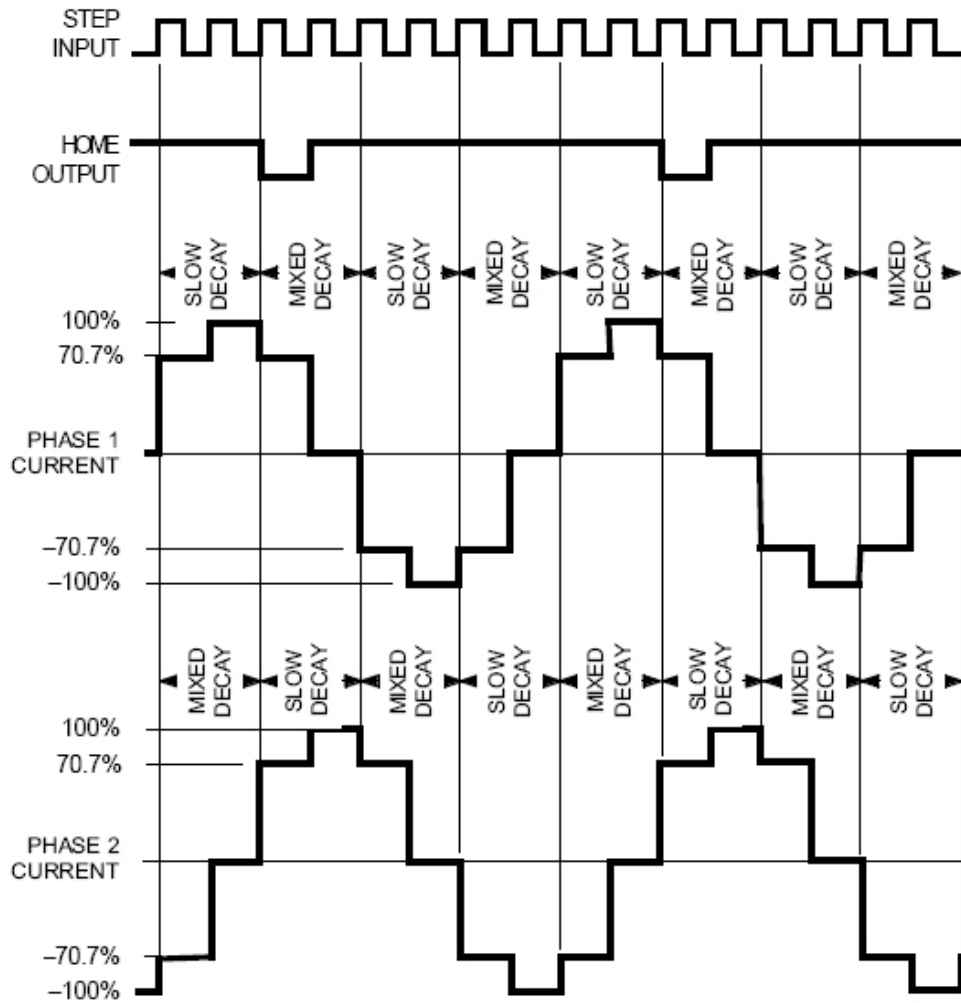

Figure 2: Full-Step Operation
 $MS_1 = MS_2 = L, DIR = H$

The vector addition of the output currents at any step is 100%.



Dwg. WK-004-14

Figure 3: Half-Step Operation
 $MS_1 = H, MS_2 = L, DIR = H$

The mixed-decay mode is controlled by the percent fast decay voltage (V_{PFD}). If the voltage at the PFD input is greater than $0.6 \times V_{DD}$, then slow-decay mode is selected. If the voltage on the PFD input is less than $0.21 \times V_{DD}$, then fast-decay mode is selected. Mixed decay is between these two levels.

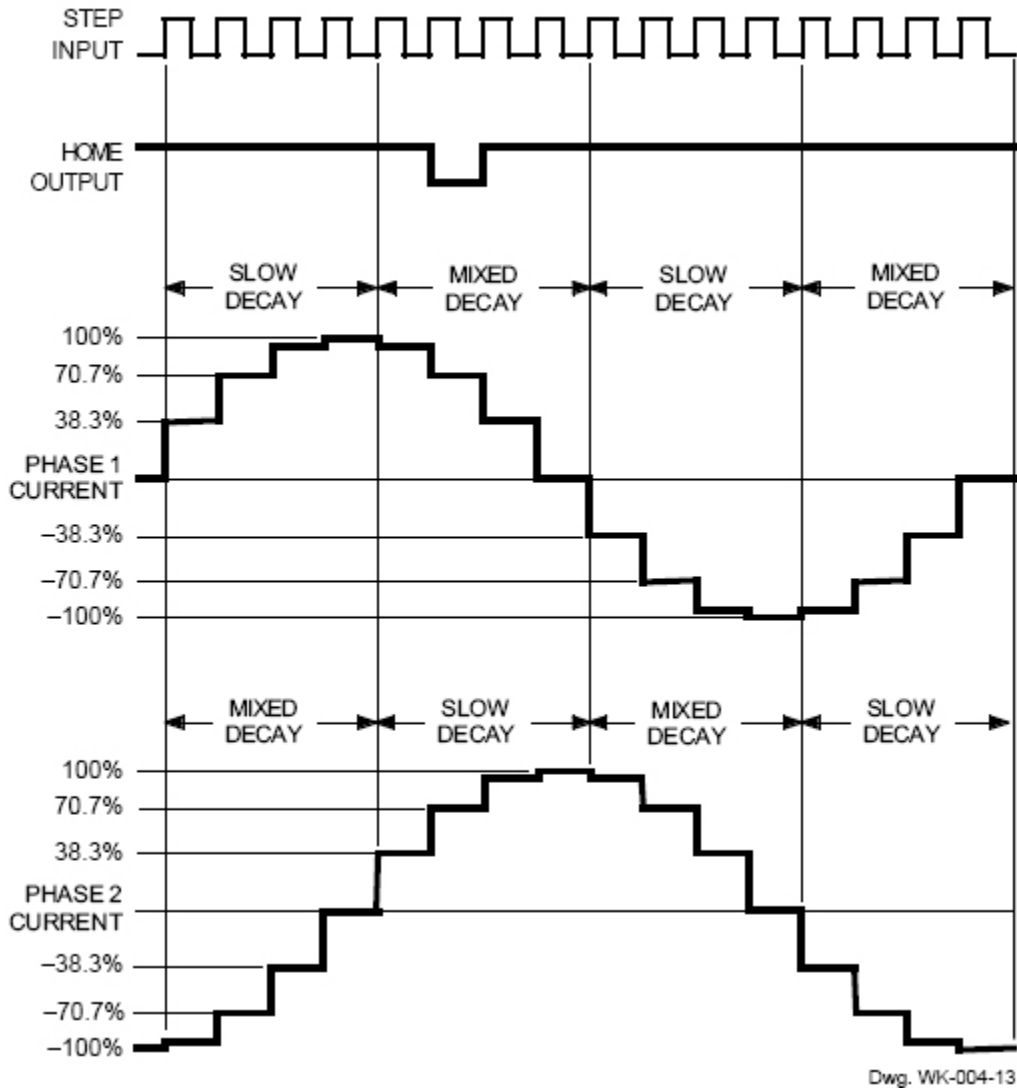

Figure 4: Quarter-Step Operation
 $MS_1 = L$, $MS_2 = H$, $DIR = H$

The mixed-decay mode is controlled by the percent fast decay voltage (V_{PFD}). If the voltage at the PFD input is greater than $0.6 \times V_{DD}$, then slow-decay mode is selected. If the voltage on the PFD input is less than $0.21 \times V_{DD}$, then fast-decay mode is selected. Mixed decay is between these two levels.

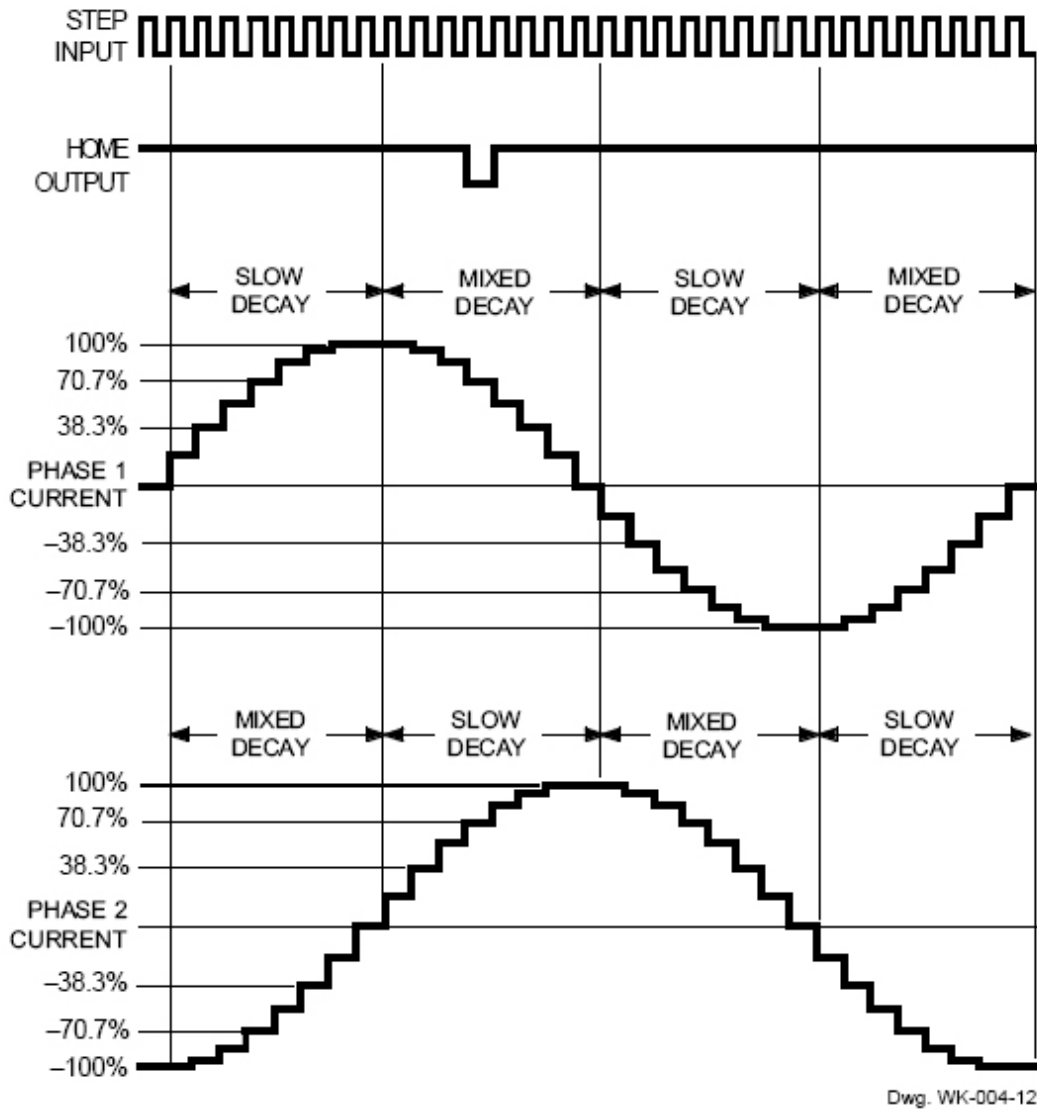

Figure 5: 8 Microstep/Step Operation
 $MS_1 = MS_2 = H, DIR = H$

Dwg. WK-004-12

The mixed-decay mode is controlled by the percent fast decay voltage (V_{PFD}). If the voltage at the PFD input is greater than $0.6 \times V_{DD}$, then slow-decay mode is selected. If the voltage on the PFD input is less than $0.21 \times V_{DD}$, then fast-decay mode is selected. Mixed decay is between these two levels.

CUSTOMER PACKAGE DRAWINGS

For Reference Only – Not for Tooling Use

(Reference MO-153 AET)

Dimensions in millimeters – NOT TO SCALE

Dimensions exclusive of mold flash, gate burrs, and dambar protrusions

Exact case and lead configuration at supplier discretion within limits shown

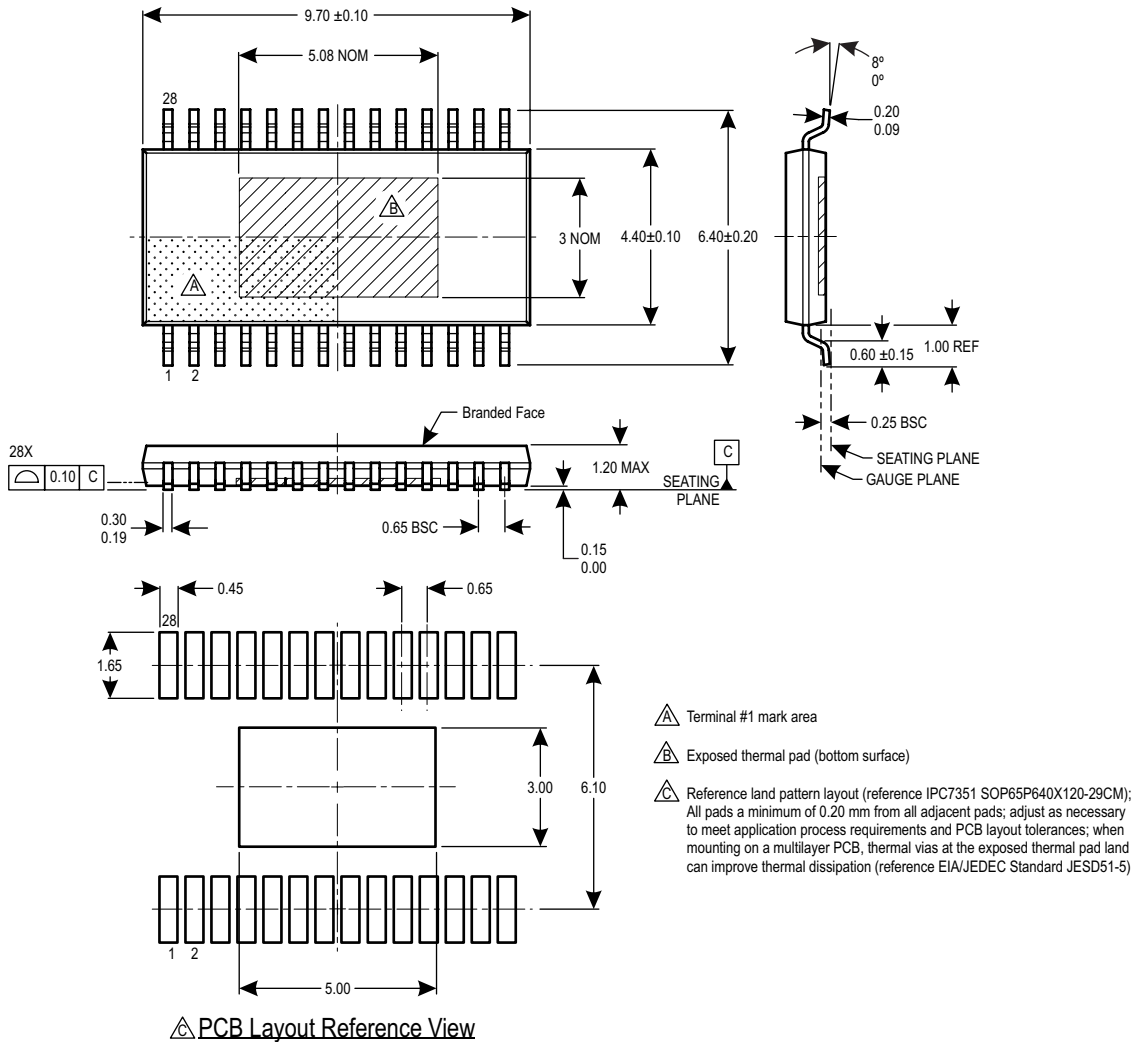

Figure 6: LP Package, 28-pin TSSOP

REVISION HISTORY

Number	Date	Description
11	April 23, 2013	Update product selection and applications component recommendations
12	October 30, 2014	Removed ED package, Revised Table 2 title, reformatted document
13	April 11, 2018	Minor editorial updates
14	April 25, 2019	Minor editorial updates

Copyright 2019, Allegro MicroSystems.

Allegro MicroSystems reserves the right to make, from time to time, such departures from the detail specifications as may be required to permit improvements in the performance, reliability, or manufacturability of its products. Before placing an order, the user is cautioned to verify that the information being relied upon is current.

Allegro's products are not to be used in any devices or systems, including but not limited to life support devices or systems, in which a failure of Allegro's product can reasonably be expected to cause bodily harm.

The information included herein is believed to be accurate and reliable. However, Allegro MicroSystems assumes no responsibility for its use; nor for any infringement of patents or other rights of third parties which may result from its use.

Copies of this document are considered uncontrolled documents.

For the latest version of this document, visit our website:

www.allegromicro.com

Looking for pricing, stock, or lifecycle information?

Click below to explore more details on WIN SOURCE:

- ⊖ [View A3977KLPTR-T on WIN SOURCE](#)
- ⊖ [Allegro MicroSystems, LLC Information](#)

Optimize Your Supply Chain with WIN SOURCE Solutions

- ✓ Global Sourcing Solution
- ✓ Obsolete Management
- ✓ Cost Control Management
- ✓ Shortage Management
- ✓ Alternative Solution
- ✓ Excess Inventory Management