



THE DATASHEET OF MM88C30N



MM88C29 • MM88C30

Quad Single-Ended Line Driver • Dual Differential Line Driver

General Description

The MM88C30 is a dual differential line driver that also performs the dual four-input NAND or dual four-input AND function. The absence of a clamp diode to V_{CC} in the input protection circuitry of the MM88C30 allows a CMOS user to interface systems operating at different voltage levels. Thus, a CMOS digital signal source can operate at a V_{CC} voltage greater than the V_{CC} voltage of the MM88C30 line driver. The differential output of the MM88C30 eliminates ground-loop errors.

The MM88C29 is a non-inverting single-wire transmission line driver. Since the output ON resistance is a low 20Ω typ., the device can be used to drive lamps, relays, solenoids, and clock lines, besides driving data lines.

Features

- Wide supply voltage range: 3V to 15V
- High noise immunity: $0.45 V_{CC}$ (typ.)
- Low output ON resistance: 20Ω (typ.)

Ordering Code:

Order Number	Package Number	Package Description
MM88C29N	N14A	14-Lead Plastic Dual-In-Line Package (PDIP), JEDEC MS-001, 0.300" Wide
MM88C30M	M14A	14-Lead Small Outline Integrated Circuit (SOIC), JEDEC MS-012, 0.150" Narrow
MM88C30N	N14A	14-Lead Plastic Dual-In-Line Package (PDIP), JEDEC MS-001, 0.300" Wide

Devices also available in Tape and Reel. Specify by appending suffix letter "X" to the ordering code.

Connection Diagrams

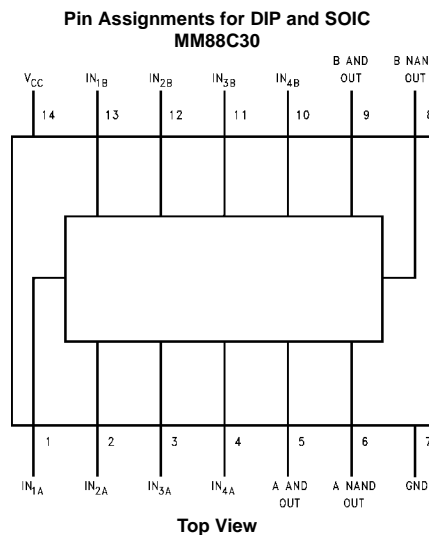
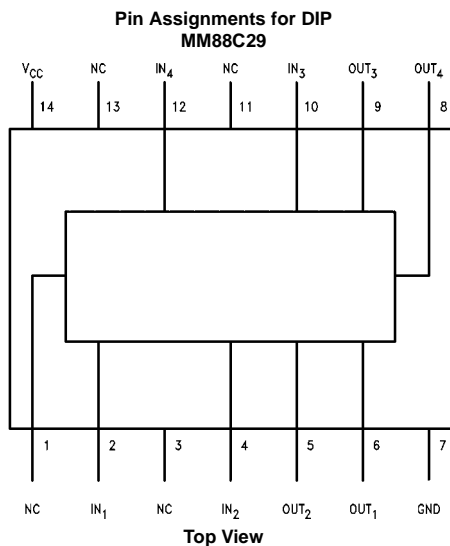

Logic Diagrams

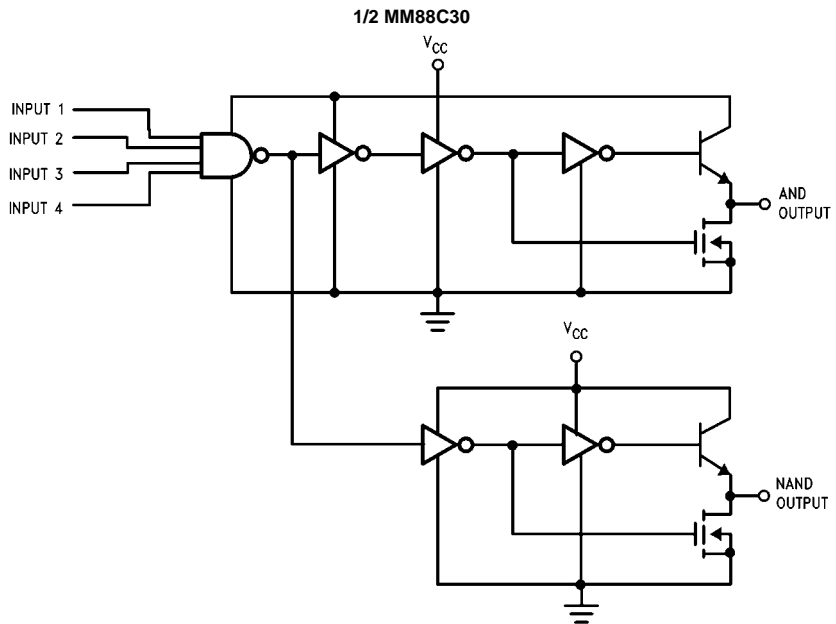
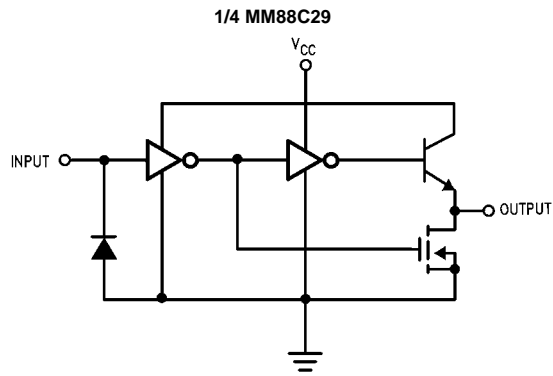

Absolute Maximum Ratings (Note 1)		Average Current at Output	
Voltage at Any Pin (Note 2)	-0.3V to $V_{CC} + 16V$	MM88C30	50 mA
Operating Temperature Range	-40°C to +85°C	MM88C29	25 mA
Storage Temperature	-65°C to +150°C	Maximum Junction Temperature, T_j	150°C
Power Dissipation (P_D)		Lead Temperature	
Dual-In-Line	700 mW	(Soldering, 10 seconds)	260°C
Small Outline	500 mW		
Operating V_{CC} Range	3V to 15V		
Absolute Maximum V_{CC}	18V		

Note 1: "Absolute Maximum Ratings" are those values beyond which the safety of the device cannot be guaranteed. Except for "Operating Temperature Range" they are not meant to imply that the devices should be operated at these limits. The Electrical Characteristics tables provide conditions for actual device operation.

Note 2: AC Parameters are guaranteed by DC correlated testing.

DC Electrical Characteristics

Min/Max limits apply across temperature range unless otherwise noted

Symbol	Parameter	Conditions	Min	Typ	Max	Units
CMOS TO CMOS						
$V_{IN(1)}$	Logical "1" Input Voltage	$V_{CC} = 5V$ $V_{CC} = 10V$	3.5 8			V V
$V_{IN(0)}$	Logical "0" Input Voltage	$V_{CC} = 5V$ $V_{CC} = 10V$			1.5 2	V V
$I_{IN(1)}$	Logical "1" Input Current	$V_{CC} = 15V, V_{IN} = 15V$		0.005	1	μA
$I_{IN(0)}$	Logical "0" Input Current	$V_{CC} = 15V, V_{IN} = 0V$	-1	-0.005		μA
I_{CC}	Supply Current	$V_{CC} = 5V$		0.05	100	mA
OUTPUT DRIVE						
I_{SOURCE}	Output Source Current	$V_{OUT} = V_{CC} - 1.6V,$ $V_{CC} \geq 4.75V, T_j = 25^\circ C$ $T_j = 85^\circ C$	-47 -32	-80 -60		mA mA
		MM88C29 MM88C30	$V_{OUT} = V_{CC} - 0.8V$ $V_{CC} \geq 4.5V$	-2	-20	
I_{SINK}	Output Sink Current	$V_{OUT} = 0.4V, V_{CC} = 4.75V,$ $T_j = 25^\circ C$ $T_j = 85^\circ C$	9.5 8	22 18		mA mA
		$V_{OUT} = 0.4V, V_{CC} = 10V,$ $T_j = 25^\circ C$ $T_j = 125^\circ C$	19 15.5	40 33		mA mA
I_{SOURCE}	Output Source Resistance	$V_{OUT} = V_{CC} - 1.6V,$ $V_{CC} \geq 4.75V, T_j = 25^\circ C$ $T_j = 85^\circ C$		20 27	34 50	Ω Ω
I_{SINK}	Output Sink Resistance	$V_{OUT} = 0.4V, V_{CC} = 4.75V,$ $T_j = 25^\circ C$ $T_j = 85^\circ C$		18 22	41 50	Ω Ω
		$V_{OUT} = 0.4V, V_{CC} = 10V,$ $T_j = 25^\circ C$ $T_j = 85^\circ C$		10 12	21 26	Ω Ω
	Output Resistance Temperature Coefficient			0.55 0.40		$\%/^\circ C$ $\%/^\circ C$
θ_{JA}	Thermal Resistance (N-Package)			150		$^\circ C/W$

AC Electrical Characteristics (Note 2)						
$T_A = 25^\circ\text{C}$, $C_L = 50\text{ pF}$						
Symbol	Parameter	Conditions	Min	Typ	Max	Units
t_{pd}	Propagation Delay Time to Logical "1" or "0" MM88C29	(See Figure 1) $V_{CC} = 5\text{V}$		80	200	ns
		$V_{CC} = 10\text{V}$		35	100	ns
	MM88C30	$V_{CC} = 5\text{V}$		110	350	ns
		$V_{CC} = 10\text{V}$		50	150	ns
t_{pd}	Differential Propagation Delay Time to Logical "1" or "0" MM88C30	$R_L = 100\Omega$, $C_L = 5000\text{ pF}$ (See Figure 2)			400	ns
		$V_{CC} = 10\text{V}$			150	ns
C_{IN}	Input Capacitance MM88C29 MM88C30	(Note 3)		5.0		pF
		(Note 3)		5.0		pF
C_{PD}	Power Dissipation Capacitance MM88C29 MM88C30	(Note 3)		150		pF
		(Note 3)		200		pF

Note 3: Capacitance is guaranteed by periodic testing.

Note 4: C_{PD} determines the no load AC power consumption of any CMOS device. For complete explanation see Family Characteristics application note AN-90 (CMOS Logic Databook).

AC Test Circuits

FIGURE 1.

FIGURE 1.

FIGURE 2.

FIGURE 2.

Typical Applications

Digital Data Transmission

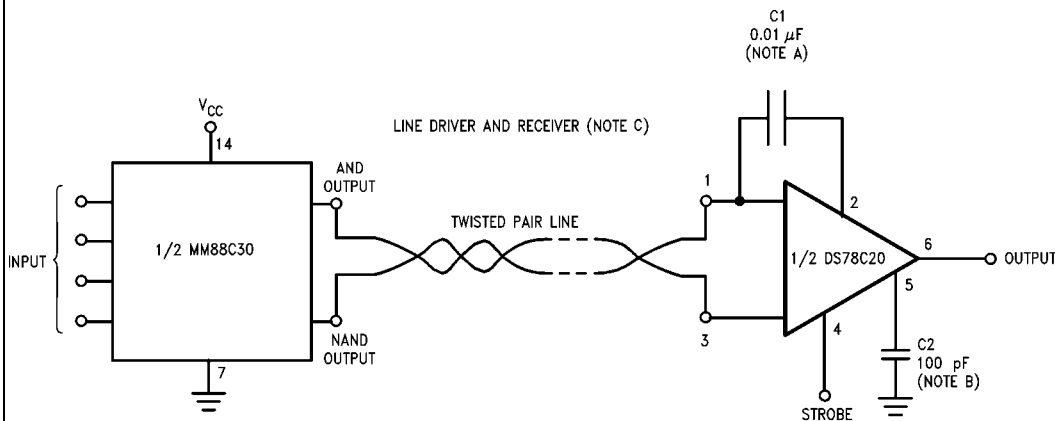

Note A: Exact value depends on line length.
 Note B: Optional to control response time.
 Note C: $V_{CC} = 4.5V$ to $5.5V$ for the DS7820, $V_{CC} = 4.5V$ to $15V$ for the DS78C20.

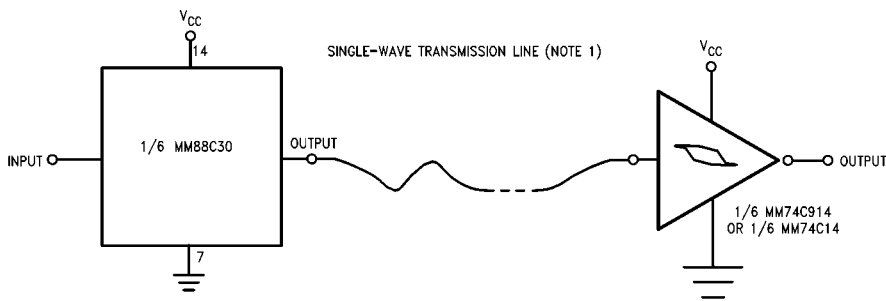
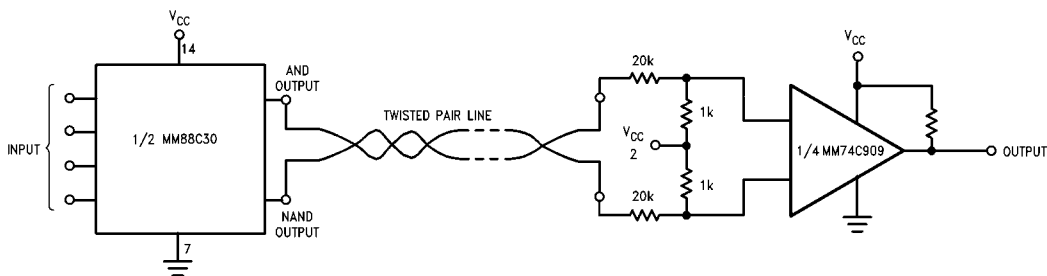

V_{CC} is 3V to 15V.

Typical Data Rate vs Transmission Line Length

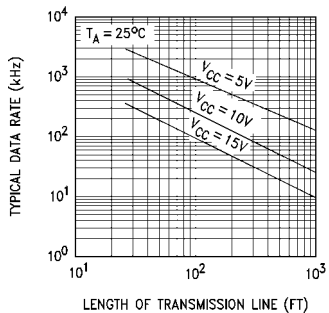

Note: The transmission line used was #22 gauge unshielded twisted pair (40k termination).

Note: The curves generated assume that both drivers are driving equal lines, and that the maximum power is 500 mW/package.

Typical Performance Characteristics

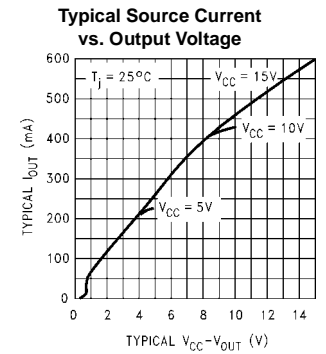
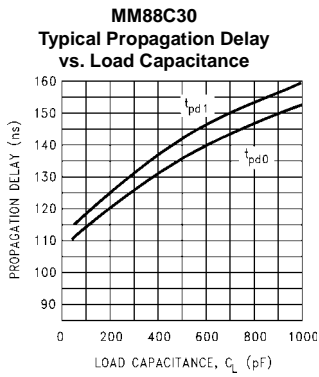
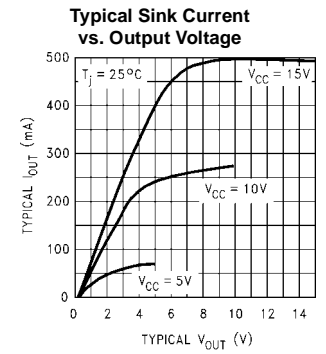
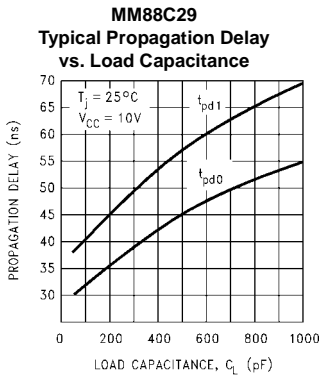
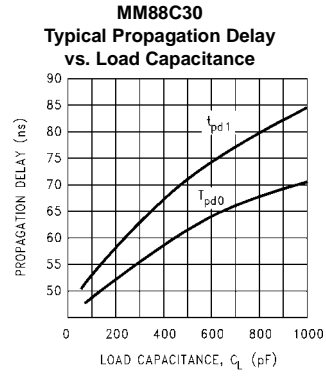
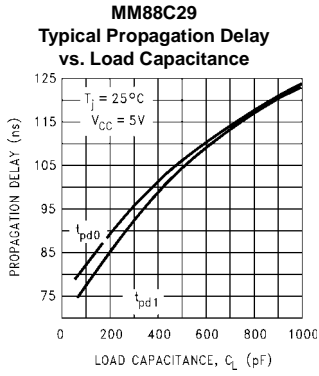

Physical Dimensions inches (millimeters) unless otherwise noted

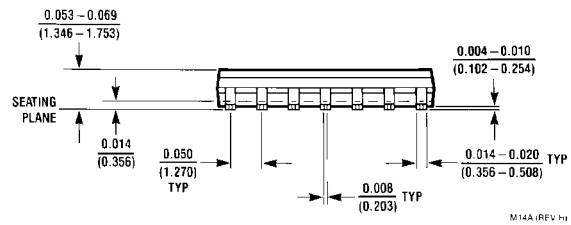
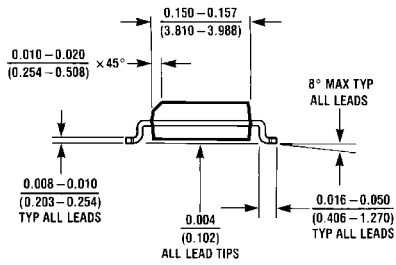
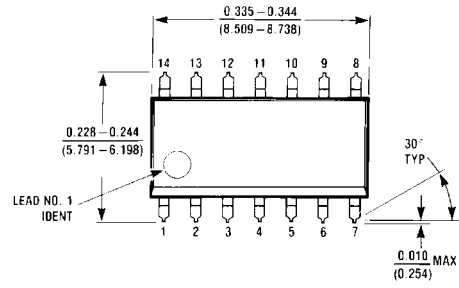

**14-Lead Small Outline Integrated Circuit (SOIC), JEDEC MS-012, 0.150" Narrow
Package Number M14A**

M14A (REV. H)

Physical Dimensions inches (millimeters) unless otherwise noted (Continued)

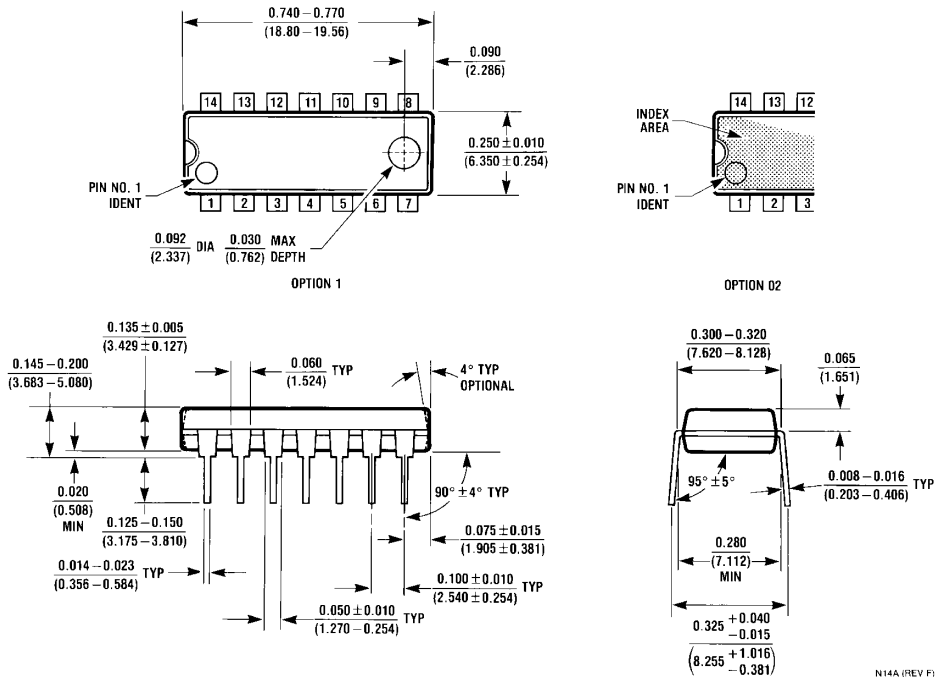

14-Lead Plastic Dual-In-Line Package (PDIP), JEDEC MS-001, 0.300" Wide Package Number N14A

Fairchild does not assume any responsibility for use of any circuitry described, no circuit patent licenses are implied and Fairchild reserves the right at any time without notice to change said circuitry and specifications.

LIFE SUPPORT POLICY



FAIRCHILD'S PRODUCTS ARE NOT AUTHORIZED FOR USE AS CRITICAL COMPONENTS IN LIFE SUPPORT DEVICES OR SYSTEMS WITHOUT THE EXPRESS WRITTEN APPROVAL OF THE PRESIDENT OF FAIRCHILD SEMICONDUCTOR CORPORATION. As used herein:

1. Life support devices or systems are devices or systems which, (a) are intended for surgical implant into the body, or (b) support or sustain life, and (c) whose failure to perform when properly used in accordance with instructions for use provided in the labeling, can be reasonably expected to result in a significant injury to the user.
2. A critical component in any component of a life support device or system whose failure to perform can be reasonably expected to cause the failure of the life support device or system, or to affect its safety or effectiveness.

www.fairchildsemi.com

Looking for pricing, stock, or lifecycle information?

Click below to explore more details on WIN SOURCE:

-  [View MM88C30N on WIN SOURCE](#)
-  [Fairchild/ON Semiconductor Information](#)

Optimize Your Supply Chain with WIN SOURCE Solutions

-  Global Sourcing Solution
-  Obsolete Management
-  Cost Control Management
-  Shortage Management
-  Alternative Solution
-  Excess Inventory Management