

General Description

MIC2569 is designed to supply power to OpenCable™ systems and CableCARD™ hosts. These CableCARDS are also known as Point of Distribution (POD) cards.

MIC2569 supports both Single and Multiple stream cards through a simple to control parallel interface. All voltage switching is soft-start at turn-on, and break-before-make when changing between different voltage supplies.

Built in current limiting protects all V_{CC} and V_{PP} output lines of the host system from card faults and accidental short circuits. MIC2569 provides a FAULT/ signal to indicate an over-current or fault condition exists and is equipped with internal thermal monitoring circuitry to protect the device itself in the event of a sustained over-current condition.

MIC2569 is offered in a space saving 16 pin QSOP packaging.

Data sheets and support documentation can be found on Micrel's web site at www.micrel.com.

Features

- 110 m Ω maximum V_{CC} on resistance
- 400 m Ω maximum V_{PP} on resistance
- 3.0V to 3.6V for the 3.3V_{IN} operating range
- 3.0V to 5.5V for the 5V_{IN} operating range
- 1.3A minimum V_{CC} current limit
- 150mA minimum V_{PP} current limit (150mA each)
- Compact 16-pin QSOP packaging
- Operating temperatures from -40°C to +85°C
- Low quiescent current
- Soft start turn-on
- Break-before-make voltage switching
- Short-circuit protection with thermal shutdown
- Input under voltage lock-out (UVLO)
- ESD protection
- No external components required

Applications

- Satellite / Cable / DVR / Television set top boxes
- Video recorders
- Game consoles

Typical Application

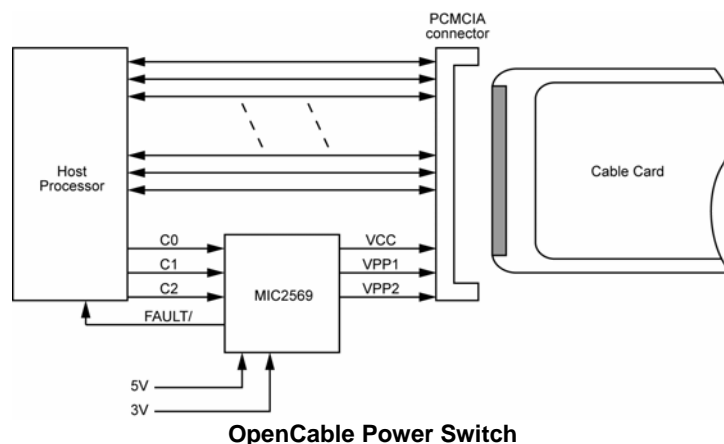

CableCARD is a trademark of CableLabs, Inc.
OpenCable is a trademark of Cable Television Laboratories, Inc.

Micrel Inc. • 2180 Fortune Drive • San Jose, CA 95131 • USA • tel +1 (408) 944-0800 • fax +1 (408) 474-1000 • <http://www.micrel.com>

Ordering Information

Part Number	Marking	Pb-Free	Junction Temp. Range ⁽¹⁾	Package
MIC2569YQS	MIC2569YQS	Yes	-40°C to +85°C	16-pin QSOP

Pin Configuration

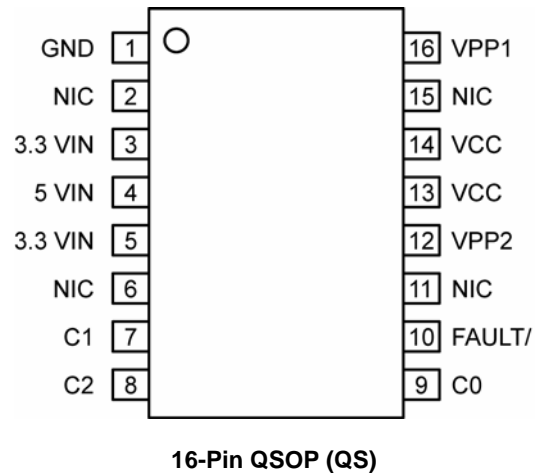

Pin Description

Pin Number	Pin Name	Pin Function
1	GND	Ground.
2	NIC	No internal connection. A voltage or signal applied to this pin will have no effect on device operation.
3	3.3VIN	3V Supply input. Internal chip power is drawn from this supply.
4	5VIN	5V Supply input.
5	3.3VIN	3V Supply input. Note: both 3.3VIN inputs must be powered to insure rated current and R_{ON} is met.
6	NIC	No internal connection. A voltage or signal applied to this pin will have no effect on device operation.
7	C1	Control Pins
		Outputs
		C2 C1 C0 VCC VPP1 VPP2
		0 0 0 3.3 V 3.3 V 3.3 V
		0 0 1 3.3 V 5.0 V 5.0 V
8	C2	0 1 0 Hi-Z Hi-Z Hi-Z
		0 1 1 Hi-Z GND Hi-Z
		1 0 0 3.3 V GND 5.0 V
9	C0	1 0 1 3.3V 5V GND
		1 1 0 3.3V GND GND
		1 1 1 GND GND GND
10	FAULT/	FAULT/ indicates the occurrence of a fault. FAULT/ is an open drain LOW true output and goes low when any supply output is in current limit or if a thermal fault occurs.
11	NIC	No internal connection. A voltage or signal applied to this pin will have no effect on device operation.
12	VPP2	VPP2 output to CableCARD™ card.
13	VCC	VCC (3V main supply) output to CableCARD™ card. Both output pins should be connected together.
14		
15	NIC	No internal connection. A voltage or signal applied to this pin will have no effect on device operation.
16	VPP1	VPP1 output to CableCARD™ card.

Absolute Maximum Ratings⁽¹⁾

Power Supply Voltage	
5VIN	-0.3V to +6.0V
3.3VIN	-0.3V to +3.8V
Voltage on any other pin.....	-0.3V to +6.0V
Continuous Output Current:	
VCC	Internally limited
VPP	Internally limited
Current Into/Out of any control pin:	±10mA
Junction Temperature	150°C
Storage Temperature	-65°C to +150°C

Operating Ratings⁽²⁾

Power Supply Voltage	
5VIN	3.0V to 5.5V
3.3VIN	3.0V to 3.6V
Continuous Output Current	
VCC	3.3A
VPP	450 mA
Ambient Temperature (T _A).....	-40°C to +85°C
Junction Temperature (T _J).....	-40°C to +125°C
Thermal Resistance (θ _{JA}).....	100.8°C/W
Soldering: QSOP Packages	
Infrared (10 to 20 seconds).....	260°C Peak ⁽³⁾

Electrical Characteristics⁽⁴⁾

3.3V_{IN} = 3.3V; 5V_{IN} = 5.0V; T_A = 25°C. Bold values indicate -40°C ≤ T_A ≤ +85°C.

Symbol	Parameter	Condition	Min	Typ	Max	Units		
3.3VIN	Operating input voltage		3.0	3.3	3.6	V		
5VIN	Operating input voltage		3.0	5.0	5.5	V		
I _{VIN}	I _{3.3VIN} Supply Input Current	No Load C2,C1,C0 =	S-Mode	000		140	220	μA
				001		110	200	μA
			M-Mode	010		80	220	μA
				100		100	220	μA
				111		90	180	μA
	I _{5VIN} Supply Input Current	No Load C2,C1,C0 =	S-Mode	000		10	30	μA
				001		50	150	μA
			M-Mode	010		10	220	μA
				100		35	220	μA
				111		10	30	μA
UVLO	Under Voltage Lock Out	3.3VIN rising	2.50	2.76	2.85	V		
		3.3VIN falling	2.45	2.69	2.80	V		
UVLO _{HYS}	Hysteresis			80		mV		
Power Switches								
R _{DS_ON}	R _{ON_VCC} VCC Switch Resistance:	I _{OUT} = 1000 mA		80	110	mΩ		
	R _{ON_VPP1} VPP1 Switch Resistance:	I _{OUT} = 125 mA V _{OUT} = 3.3 V		275	400	mΩ		
		I _{OUT} = 125 mA V _{OUT} = 5.0 V		275	400	mΩ		
I _{LIMIT}	I _{LIMIT_VCC} Output Current Limit: VCC	VCC = 3.3 V	1.3	2.3	3.3	A		
	I _{LIMIT_VPP1} Output Current Limit: VPP ₁	VPP1 = 3.3 V and VPP1 = 5.0 V	150	300	450	mA		

I/O Logic						
Symbol	Parameter	Condition	Min	Typ	Max	Units
V _{IL}	LOW-Level Input Voltage				1	V
V _{IH}	HIGH-Level Input Voltage		2			V
	Input Hysteresis			100		mV
I _{IN_LGC}	Input leakage Current	C2, C1, C0	-1		+1	μA
I _{OFF}	Output OFF leakage current	FAULT/, V _{FAULT/} = 5V		4	10	μA
V _{OL_OD}	Open Drain Output LOW Voltage	FAULT/, I _{SINK} = 1 mA			0.2	V

AC Characteristics

The S-Mode and M-Mode AC Characteristics are not tested in production, specified by design.

Symbol	Parameter	Condition	Min	Typ	Max	Units
t _{D_FAULT/}	Delay before asserting or deasserting FAULT/	Fault on VCC, VPP1, or VPP2	4	12	24	ms

S-Mode						
Symbol	Parameter	Condition	Min	Typ	Max	Units
t _{PWRUP_S-MODE_VCC}	Power-up Rise Time	No Power to VIN Compliance Notes 5 & 6		750		μs
t _{PWRUP_S-MODE_VPP}				800		μs
t _{ON_000-001_VPP}	Output Turn On Delay Time	000 to 001 Notes 8 & 9		800		μs
t _{R_000-001_VPP}	Output Rise Time			800		μs
t _{OFF_001-000_VPP}	Output Turn-Off Delay	001 to 000 Notes 8 & 10		35		μs
t _{F_001-000_VPP}	Output Fall Time			25		μs
t _{OFF_001-110_VPP}	Output Discharge Delay	001 to 110 Notes 8 & 10		35		μs
t _{F_001-110_VPP}	Output Discharge Time			25		μs
t _{ON_110-000_VPP}	Output Turn On Delay Time	110 to 000 Notes 8 & 9		100		μs
t _{R_110-000_VPP}	Output Rise Time			800		μs

M-Mode							
Symbol	Parameter	Condition	Min	Typ	Max	Units	
t _{ON_011-100_VCC}	Output Turn On Delay Time	Notes 5 & 6		50		μs	
t _{R_011-100_VCC}	Output Rise Time		011 to 100		750		μs
t _{ON_011-100_VPP}	Output Turn On Delay Time	Notes 8 & 9			800		μs
t _{R_011-100_VPP}	Output Rise Time				800		μs
t _{OFF_100-010_VCC}	Output Turn-Off Delay	Notes 5 & 7			35		μs
t _{F_100-010_VCC}	Output Fall Time		100 to 010		25		μs
t _{OFF_100-010_VPP}	Output Turn-Off Delay	Notes 8 & 10			35		μs
t _{F_100-010_VPP}	Output Fall Time				25		μs

Symbol	Parameter	Condition		Min	Typ	Max	Units
$t_{\text{OFF}_100-111_VCC}$	Output Discharge Delay	Notes 5 & 7	100 to 111		35		μs
$t_{\text{F}_100-111_VCC}$	Output Discharge Time				25		μs
$t_{\text{OFF}_100-111_VPP}$	Output Discharge Delay	Notes 8 & 10			35		μs
$t_{\text{F}_100-111_VPP}$	Output Discharge Time				25		μs

Notes:

1. Exceeding the absolute maximum rating may damage the device.
2. The device is not guaranteed to function outside its operating rating.
3. Devices are ESD sensitive. Handling precautions recommended. Human body model, 1.5k in series with 100pF.
4. Specification for packaged product only.
5. $R_L = 10\Omega$, $C_L = 1\mu\text{F}$, See Figures 1, 2.
6. Maximum transition time to 3.3 V compliance, from any state including VCC equal to GND.
7. Maximum transition time to GND, from any state including VCC equal to 3.6 V.
8. $R_L = 100\Omega$, $C_L = 0.1\mu\text{F}$, See Figures 1, 2
9. Maximum transition time to 5 V compliance, from any state including VPP equal to GND.
10. Maximum transition time to GND, from any state including VPP equal to 5.5 V.

Timing Diagram

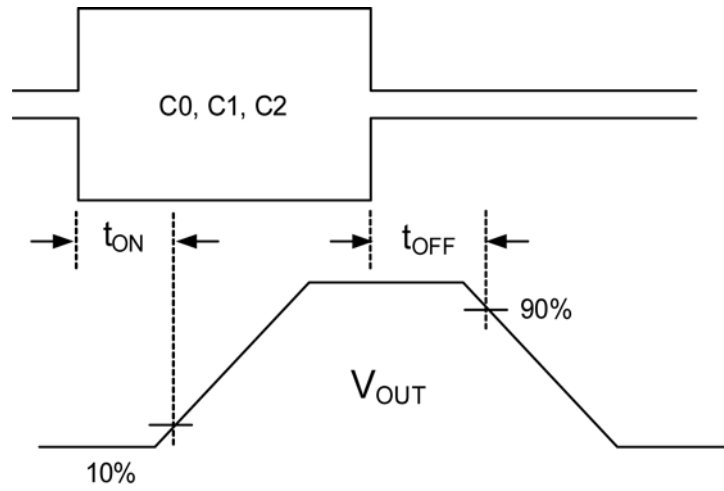

Figure 1. Turn-On and Turn-Off Delay

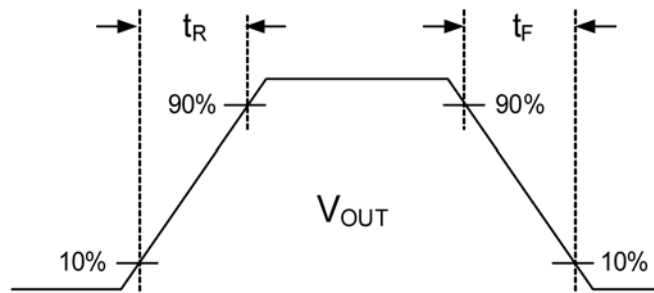
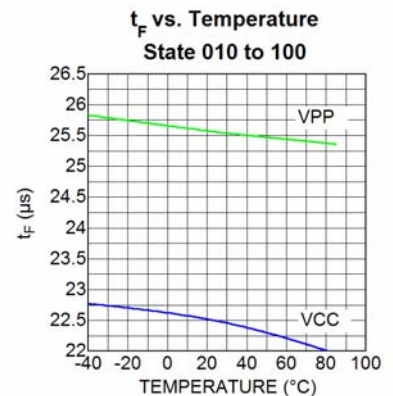
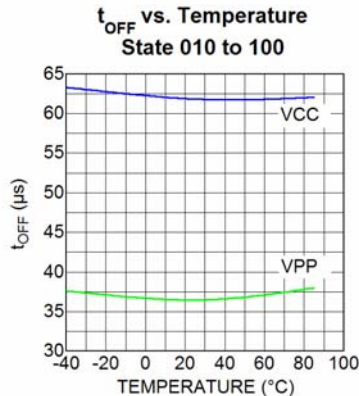
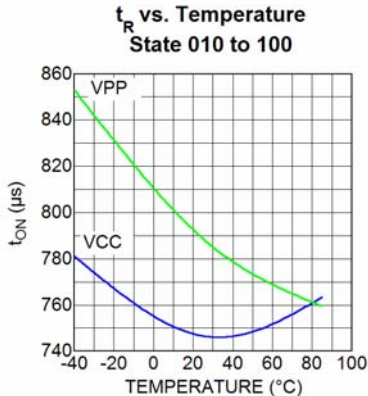
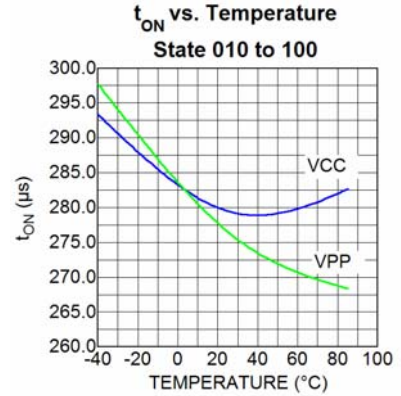
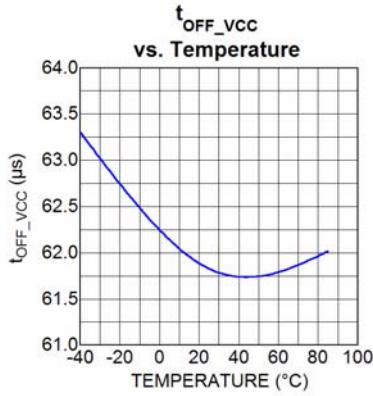
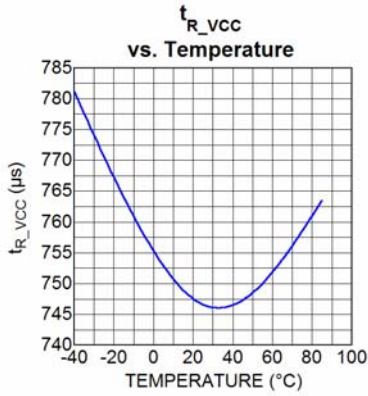
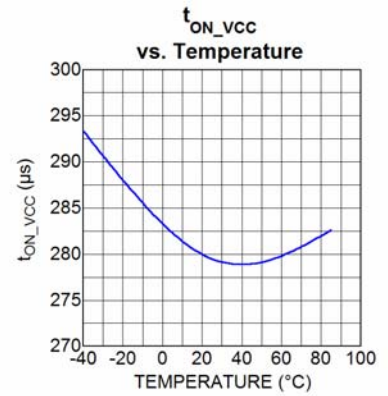
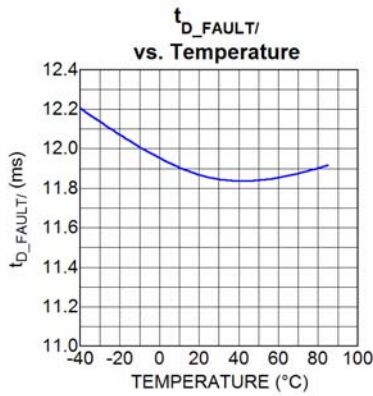
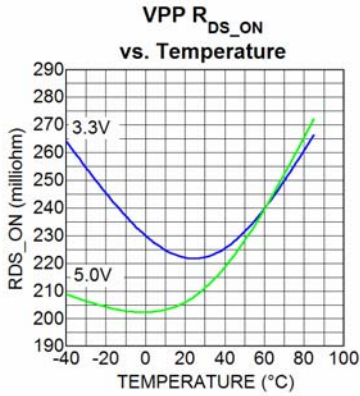
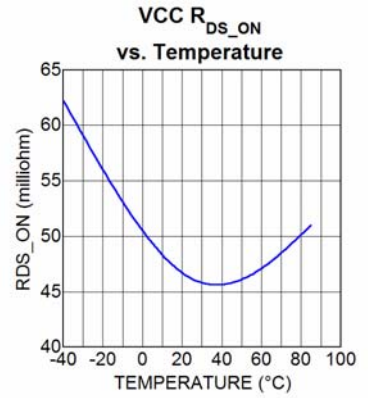
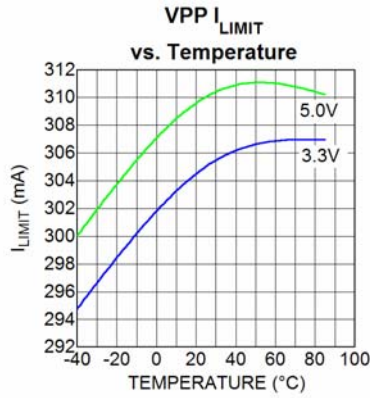
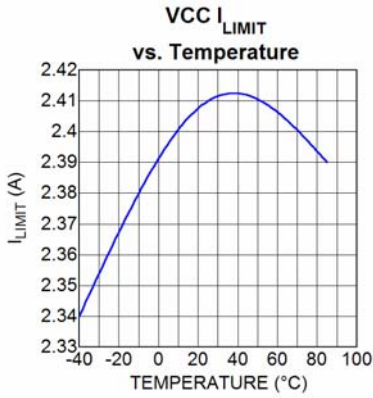
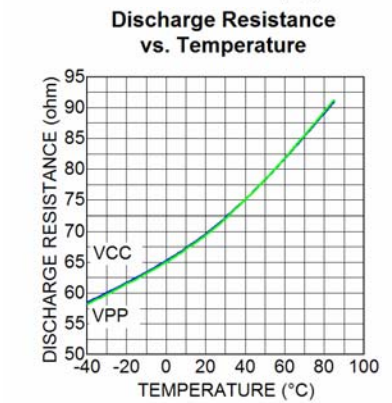
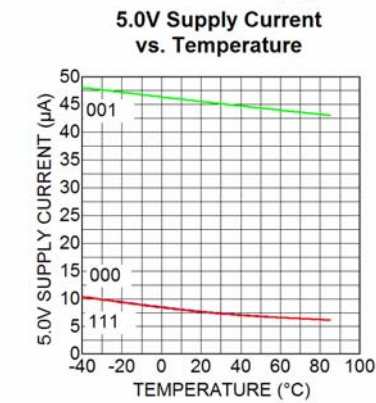
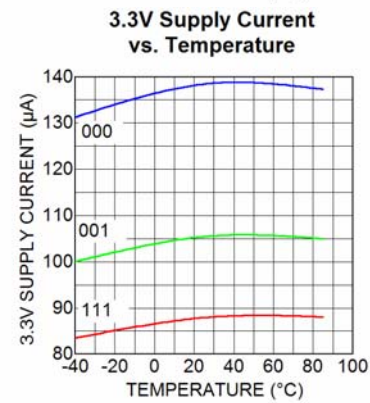
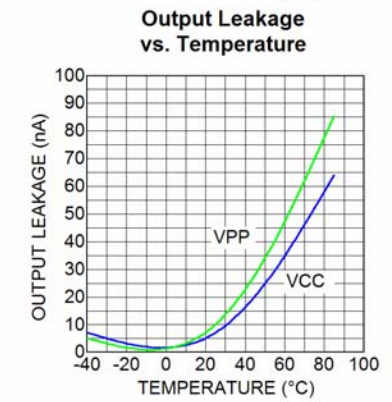
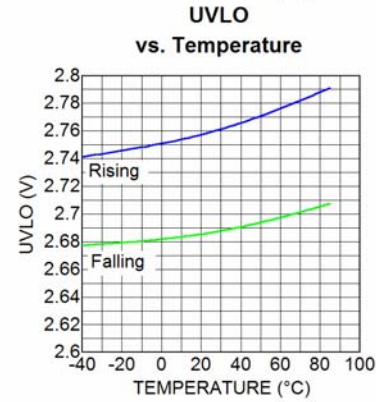
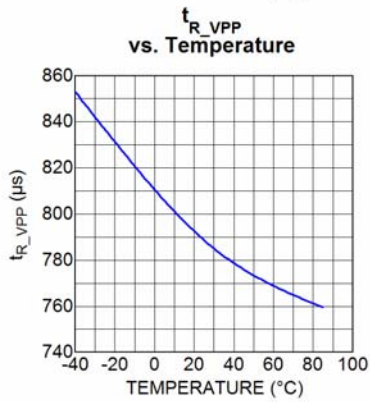
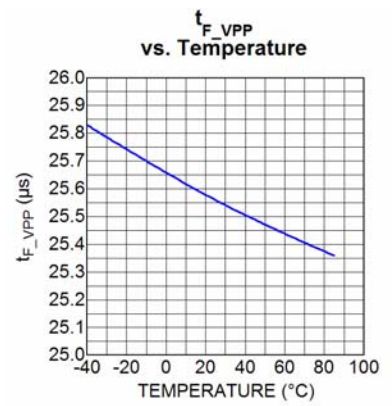
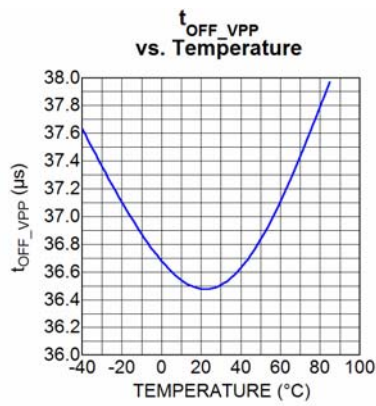
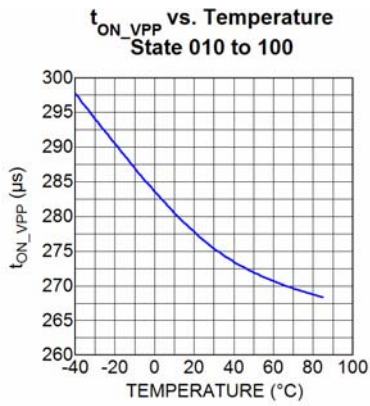

Figure 2. Rise and Fall Time

Typical Characteristics





Functional Characteristics

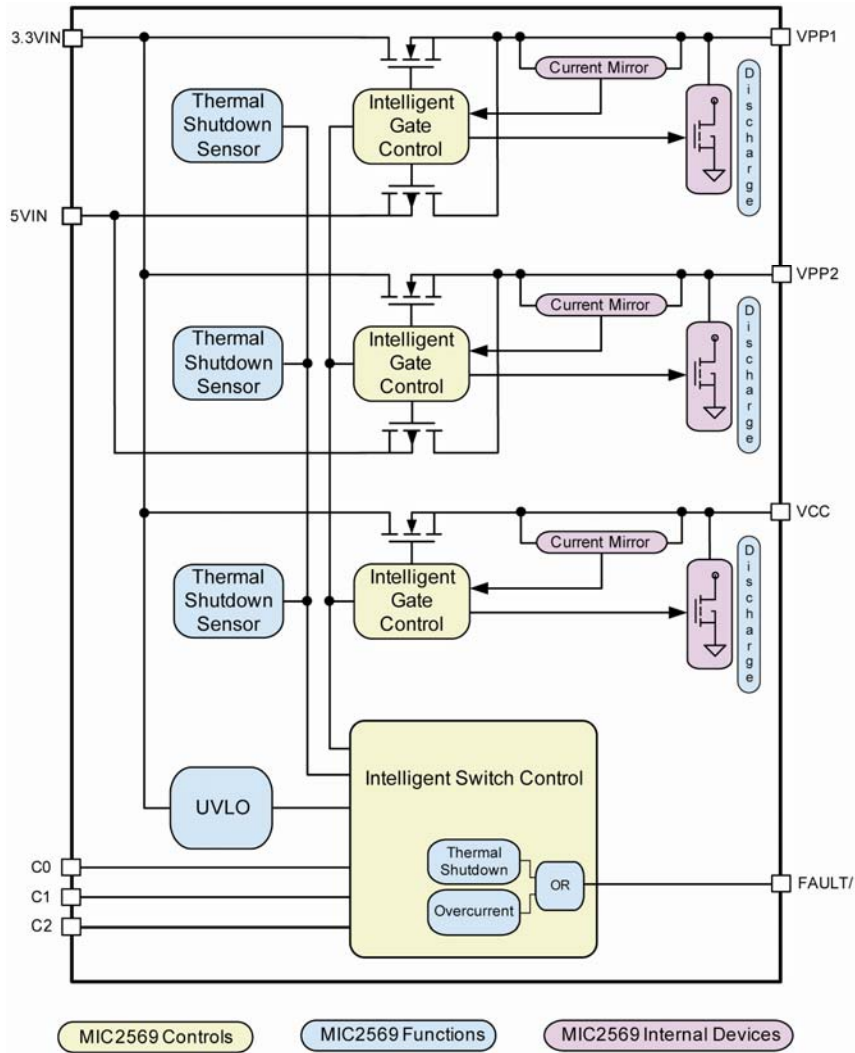

MIC2569 Block Diagram

Functional Description

3.3VIN and 5.0VIN

3.3VIN and 5VIN are the input power supplies for the MIC2569. 3.3VIN powers the MIC2569's internal functions; as well as, VCC, and VPP1 and VPP2. 5VIN provides power to VPP1 and VPP2. Tables 1 and 2 shows the control states which supply is provided to which output

C0, C1, C2 (States Controls)

C0, C1, and C2 control the output conditions for VCC, VPP1 and VPP2. C0, C1, and C2 are inputs to the MIC2569 provided by the host. See Tables 1 and 2 for a complete listing. Also see the Application Information section.

VCC

VCC provides the main 3.3V supply to the CableCARD device. VCC is protected against high current conditions and short circuits. The minimum current limit is set to 1.3A from 3.3VIN. Break-before-make switching prevents crossed connections during state changes. The VCC output depends on the host / card combination. See Tables 1 and 2 for a complete listing. Also see the Application Information section.

VPP1, VPP2 (VPP1/2)

VPP1 and VPP2 provide the 3.3V and 5.0V supplies to the CableCARD device. VPP1 and VPP2 are protected against high current conditions and short circuits. The minimum current limit is set to a minimum of 150mA. **Note:** VPP1 and VPP2 are powered separately with each having a current limit of 150mA Break-before-make switching prevents crossed connections during state changes. The VPP1/2 output depends on the host / card combination. See Tables 1 and 2 for a complete listing. Also see the Application Information section.

Soft-Start

The VCC, VPP1 and VPP2 outputs are all slew rate

controlled insuring a soft-start turn-on characteristic. Soft-starting is in effect anytime a supply ramps from a 0V condition or switches between voltages, as in the case of the VPP outputs.

Thermal Shutdown

Because electrical faults can cause significant heating in power switches, MIC2569 monitors its internal temperature and will shut down should the die temperature reach 140°C. When the die temperature has dropped by about 10 degrees, MIC2569 will reactivate its outputs. If there is still a problem, the effected power switch will again get hot, shutting off all outputs. This power cycling action will continue as long as the fault persists. Once removed, MIC2569 will resume normal operation.

FAULT/

FAULT/ is a LOW true open drain output which signals an over current or over-temp condition. As an open drain device, this output can be wire OR'd with other FAULT/ outputs to a single input pin on the host. For proper operation this output must be pulled-up to the logic supply rail by an external resistor. This resistor can be large in value, but not so large that leakage currents caused by surface contamination can cause a false indication of a fault condition. For this reason it is recommended that the pull-up resistor be 300kΩ or less.

FAULT/ is delayed with respect to an over current condition being detected. This is to prevent brief current spikes from triggering an interrupt to the system host. The delay is on the order of 12ms. Any fault lasting over 8 ms triggers the FAULT/ output. There is no delay for thermal faults. Any over-temp condition is reported immediately.

UVLO (Under Voltage Lockout)

An under-voltage lock out (UVLO) circuit monitors the 3.3VIN rail and keeps MIC2569 disabled until the input voltage reaches the minimum level needed for proper operation. Below this voltage the output switches are OFF and all functionality is disabled.

System State	S-Mode				M-Mode			
	State	VCC	VPP1	VPP2	State	VCC	VPP1	VPP2
Power-up	000	3.3V	3.3V	3.3V	010	Hi-Z	Hi-Z	Hi-Z
No Card	000	3.3V	3.3V	3.3V	010	Hi-Z	Hi-Z	Hi-Z
Card Detect	000	3.3V	3.3V	3.3V	011	Hi-Z	GND	Hi-Z
After ID	000	3.3V	3.3V	3.3V	100	3.3V	GND	5V
CIS request	001	3.3V	5V	5V	—	—	—	—
Card removal	000	3.3V	3.3V	3.3V	111	GND	GND	GND
No Card	000	3.3V	3.3V	3.3V	010	Hi-Z	Hi-Z	Hi-Z

Table 1 Output States for S and M type CableCARD™s

Control State	Control Pins			Outputs		
	C2	C1	C0	VCC	VPP1	VPP2
0	0	0	0	3.3V	3.3V	3.3V
1	0	0	1	3.3V	5V	5V
2	0	1	0	Hi-Z	Hi-Z	Hi-Z
3	0	1	1	Hi-Z	GND	Hi-Z
4	1	0	0	3.3V	GND	5V
5	1	0	1	3.3V	5V	GND
6	1	1	0	3.3V	GND	GND
7	1	1	1	GND	GND	GND

Table 2 Output Control

Application Information

CableCARD™ Operating Modes

The OpenCable system has a host component (S-Host or M-Host) and a card component (S-Card or M-Card). The host / card combination determines which operational mode is used i.e. S-Mode or M-Mode. This in turn determines the appropriate state diagram. Table 3 below shows all of the combinations and operating modes.

	S-Host	M-Host
S-Card	S-Mode	S-Mode or No power
M-Card	S-Mode	M-Mode

Table 3 Operating Mode Combinations

An M-Host has the choice to accept or not accept an S-Card. If the M-Host accepts the S-Card then the M-Host will initiate a change from M-Mode to S-Mode. Otherwise, the M-Host will not power-up the S-Card.

S-Host

After power-up, the S-Host remains in state 0 [000] unless one of two events occurs:

1. CIS Request – The CableCARD™ may request that the Vpp outputs be provided with 5VIN, that is, enter state 1 [001]. It is the S-Host decision whether to provide the Vpp outputs with 5VIN. The S-Host has two possible options.
 - a. If the S-Host refuses to provide 5VIN, then the S-Host does not change to state 1 [001] and will remain in state 0 [000], even upon card removal. See paragraph 2 below.
 - b. If the S-Host grants 5VIN, then S-Host changes to state 1 [001]. The S-Host remains in state 1 [001] without returning. See paragraph 2 below.
2. Card removal – Upon card removal, the S-Host has two possible options:
 - a. The S-Host changes directly to state 0 [000], regardless of the state at card was removed.
 - b. The S-Host has the option to pass through state 6 [110] to remove any excessive voltage or charge on the Vpp outputs. The S-Host then returns to state 0 [000].

Figure 1 shows S-Mode power state diagram.

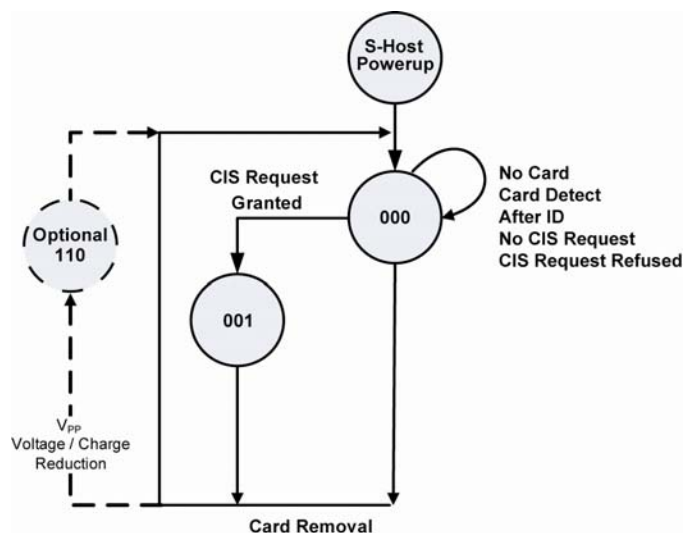

Figure 1 S-Host Power State Diagram

M-Host

1. Power-up - Upon power-up, M-Host two options:
 - a. Move directly the state 2 [010]
 - b. Pass through state 7 [111] to remove any excess voltage or charge, then move to state 2 [010]
2. No Card – M-Host will remain in state 2 [010] until card insertion.
3. Card Detection – If the M-Host detects that the inserted card is an M-card, then the M-Host will change to state 3 [011]. This informs the card that the host is an M-Host.
4. Card ID – The M-Host uses the card identification process to determine what type of card it is and what modes the card can operate in. There are three options:
 - a. If the card is an M-Card, then the M-Host will change to state 4 [100] and remain in state 4 [100] until card removal.
 - b. If the card is an S-Card able to support CH1, then the M-Host will reset the card and power-up in S-Mode. The card will remain in S-Mode until card removal.
 - c. If the card is not an M-Card, or an S-Card not able to support Ch1, then power will not be provided to the card. The card will remain without power and not change state until card removal.

5. Card removal – Upon card removal the M-Host will pass through state 7 [111] to remove any excessive voltage or charge on the Vcc and Vpp outputs. The M-Host then returns to state 2 [010].

Figure 2 below shows M-Mode power state diagram.

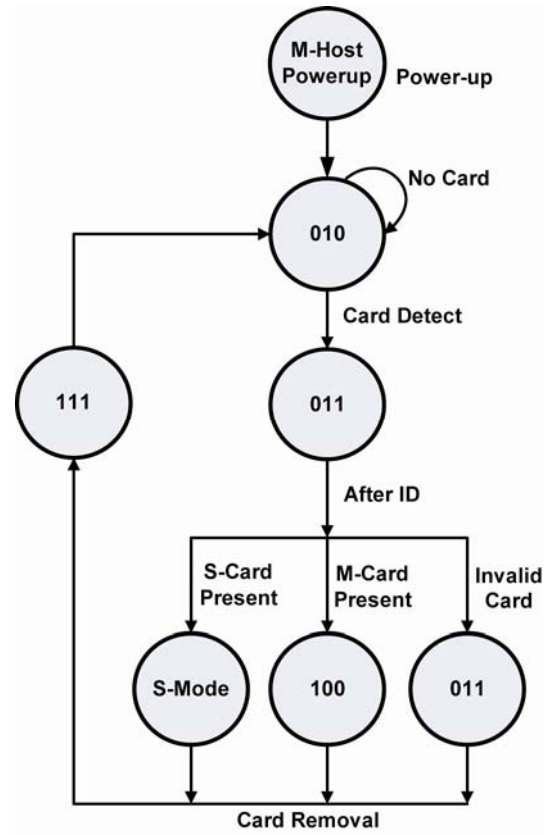
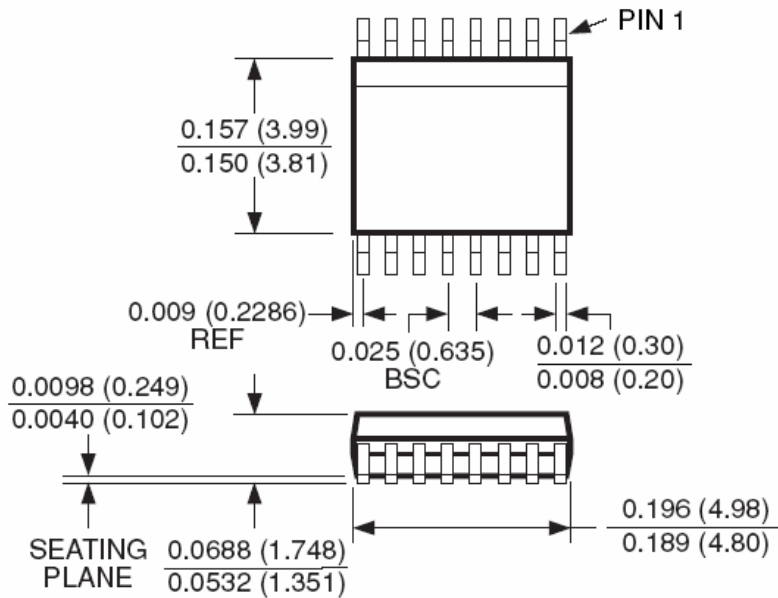
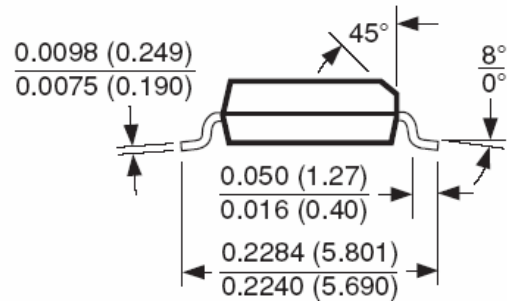

Figure 2 M-Host Power State Diagram

Package Information



DIMENSIONS:
INCHES (MM)



16-Pin QSOP (QS)

MICREL, INC. 2180 FORTUNE DRIVE SAN JOSE, CA 95131 USA
 TEL +1 (408) 944-0800 FAX +1 (408) 474-1000 WEB <http://www.micrel.com>

The information furnished by Micrel in this data sheet is believed to be accurate and reliable. However, no responsibility is assumed by Micrel for its use. Micrel reserves the right to change circuitry and specifications at any time without notification to the customer.

Micrel Products are not designed or authorized for use as components in life support appliances, devices or systems where malfunction of a product can reasonably be expected to result in personal injury. Life support devices or systems are devices or systems that (a) are intended for surgical implant into the body or (b) support or sustain life, and whose failure to perform can be reasonably expected to result in a significant injury to the user. A Purchaser's use or sale of Micrel Products for use in life support appliances, devices or systems is a Purchaser's own risk and Purchaser agrees to fully indemnify Micrel for any damages resulting from such use or sale.

© 2007 Micrel, Incorporated.

Looking for pricing, stock, or lifecycle information?

Click below to explore more details on WIN SOURCE:

 [View MIC2569YQS-TR on WIN SOURCE](#)

 [Microchip Technology](#) Information

Optimize Your Supply Chain with WIN SOURCE Solutions

-  Global Sourcing Solution
-  Obsolete Management
-  Cost Control Management
-  Shortage Management
-  Alternative Solution
-  Excess Inventory Management