



**THE DATASHEET OF  
AD9577BCPZ-R7**



## FEATURES

- Fully integrated dual PLL/VCO cores
- 1 integer-N and 1 fractional-N PLL
- Continuous frequency coverage from 11.2 MHz to 200 MHz
  - Most frequencies from 200 MHz to 637.5 MHz available
- PLL1 phase jitter (12 kHz to 20 MHz): 460 fs rms typical
- PLL2 phase jitter (12 kHz to 20 MHz)
  - Integer-N mode: 470 fs rms typical
  - Fractional-N mode: 660 fs rms typical
- Input crystal or reference clock frequency
- Optional reference frequency divide-by-2
- I<sup>2</sup>C programmable output frequencies
- Up to 4 LVDS/LVPECL or up to 8 LVCMOS output clocks
- 1 CMOS buffered reference clock output
- Spread spectrum: downspread [0, -0.5]%
- 2 pin-controlled frequency maps: margining
- Integrated loop filters
- Space saving, 6 mm × 6 mm, 40-lead LFCSP package
- 1.02 W power dissipation (LVDS operation)
- 1.235 W power dissipation (LVPECL operation)
- 3.3 V operation

## APPLICATIONS

- Low jitter, low phase noise multioutput clock generator for data communications applications including Ethernet, Fibre Channel, SONET, SDH, PCI-e, SATA, PTN, OTN, ADC/DAC, and digital video
- Spread spectrum clocking

## GENERAL DESCRIPTION

The **AD9577** provides a multioutput clock generator function, along with two on-chip phase-locked loop cores, PLL1 and PLL2, optimized for network clocking applications. The PLL designs are based on the Analog Devices, Inc., proven portfolio of high performance, low jitter frequency synthesizers to maximize network performance. The PLLs have I<sup>2</sup>C programmable output frequencies and formats. The fractional-N PLL can support spread spectrum clocking for reduced EMI radiated peak power. Both PLLs can support frequency margining. Other applications with demanding phase noise and jitter requirements can benefit from this part.

The first integer-N PLL section (PLL1) consists of a low noise phase frequency detector (PFD), a precision charge pump (CP), a low phase noise voltage controlled oscillator (VCO), a programmable

## FUNCTIONAL BLOCK DIAGRAM

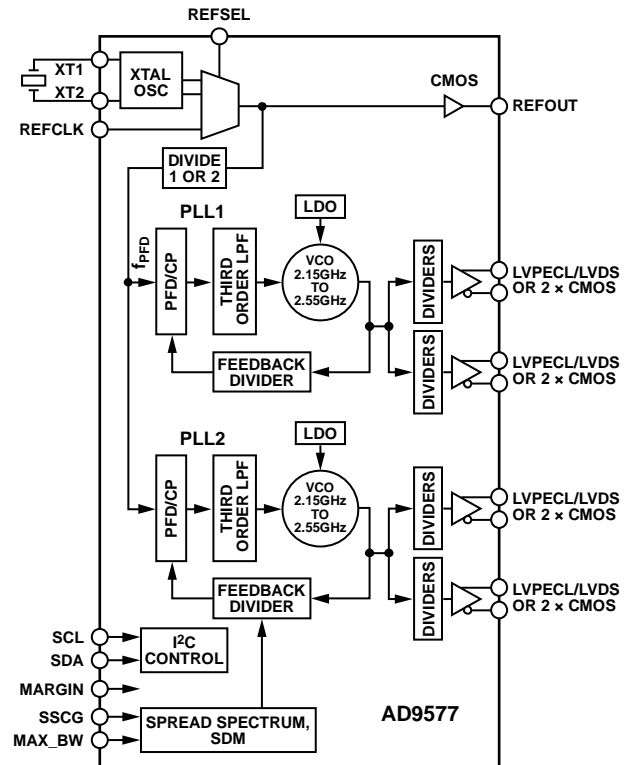

Figure 1.

feedback divider, and two independently programmable output dividers. By connecting an external crystal or applying a reference clock to the REFCLK pin, frequencies of up to 637.5 MHz can be synchronized to the input reference. Each output divider and feedback divider ratio is I<sup>2</sup>C programmed for the required output rates.

A second fractional-N PLL (PLL2) with a programmable modulus allows VCO frequencies that are fractional multiples of the reference frequency to be synthesized. Each output divider and feedback divider ratio can be programmed for the required output rates, up to 637.5 MHz. This fractional-N PLL can also operate in integer-N mode for the lowest jitter.

Up to four differential output clock signals can be configured as either LVPECL or LVDS signaling formats. Alternatively, the outputs can be configured for up to eight CMOS outputs. Combinations of these formats are supported. No external loop filter components are required, thus conserving valuable design time and board space. The **AD9577** is available in a 40-lead, 6 mm × 6 mm LFCSP package and can operate from a single 3.3 V supply. The operating temperature range is -40°C to +85°C.

Rev. A

[Document Feedback](#)

Information furnished by Analog Devices is believed to be accurate and reliable. However, no responsibility is assumed by Analog Devices for its use, nor for any infringements of patents or other rights of third parties that may result from its use. Specifications subject to change without notice. No license is granted by implication or otherwise under any patent or patent rights of Analog Devices. Trademarks and registered trademarks are the property of their respective owners.

One Technology Way, P.O. Box 9106, Norwood, MA 02062-9106, U.S.A.  
 Tel: 781.329.4700 ©2011–2016 Analog Devices, Inc. All rights reserved.  
[Technical Support](#) [www.analog.com](http://www.analog.com)

## TABLE OF CONTENTS

Features .....	1	Example Application .....	28
Applications .....	1	Functional Description .....	29
General Description .....	1	Reference Input and Reference Dividers .....	29
Functional Block Diagram .....	1	Output Channel Dividers .....	30
Revision History .....	2	Outputs .....	30
Specifications .....	3	Reference Output Buffer .....	31
PLL1 Characteristics .....	3	PLL1 Integer-N PLL .....	31
PLL1 Clock Output Jitter .....	5	PLL1 Phase Frequency Detector (PFD) and Charge Pump ..	32
PLL2 Fractional-N Mode Characteristics .....	6	PLL1 VCO .....	32
PLL2 Integer-N Mode Characteristics .....	7	PLL1 Feedback Divider .....	32
PLL2 Clock Output Jitter .....	9	Setting the Output Frequency of PLL1 .....	32
CMOS Reference Clock Output Jitter .....	11	PLL2 Integer/Fractional-N PLL .....	32
Timing Characteristics .....	12	PLL2 Phase Frequency Detector (PFD) and Charge Pump ..	33
Clock Outputs .....	13	PLL2 Loop Bandwidth .....	33
Power .....	14	PLL2 VCO .....	33
Crystal Oscillator .....	15	PLL2 Feedback Divider .....	33
Reference Input .....	15	PLL2 $\Sigma$ - $\Delta$ Modulator .....	33
Control Pins .....	15	Spur Mechanisms .....	33
Absolute Maximum Ratings .....	16	Optimizing PLL Performance .....	34
Thermal Characteristics .....	16	Setting the Output Frequency of PLL2 .....	34
ESD Caution .....	16	Margining .....	35
Pin Configuration and Function Descriptions .....	17	Spread Spectrum Clock Generation (SSCG) .....	35
Typical Performance Characteristics .....	19	I <sup>2</sup> C Interface Timing and Internal Register Description .....	38
REFOUT and PLL1 Phase Noise Performance .....	19	Default Frequency Map and Output Formats .....	40
PLL2 Phase Noise Performance .....	20	I <sup>2</sup> C Interface Operation .....	40
Output Jitter .....	21	Typical Application Circuits .....	42
Typical Output Signal .....	22	Power and Grounding Considerations and Power Supply Rejection .....	43
Typical Spread Spectrum Performance Characteristics .....	24	Outline Dimensions .....	44
Terminology .....	25	Ordering Guide .....	44
Detailed Block Diagram .....	27		

## REVISION HISTORY

### 8/2016—Rev. 0 to Rev. A

Changes to Outputs Section .....

### 10/2011—Revision 0: Initial Version

## SPECIFICATIONS

Typical (typ) is given for  $V_S = 3.3$  V,  $T_A = 25^\circ\text{C}$ , unless otherwise noted. Minimum (min) and maximum (max) values are given over full  $V_S$  (3.0 V to 3.6 V) and  $T_A$  ( $-40^\circ\text{C}$  to  $+85^\circ\text{C}$ ) variation. AC coupling capacitors of 0.1  $\mu\text{F}$  used where appropriate. A Fox Electronics FX532A 25 MHz crystal is used throughout, unless otherwise stated.

### PLL1 CHARACTERISTICS

Table 1.

Parameter	Min	Typ	Max	Unit	Test Conditions/Comments <sup>1</sup>
<b>NOISE CHARACTERISTICS</b>					
Phase Noise (106.25 MHz LVPECL Output)					Na = 102, Vx = 4, Dx = 6, $f_{\text{PFD}} = 25$ MHz
At 1 kHz		-121		dBc/Hz	
At 10 kHz		-127		dBc/Hz	
At 100 kHz		-128		dBc/Hz	
At 1 MHz		-150		dBc/Hz	
At 10 MHz		-156		dBc/Hz	
At 30 MHz		-158		dBc/Hz	
Phase Noise (156.25 MHz LVPECL Output)					Na = 100, Vx = 4, Dx = 4, $f_{\text{PFD}} = 25$ MHz
At 1 kHz		-117		dBc/Hz	
At 10 kHz		-124		dBc/Hz	
At 100 kHz		-124		dBc/Hz	
At 1 MHz		-147		dBc/Hz	
At 10 MHz		-156		dBc/Hz	
At 30 MHz		-156		dBc/Hz	
Phase Noise (625 MHz LVPECL Output)					Na = 100, Vx = 2, Dx = 2, $f_{\text{PFD}} = 25$ MHz
At 1 kHz		-105		dBc/Hz	
At 10 kHz		-112		dBc/Hz	
At 100 kHz		-112		dBc/Hz	
At 1 MHz		-135		dBc/Hz	
At 10 MHz		-150		dBc/Hz	
At 30 MHz		-150		dBc/Hz	
Phase Noise (106.25 MHz LVDS Output)					Na = 102, Vx = 4, Dx = 6, $f_{\text{PFD}} = 25$ MHz
At 1 kHz		-119		dBc/Hz	
At 10 kHz		-127		dBc/Hz	
At 100 kHz		-128		dBc/Hz	
At 1 MHz		-148		dBc/Hz	
At 10 MHz		-156		dBc/Hz	
At 30 MHz		-156		dBc/Hz	
Phase Noise (156.25 MHz LVDS Output)					Na = 100, Vx = 4, Dx = 4, $f_{\text{PFD}} = 25$ MHz
At 1 kHz		-116		dBc/Hz	
At 10 kHz		-124		dBc/Hz	
At 100 kHz		-124		dBc/Hz	
At 1 MHz		-145		dBc/Hz	
At 10 MHz		-155		dBc/Hz	
At 30 MHz		-155		dBc/Hz	
Phase Noise (625 MHz LVDS Output)					Na = 100, Vx = 2, Dx = 2, $f_{\text{PFD}} = 25$ MHz
At 1 kHz		-104		dBc/Hz	
At 10 kHz		-111		dBc/Hz	
At 100 kHz		-112		dBc/Hz	
At 1 MHz		-134		dBc/Hz	
At 10 MHz		-149		dBc/Hz	
At 30 MHz		-149		dBc/Hz	

Parameter	Min	Typ	Max	Unit	Test Conditions/Comments <sup>1</sup>
Phase Noise (106.25 MHz CMOS Output)					Na = 102, Vx = 4, Dx = 6, f <sub>PFD</sub> = 25 MHz
At 1 kHz		-118		dBc/Hz	
At 10 kHz		-127		dBc/Hz	
At 100 kHz		-127		dBc/Hz	
At 1 MHz		-149		dBc/Hz	
At 10 MHz		-156		dBc/Hz	
At 30 MHz		-157		dBc/Hz	
Phase Noise (156.25 MHz CMOS Output)					Na = 100, Vx = 4, Dx = 4, f <sub>PFD</sub> = 25 MHz
At 1 kHz		-115		dBc/Hz	
At 10 kHz		-124		dBc/Hz	
At 100 kHz		-124		dBc/Hz	
At 1 MHz		-146		dBc/Hz	
At 10 MHz		-155		dBc/Hz	
At 30 MHz		-155		dBc/Hz	
Phase Noise (155.52 MHz LVPECL Output)					Na = 112, Vx = 2, Dx = 7, f <sub>PFD</sub> = 19.44 MHz
At 1 kHz		-117		dBc/Hz	
At 10 kHz		-122		dBc/Hz	
At 100 kHz		-123		dBc/Hz	
At 1 MHz		-148		dBc/Hz	
At 10 MHz		-156		dBc/Hz	
At 30 MHz		-156		dBc/Hz	
Phase Noise (622.08 MHz LVPECL Output)					Na = 128, Vx = 2, Dx = 2, f <sub>PFD</sub> = 19.44 MHz
At 1 kHz		-105		dBc/Hz	
At 10 kHz		-110		dBc/Hz	
At 100 kHz		-110		dBc/Hz	
At 1 MHz		-136		dBc/Hz	
At 10 MHz		-150		dBc/Hz	
At 30 MHz		-150		dBc/Hz	
Phase Noise (155.52 MHz LVDS Output)					Na = 112, Vx = 2, Dx = 7, f <sub>PFD</sub> = 19.44 MHz
At 1 kHz		-117		dBc/Hz	
At 10 kHz		-122		dBc/Hz	
At 100 kHz		-123		dBc/Hz	
At 1 MHz		-146		dBc/Hz	
At 10 MHz		-155		dBc/Hz	
At 30 MHz		-155		dBc/Hz	
Phase Noise (622.08 MHz LVDS Output)					Na = 128, Vx = 2, Dx = 2, f <sub>PFD</sub> = 19.44 MHz
At 1 kHz		-105		dBc/Hz	
At 10 kHz		-110		dBc/Hz	
At 100 kHz		-110		dBc/Hz	
At 1 MHz		-134		dBc/Hz	
At 10 MHz		-149		dBc/Hz	
At 30 MHz		-150		dBc/Hz	
Phase Noise (155.52 MHz CMOS Output)					Na = 112, Vx = 2, Dx = 7, f <sub>PFD</sub> = 19.44 MHz
At 1 kHz		-117		dBc/Hz	
At 10 kHz		-122		dBc/Hz	
At 100 kHz		-123		dBc/Hz	
At 1 MHz		-147		dBc/Hz	
At 10 MHz		-155		dBc/Hz	
At 30 MHz		-155		dBc/Hz	

<sup>1</sup> x indicates either 0 or 1 for any given test condition.

## PLL1 CLOCK OUTPUT JITTER

Table 2.

Parameter <sup>1</sup>	Min	Typ	Max	Unit	Test Conditions/Comments <sup>2</sup>
LVPECL INTEGRATED RANDOM PHASE JITTER					25 MHz crystal used
RMS Jitter (625 MHz Output)		460	750	fs rms	12 kHz to 20 MHz, Na = 100, Vx = 2, Dx = 2
		430	650	fs rms	50 kHz to 80 MHz, Na = 100, Vx = 2, Dx = 2
RMS Jitter (156.25 MHz Output)		460	750	fs rms	12 kHz to 20 MHz, Na = 100, Vx = 4, Dx = 4
RMS Jitter (106.25 MHz Output)		460	750	fs rms	12 kHz to 20 MHz, Na = 102, Vx = 4, Dx = 6
LVDS INTEGRATED RANDOM PHASE JITTER					25 MHz crystal used
RMS Jitter (625 MHz Output)		470	820	fs rms	12 kHz to 20 MHz, Na = 100, Vx = 2, Dx = 2
		450	790	fs rms	50 kHz to 80 MHz, Na = 100, Vx = 2, Dx = 2
RMS Jitter (156.25 MHz Output)		470	790	fs rms	12 kHz to 20 MHz, Na = 100, Vx = 4, Dx = 4
RMS Jitter (106.25 MHz Output)		470	790	fs rms	12 kHz to 20 MHz, Na = 102, Vx = 4, Dx = 6
CMOS INTEGRATED RANDOM PHASE JITTER					25 MHz crystal used, 50 Ω load
RMS Jitter (100 MHz Output)		470	920	fs rms	12 kHz to 20 MHz, Na = 96, Vx = 4, Dx = 6
RMS Jitter (33.3 MHz Output)		420	700	fs rms	12 kHz to 5 MHz, Na = 88, Vx = 6, Dx = 11
LVPECL INTEGRATED RANDOM PHASE JITTER					19.44 MHz crystal used
RMS Jitter (622.08 MHz Output)		500	680	fs rms	12 kHz to 20 MHz, Na = 128, Vx = 2, Dx = 2
		460	590	fs rms	50 kHz to 80 MHz, Na = 128, Vx = 2, Dx = 2
RMS Jitter (155.52 MHz Output)		480	680	fs rms	12 kHz to 20 MHz, Na = 112, Vx = 2, Dx = 7
LVDS INTEGRATED RANDOM PHASE JITTER					19.44 MHz crystal used
RMS Jitter (622.08 MHz Output)		520	780	fs rms	12 kHz to 20 MHz, Na = 128, Vx = 2, Dx = 2
		480	710	fs rms	50 kHz to 80 MHz, Na = 128, Vx = 2, Dx = 2
RMS Jitter (155.52 MHz Output)		480	750	fs rms	12 kHz to 20 MHz, Na = 112, Vx = 2, Dx = 7
CMOS INTEGRATED RANDOM PHASE JITTER					19.44 MHz crystal used, 50 Ω load
RMS Jitter (155.52 MHz Output)		470	700	fs rms	12 kHz to 20 MHz, Na = 112, Vx = 2, Dx = 7
RMS Jitter (38.88 MHz Output)		440	650	fs rms	12 kHz to 5 MHz, Na = 112, Vx = 2, Dx = 28
LVPECL PERIOD AND CYCLE-TO-CYCLE JITTER (100 MHz OUTPUT)					25 MHz crystal used, Na = 96, Vx = 4, Dx = 6
Output Peak-to-Peak Period Jitter		13		ps p-p	10,000 cycles, average of 25 measurements
Output RMS Period Jitter		2		ps rms	10,000 cycles, average of 25 measurements
Output Peak-to-Peak, Cycle-to-Cycle Jitter		19		ps p-p	1,000 cycles, average of 25 measurements
Output RMS Cycle-to-Cycle Jitter		3		ps rms	1,000 cycles, average of 25 measurements
LVDS PERIOD AND CYCLE-TO-CYCLE JITTER (100 MHz OUTPUT)					25 MHz crystal used, Na = 96, Vx = 4, Dx = 6
Output Peak-to-Peak Period Jitter		17		ps p-p	10,000 cycles, average of 25 measurements
Output RMS Period Jitter		2		ps rms	10,000 cycles, average of 25 measurements
Output Peak-to-Peak, Cycle-to-Cycle Jitter		25		ps p-p	1,000 cycles, average of 25 measurements
Output RMS Cycle-to-Cycle Jitter		4		ps rms	1,000 cycles, average of 25 measurements
CMOS PERIOD AND CYCLE-TO-CYCLE JITTER (100 MHz OUTPUT)					25 MHz crystal used, 50 Ω load, Na = 96, Vx = 4, Dx = 6
Output Peak-to-Peak Period Jitter		25		ps p-p	10,000 cycles, average of 25 measurements
Output RMS Period Jitter		3		ps rms	10,000 cycles, average of 25 measurements
Output Peak-to-Peak Cycle-to-Cycle Jitter		36		ps p-p	1,000 cycles, average of 25 measurements
Output RMS Cycle-to-Cycle Jitter		6		ps rms	1,000 cycles, average of 25 measurements

<sup>1</sup> All period and cycle-to-cycle jitter measurements are made with a Tektronix DPO70604 oscilloscope.<sup>2</sup> x indicates either 0 or 1 for any given test condition.

## PLL2 FRACTIONAL-N MODE CHARACTERISTICS

Table 3. Bleed = 1

Parameter	Min	Typ	Max	Unit	Test Conditions/Comments <sup>1</sup>
<b>NOISE CHARACTERISTICS</b>					
Phase Noise (155.52 MHz LVPECL Output)					25 MHz crystal used Nb = 87, FRAC = 57, MOD = 625, Vx = 2, Dx = 7
At 1 kHz		-107		dBc/Hz	
At 10 kHz		-115		dBc/Hz	
At 100 kHz		-122		dBc/Hz	
At 1 MHz		-146		dBc/Hz	
At 10 MHz		-153		dBc/Hz	
At 30 MHz		-152		dBc/Hz	
Phase Noise (622.08 MHz LVPECL Output)					Nb = 99, FRAC = 333, MOD = 625, Vx = 2, Dx = 2
At 1 kHz		-95		dBc/Hz	
At 10 kHz		-103		dBc/Hz	
At 100 kHz		-109		dBc/Hz	
At 1 MHz		-133		dBc/Hz	
At 10 MHz		-148		dBc/Hz	
At 30 MHz		-150		dBc/Hz	
Phase Noise (155.52 MHz LVDS Output)					Nb = 87, FRAC = 57, MOD = 625, Vx = 2, Dx = 7
At 1 kHz		-107		dBc/Hz	
At 10 kHz		-114		dBc/Hz	
At 100 kHz		-122		dBc/Hz	
At 1 MHz		-145		dBc/Hz	
At 10 MHz		-154		dBc/Hz	
At 30 MHz		-154		dBc/Hz	
Phase Noise (622.08 MHz LVDS Output)					Nb = 99, FRAC = 333, MOD = 625, Vx = 2, Dx = 2
At 1 kHz		-95		dBc/Hz	
At 10 kHz		-103		dBc/Hz	
At 100 kHz		-109		dBc/Hz	
At 1 MHz		-132		dBc/Hz	
At 10 MHz		-147		dBc/Hz	
At 30 MHz		-149		dBc/Hz	
Phase Noise (155.52 MHz CMOS Output)					Nb = 87, FRAC = 57, MOD = 625, Vx = 2, Dx = 7
At 1 kHz		-107		dBc/Hz	
At 10 kHz		-114		dBc/Hz	
At 100 kHz		-122		dBc/Hz	
At 1 MHz		-146		dBc/Hz	
At 10 MHz		-154		dBc/Hz	
At 30 MHz		-154		dBc/Hz	
<b>SPREAD SPECTRUM</b>					
Modulation Range	+0.1		-0.5	%	Downspread, triangle modulation profile
Modulation Frequency		31.25		kHz	Programmable
Peak Power Reduction		10		dB	First harmonic of 100 MHz output, triangle modulation profile, spectrum analyzer resolution bandwidth = 20 kHz

<sup>1</sup>x indicates either 2 or 3 for any given test condition.

## PLL2 INTEGER-N MODE CHARACTERISTICS

Table 4. Bleed = 0

Parameter	Min	Typ	Max	Unit	Test Conditions/Comments <sup>1</sup>
NOISE CHARACTERISTICS					
Phase Noise (106.25 MHz LVPECL Output)					Nb = 102, Vx = 4, Dx = 6, f <sub>PPD</sub> = 25 MHz
At 1 kHz		-116		dBc/Hz	
At 10 kHz		-123		dBc/Hz	
At 100 kHz		-127		dBc/Hz	
At 1 MHz		-148		dBc/Hz	
At 10 MHz		-156		dBc/Hz	
At 30 MHz		-158		dBc/Hz	
Phase Noise (156.25 MHz LVPECL Output)					Nb = 100, Vx = 4, Dx = 4, f <sub>PPD</sub> = 25 MHz
At 1 kHz		-113		dBc/Hz	
At 10 kHz		-120		dBc/Hz	
At 100 kHz		-124		dBc/Hz	
At 1 MHz		-146		dBc/Hz	
At 10 MHz		-156		dBc/Hz	
At 30 MHz		-156		dBc/Hz	
Phase Noise (625 MHz LVPECL Output)					Nb = 100, Vx = 2, Dx = 2, f <sub>PPD</sub> = 25 MHz
At 1 kHz		-101		dBc/Hz	
At 10 kHz		-108		dBc/Hz	
At 100 kHz		-112		dBc/Hz	
At 1 MHz		-134		dBc/Hz	
At 10 MHz		-149		dBc/Hz	
At 30 MHz		-150		dBc/Hz	
Phase Noise (106.25 MHz LVDS Output)					Nb = 102, Vx = 4, Dx = 6, f <sub>PPD</sub> = 25 MHz
At 1 kHz		-117		dBc/Hz	
At 10 kHz		-123		dBc/Hz	
At 100 kHz		-127		dBc/Hz	
At 1 MHz		-147		dBc/Hz	
At 10 MHz		-156		dBc/Hz	
At 30 MHz		-156		dBc/Hz	
Phase Noise (156.25 MHz LVDS Output)					Nb = 100, Vx = 4, Dx = 4, f <sub>PPD</sub> = 25 MHz
At 1 kHz		-113		dBc/Hz	
At 10 kHz		-120		dBc/Hz	
At 100 kHz		-124		dBc/Hz	
At 1 MHz		-145		dBc/Hz	
At 10 MHz		-155		dBc/Hz	
At 30 MHz		-155		dBc/Hz	
Phase Noise (625 MHz LVDS Output)					Nb = 100, Vx = 2, Dx = 2, f <sub>PPD</sub> = 25 MHz
At 1 kHz		-101		dBc/Hz	
At 10 kHz		-108		dBc/Hz	
At 100 kHz		-112		dBc/Hz	
At 1 MHz		-133		dBc/Hz	
At 10 MHz		-148		dBc/Hz	
At 30 MHz		-149		dBc/Hz	
Phase Noise (106.25 MHz CMOS Output)					Nb = 102, Vx = 4, Dx = 6, f <sub>PPD</sub> = 25 MHz
At 1 kHz		-117		dBc/Hz	
At 10 kHz		-123		dBc/Hz	
At 100 kHz		-127		dBc/Hz	
At 1 MHz		-147		dBc/Hz	
At 10 MHz		-156		dBc/Hz	
At 30 MHz		-157		dBc/Hz	

Parameter	Min	Typ	Max	Unit	Test Conditions/Comments <sup>1</sup>
Phase Noise (156.25 MHz CMOS Output)					Nb = 100, Vx = 4, Dx = 4, f <sub>PFD</sub> = 25 MHz
At 1 kHz		-113		dBc/Hz	
At 10 kHz		-119		dBc/Hz	
At 100 kHz		-123		dBc/Hz	
At 1 MHz		-145		dBc/Hz	
At 10 MHz		-154		dBc/Hz	
At 30 MHz		-155		dBc/Hz	
Phase Noise (155.52 MHz LVPECL Output)					Nb = 112, Vx = 2, Dx = 7, f <sub>PFD</sub> = 19.44 MHz
At 1 kHz		-112		dBc/Hz	
At 10 kHz		-118		dBc/Hz	
At 100 kHz		-126		dBc/Hz	
At 1 MHz		-147		dBc/Hz	
At 10 MHz		-155		dBc/Hz	
At 30 MHz		-156		dBc/Hz	
Phase Noise (622.08 MHz LVPECL Output)					Nb = 128, Vx = 2, Dx = 2, f <sub>PFD</sub> = 19.44 MHz
At 1 kHz		-100		dBc/Hz	
At 10 kHz		-106		dBc/Hz	
At 100 kHz		-112		dBc/Hz	
At 1 MHz		-134		dBc/Hz	
At 10 MHz		-149		dBc/Hz	
At 30 MHz		-150		dBc/Hz	
Phase Noise (155.52 MHz LVDS Output)					Nb = 112, Vx = 2, Dx = 7, f <sub>PFD</sub> = 19.44 MHz
At 1 kHz		-113		dBc/Hz	
At 10 kHz		-118		dBc/Hz	
At 100 kHz		-126		dBc/Hz	
At 1 MHz		-145		dBc/Hz	
At 10 MHz		-154		dBc/Hz	
At 30 MHz		-155		dBc/Hz	
Phase Noise (622.08 MHz LVDS Output)					Nb = 128, Vx = 2, Dx = 2, f <sub>PFD</sub> = 19.44 MHz
At 1 kHz		-101		dBc/Hz	
At 10 kHz		-106		dBc/Hz	
At 100 kHz		-112		dBc/Hz	
At 1 MHz		-133		dBc/Hz	
At 10 MHz		-148		dBc/Hz	
At 30 MHz		-150		dBc/Hz	
Phase Noise (155.52 MHz CMOS Output)					Nb = 112, Vx = 2, Dx = 7, f <sub>PFD</sub> = 19.44 MHz
At 1 kHz		-113		dBc/Hz	
At 10 kHz		-118		dBc/Hz	
At 100 kHz		-126		dBc/Hz	
At 1 MHz		-146		dBc/Hz	
At 10 MHz		-155		dBc/Hz	
At 30 MHz		-155		dBc/Hz	

<sup>1</sup> x indicates either 2 or 3 for any given test condition.

## PLL2 CLOCK OUTPUT JITTER

Table 5. Bleed = 0 for Integer-N Mode, Bleed = 1 for Fractional-N Mode

Parameter <sup>1</sup>	Min	Typ	Max	Unit	Test Conditions/Comments <sup>2</sup>
LVPECL INTEGRATED RANDOM PHASE JITTER RMS Jitter (622.08 MHz Output)	660	1200		fs rms	25 MHz crystal used 12 kHz to 20 MHz, fractional-N operation, Nb = 99, FRAC = 333, MOD = 625, Vx = 2, Dx = 2
	500	900		fs rms	50 kHz to 80 MHz, fractional-N operation, Nb = 99, FRAC = 333, MOD = 625, Vx = 2, Dx = 2
	470	800		fs rms	12 kHz to 20 MHz, integer-N operation, Nb = 100, Vx = 2, Dx = 2
	380	650		fs rms	50 kHz to 80 MHz, integer-N operation, Nb = 100, Vx = 2, Dx = 2
	630	1100		fs rms	12 kHz to 20 MHz, fractional-N operation, Nb = 87, FRAC = 57, MOD = 625, Vx = 2, Dx = 7
RMS Jitter (625 MHz Output)	470	800		fs rms	12 kHz to 20 MHz, integer-N operation, Nb = 100, Vx = 4, Dx = 4
RMS Jitter (155.52 MHz Output)	630	1100		fs rms	12 kHz to 20 MHz, fractional-N operation, Nb = 87, FRAC = 57, MOD = 625, Vx = 2, Dx = 7
RMS Jitter (156.25 MHz Output)	470	800		fs rms	12 kHz to 20 MHz, integer-N operation, Nb = 100, Vx = 4, Dx = 4
LVDS INTEGRATED RANDOM PHASE JITTER RMS Jitter (622.08 MHz Output)	660	1200		fs rms	25 MHz crystal used 12kHz to 20 MHz, fractional-N operation, Nb = 99, FRAC = 333, MOD = 625, Vx = 2, Dx = 2
	510	900		fs rms	50 kHz to 80 MHz, fractional-N operation, Nb = 99, FRAC = 333, MOD = 625, Vx = 2, Dx = 2
	470	820		fs rms	12 kHz to 20 MHz, integer-N operation, Nb = 100, Vx = 2, Dx = 2
	380	650		fs rms	50 kHz to 80 MHz, integer-N operation, Nb = 100, Vx = 2, Dx = 2
	620	1100		fs rms	12 kHz to 20 MHz, fractional-N operation, Nb = 87, FRAC = 57, MOD = 625, Vx = 2, Dx = 7
RMS Jitter (625 MHz Output)	470	820		fs rms	12 kHz to 20 MHz, integer-N operation, Nb = 100, Vx = 2, Dx = 2
RMS Jitter (155.52 MHz Output)	620	1100		fs rms	12 kHz to 20 MHz, fractional-N operation, Nb = 87, FRAC = 57, MOD = 625, Vx = 2, Dx = 7
RMS Jitter (156.25 MHz Output)	480	800		fs rms	12 kHz to 20 MHz, integer-N operation, Nb = 100, Vx = 4, Dx = 4
CMOS INTEGRATED RANDOM PHASE JITTER RMS Jitter (155.52 MHz Output)	630	1100		fs rms	25 MHz crystal used, 50 Ω load 12 kHz to 20 MHz, fractional-N operation, Nb = 87, FRAC = 57, MOD = 625, Vx = 2, Dx = 7
	490	800		fs rms	12 kHz to 20 MHz, integer-N operation, Nb = 96, Vx = 4, Dx = 6
	450	700		fs rms	12 kHz to 5 MHz, integer-N operation, Nb = 88, Vx = 6, Dx = 11
LVPECL INTEGRATED RANDOM PHASE JITTER RMS Jitter (622.08 MHz Output)	510	800		fs rms	19.44 MHz crystal used 12 kHz to 20 MHz, integer-N operation, Nb = 128, Vx = 2, Dx = 2
	380	650		fs rms	50 kHz to 80 MHz, integer-N operation, Nb = 128, Vx = 2, Dx = 2
	470	800		fs rms	12 kHz to 20 MHz, integer-N operation, Nb = 112, Vx = 2, Dx = 7
LVDS INTEGRATED RANDOM PHASE JITTER RMS Jitter (622.08 MHz Output)	530	900		fs rms	19.44 MHz crystal used 12 kHz to 20 MHz, integer-N operation, Nb = 128, Vx = 2, Dx = 2
	390	700		fs rms	50 kHz to 80 MHz, integer-N operation, Nb = 128, Vx = 2, Dx = 2
	480	750		fs rms	12 kHz to 20 MHz, integer-N operation, Nb = 112, Vx = 2, Dx = 7
RMS Jitter (155.52 MHz Output)	480	750		fs rms	12 kHz to 20 MHz, integer-N operation, Nb = 112, Vx = 2, Dx = 7

Parameter <sup>1</sup>	Min	Typ	Max	Unit	Test Conditions/Comments <sup>2</sup>
CMOS INTEGRATED RANDOM PHASE JITTER RMS Jitter (155.52 MHz Output)		470	700	fs rms	19.44 MHz crystal used, 50 Ω load 12 kHz to 20 MHz, integer-N operation, Nb = 112, Vx = 2, Dx = 7
RMS Jitter (38.88 MHz Output)		430	650	fs rms	12 kHz to 5 MHz, integer-N operation, Nb = 112, Vx = 2, Dx = 28
LVPECL PERIOD AND CYCLE-TO-CYCLE JITTER (100 MHz OUTPUT)					25 MHz crystal used, integer-N operation, Nb = 96, Vx = 4, Dx = 6
Output Peak-to-Peak Period Jitter		13		ps p-p	10,000 cycles, average of 25 measurements
Output RMS Period Jitter		2		ps rms	10,000 cycles, average of 25 measurements
Output Peak-to-Peak, Cycle-to-Cycle Jitter		19		ps p-p	1,000 cycles, average of 25 measurements
Output RMS Cycle-to-Cycle Jitter		3		ps rms	1,000 cycles, average of 25 measurements
LVDS PERIOD AND CYCLE-TO-CYCLE JITTER (100 MHz OUTPUT)					25 MHz crystal used, integer-N operation, Nb = 96, Vx = 4, Dx = 6
Output Peak-to-Peak Period Jitter		17		ps p-p	10,000 cycles, average of 25 measurements
Output RMS Period Jitter		2		ps rms	10,000 cycles, average of 25 measurements
Output Peak-to-Peak, Cycle-to-Cycle Jitter		26		ps p-p	1,000 cycles, average of 25 measurements
Output RMS Cycle-to-Cycle Jitter		4		ps rms	1,000 cycles, average of 25 measurements
CMOS PERIOD AND CYCLE-TO-CYCLE JITTER (100 MHz OUTPUT)					25 MHz crystal used, 50 Ω load, integer-N operation, Nb = 96, Vx = 4, Dx = 6
Output Peak-to-Peak Period Jitter		25		ps p-p	10,000 cycles, average of 25 measurements
Output RMS Period Jitter		3		ps rms	10,000 cycles, average of 25 measurements
Output Peak-to-Peak, Cycle-to-Cycle		36		ps p-p	1,000 cycles, average of 25 measurements
Output RMS Cycle-to-Cycle Jitter		6		ps rms	1,000 cycles, average of 25 measurements
LVPECL PERIOD AND CYCLE-TO-CYCLE JITTER (100 MHz OUTPUT)					25 MHz crystal used, SSCG on, Nb = 100, FRAC = 0, MOD = 1000, Vx = 5, Dx = 5, CkDiv = 7, NumSteps = 59, FracStep = -8, f <sub>OUT</sub> = 100 MHz with -0.5% downspread at 30.2 kHz
Output Peak-to-Peak Period Jitter		60		ps p-p	10,000 cycles, average of 25 measurements
Output RMS Period Jitter		15		ps rms	10,000 cycles, average of 25 measurements
Output Peak-to-Peak, Cycle-to-Cycle Jitter		20		ps p-p	1,000 cycles, average of 25 measurements
Output RMS Cycle-to-Cycle Jitter		3		ps rms	1,000 cycles, average of 25 measurements
LVDS PERIOD AND CYCLE-TO-CYCLE JITTER (100 MHz OUTPUT)					25 MHz crystal used, SSCG on, Nb = 100, FRAC = 0, MOD = 1000, Vx = 5, Dx = 5, CkDiv = 7, NumSteps = 59, FracStep = -8, f <sub>OUT</sub> = 100 MHz with -0.5% downspread at 30.2 kHz
Output Peak-to-Peak Period Jitter		63		ps p-p	10,000 cycles, average of 25 measurements
Output RMS Period Jitter		15		ps rms	10,000 cycles, average of 25 measurements
Output Peak-to-Peak, Cycle-to-Cycle Jitter		25		ps p-p	1,000 cycles, average of 25 measurements
Output RMS Cycle-to-Cycle Jitter		4		ps rms	1,000 cycles, average of 25 measurements
CMOS PERIOD AND CYCLE-TO-CYCLE JITTER (100 MHz OUTPUT)					25 MHz crystal used, SSCG on, 50 Ω load, Nb = 100, FRAC = 0, MOD = 1000, Vx = 5, Dx = 5, CkDiv = 7, NumSteps = 59, FracStep = -8, f <sub>OUT</sub> = 100 MHz with -0.5% downspread at 30.2 kHz
Output Peak-to-Peak Period Jitter		70		ps p-p	10,000 cycles, average of 25 measurements
Output RMS Period Jitter		15		ps rms	10,000 cycles, average of 25 measurements
Output Peak-to-Peak, Cycle-to-Cycle Jitter		36		ps p-p	1,000 cycles, average of 25 measurements
Output RMS Cycle-to-Cycle Jitter		6		ps rms	1,000 cycles, average of 25 measurements

Parameter <sup>1</sup>	Min	Typ	Max	Unit	Test Conditions/Comments <sup>2</sup>
LVPECL PERIOD AND CYCLE-TO-CYCLE JITTER (100.12 MHz OUTPUT)					
Output Peak-to-Peak Period Jitter		13		ps p-p	25 MHz crystal used, fractional-N operation, Nb = 100, FRAC = 15, MOD = 125, Vx = 5, Dx = 5 10,000 cycles, average of 25 measurements
Output RMS Period Jitter		2		ps rms	10,000 cycles, average of 25 measurements
Output Peak-to-Peak, Cycle-to-Cycle Jitter		20		ps p-p	1,000 cycles, average of 25 measurements
Output RMS Cycle-to-Cycle Jitter		3		ps rms	1,000 cycles, average of 25 measurements
LVDS PERIOD AND CYCLE-TO-CYCLE JITTER (100.12 MHz OUTPUT)					
Output Peak-to-Peak Period Jitter		17		ps p-p	25 MHz crystal used, fractional-N operation, Nb = 100, FRAC = 15, MOD = 125, Vx = 5, Dx = 5 10,000 cycles, average of 25 measurements
Output RMS Period Jitter		2		ps rms	10,000 cycles, average of 25 measurements
Output Peak-to-Peak, Cycle-to-Cycle Jitter		26		ps p-p	1,000 cycles, average of 25 measurements
Output RMS Cycle-to-Cycle Jitter		4		ps rms	1,000 cycles, average of 25 measurements
CMOS PERIOD AND CYCLE-TO-CYCLE JITTER (100.12 MHz OUTPUT)					
Output Peak-to-Peak Period Jitter		25		ps p-p	25 MHz crystal used, 50 Ω load, fractional-N operation, Nb = 100, FRAC = 15, MOD = 125, Vx = 5, Dx = 5 10,000 cycles, average of 25 measurements
Output RMS Period Jitter		3		ps rms	10,000 cycles, average of 25 measurements
Output Peak-to-Peak, Cycle-to-Cycle Jitter		36		ps p-p	1,000 cycles, average of 25 measurements
Output RMS Cycle-to-Cycle Jitter		6		ps rms	1,000 cycles, average of 25 measurements

<sup>1</sup> All period and cycle-to-cycle jitter measurements are made with a Tektronix DPO70604 oscilloscope.

<sup>2</sup> x indicates either 2 or 3 for any given test condition.

## CMOS REFERENCE CLOCK OUTPUT JITTER

Table 6.

Parameter	Min	Typ	Max	Unit	Test Conditions/Comments
JITTER INTEGRATION BANDWIDTH					
12 kHz to 5 MHz		680	1000	fs rms	Jitter measurement at 25 MHz is equipment limited 25 MHz
200 kHz to 5 MHz		670	950	fs rms	

**TIMING CHARACTERISTICS**

Table 7.

Parameter	Min	Typ	Max	Unit	Test Conditions/Comments
LVPECL (see Figure 2)					Termination = 200 Ω to 0 V, ac-coupled to 50 Ω oscilloscope; C <sub>LOAD</sub> = 5 pF
Output Rise Time, t <sub>RP</sub>	170	225	300	ps	20% to 80%, measured differentially
Output Fall Time, t <sub>FP</sub>	170	230	310	ps	80% to 20%, measured differentially
Skew		20		ps	Between the outputs of the same PLL at the same frequency. SyncCh01/SyncCh23 set to 1
LVDS (see Figure 3)					Termination = 100 Ω differential; C <sub>LOAD</sub> = 5 pF
Output Rise Time, t <sub>RL</sub>	180	250	340	ps	20% to 80%, measured differentially
Output Fall Time, t <sub>FL</sub>	180	260	330	ps	80% to 20%, measured differentially
Skew		20		ps	Between the outputs of the same PLL at the same frequency; SyncCh01/SyncCh23 set to 1
CMOS (see Figure 4)					Termination is high impedance active probe, total C <sub>LOAD</sub> = 5 pF, R <sub>LOAD</sub> = 20 kΩ, 20% to 80%
Output Rise Time, t <sub>RC</sub>	250	680	950	ps	Termination is high impedance active probe, total C <sub>LOAD</sub> = 5 pF, R <sub>LOAD</sub> = 20 kΩ, 80% to 20%
Output Fall Time, t <sub>FC</sub>	350	700	1000	ps	Termination is high impedance active probe, total C <sub>LOAD</sub> = 5 pF, R <sub>LOAD</sub> = 20 kΩ, 80% to 20%
Skew		20		ps	Between the outputs of the same PLL at the same frequency; SyncCh01/SyncCh23 set to 1

**Timing Diagrams**

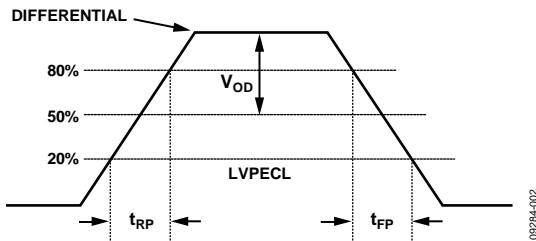

Figure 2. LVPECL Timing, Differential

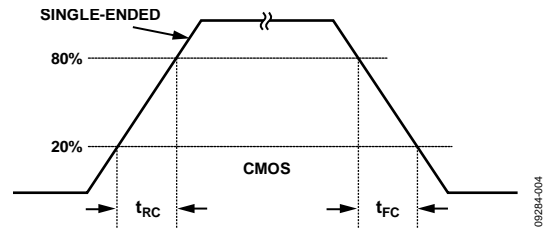

Figure 4. CMOS Timing, Single-Ended, 5 pF Load

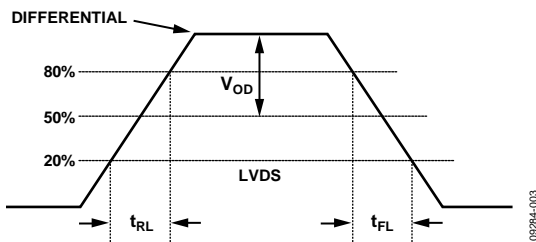

Figure 3. LVDS Timing, Differential

**CLOCK OUTPUTS**AC coupling capacitors of 0.1  $\mu$ F used where appropriate.**Table 8.**

Parameter	Min	Typ	Max	Unit	Test Conditions/Comments
<b>LVPECL CLOCK OUTPUTS</b>					
Output Frequency			637.5	MHz	Load is 200 $\Omega$ to GND at output pins, then ac-coupled to 50 $\Omega$ terminated measurement equipment.
Output Voltage Swing, $V_{OD}$	610	740	950	mV	Load is 200 $\Omega$ to GND at output pins, then ac-coupled to 50 $\Omega$ terminated measurement equipment. For differential amplitude, see Figure 2.
Duty Cycle	45		55	%	Load is 200 $\Omega$ to GND at output pins, then ac-coupled to 50 $\Omega$ terminated measurement equipment.
Output High Voltage, $V_{OH}$	$V_S - 1.24$	$V_S - 0.94$	$V_S - 0.83$	V	Load is 127 $\Omega$ /83 $\Omega$ potential divider across supply dc-coupled into 1 M $\Omega$ terminated measurement equipment, outputs static.
Output Low Voltage, $V_{OL}$	$V_S - 2.07$	$V_S - 1.75$	$V_S - 1.62$	V	Load is 127 $\Omega$ /83 $\Omega$ potential divider across supply dc-coupled into 1 M $\Omega$ terminated measurement equipment, outputs static.
<b>LVDS CLOCK OUTPUTS</b>					
Output Frequency			637.5	MHz	Load is ac-coupled to measurement equipment that provides 100 $\Omega$ differential input termination.
Differential Output Voltage, $V_{OD}$	250	350	475	mV	Load is ac-coupled to measurement equipment that provides 100 $\Omega$ differential input termination. For differential amplitude, see Figure 3.
Delta $V_{OD}$			25	mV	Load is ac-coupled to measurement equipment that provides 100 $\Omega$ differential input termination.
Duty Cycle	45		55	%	Load is ac-coupled to measurement equipment that provides 100 $\Omega$ differential input termination.
Output Offset Voltage, $V_{OS}$	1.125	1.25	1.375	V	Load is dc-coupled to a 100 $\Omega$ differential resistor into 1 M $\Omega$ terminated measurement equipment, outputs static.
Delta $V_{OS}$			25	mV	Load is dc-coupled to a 100 $\Omega$ differential resistor into 1 M $\Omega$ terminated measurement equipment, outputs static.
Short-Circuit Current, $I_{SA}$ , $I_{SB}$		13	24	mA	Load is dc-coupled to a 100 $\Omega$ differential resistor into 1 M $\Omega$ terminated measurement equipment, output shorted to GND.
<b>CMOS CLOCK OUTPUTS</b>					
Output Frequency			200	MHz	
Output High Voltage, $V_{OH}$	$V_S - 0.15$			V	Sourcing 1.0 mA current, outputs static.
Output Low Voltage, $V_{OL}$			0.1	V	Sinking 1.0 mA current, outputs static.
Duty Cycle	45		55	%	Termination is high impedance active probe; total $C_{LOAD} = 5$ pF, $R_{LOAD} = 20$ k $\Omega$ .

## POWER

Table 9.

Parameter	Min	Typ	Max	Unit	Test Conditions/Comments
POWER SUPPLY	3.0	3.3	3.6	V	
LVPECL POWER DISSIPATION		1235	1490	mW	Typical part configuration, both PLLs enabled for integer-N operation, $f_{OUT0} = 156.25$ MHz, $f_{OUT1} = 125$ MHz, $f_{OUT2} = 100$ MHz, $f_{OUT3} = 33.33$ MHz, $N_a = 100$ , $V_0 = 4$ , $D_0 = 4$ , $V_1 = 4$ , $D_1 = 5$ , $N_b = 96$ , $V_2 = 4$ , $D_2 = 6$ , $V_3 = 4$ , $D_3 = 18$ , 25 MHz crystal used, load is 200 $\Omega$ to GND at output pins, then ac-coupled to 50 $\Omega$ terminated measurement equipment
		1270	1530	mW	Worst-case part configuration, PLL2 in fractional-N mode, with SSCG enabled, $f_{OUT0} = 379.16$ MHz, $f_{OUT1} = 379.16$ MHz, $f_{OUT2} = 359.33$ MHz, $f_{OUT3} = 359.33$ MHz, $N_a = 91$ , $V_0 = 3$ , $D_0 = 2$ , $V_1 = 3$ , $D_1 = 2$ , $N_b = 86$ , $V_2 = 3$ , $D_2 = 2$ , $V_3 = 3$ , $D_3 = 2$ , $FRAC = 300$ , $MOD = 1250$ , $CkDiv = 5$ , $NumSteps = 77$ , $FracStep = -7$ , $-0.5\%$ downspread at 32 kHz, 25 MHz crystal used, load is 200 $\Omega$ to GND at output pins, then ac-coupled to 50 $\Omega$ terminated measurement equipment
LVDS POWER DISSIPATION		1020	1200	mW	Typical part configuration, both PLLs enabled for integer-N operation, $f_{OUT0} = 156.25$ MHz, $f_{OUT1} = 125$ MHz, $f_{OUT2} = 100$ MHz, $f_{OUT3} = 33.33$ MHz, $N_a = 100$ , $V_0 = 4$ , $D_0 = 4$ , $V_1 = 4$ , $D_1 = 5$ , $N_b = 96$ , $V_2 = 4$ , $D_2 = 6$ , $V_3 = 4$ , $D_3 = 18$ , 25 MHz crystal used, load ac-coupled to measurement equipment that provides 100 $\Omega$ differential input termination
		1085	1290	mW	Worst-case part configuration, PLL2 in fractional-N mode, with SSCG enabled, $f_{OUT0} = 379.16$ MHz, $f_{OUT1} = 379.16$ MHz, $f_{OUT2} = 359.33$ MHz, $f_{OUT3} = 359.33$ MHz, $N_a = 91$ , $V_0 = 3$ , $D_0 = 2$ , $V_1 = 3$ , $D_1 = 2$ , $N_b = 86$ , $V_2 = 3$ , $D_2 = 2$ , $V_3 = 3$ , $D_3 = 2$ , $FRAC = 300$ , $MOD = 1250$ , $CkDiv = 5$ , $NumSteps = 77$ , $FracStep = -7$ , $-0.5\%$ downspread at 32 kHz, 25 MHz crystal used, load ac-coupled to measurement equipment that provides 100 $\Omega$ differential input termination
CMOS POWER DISSIPATION		1065	1380	mW	Typical part configuration, both PLLs enabled for integer-N operation, $f_{OUT0} = 156.25$ MHz, $f_{OUT1} = 125$ MHz, $f_{OUT2} = 100$ MHz, $f_{OUT3} = 33.33$ MHz, $N_a = 100$ , $V_0 = 4$ , $D_0 = 4$ , $V_1 = 4$ , $D_1 = 5$ , $N_b = 96$ , $V_2 = 4$ , $D_2 = 6$ , $V_3 = 4$ , $D_3 = 18$ , 25 MHz crystal used, eight single-ended outputs active, $C_{LOAD} = 5$ pF
		1190	1510	mW	Worst-case part configuration, PLL2 in fractional-N mode, with SSCG enabled, $f_{OUT0} = 189.58$ MHz, $f_{OUT1} = 189.58$ MHz, $f_{OUT2} = 179.66$ MHz, $f_{OUT3} = 179.66$ MHz, $N_a = 91$ , $V_0 = 3$ , $D_0 = 4$ , $V_1 = 3$ , $D_1 = 4$ , $N_b = 86$ , $V_2 = 3$ , $D_2 = 4$ , $V_3 = 3$ , $D_3 = 4$ , $FRAC = 300$ , $MOD = 1250$ , $CkDiv = 5$ , $NumSteps = 77$ , $FracStep = -7$ , $-0.5\%$ downspread at 32 kHz, 25 MHz crystal used, eight single-ended outputs active, $C_{LOAD} = 5$ pF
POWER CHANGES					Reduction in power due to turning off a channel of one VCO divider, one output divider, and one output buffer; data for Channel 1, with typical part configuration, both PLLs enabled for integer-N operation, $f_{OUT0} = 156.25$ MHz, $f_{OUT1} = 125$ MHz, $f_{OUT2} = 100$ MHz, $f_{OUT3} = 33.33$ MHz, $N_a = 100$ , $V_0 = 4$ , $D_0 = 4$ , $V_1 = 4$ , $D_1 = 5$ , $N_b = 96$ , $V_2 = 4$ , $D_2 = 6$ , $V_3 = 4$ , $D_3 = 18$ , 25 MHz crystal used
Power-Down 1 LVPECL Channel	160	205		mW	Load 200 $\Omega$ to GND at output pins, and ac-coupled to 50 $\Omega$ terminated measurement equipment
Power-Down 1 LVDS Channel	105	155		mW	Load ac-coupled to measurement equipment that provides 100 $\Omega$ differential input termination
Power-Down 1 CMOS Channel	130	170		mW	Eight single-ended outputs active, $C_{LOAD} = 5$ pF

**CRYSTAL OSCILLATOR**

Table 10.

Parameter	Min	Typ	Max	Unit	Test Conditions/Comments
CRYSTAL SPECIFICATION					Fundamental mode
Frequency	19.44	25	27	MHz	Reference divider, R = 1, only
ESR			50	$\Omega$	
Load Capacitance		14		pF	
Phase Noise		-135		dBc/Hz	1 kHz offset
Stability	-50		+50	ppm	

**REFERENCE INPUT**

Table 11.

Parameter	Min	Typ	Max	Unit	Test Conditions/Comments
CLOCK INPUT (REFCLK)					
Input Frequency	19.44	25	27	MHz	Reference divider, R = 1
	38.88	50	54	MHz	Reference divider, R = 2
Input High Voltage	2.0			V	
Input Low Voltage			0.8	V	
Input Current	-1.0		+1.0	$\mu$ A	
Input Capacitance		2		pF	

**CONTROL PINS**

Table 12.

Parameter	Min	Typ	Max	Unit	Test Conditions/Comments
INPUT CHARACTERISTICS					
SSCG, MAX_BW, and MARGIN					SSCG, MAX_BW, and MARGIN have a 30 k $\Omega$ internal pull-down resistor
Logic 1 Voltage	2.0			V	
Logic 0 Voltage			0.8	V	
Logic 1 Current			240	$\mu$ A	
Logic 0 Current			40	$\mu$ A	
REFSEL					REFSEL has a 30 k $\Omega$ internal pull-up resistor
Logic 1 Voltage	2.0			V	
Logic 0 Voltage			0.8	V	
Logic 1 Current			70	$\mu$ A	
Logic 0 Current			240	$\mu$ A	
I <sup>2</sup> C DC CHARACTERISTICS					
Input Voltage High	0.7 V <sub>CC</sub>			V	LVC MOS; the SCL and SDA pins only, see Figure 48
Input Voltage Low			0.3 V <sub>CC</sub>	V	
Input Current	-10		+10	$\mu$ A	V <sub>IN</sub> = 0.1 V <sub>CC</sub> or V <sub>IN</sub> = 0.9 V <sub>CC</sub>
Output Low Voltage			0.4	V	V <sub>OL</sub> with a load current of I <sub>OL</sub> = 3.0 mA
I <sup>2</sup> C TIMING CHARACTERISTICS					
SCL Clock Frequency			400	kHz	LVC MOS; the SCL and SDA pins only, see Figure 48
SCL Pulse Width High					
High, t <sub>HIGH</sub>	600			ns	
Low, t <sub>LOW</sub>	1300			ns	
Start Condition					
Hold Time, t <sub>HD; STA</sub>	600			ns	
Setup Time, t <sub>SU; STA</sub>	600			ns	
Data					
Setup Time, t <sub>SU; DAT</sub>	100			ns	
Hold Time, t <sub>HD; DAT</sub>	300			ns	
Stop Condition Setup Time, t <sub>SU; STO</sub>	600			ns	
Bus Free Time Between a Stop and a Start, t <sub>BUF</sub>	1300			ns	

## ABSOLUTE MAXIMUM RATINGS

Table 13.

Parameter	Rating
V <sub>S</sub> to GND	−0.3 V to +3.6 V
REFCLK to GND	−0.3 V to V <sub>S</sub> + 0.3 V
LDO to GND	−0.3 V to V <sub>S</sub> + 0.3 V
XT1, XT2 to GND	−0.3 V to V <sub>S</sub> + 0.3 V
SSCG, MAX_BW, MARGIN, SCL, SDA, REFSEL to GND	−0.3 V to V <sub>S</sub> + 0.3 V
REFOUT, OUTxP, OUTxN to GND	−0.3 V to V <sub>S</sub> + 0.3 V
Junction Temperature <sup>1</sup>	150°C
Storage Temperature	−65°C to +150°C
Lead Temperature (10 sec)	300°C

<sup>1</sup> See the Thermal Characteristics section for  $\theta_{JA}$ .

Stresses at or above those listed under Absolute Maximum Ratings may cause permanent damage to the product. This is a stress rating only; functional operation of the product at these or any other conditions above those indicated in the operational section of this specification is not implied. Operation beyond the maximum operating conditions for extended periods may affect product reliability.

## THERMAL CHARACTERISTICS

Thermal impedance measurements were taken on a 4-layer board in still air in accordance with EIA/JESD51-7.

Table 14. Thermal Resistance

Package Type	$\theta_{JA}$	Unit
40-Lead LFCSP	27.5	°C/W

## ESD CAUTION



**ESD (electrostatic discharge) sensitive device.** Charged devices and circuit boards can discharge without detection. Although this product features patented or proprietary protection circuitry, damage may occur on devices subjected to high energy ESD. Therefore, proper ESD precautions should be taken to avoid performance degradation or loss of functionality.

## PIN CONFIGURATION AND FUNCTION DESCRIPTIONS

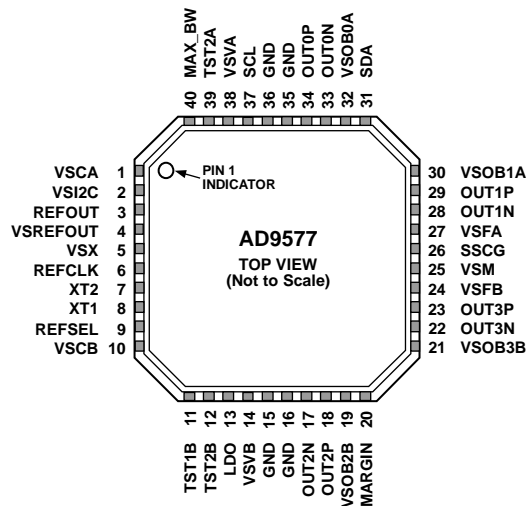

## NOTES

1. THE EXPOSED PADDLE ON THIS PACKAGE IS AN ELECTRICAL CONNECTION AS WELL AS A THERMAL ENHANCEMENT. FOR THE DEVICE TO FUNCTION PROPERLY, THE PADDLE MUST BE ATTACHED TO GROUND (GND). IT IS RECOMMENDED THAT A MINIMUM OF NINE VIAS BE USED TO CONNECT THE PADDLE TO THE PRINTED CIRCUIT BOARD (PCB) GROUND PLANE.

08284-0/05

Figure 5. Pin Configuration

Table 15. Pin Function Descriptions

Pin No.	Mnemonic	Description
1	VSCA	PLL1 Power Supply.
2	VSI2C	I <sup>2</sup> C Digital Power Supply.
3	REFOUT	CMOS Reference Output.
4	VSREFOUT	Reference Output Buffer Power Supply.
5	VSX	Crystal Oscillator and Input Reference Power Supply.
6	REFCLK	Reference Clock Input. Tie low when not in use.
7, 8	XT2, XT1	External 19.44 MHz to 27 MHz Crystal. Leave unconnected when not in use.
9	REFSEL	Logic Input. Use this pin to select the reference source. Internal 30 kΩ pull-up resistor.
10	VSCB	PLL2 Analog Power Supply.
11	TST1B	Test Pin. Connect this pin to Pin 13 (LDO).
12	TST2B	Test Pin. Connect this pin to Pin 13 (LDO).
13	LDO	This pin is for bypassing the PLL2 LDO to ground with a 220 nF capacitor.
14	VSVB	PLL2 VCO Power Supply.
15, 16, 35, 36	GND	Ground.
17	OUT2N	LVPECL/LVDS/CMOS Clock Output.
18	OUT2P	LVPECL/LVDS/CMOS Clock Output.
19	VSOB2B	Output Port OUT2 Power Supply.
20	MARGIN	Logic 1 sets the margining frequency on the clock output pins. Internal 30 kΩ pull-down resistor.
21	VSOB3B	Output Port OUT3 Power Supply.
22	OUT3N	LVPECL/LVDS/CMOS Clock Output.
23	OUT3P	LVPECL/LVDS/CMOS Clock Output.
24	VSFB	PLL2 Analog Power Supply.
25	VSM	PLL2 Digital Power Supply.
26	SSCG	Logic 1 enables spread spectrum operation of PLL2. Internal 30 kΩ pull-down resistor.
27	VSFA	PLL1 Analog Power Supply.
28	OUT1N	LVPECL/LVDS/CMOS Clock Output.
29	OUT1P	LVPECL/LVDS/CMOS Clock Output.

Pin No.	Mnemonic	Description
30	VSOB1A	Output Port OUT1 Power Supply.
31	SDA	Serial Data Line for I <sup>2</sup> C.
32	VSOB0A	Output Port OUT0 Power Supply.
33	OUT0N	LVPECL/LVDS/CMOS Clock Output.
34	OUT0P	LVPECL/LVDS/CMOS Clock Output.
37	SCL	Serial Clock for I <sup>2</sup> C.
38	VSVA	PLL1 VCO Power Supply.
39	TST2A	Test Pin. Connect this pin to the printed circuit board (PCB) ground plane.
40	MAX_BW	Logic 1 widens the loop bandwidth of the fractional-N PLL during spread spectrum. Internal 30 k $\Omega$ pull-down resistor.
	EPAD	The exposed paddle on this package is an electrical connection as well as a thermal enhancement. For the device to function properly, the paddle must be attached to ground (GND). It is recommended that a minimum of nine vias be used to connect the paddle to the printed circuit board (PCB) ground plane.

# TYPICAL PERFORMANCE CHARACTERISTICS

## REFOUT AND PLL1 PHASE NOISE PERFORMANCE

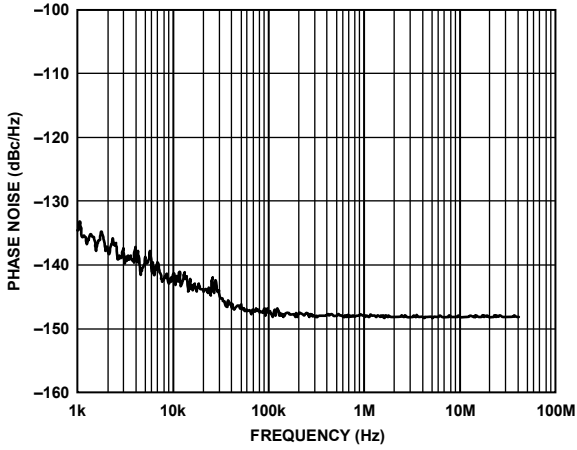

Figure 6. Phase Noise, REFOUT Output, 25 MHz ( $f_{XTAL} = 25$  MHz)

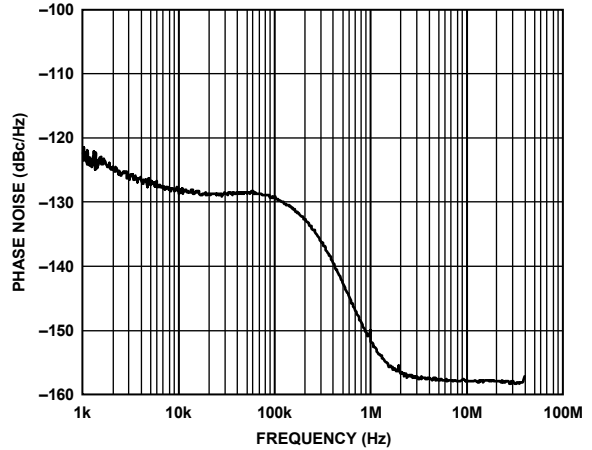

Figure 9. Phase Noise, PLL1, OUT0 LVPECL, 100 MHz, Integer-N Mode ( $f_{XTAL} = 25$  MHz,  $N_a = 100$ ,  $V_0 = 5$ ,  $D_0 = 5$ )

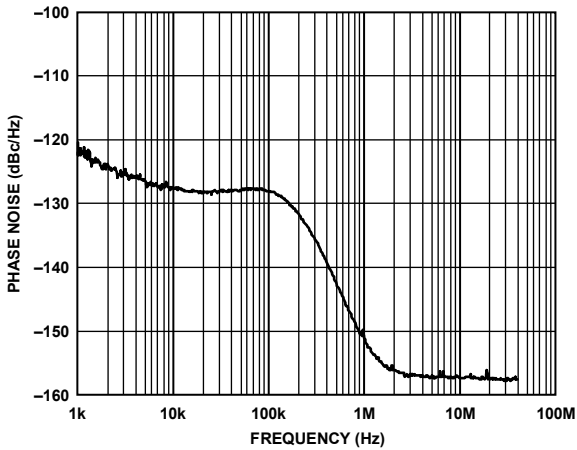

Figure 7. Phase Noise, PLL1, OUT0 LVPECL, 106.25 MHz, Integer-N Mode ( $f_{XTAL} = 25$  MHz,  $N_a = 102$ ,  $V_0 = 4$ ,  $D_0 = 6$ )

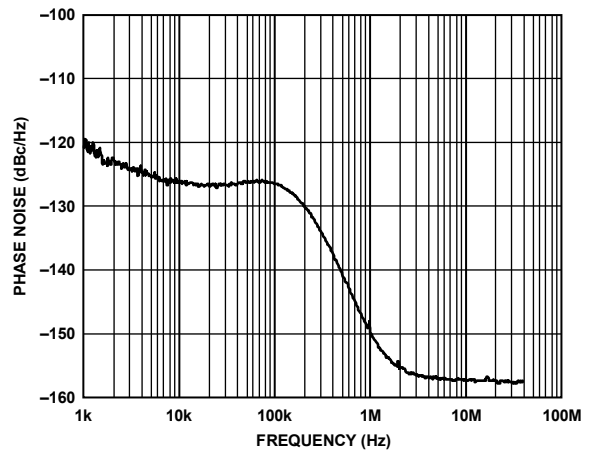

Figure 10. Phase Noise, PLL1, OUT0 LVPECL, 125 MHz, Integer-N Mode ( $f_{XTAL} = 25$  MHz,  $N_a = 100$ ,  $V_0 = 4$ ,  $D_0 = 5$ )

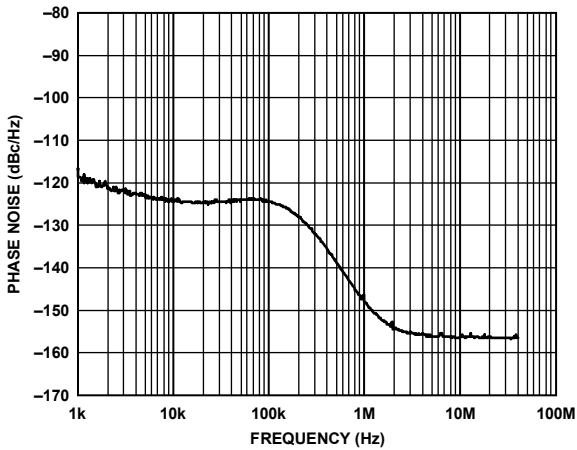

Figure 8. Phase Noise, PLL1, OUT0 LVPECL, 156.25 MHz Integer-N Mode ( $f_{XTAL} = 25$  MHz,  $N_a = 100$ ,  $V_0 = 4$ ,  $D_0 = 4$ )

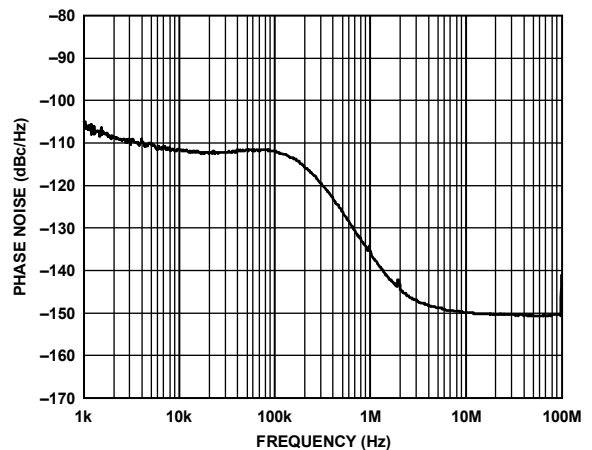

Figure 11. Phase Noise, PLL1, OUT0 LVPECL, 625 MHz, Integer-N Mode ( $f_{XTAL} = 25$  MHz,  $N_a = 100$ ,  $V_0 = 2$ ,  $D_0 = 2$ )

PLL2 PHASE NOISE PERFORMANCE

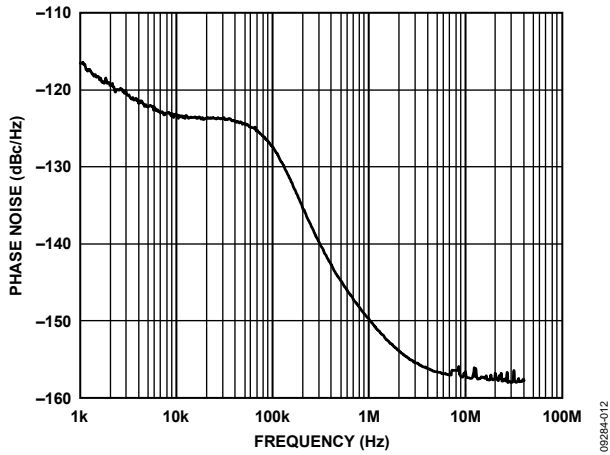

Figure 12. Phase Noise, PLL2, OUT2 LVPECL, 100 MHz, Integer-N Mode ( $f_{XTAL} = 25$  MHz,  $N_b = 100$ ,  $V_2 = 5$ ,  $D_2 = 5$ )

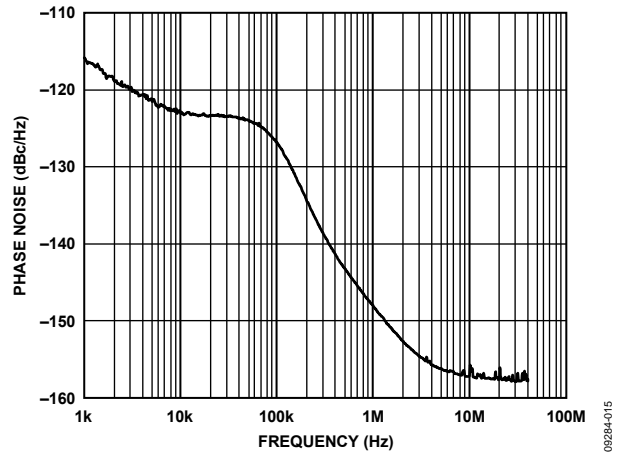

Figure 15. Phase Noise, PLL2, OUT2 LVPECL, 106.25 MHz, Integer-N Mode ( $f_{XTAL} = 25$  MHz,  $N_b = 102$ ,  $V_2 = 4$ ,  $D_2 = 6$ )

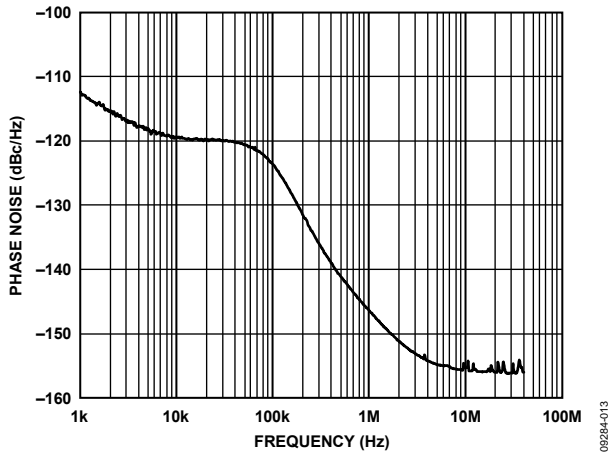

Figure 13. Phase Noise, PLL2, OUT2 LVPECL, 156.25 MHz, Integer-N Mode ( $f_{XTAL} = 25$  MHz,  $N_b = 100$ ,  $V_2 = 4$ ,  $D_2 = 4$ )

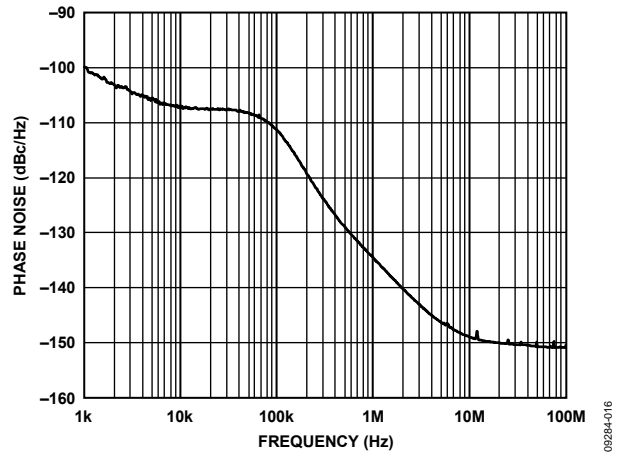

Figure 16. Phase Noise, PLL2, OUT2 LVPECL, 625 MHz, Integer-N Mode ( $f_{XTAL} = 25$  MHz,  $N_b = 100$ ,  $V_2 = 2$ ,  $D_2 = 2$ )

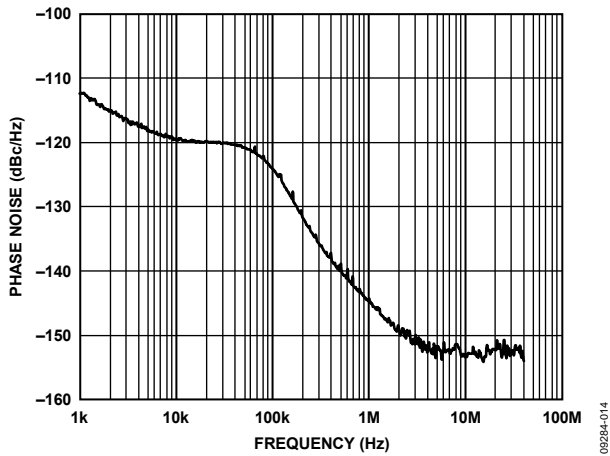

Figure 14. Phase Noise, PLL2, OUT2 LVPECL, 155.52 MHz, Fractional-N Mode ( $f_{XTAL} = 25$  MHz,  $N_b = 99$ ,  $FRAC = 333$ ,  $MOD = 625$ ,  $V_2 = 2$ ,  $D_2 = 8$ ), Spurs Disabled

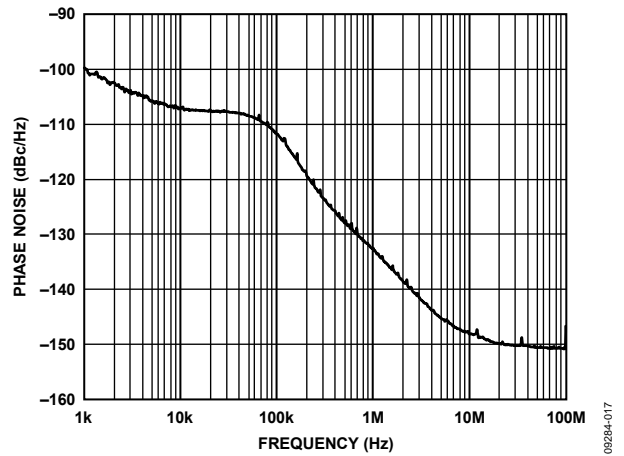

Figure 17. Phase Noise, PLL2, OUT2 LVPECL, 622.08 MHz, Fractional-N Mode ( $f_{XTAL} = 25$  MHz,  $N_b = 99$ ,  $FRAC = 333$ ,  $MOD = 625$ ,  $V_2 = 2$ ,  $D_2 = 2$ ), Spurs Disabled

**OUTPUT JITTER**

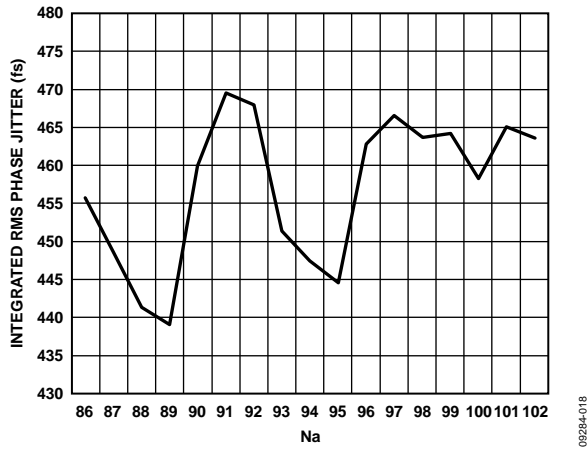

Figure 18. Typical Integrated Random Phase Jitter in fs rms for PLL1 and OUT0P LVPECL as Feedback Divider Value Na Swept ( $f_{XTAL} = 25$  MHz,  $V0 = 5$ ,  $D0 = 5$ )

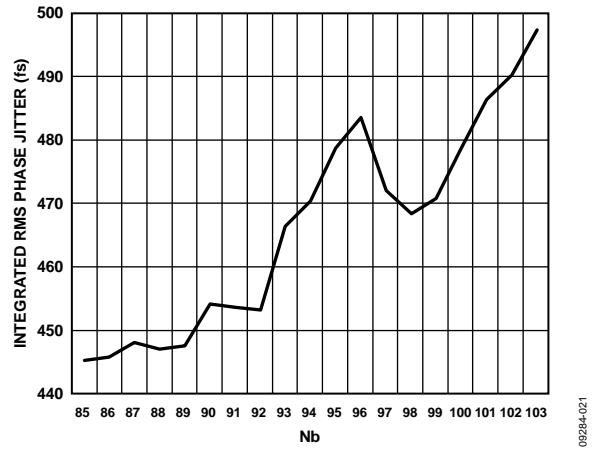

Figure 19. Typical Integrated Random Phase Jitter in fs rms for PLL2 and OUT2P LVPECL as Feedback Divider Value Nb Swept ( $f_{XTAL} = 25$  MHz,  $V2 = 5$ ,  $D2 = 5$ , Integer-N Mode)

TYPICAL OUTPUT SIGNAL

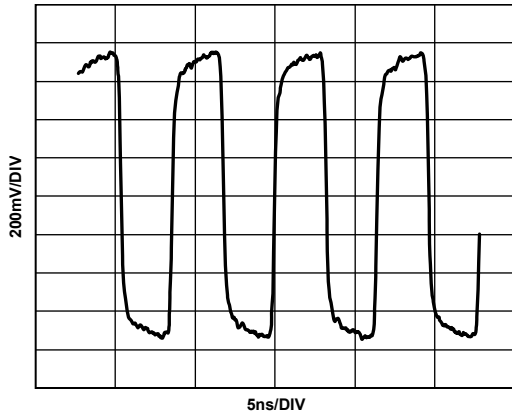

Figure 20 Typical LVPECL Differential Output Trace, 156.25 MHz

09284-024

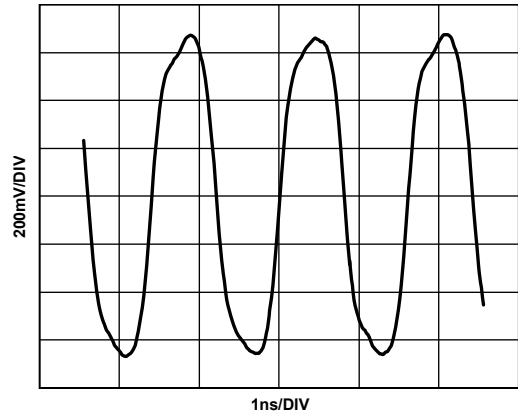

Figure 23. Typical LVPECL Differential Output Trace, 625 MHz

09284-027

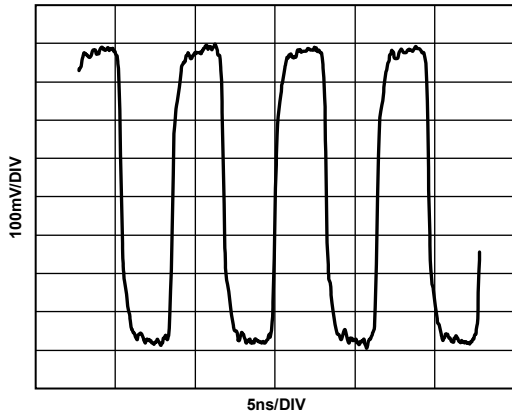

Figure 21. Typical LVDS Differential Output Trace, 156.25 MHz

09284-025

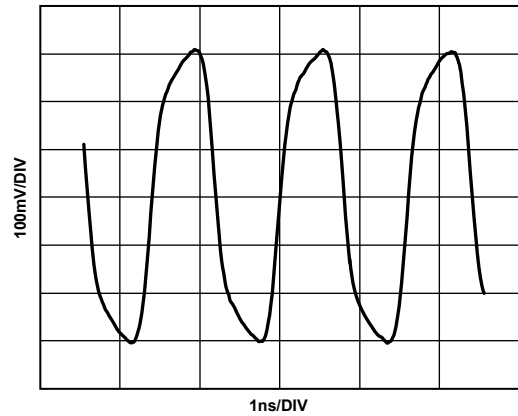

Figure 24. Typical LVDS Differential Output Trace, 625 MHz

09284-028

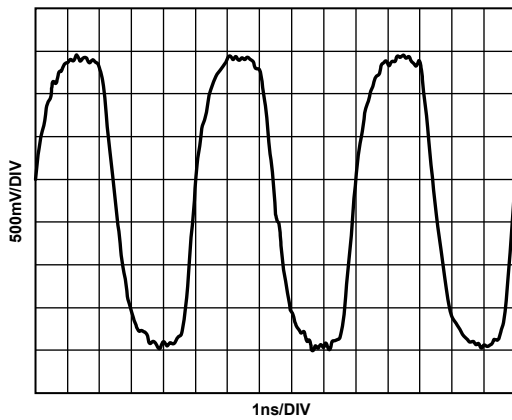

Figure 22. Typical CMOS Output Trace, 200MHz

09284-026

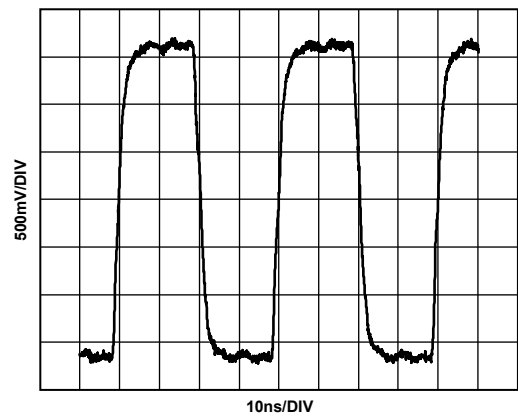

Figure 25. Typical REFOUT Output Trace, 25 MHz

09284-029

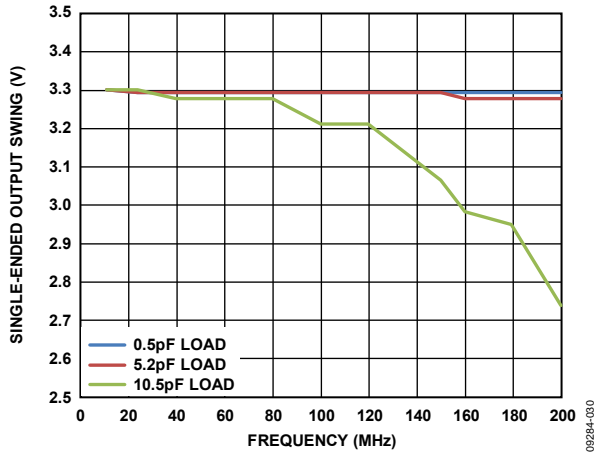

Figure 26. CMOS Single-Ended, Peak-to-Peak Output Swing vs. Frequency, for Loads of 0.5 pF, 5.2 pF, and 10.5 pF, Measured with a Tektronix P7313 Active Probe

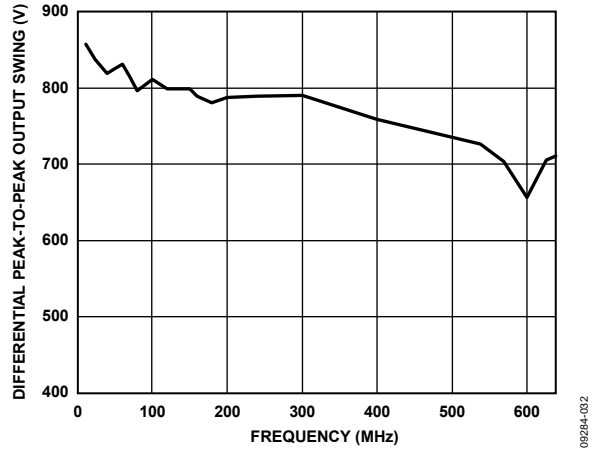

Figure 28. LVDS Differential, Peak-to-Peak Output Swing vs. Frequency

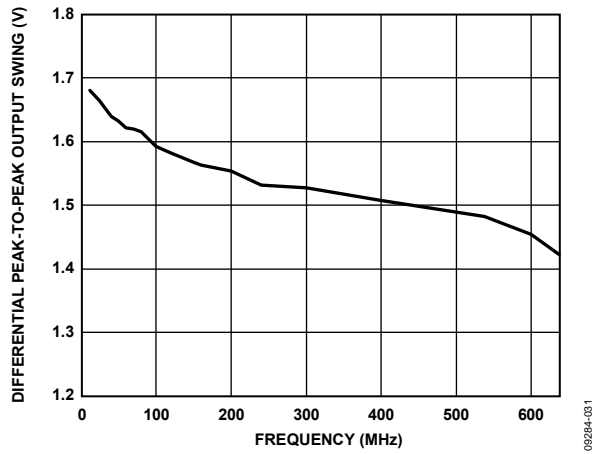

Figure 27. LVPECL Differential, Peak-to-Peak Output Swing vs. Frequency

TYPICAL SPREAD SPECTRUM PERFORMANCE CHARACTERISTICS

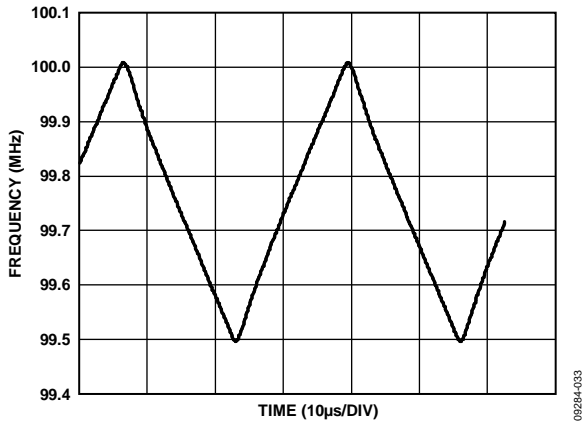

Figure 29. Typical Spread Spectrum Frequency Modulation Profile OUT2, Nb = 96, FRAC = 0, MOD = 1000, CkDiv = 7, NumSteps = 59, FracStep = -8, f<sub>OUT</sub> = 100 MHz with -0.5% Downspread at 30.2 kHz, MAX\_BW set to 0

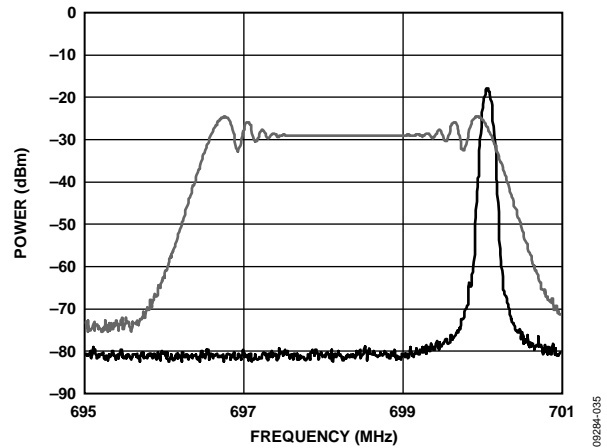

Figure 31. Typical Nonspread and Spread Spectrum Power Spectra, OUT2, Nb = 96, FRAC = 0, MOD = 1000, CkDiv = 7, NumSteps = 59, FracStep = -8, f<sub>OUT</sub> = 100 MHz with -0.5% Downspread at 30.2 kHz, MAX\_BW set to 0, Seventh Harmonic Shown, Spectrum Analyzer Resolution Bandwidth = 120 kHz, Maximum Hold On

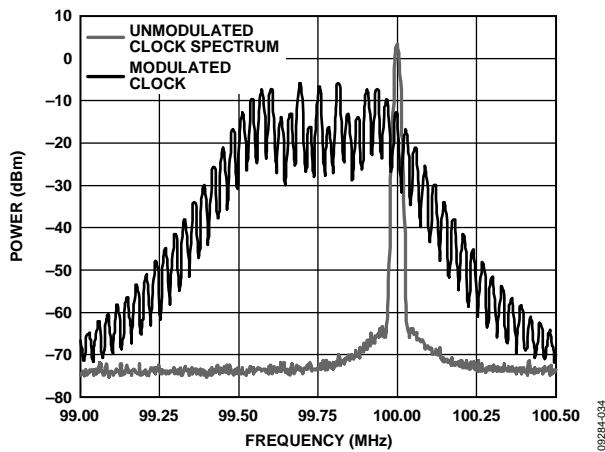

Figure 30. Typical Nonspread and Spread Spectrum Power Spectra, OUT2, Nb = 96, FRAC = 0, MOD = 1000, CkDiv = 7, NumSteps = 59, FracStep = -8, f<sub>OUT</sub> = 100 MHz with -0.5% Downspread at 30.2 kHz, MAX\_BW set to 0, First Harmonic Shown, Spectrum Analyzer Resolution Bandwidth = 10 kHz, Maximum Hold On

## TERMINOLOGY

### Phase Jitter and Phase Noise

An ideal sine wave can be thought of as having a continuous and even progression of phase with time from 0° to 360° for each cycle. Actual signals, however, display a certain amount of variation from ideal phase progression over time, which is called phase jitter. Although many causes can contribute to phase jitter, one major cause is random noise, which is characterized statistically as being Gaussian (normal) in distribution.

This phase jitter leads to a spreading out of the energy of the sine wave in the frequency domain, producing a continuous power spectrum. This power spectrum is usually reported as a series of values whose units are dBc/Hz at a given offset in frequency from the sine wave (carrier). The value is a ratio (expressed in dB) of the power contained within a 1 Hz bandwidth with respect to the power at the carrier frequency. For each measurement, the offset from the carrier frequency is also given.

It is meaningful to integrate the total power contained within some interval of offset frequencies (for example, 12 kHz to 20 MHz). This is called the integrated phase noise over that frequency offset interval and can be readily related to the time jitter due to the phase noise within that offset frequency interval.

Phase noise has a detrimental effect on error rate performance by increasing eye closure at the transmitter output and reducing the jitter tolerance/sensitivity of the receiver.

### Time Jitter

Phase noise is a frequency domain phenomenon. In the time domain, the same effect is exhibited as time jitter. When observing a sine wave, the time of successive zero crossings vary. In a square wave, the time jitter is seen as a displacement of the edges from their ideal (regular) times of occurrence. In both cases, the variations in timing from the ideal are the time jitter. Because these variations are random in nature, the time jitter is specified in units of seconds root mean square (rms) or 1 sigma of the Gaussian distribution.

### Additive Phase Noise

It is the amount of phase noise that is attributable to the device or subsystem being measured. The phase noise of any external oscillators or clock sources has been subtracted. This makes it possible to predict the degree to which the device affects the total system phase noise when used in conjunction with the various oscillators and clock sources, each of which contributes its own phase noise to the total. In many cases, the phase noise of one element dominates the system phase noise.

### Additive Time Jitter

It is the amount of time jitter that is attributable to the device or subsystem being measured. The time jitter of any external oscillators or clock sources has been subtracted. This makes it possible to predict the degree to which the device will affect the total system time jitter when used in conjunction with the various oscillators and clock sources, each of which contributes its own time jitter to the total. In many cases, the time jitter of the external oscillators and clock sources dominates the system time jitter.

### Random Jitter Measurement

On the AD9577, the rms jitter measurements are made by integrating the phase noise, with spurs disabled. There are two reasons for this. First, because the part is highly configurable, any measured spurs are a function of the current programmed state of the device. For example, there may be a small reference spur at the PFD frequency present on the output spectrum. If the PFD operates at 19.44 MHz (which is common for telecommunications applications), the resulting jitter falls within the normal 12 kHz to 20 MHz integration bandwidth. When the PFD operates above 20 MHz, the deterministic jitter is not included in the measurement. As another example, for PLL2, the value of the chosen FRAC and MOD values affects the amplitude and location of a spur, and therefore, it is not possible to configure the PLL to provide a general measurement that includes spurs.

The second, and more significant reason, is due to the statistical nature of spurious components. The jitter performance information of the clock generator is required so that a jitter budget for the complete communications channel can be established. By knowing the jitter characteristics at the ultimate receiver, the data bit error rate (BER) can be estimated to ensure robust data transfer. The received jitter characteristic consists of random jitter (RJ), due to random perturbations such as thermal noise, and deterministic jitter (DJ), due to deterministic perturbations such as crosstalk spurs. To make an estimate of the BER, the total jitter peak-to-peak (TJ p-p) value must be known. It is the total jitter value that determines the amount of eye closure at the receiver and, consequently, the bit error rate. The TJ p-p value is specified for a given number of clock edges. For example, in networking applications, the TJ is specified for 1<sup>12</sup> clock edges. The equation for the total jitter peak-to-peak is

$$TJ_{p-p} = DJ_{p-p} + 2 \times Q \times RJ_{rms} \quad (1)$$

where the  $Q$  factor represents the ratio of the expected peak deviation to the standard deviation in a Gaussian process for a given population (of edge crossings). For 1<sup>12</sup> clock edges,  $Q$  is 7.03; therefore, for networking applications, the total jitter peak-to-peak is estimated by

$$TJ_{p-p} = DJ_{p-p} + 14.06 \times RJ_{rms} \quad (2)$$

Therefore, to accurately estimate the TJ p-p, separate measurements of the rms value of the random jitter (RJ rms) and the peak-to-peak value of the deterministic jitter (DJ p-p) must be taken. To measure the RJ rms of the clock signal, integrate the clock phase noise over the desired bandwidth, with spurs disabled (that is, removed) from the measurement. If the DJ spurs were included in the measurement, the DJ contribution would also be multiplied by 14.06 in Equation 2, leading to a grossly pessimistic estimate of the total jitter. This is why it is important to measure the integrated jitter with spurs

disabled. Due to the 14.06 factor in Equation 2, the spurious DJ components on the clock output only have a small impact on the TJ p-p measurement and, consequently, the system BER performance. Therefore, it is clear that the DJ component (that is, the spur) should not be added to the rms value of the random jitter directly. However, if the phase noise jitter measurement was performed with spurs enabled, this is exactly what the measurement would be reporting. For more background information, see *Fibre Channel, Methodologies for Jitter and Signal Quality Specification-MJSQ*, Rev. 14, June 9, 2004.

DETAILED BLOCK DIAGRAM

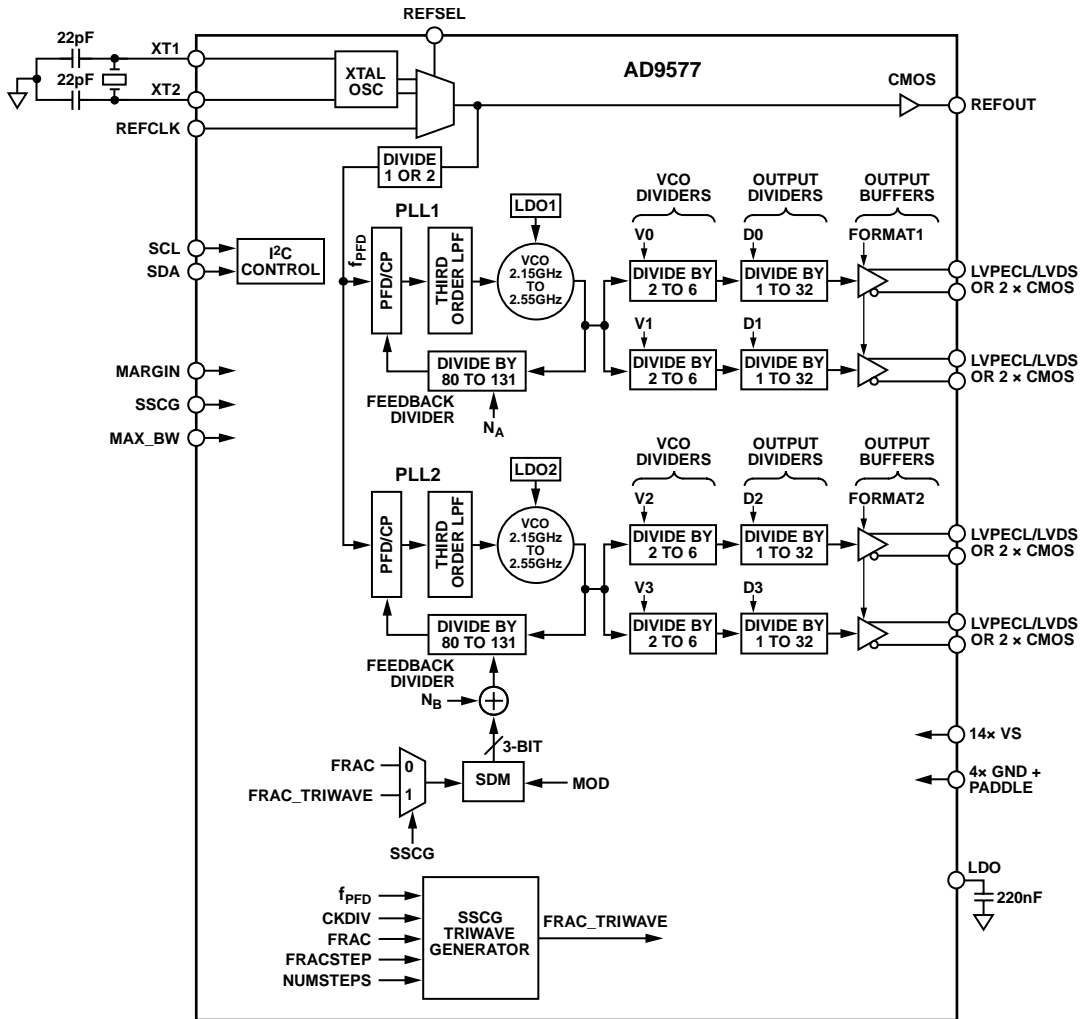

Figure 32. Detailed Block Diagram

092284-036

EXAMPLE APPLICATION

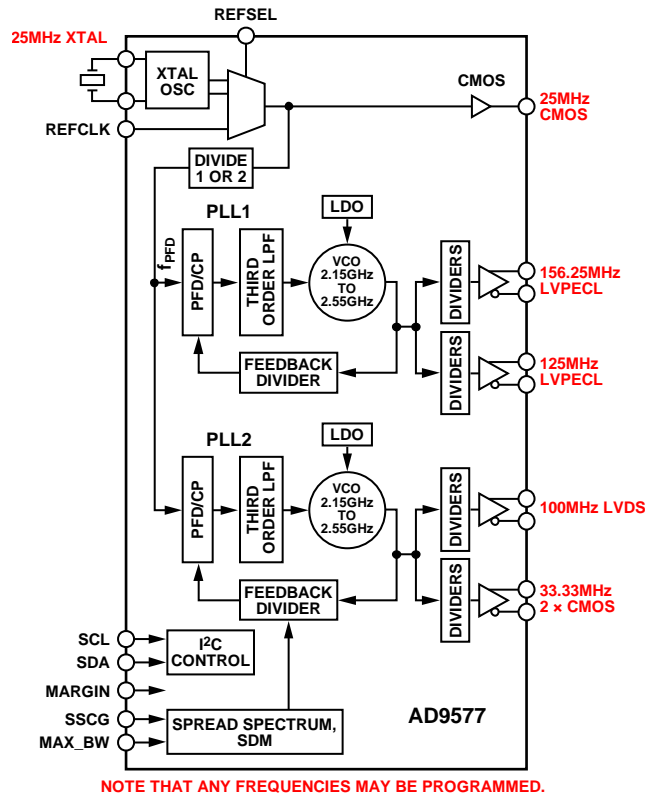

Figure 33. Example Application

Achievable application frequencies include (but are not limited to) those listed in Table 16.

Table 16. Typical Application Frequencies

Applications	Frequency (MHz)
Ethernet	25, 62.5, 100, 125, 250
10G Ethernet	155.52, 156.25, 187.5, 161.1328125, 312.5, 622.08, 625
FB-DIMM	133.333, 166.666, 200
Fibre Channel	53.125, 106.25, 212.5, 318.75, 425
10G Fibre Channel	159.375
Infiniband	125
SAS, SATA	37.5, 75, 100, 120, 150; the AD9577 also meets the -0.5% downspread requirement
Telecomm	19.44, 38.88, 77.76, 155.52, 311.04, 622.08, 627.32962
PCI Express	100, 125, 250; the AD9577 also meets the -0.5% downspread requirement
PCI, PCI-X	33.33, 66.66, 100, 133.33, 200
Video	13.5, 14.318, 17.7, 18, 27, 72, 74.25, 74.25/1.001, 148.5, 148.5/1.001
Wireless Infrastructure	61.44, 122.88, 368.64

## FUNCTIONAL DESCRIPTION

On the AD9577, parameters can be programmed over an I<sup>2</sup>C bus to provide custom output frequencies, output formats, and feature selections. However, this programming must be repeated after every power cycle of the part.

The AD9577 contains two PLLs, PLL1 and PLL2, used for independent clock frequency generation, as shown in Figure 32. A shared crystal oscillator and reference clock input cell drive both PLLs. The reference clock of the PLLs can be selected as either the crystal oscillator output or the reference input clock. A reference divider precedes each PLL. When the crystal oscillator input is selected, these dividers must be set to divide by 1. When the reference input is selected, these dividers can be set to divide by 1 or divide by 2, provided that the resulting input frequency to the PLLs is within the permitted 19.44 MHz to 27 MHz range. Both reference dividers are set to divide by the same value. Each PLL drives two output channels, producing four output ports in total for the IC. Each output channel consists of a VCO divider block, followed by an output divider block. The output divider blocks each drive with an output buffer port. Each output buffer port can be configured as a differential LVDS output, a differential LVPECL output, or two LVCMOS outputs. Additionally, a CMOS-buffered version reference clock frequency is available.

The upper PLL in Figure 32, PLL1, is an integer-N PLL. By setting the feedback divider value (Na), the VCO output frequency can be tuned over the 2.15 GHz to 2.55 GHz range to integer multiples of the PFD input frequency. By setting each of the VCO divider (V0 and V1) and output divider (D0 and D1) values, the VCO frequency can be divided down to the required output frequency, independently, for each of the output ports, OUT0 and OUT1. The loop filter required for this PLL is integrated on chip.

The lower PLL in Figure 32, PLL2, is a fractional-N PLL. This PLL can optionally operate as an integer-N PLL for optimum jitter performance. By setting the feedback divider value (Nb) and the  $\Sigma$ - $\Delta$  modulator fractional (FRAC) and modulus (MOD) values, the VCO output frequency can tune over the 2.15 GHz to 2.55 GHz range. The VCO frequency is a fractional multiple of the PFD input frequency. In this way, the VCO frequency can tune to obtain frequencies that are not constrained to integer multiples of the PFD frequency. By setting each of the VCO divider (V2 and V3) and output divider (D2 and D3) values, the VCO frequency can be divided down to the required output frequency, independently, for each of the output ports, OUT2 and OUT3. The loop filters required for this PLL are integrated on chip.

The PLL2 can operate to modulate the output frequency between its nominal value and a value that is up to  $-0.5\%$  lower. This provides spread spectrum modulation up to  $-0.5\%$  downspread. Spread spectrum frequency modulation can reduce the peak power output of the clock source and any circuitry that it drives and lead to reduced EMI emissions. In the AD9577, the frequency modulation profile is triangular. The modulation frequency and modulation range parameters are all programmable.

Both PLLs can be programmed to generate a second independent frequency map under the control of the MARGIN pin. This feature can be used to test the frequency robustness of a system.

### REFERENCE INPUT AND REFERENCE DIVIDERS

The reference input section is shown in Figure 34. When the REFSEL pin is pulled high, the crystal oscillator circuit is enabled. The crystal oscillator circuit needs an external crystal cut to resonate in fundamental mode in the 19.44 MHz to 27 MHz range, with 25 MHz being used in most networking applications. The total load capacitance presented to the crystal should add up to 14 pF. In the example shown in Figure 34, parasitic trace capacitance of 1.5 pF and an AD9577 input pin capacitance of 1.5 pF are assumed, with the series combination of the two 22 pF capacitances providing an additional 11 pF. When the REFSEL pin is pulled low, the crystal oscillator powers down, and the REFCLK pin must provide a good quality reference clock instead. Either a dc-coupled LVCMOS level signal or an ac-coupled square wave can drive this single-ended input, provided that an external potential divider is used to bias the input at  $V_s/2$ .

The output of the crystal oscillator and reference input circuitry is routed to a reference divider circuit to further divide down the reference input frequency to the PLLs by 1 or 2. When the crystal oscillator circuit is used, the dividers must be set to divide by 1. The input frequency to the PLLs must be in the 19.44 MHz to 27 MHz range. The divide ratio is set to 1 by programming the value of R, Register G0[1], to 0. The divide ratio is set to 2 by programming the value of R to 1.

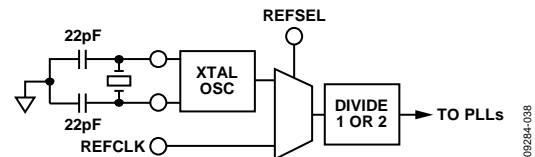

Figure 34. Reference Input Section and Reference Dividers

Table 17. REFSEL (Pin 9) Definition

REFSEL	Reference Source
0	REFCLK input
1	Crystal oscillator

Table 18. Reference Divider Setting

R, Register G0[1]	Reference Divide Ratio
0	Divide by 1
1	Divide by 2

**OUTPUT CHANNEL DIVIDERS**

Between each VCO and its associated chip outputs, there are two divider stages: a VCO divider that has a divide ratio between 2 and 6 and an output divider that can be set to divide between 1 and 32. This cascade of dividers allows a minimum output channel divide ratio of 2 and a maximum of 192. With VCO frequencies ranging between 2.15 GHz and 2.55 GHz, the part can be programmed to spot frequencies over a continuous frequency range of from 11.2 MHz to 200 MHz, and it can be programmed to spot frequencies over a continuous frequency range of 200 MHz and 637.5 MHz, with only a few small gaps.

**Table 19. Divider Ratio Setting Registers**

Divider	I <sup>2</sup> C Registers	Parameter	Divide Range
Channel 0 VCO divider	ADV0[7:5]	V0	2 to 6
Channel 1 VCO divider	ADV1[7:5]	V1	2 to 6
Channel 2 VCO divider	BDV0[7:5]	V2	2 to 6
Channel 3 VCO divider	BDV1[7:5]	V3	2 to 6
Channel 0 output divider	ADV0[4:0]	D0	1 to 32 <sup>1</sup>
Channel 1 output divider	ADV1[4:0]	D1	1 to 32 <sup>1</sup>
Channel 2 output divider	BDV0[4:0]	D2	1 to 32 <sup>1</sup>
Channel 3 output divider	BDV1[4:0]	D3	1 to 32 <sup>1</sup>

<sup>1</sup> Set to 00000 for divide by 32.

Asserting the SyncCh01 or SyncCh23 bits (Register ADV2[0] or Register BDV2[0]) allows each PLL output channel to use a common VCO divider. This feature allows the OUT0/OUT1 and OUT2/OUT3 output ports to have minimal skew when their relative output channel divide ratio is an integer multiple. Duty-cycle correction circuitry ensures that the output duty cycle remains at 50%.

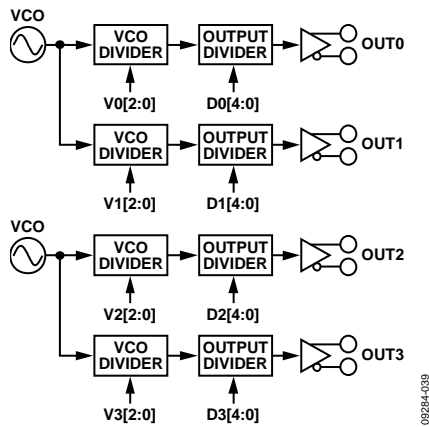

Figure 35. Output Channel Divider Signal Path

**OUTPUTS**

Each output port can be individually configured as either differential LVPECL, differential LVDS, or two single-ended LVCMOS clock outputs. The simplified equivalent circuit of the LVDS outputs is shown in Figure 36.

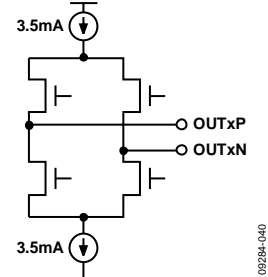

Figure 36. LVDS Outputs Simplified Equivalent Circuit

The simplified equivalent circuit of the LVPECL outputs is shown in Figure 37.

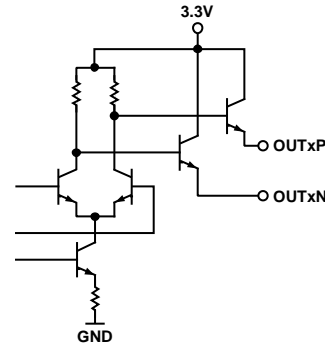

Figure 37. LVPECL Outputs Simplified Equivalent Circuit

Output channels (consisting of a VCO divider, output divider, and an output buffer) can be individually powered down to save power. Setting PDCH1 (Register BP0[1]) and PDCH3 (Register DR1[7]) powers down the respective channel. Setting PDCH0 (Register BP0[0]) powers down both Channel 0 and Channel 1. Setting PDCH2 (Register DR1[6]) powers down both Channel 2 and Channel 3.

Output buffer combinations of LVDS, LVPECL, and CMOS can be selected by setting DR1[5:0] as is shown in Table 20 and Table 21.

**Table 20. PLL1 Output Driver Format Control Bits, Register DR1[2:0]**

FORMAT1 (PLL1) Register DR1[2:0]	OUT1P/OUT1N	OUT0P/OUT0N
000	LVPECL	LVPECL
001	LVDS	LVDS
010	2 × CMOS	LVPECL
011	2 × CMOS	2 × CMOS
100	2 × CMOS	LVDS
101	LVPECL	LVDS
110	LVPECL	2 × CMOS
111 <sup>1</sup>	2 × CMOS	2 × CMOS

<sup>1</sup> This indicates that the CMOS outputs are in phase; otherwise, they are in antiphase.

**Table 21. PLL2 Output Driver Format Control Bits, Register DR1[5:3]**

FORMAT2 (PLL2) Register DR1[5:3]	OUT3P/OUT3N	OUT2P/OUT2N
000	LVPECL	LVPECL
001	LVDS	LVDS
010	2 × CMOS	LVPECL
011	2 × CMOS	2 × CMOS
100	2 × CMOS	LVDS
101	LVPECL	LVDS
110	LVPECL	2 × CMOS
111 <sup>1</sup>	2 × CMOS	2 × CMOS

<sup>1</sup> This indicates that the CMOS outputs are in phase; otherwise, they are antiphase.

LVDS uses a current mode output stage. The normal value (default) for this current is 3.5 mA, which yields a 350 mV output swing across a 100 Ω resistor. The LVDS outputs meet or exceed all ANSI/TIA/EIA-644 specifications. The LVDS output buffer should be terminated with a 100 Ω differential resistor between the receiver input ports (see Figure 38). A recommended termination circuit for the LVDS outputs is shown in Figure 38.

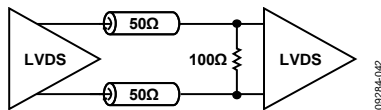

Figure 38. LVDS Output Termination

See the [AN-586 Application Note, LVDS Outputs for High Speed A/D Converters](#), for more information about LVDS.

In a dc-coupled application, the LVPECL output buffer must be terminated via a pair of 50 Ω resistors to a voltage of  $V_{CC} - 2V$ . This can be implemented by using potential dividers of 127 Ω and 83 Ω between the supplies, as shown in Figure 39.

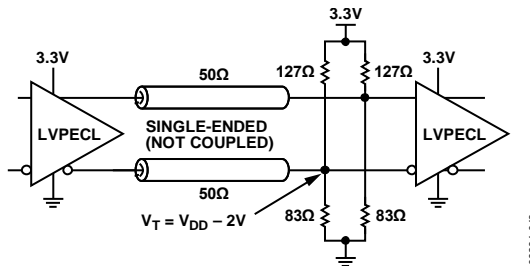

Figure 39. LVPECL DC-Coupled Termination

An alternative LVPECL termination scheme for dc-coupled applications is shown Figure 40.

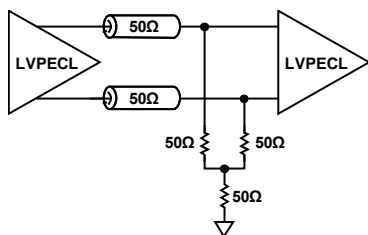

Figure 40. LVPECL DC-Coupled Y-Termination

In ac-coupled applications, the LVPECL output stage needs a pair of 200 Ω pull-down resistors to GND to provide a dc path for the output stage emitter followers (see Figure 41). The receiver must provide an additional 50 Ω single-ended input termination.

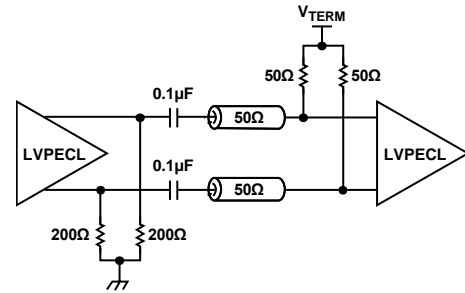

Figure 41. LVPECL AC-Coupled Termination

### REFERENCE OUTPUT BUFFER

A CMOS buffered copy of the reference input circuit signal is available at the REFOUT pin. This buffer can be optionally powered down by setting Register DR2[0], PDRefOut to Logic 0.

### PLL1 INTEGER-N PLL

The upper PLL in Figure 32, PLL1, is an integer-N PLL with a loop bandwidth of 140 kHz. The input frequency to the PLL from the reference circuit is  $f_{PFD}$ . The VCO frequency,  $f_{VCO1}$ , is programmed by setting the value for  $N_a$ , according to

$$f_{VCO1} = f_{PFD} \times N_a \tag{3}$$

where  $N_a$  is programmable in the 80 to 131 range. The VCO output frequency can tune over the 2.15 GHz to 2.55 GHz range to integer multiples of the PFD input frequency only.

By setting each of the VCO divider ( $V_0$  and  $V_1$ ) and output divider ( $D_0$  and  $D_1$ ) values, the VCO frequency can be divided down to the required output frequency, independently, for each of the output ports, OUT0 and OUT1. The  $f_{OUT0}$  frequency presented to OUT0 can be set according to

$$f_{OUT0} = f_{PFD} \times \frac{N_a}{V_0 \times D_0} \tag{4}$$

The frequency  $f_{OUT1}$  presented to OUT1 can be set according to

$$f_{OUT1} = f_{PFD} \times \frac{N_a}{V_1 \times D_1} \tag{5}$$

The loop filters required for this PLL are integrated on chip.

## PLL1 PHASE FREQUENCY DETECTOR (PFD) AND CHARGE PUMP

The PFD determines the phase difference error between the reference divider output and the feedback divider output clock edges. The outputs of this circuit are pulse-width modulated up and down signal pulses. These pulses drive the charge pump circuit. The amount of charge delivered from the charge pump to the loop filter is determined by the instantaneous phase error. The action of the closed loop is to drive the frequency and phase error at the input of the PFD toward zero. Figure 42 shows a block diagram of the PFD/CP circuitry.

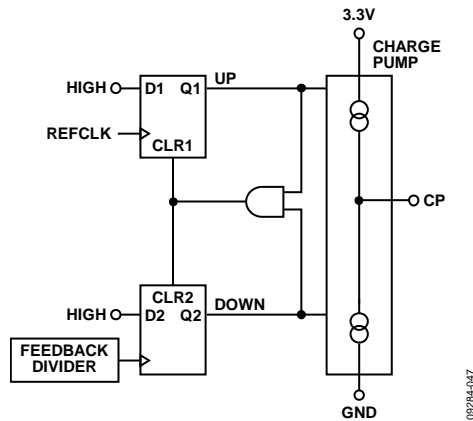

Figure 42. PFD Circuit Showing Simplified Charge Pump

## PLL1 VCO

PLL1 incorporates a low phase noise LC-tank VCO. This VCO has 32 frequency bands spanning from 2.15 GHz to 2.55 GHz. At power-up, a VCO calibration cycle begins and the correct band is selected based on the feedback divider setting ( $N_a$ ). Whenever a new feedback divider setting is called for, the VCO calibration process must run by writing 1 followed by 0 to the NewAcq bit, Register X0[0].

## PLL1 FEEDBACK DIVIDER

The feedback divider ratio,  $N_a$ , is used to set the PLL1 VCO frequency according to Equation 3. Note that the  $N_a$  value is set by adding the offset value of 80 to the value programmed to Register AF0[5:0], where 80 is the minimum divider  $N_a$  value. The maximum  $N_a$  value is 131. For example, to set  $N_a$  to 85, the AF0[5:0] register is set to 5.

## SETTING THE OUTPUT FREQUENCY OF PLL1

For example, set the output frequency ( $f_{OUT0}$ ) on Port 0 to 156.25 MHz, the output frequency ( $f_{OUT1}$ ) on Port 1 to 100 MHz, and both the reference frequency ( $f_{REF}$ ) and the PFD frequency ( $f_{PFD}$ ) to 25 MHz.

The frequency  $f_{OUT0}$  presented to OUT0 can be set according to Equation 4.

The frequency  $f_{OUT1}$  presented to OUT1 can be set according to Equation 5.

To determine if both 156.25 MHz and 100 MHz can be derived from a common  $f_{VCO1}$  frequency in the 2.15 GHz to 2.55 GHz range, use the lowest common multiple (LCM) of 156.25 MHz and 100 MHz to determine the lowest VCO frequency that can be divided down to provide both of these frequencies.

$$LCM(156.25 \text{ MHz}, 100 \text{ MHz}) = 2.5 \text{ GHz} \quad (6)$$

Therefore, set the VCO frequency to 2.5 GHz. With  $f_{PFD} = 25 \text{ MHz}$ , from Equation 3,  $N_a$  must be set to 100.

For 156.25 MHz on Port 0, set

$$V0 \times D0 = 16 \quad (7)$$

This can be achieved by setting  $V0$  to 4 and  $D0$  to 4. For 100 MHz on Port 1, set

$$V1 \times D1 = 25 \quad (8)$$

This can be achieved by setting  $V1$  to 5 and  $D1$  to 5. With a reference frequency of 25 MHz, the reference divider value,  $R$ , must be set to 1 by setting Register G0[1] to 0. Table 22 summarizes the register settings for this configuration.

Table 22. Register Settings for Example PLL1 Configuration

Parameter	Divide Value	I <sup>2</sup> C Register	Register Value
$N_a$	100	AF0[5:0]	010100
$V0$	4	ADV0[7:5]	100
$D0$	4	ADV0[4:0]	00100
$V1$	5	ADV1[7:5]	101
$D1$	5	ADV1[4:0]	00101
$R$	1	G0[1]	1

## PLL2 INTEGER/FRACTIONAL-N PLL

The lower PLL in Figure 32, PLL2, is a fractional-N PLL. The input frequency to the PLL from the reference circuit is  $f_{PFD}$ . The VCO frequency,  $f_{VCO2}$ , is programmed by setting the values for  $N_b$ ,  $FRAC$ , and  $MOD$  according to

$$f_{VCO2} = f_{PFD} \times \left( N_b + \frac{FRAC}{MOD} \right) \quad (9)$$

where  $N_b$  is programmable in the 80 to 131 range. To provide the greatest flexibility and accuracy, both the  $FRAC$  and  $MOD$  values can be programmed to a resolution of 12 bits, where  $FRAC < MOD$ . The VCO output frequency can tune over the 2.15 GHz to 2.55 GHz range to fractional multiples of the PFD input frequency.

By setting each of the VCO divider ( $V2$  and  $V3$ ) and output divider ( $D2$  and  $D3$ ) values, the VCO frequency can be divided down to the required output frequency, independently, for each of the output ports, OUT2 and OUT3. The  $f_{OUT2}$  frequency presented to OUT2 can be set according to

$$f_{OUT2} = f_{PFD} \times \frac{\left( N_b + \frac{FRAC}{MOD} \right)}{V2 \times D2} \quad (10)$$

The  $f_{OUT3}$  frequency presented to OUT3 can be set according to

$$f_{OUT3} = f_{PFD} \times \frac{(Nb + \frac{FRAC}{MOD})}{V3 \times D3} \quad (11)$$

The loop filters required for this PLL are integrated on chip.

By setting the FRAC value to 0, powering down the SDM by setting Register ABF0[4] to 1, and turning the bleed current off by setting Register BP0[2] = 0, PLL2 can operate as an integer-N PLL. Equation 10 and Equation 11 are still used to set the output frequencies for  $f_{OUT2}$  and  $f_{OUT3}$ . Operation in this mode provides improved performance in terms of phase noise, spurs, and jitter.

### PLL2 PHASE FREQUENCY DETECTOR (PFD) AND CHARGE PUMP

The PLL2 PFD and charge pump is the same as that described in the PLL1 Phase Frequency Detector (PFD) and Charge Pump section. When operating in fractional-N mode, a charge pump bleed current should be enabled to linearize the PLL transfer function and, therefore, to minimize spurs due to the operation of the  $\Sigma$ - $\Delta$  modulator. Bleed is enabled by setting Register BP0[2].

### PLL2 LOOP BANDWIDTH

The normal PLL loop bandwidth is 50 kHz. When the SSCG input pin is asserted, the loop bandwidth switches from 50 kHz to 125 kHz, which prevents the triangle-wave modulation waveform from being overly filtered by the PLL. When the MAX\_BW input pin is set high, it forces the PLL bandwidth to be 250 kHz instead of 125 kHz.

### PLL2 VCO

PLL2 incorporates a low phase noise LC-tank VCO. This VCO has 32 frequency bands spanning from 2.15 GHz to 2.55 GHz. At power-up, a VCO calibration cycle begins and the correct band is selected based on the feedback divider setting (Nb). Whenever a new feedback divider setting is called for, the VCO calibration process must run by writing 1 followed by 0 to the NewAcq bit, Register X0[0].

### PLL2 FEEDBACK DIVIDER

The Nb feedback divider ratio is used to set the PLL2 VCO frequency according to Equation 9. Note that the Nb value is set by adding the decimal value programmed to Register BF3[5:0] to a decimal value of 80, where the minimum divider Nb value is 80. The maximum Nb value is 131. For example, to set Nb to 85, Register BF3[5:0] is set to 5.

### PLL2 $\Sigma$ - $\Delta$ MODULATOR

When operating in fractional-N mode only, PLL2 uses a third-order, multistage noise shaping (MASH)  $\Sigma$ - $\Delta$  modulator (SDM) to adjust the feedback divider ratio. The programmed Nb value can be adjusted over the -4 to +3 range on every rising clock edge from the feedback divider output (typically 25 MHz for networking applications). In this way, the average feedback divide ratio is adjusted to be a noninteger value, allowing for a VCO frequency that is a fractional multiple of the PFD frequency to be

synthesized. By setting the FRAC and MOD values of the SDM, the PLL2 VCO frequency can be set according to Equation 9. The SDM must be turned on by setting PD\_SDM to 0, Register ABF0[4].

### 12-Bit Programmable Modulus (MOD) and Fractional (FRAC) Values

Unlike most other fractional-N PLLs, the AD9577 allows users to program the modulus over a 12-bit range, which means they can set up the part in many different configurations. It also usually means that, in most applications, it is possible to design the PLL to achieve the desired output frequency multiplication with 0 ppm frequency error. The MOD value is set by setting Register BF1[3:0] and Register BF2[7:0]. The FRAC value is set by setting Register BF0[7:0] and Register BF1[7:4].

### Bleed Current

When the SDM is operational (Register ABF0[4] set to 0), bleed current should be enabled (Register BP0[2] set to 1), which increases the in-band phase noise but reduces the fractional spur amplitudes. All fractional-N jitter data is reported with bleed = 1. If bleed = 0 in fractional-N mode, the rms jitter decreases significantly; however, the fractional spur amplitudes increase. When PLL2 operates in integer-N mode, the bleed current should be disabled to improve the PLLs in-band phase noise.

### SPUR MECHANISMS

This section describes the three different spur mechanisms that arise with a fractional-N PLL: fractional spurs, integer boundary spurs, and reference spurs.

### Fractional Spurs

The fractional interpolator in the AD9577 is a third-order SDM with a modulus that is programmable to any integer value from 50 to 4095. The SDM is clocked at the PFD reference rate ( $f_{PFD}$ ) that allows PLL output frequencies to be synthesized at a channel step resolution of  $f_{PFD}/MOD$ . The quantization noise from the  $\Sigma$ - $\Delta$  modulator appears as fractional spurs. The interval between spurs is  $f_{PFD}/L$ , where L is the repeat length of the code sequence in the digital  $\Sigma$ - $\Delta$  modulator. For the third-order modulator used in the AD9577, the repeat length depends on the value of MOD, as listed in Table 23.

**Table 23. Fractional Spur Frequencies**

Condition	Repeat Length	Spur Interval
If MOD is divisible by 2, but not 3	$2 \times MOD$	$f_{PFD}/(2 \times MOD)$
If MOD is divisible by 3, but not 2	$3 \times MOD$	$f_{PFD}/(3 \times MOD)$
If MOD is divisible by 6	$6 \times MOD$	$f_{PFD}/(6 \times MOD)$
Otherwise	MOD	$f_{PFD}/MOD$

### Integer Boundary Spurs

Another mechanism for fractional spur creation is the interactions between the RF VCO frequency and the reference frequency. When these frequencies are not integer related (the point of a fractional-N synthesizer), spur sidebands appear on the VCO output spectrum at an offset frequency that corresponds to the beat note or difference frequency, between an integer multiple of the reference and the VCO frequency. These spurs are attenuated by the loop filter and are more noticeable on channels close to integer multiples of the reference where the difference frequency can be inside the loop bandwidth; therefore, the name integer boundary spurs.

### Reference Spurs

Reference spurs occur for both integer-N and fractional-N operation. Reference spurs are generally not a problem in fractional-N synthesizers because the reference offset is far outside the loop bandwidth. However, any reference feed-through mechanism that bypasses the loop may cause a problem. Feedthrough of low levels of on-chip reference switching noise, through the reference input or output pins back to the VCO, can result in noticeable reference spur levels. In addition, coupling of the reference frequency to the output clocks can result in beat note spurs. PCB layout needs to ensure adequate isolation between VCO/LDO supplies, the output traces, and the input or output reference to avoid a possible feedthrough path on the board. If the reference output clock (REFCLK) is not required, it should be powered down to minimize potential board coupling. The SDM digital circuitry is clocked by the reference clock. The SDM is enabled when PLL2 is in fractional-N mode. When PLL2 is in fractional-N mode, the switching noise at the reference frequency may result in increased spurs levels at the outputs.

### OPTIMIZING PLL PERFORMANCE

Because the AD9577 can be configured in many ways, some guidelines should be followed to ensure that the high performance is maintained. For both PLLs, there can be a small advantage in choosing a lower VCO frequency because the VCO phase noise tends to be slightly better at lower frequencies. Both VCOs should not operate at the same frequency because this degrades jitter performance. The two VCO frequencies should differ by at least 2 MHz. The following guidelines apply to PLL2 operating in fractional-N mode only. If possible, denominators that have factors of 2, 3, or 6 should be avoided because they can produce slightly higher subfractional spur components. Avoid low and high fractions (that is,  $\text{FRAC}/\text{MOD}$  close to  $1/\text{MOD}$  or  $(\text{MOD} - 1)/\text{MOD}$ ) because these are more susceptible to larger fractional spur components and integer boundary spurs. Avoid creating a low valued beat frequency between the output frequency and the PFD frequency to minimize the risk of low offset beat frequency spurs. For example, setting  $f_{\text{PFD}} = 25$  MHz, and  $f_{\text{OUT}} = 100.01$  MHz can create an output spur at 10 kHz offset to 100.01 MHz, depending on board layout. Choosing a smaller MOD value results in fractional spurs that are at a higher frequency and, consequently, are better filtered by the PLL loop filter bandwidth of 50 kHz.

### SETTING THE OUTPUT FREQUENCY OF PLL2

For example, to set the output frequency ( $f_{\text{OUT}2}$ ) on Port 2 to 155.52 MHz and the output frequency ( $f_{\text{OUT}3}$ ) on Port 3 to 38.88 MHz using a reference frequency ( $f_{\text{REF}}$ ) and PFD frequency ( $f_{\text{PFD}}$ ) of 25 MHz, do the following.

The frequency  $f_{\text{OUT}2}$  presented to OUT2 can be set according to Equation 10.

The frequency  $f_{\text{OUT}3}$  presented to OUT3 can be set according to Equation 11.

In this case, both 155.52 MHz and 38.88 MHz can be derived from the same VCO frequency because they are related by a factor of 4.

The next step is to determine what the required values of  $f_{\text{VCO}2}$ ,  $V2$ , and  $D2$  are to divide down to 155.52 MHz. Table 24 shows the available options.

**Table 24. Suitable Values of  $f_{\text{VCO}2}$  and  $V2 \times D2$ , to Achieve  $f_{\text{OUT}2} = 155.52$  MHz**

$f_{\text{OUT}2}$ (MHz)	$V2 \times D2$	$f_{\text{VCO}2}$ (GHz)
155.52	14	2.17728
155.52	15	2.3328
155.52	16	2.48832

Choose a  $f_{\text{VCO}2}$  value of 2.48832 GHz. Next, determine that the multiplication ratio ( $Nb + \text{FRAC}/\text{MOD}$ ) required to multiply a  $f_{\text{PFD}}$  of 25 MHz up to 2.48832 GHz is 99.5328. Therefore,  $Nb$  must be set to 99 and  $(\text{FRAC}/\text{MOD}) = 0.5328$ . To convert 0.5328 to a fraction, 0.5328 can be the same as 5328/10000. This fraction can then be reduced to the lowest terms by dividing both the numerator and denominator by 16, where 16 is the greatest common divisor (GCD) of the 5328 and 10,000. This results in a solution for  $\text{FRAC}/\text{MOD} = 333/625$ .

For 155.52 MHz on Port 2, set  $V2 \times D2 = 16$ . This can be achieved by setting  $V2$  to 4 and  $D2$  to 4. For 38.88 MHz on Port 3, set  $V3 \times D3 = 64$ . This can be achieved by setting  $V3$  to 4 and  $D3$  to 16. With a reference frequency of 25 MHz, the reference divider value,  $R$ , must be set to 1 by setting Register  $G0[1]$  to 0. Because both channels use VCO divide values of 4 on  $V2$  and  $V3$ , SyncCh23, Register  $\text{BDV}2[0]$ , can be set to 1 to ensure that the clock edges on Port 2 and Port 3 are synchronized. Table 25 summarizes the register setting for this configuration.

**Table 25. Registers Setting for Example PLL2 Configuration**

Parameter	Value	I <sup>2</sup> C Register	Register Value
$Nb$	99	BF3[5:0]	010011
FRAC	333	BF0[7:0], BF1[7:4]	000101001101
MOD	625	BF1[3:0], BF2[7:0]	001001110001
$V2$	4	BDV0[7:5]	100
$D2$	4	BDV0[4:0]	00100
$V3$	4	BDV1[7:5]	100
$D3$	16	BDV1[4:0]	10000
$R$	1	$G0[1]$	0000
SyncCh23	1	BDV2[0]	1

**MARGINING**

By asserting the MARGIN pin, a second full frequency map can be applied to the output ports. The values for the Na, V0, D0, V1, and D1 parameters, and the Nb, FRAC, MOD, V2, D2, V3, D3 parameters must be programmed over the I<sup>2</sup>C, although default values exist. There are some limitations: the output buffer signal formats cannot be changed, and the PLL2 fractional-N settings, such as power-down of the SDM, and bleed settings cannot be changed. The margining feature can be used to set higher than nominal frequencies on each of the ports to test system robustness.

When the MARGIN pin signal level is changed, a new frequency acquisition is performed.

**SPREAD SPECTRUM CLOCK GENERATION (SSCG)**

By asserting the SSCG (spread spectrum clock generator) pin, PLL2 operates in spread spectrum mode, and the output frequency modulates with a triangular profile. As the clock signal energy spreads out over a range of frequencies, it reduces the peak power at any one frequency when observed with a spectrum analyzer through a resolution bandwidth filter. This result improves the radiated emissions from the part and from the devices that receive its clock.

The triangular-wave modulation is implemented by controlling the divide ratio of the feedback divider. This is achieved by ramping the fractional word to the SDM. Figure 43 shows an example implementation. The PFD frequency,  $f_{PFD}$ , is 25 MHz. The starting VCO frequency,  $f_{VCO}$ , is  $25 \text{ MHz} \times (99 + 3072/4096)$ , giving 2.49375 GHz. By continuously ramping the FRAC word down and up, this frequency is periodically reduced to  $25 \text{ MHz} \times (99 + 1029/4096) = 2.481281 \text{ GHz}$ . This results in a triangular frequency modulation profile, with a peak downspread (that is, peak percentage frequency reduction) of  $-0.5\%$ . By controlling the step size, number of steps, and the step rate, the modulation frequency is adjusted.

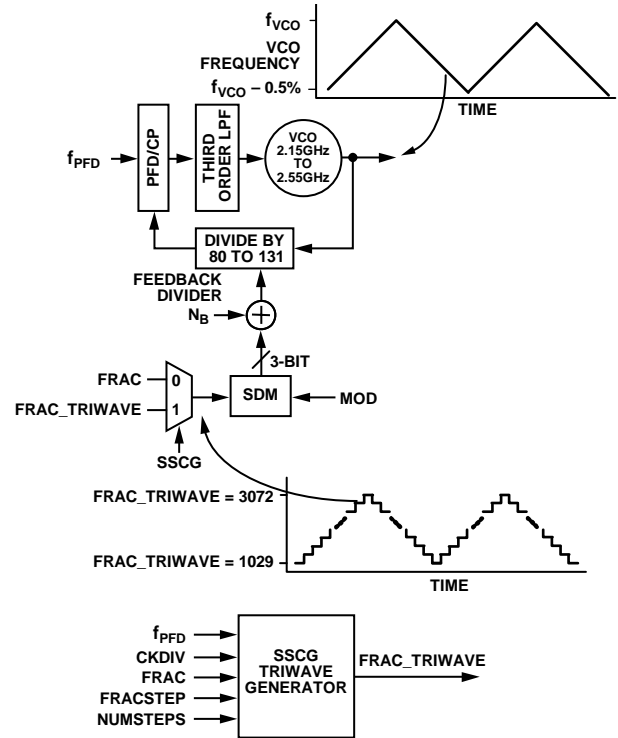

Figure 43. Spread Spectrum Clock Generator with Triangular Wave Modulation,  $f_{PFD} = 25 \text{ MHz}$

**Basic Spread Spectrum Programming**

The SSCG is highly programmable; however, most applications require that the frequency modulation rate be between 30 kHz and 33 kHz and that the peak frequency deviation be  $-0.5\%$  downspread. The AD9577 supports downspread only, with a maximum deviation of  $-0.5\%$ .

The key parameters (which are not themselves registers) that define the frequency modulation profile include the following:

- $f_{MOD}$ , which is the frequency of the modulation waveform.
- FracRange, which determines the peak frequency deviation by setting the maximum change in the FRAC value from the nominal.

The following equations determine the value of these parameters:

$$FracRange = FracStep \times NumSteps \tag{12}$$

$$f_{MOD} = \frac{f_{PFD}}{2 \times NumSteps \times CkDiv} \tag{13}$$

where the following are programmable registers:

- NumSteps is the number of fractional word steps in half the triwave period.
- FracStep is the value of the fractional word increment/decrement, while traversing the tri-wave.
- CkDiv is the integer value by which the reference clock frequency is divided to determine the update rate of the triangular-wave generator, that is, the step update rate.
- $f_{PFD}$  is the PFD frequency.

Table 26 shows the relevant register names and programmable ranges.

**Table 26. Registers Used to Program SSCG Operation**

Parameter	Register Name	Range
NumSteps	BS2[7:0], BS3[7]	+1 to +511
FracStep	BS1[7:0]	-128 to 0
CkDiv	BS3[6:0]	+2 to +127

Because the register values need to be expressed as integers, there are no guaranteed exact solutions; therefore, some approximations and trade-offs must be made. The fact that neither FracRange nor  $f_{MOD}$  needs to be exact is exploited.

Note that the SSCG pin must be toggled every time the SSCG parameters are adjusted for the changes to take effect.

**Worked Example: Programming for  $f_{MOD} = 31.25$  kHz, Downsplayed = -0.5%,  $f_{PFD} = 25$  MHz**

Assume  $Nb = 100$ ,  $MOD = 625$ , and  $FRAC = 198$ . In addition, a large number of frequency steps are desired to cover -0.5%. The objective is to find values for FracStep, NumSteps, and CkDiv that result in the required frequency modulation profile.

The total feedback divider ratio is

$$N_{TOT} = Nb + \frac{FRAC}{MOD} = 100 + 198/625 = 62,698/625$$

FracRange is set to -0.5% of 62,698, which results in an ideal value of -313.5.

By rearranging Equation 12 and Equation 13, it results in

$$FracStep = CkDiv \times \left( \frac{2 \times FracRange \times f_{MOD}}{f_{PFD}} \right) \quad (14)$$

Putting in the values for FracRange,  $f_{MOD}$ , and  $f_{PFD}$  from the previous information, the following results:

$$FracStep = CkDiv \times (-0.78375) \quad (15)$$

An approximate solution must be found to Equation 15 that produces an integer value for CkDiv, which gives a value that is very close to an integer for FracStep. In this case, considering CkDiv values in the range of 2 to 10 gives the FracStep values shown in Table 27.

**Table 27. CkDiv and FracStep Values Used in Worked Example**

CkDiv	Ideal FracStep	Rounded FracStep	FracStep Error
2	-1.5675	-2	21.6%
3	-2.35125	-2	17.6%
4	-3.135	-3	4.5%
5	-3.91875	-4	2.0%
6	-4.7025	-5	6.0%
7	-5.48625	-5	9.7%
8	-6.27	-6	4.5%
9	-7.05375	-7	0.77%
10	-7.8375	-8	2.0%

Both CkDiv and NumSteps must be integers. To minimize error, CkDiv = 9 and FracStep = -7 was chosen. With a target for FracRange = -313.5, Equation 12 is used to find the ideal value of NumSteps = 44.79, which is rounded to 45. From Equation 12, the actual used value for FracRange is

$$FracRange = -7 \times 45 = -315$$

The accuracy of this solution needs to be verified. Putting the derived values into Equation 13 gives

$$f_{MOD} = \frac{f_{PFD}}{2 \times NumSteps \times CkDiv} = \frac{25 \text{ MHz}}{2 \times 45 \times 9} = 30.86 \text{ kHz}$$

In addition, the percentage frequency deviation is obtained as

$$\begin{aligned} FrequencyDeviation &= \frac{100 \times FracRange}{MOD \times N_{TOT}} \\ &= \frac{100 \times -315}{625 \times \frac{62698}{625}} = -0.502\% \end{aligned}$$

The  $f_{MOD}$  and the percentage frequency deviation are very close to the target values. The register settings required for this example are detailed in Table 29.

**SSCG Register Summary**

Table 28 summarizes the programmable registers required to set up SSCG.

**Table 28. Register Values for SSCG**

Parameter	Register Names	Range
NumSteps	BS2[7:0], BS3[7]	+1 to +511
FracStep	BS1[7:0]	-128 to 0
CkDiv	BS3[6:0]	+2 to +127
FRAC	BF0[7:0], BF1[7:4]	0 to +4094
MOD	BF1[3:0], BF2[7:0]	0 to +4095
Nb	BF3[5:0]	0 to +51

**MAX\_BW**

The normal bandwidth of PLL2 is 50 kHz. This low bandwidth is required to filter the SDM phase noise. When SSCG is activated, the bandwidth is increased to 125 kHz. There is a trade-off in setting the PLL bandwidth between allowing the triangular-wave modulation (that is, its higher order harmonics) to pass through the PLL unattenuated and passing more SDM phase noise through to the PLL output. Bringing the MAX\_BW pin high changes the

PLL bandwidth to 250 kHz from its default value of 125 kHz during SSCG operation. Increasing the PLL bandwidth results in more SDM phase noise being passed unfiltered through to the PLL output, but more of the triangular-wave harmonics are also passed through, improving the triangular-wave accuracy.

**Table 29. Register Values for SSCG Example**

Parameter	Register Name	Range	Value (Decimal)	Value(Binary)
NumSteps	BS2[7:0], BS3[7]	+1 to +511	+45	00101101
FracStep	BS1[7:0]	-128 to 0	-7	11111001
CkDiv	BS3[6:0]	+2 to +127	+9	0001001
FRAC	BF0[7:0], BF1[7:4]	0 to +4094	+198	000011000110
MOD	BF1[3:0], BF2[7:0]	0 to +4095	+625	001001110001
Nb	BF3[5:0]	0 to +63	80 + 20 = 100	010100

# I<sup>2</sup>C INTERFACE TIMING AND INTERNAL REGISTER DESCRIPTION

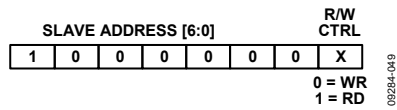

Figure 44. Slave Address Configuration

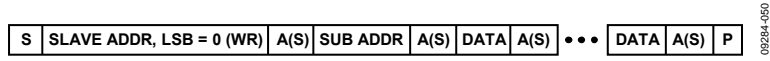

Figure 45. I<sup>2</sup>C Write Data Transfer

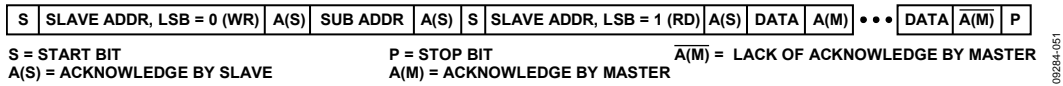

Figure 46. I<sup>2</sup>C Read Data Transfer

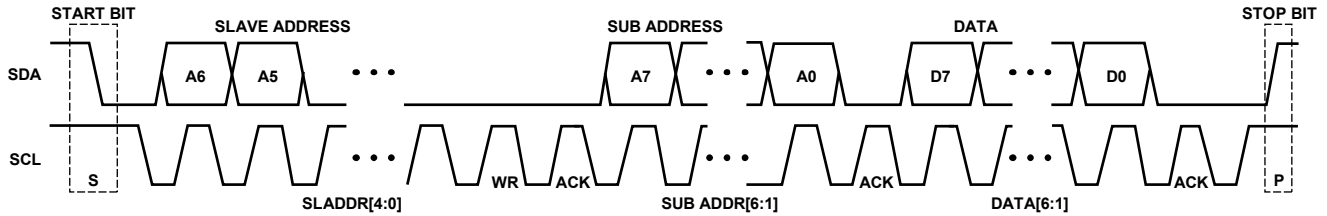

Figure 47. I<sup>2</sup>C Data Transfer Timing

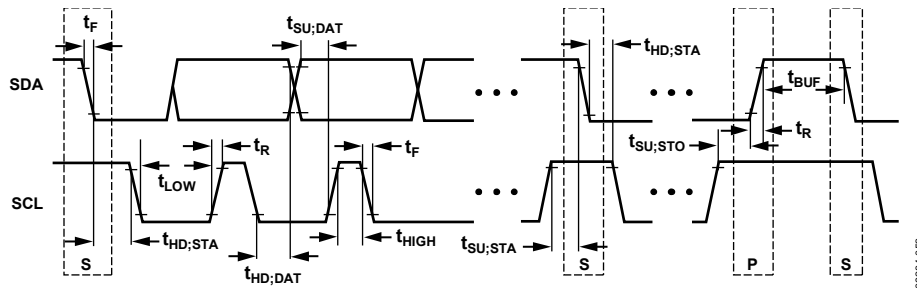

Figure 48. I<sup>2</sup>C Port Timing Diagram

Table 30. Internal Register Map

Register Name	R/W	Addr	D7	D6	D5	D4	D3	D2	D1	D0	
C0	W	0x40	0	0	0	0	0	0	EnI2C	0	
X0	W	0x1F	0	0	0	0	0	0	0	NewAcq	
BP0	W	0x11	0	0	0	0	0	Bleed	PDCH1	PDCH0	
AF0	W	0x18	0	0	Na[5:0], PLL1 feedback divider ratio						
BF3	W	0x1C	0	0	Nb[5:0], PLL2 feedback divider ratio						
BF0	W	0x19	FRAC[11:4], SDM fractional word								
BF1	W	0x1A	FRAC[3:0], SDM fractional word				MOD[11:8], SDM modulus				
BF2	W	0x1B	MOD[7:0], SDM modulus								
ABF0	W	0x1D	1	1	0	PD_SDM	0	0	0	0	
ADV0	W	0x22	V0[2:0], Channel 0 VCO divider			D0[4:0], Channel 0 output divider value					
ADV1	W	0x23	V1[2:0], Channel 1 VCO divider			D1[4:0], Channel 1 output divider value					
ADV2	W	0x24	0	0	0	0	0	0	0	SyncCh01	
BDV0	W	0x25	V2[2:0], Channel 2 VCO divider			D2[4:0], Channel 2 output divider value					
BDV1	W	0x26	V3[2:0], Channel 3 VCO divider			D3[4:0], Channel 3 output divider value					
BDV2	W	0x27	0	0	0	0	0	0	0	SyncCh23	
BS1	W	0x2A	FracStep[7:0], SSCG fractional step size								
BS2	W	0x2B	NumSteps[8:1], number of fractional word increments/decrements per half triangular-wave cycle								
BS3	W	0x2C	NumSteps[0]	CkDiv[6:0], reference divider output is divided by this integer to determine SSCG update rate							
AM0	W	0x30	0	0	Na[5:0], PLL1 feedback divider ratio divider; MARGIN = 1						
AM1	W	0x31	V0[2:0], Channel 0 VCO divider; MARGIN = 1			D0[4:0], Channel 0 output divider value; MARGIN = 1					
AM2	W	0x32	V1[2:0], Channel 1 VCO divider; MARGIN = 1			D1[4:0], Channel 1 output divider value; MARGIN = 1					
BM0	W	0x33	0	0	Nb[5:0], PLL2 feedback divider ratio divider; MARGIN = 1						
BM1	W	0x34	FRAC[11:4], SDM fractional word; MARGIN = 1								
BM2	W	0x35	FRAC[3:0], SDM fractional word; MARGIN = 1				MOD[11:8], SDM modulus; MARGIN = 1				
BM3	W	0x36	MOD[7:0], SDM modulus; MARGIN = 1								
BM4	W	0x37	V3[2:0], Channel 3 VCO divider; MARGIN = 1			D3[4:0], Channel 3 output divider value; MARGIN = 1					
BM5	W	0x38	V2[2:0], Channel 2 VCO divider; MARGIN = 1			D2[4:0], Channel 2 output divider value; MARGIN = 1					
DR1	W	0x3A	PDCH3	PDCH2	FORMAT2[2:0], output format selection for PLL2 (see Table 21)			FORMAT1[2:0], output format selection for PLL1 (see Table 20)			
DR2	W	0x3B	0	0	0	0	0	0	0	PDRefOut	
G0	W	0x3D	0	0	0	0	PDPLL1, power-down PLL1	PDPLL2, power-down PLL2	R; 0 = divide by 1	0	

## DEFAULT FREQUENCY MAP AND OUTPUT FORMATS

The power-up operation (without I<sup>2</sup>C programming) of the AD9577 is represented by a default frequency map and output formats (see Table 31).

Table 31. Default Parameter Values,  $f_{\text{PFD}} = 25 \text{ MHz}$

Parameter	Value	Notes
PLL1		$f_{\text{OUT0}} = 156.25 \text{ MHz}$ , $f_{\text{OUT1}} = 125 \text{ MHz}$
Na	$80 + 20 = 100$	
V0	4	
D0	4	
V1	4	
D1	5	
FORMAT1	000	OUT0/OUT1 are LVPECL
SyncCh01	0	
PLL2		$f_{\text{OUT2}} = 100 \text{ MHz}$ , $f_{\text{OUT3}} = 33.333 \text{ MHz}$
Nb	$80 + 16 = 96$	
FRAC	0	
MOD	0	
PD_SDM	1	
Bleed	0	
V2	4	
D2	6	
V3	4	
D3	18	
FORMAT2	000	OUT2/OUT3 are LVPECL
SyncCh23	0	
SSCG		
FracStep	0	
NumSteps	0	
CkDiv	0	
Control		
EnI2C	0	
NewAcq	0	
PDCH0	0	
PDCH1	0	
PDCH2	0	
PDCH3	0	
PDRefOut	0	
PDPLL1	0	
PDPLL2	0	
R	0	

Parameter	Value	Notes
Margining		These parameters are applied only when the MARGIN pin = high $f_{\text{OUT0}} = 156.25 \text{ MHz}$ , $f_{\text{OUT1}} = 125 \text{ MHz}$
PLL1		
Na	$80 + 20 = 100$	
V0	4	
D0	4	
V1	4	
D1	5	
$f_{\text{OUT0}}$	156.25 MHz	
$f_{\text{OUT1}}$	125 MHz	
PLL2		$f_{\text{OUT2}} = 212.5 \text{ MHz}$ , $f_{\text{OUT3}} = 106.25 \text{ MHz}$
Nb	$80 + 22 = 102$	
FRAC	0	
MOD	0	
V2	2	
D2	6	
V3	4	
D3	6	

## I<sup>2</sup>C INTERFACE OPERATION

The AD9577 is programmed by a 2-wire, I<sup>2</sup>C-compatible serial bus driving multiple peripherals. Two inputs, serial data (SDA) and serial clock (SCL), carry information between any devices connected to the bus. Each slave device is recognized by a unique address. The slave address consists of the 7 MSBs of an 8-bit word. The 7-bit slave address of the AD9577 is 1000000. The LSB of the word sets either a read or write operation (see Figure 44). Logic 1 corresponds to a read operation, and Logic 0 corresponds to a write operation.

To control the device on the bus, do the following protocol. First, the master initiates a data transfer by establishing a start condition, defined by a high-to-low transition on SDA while SCL remains high, which indicates that an address/data stream follows. All peripherals respond to the start condition and shift the next eight bits (the 7-bit address and the R/W bit). The bits are transferred from MSB to LSB. The peripheral that recognizes the transmitted address responds by pulling the data line low during the ninth clock pulse, which is known as the acknowledge bit. All other devices withdraw from the bus at this point and maintain an idle condition. The idle condition is where the device monitors the SDA and SCL lines waiting for the start condition and correct transmitted address. The R/W bit determines the direction of the data. Logic 0 on the LSB of the first byte means that the master writes information to the peripheral, and Logic 1 on the LSB of the first byte means that the master reads information from the peripheral.

The AD9577 acts as a standard slave device on the bus. The data on the SDA pin is eight bits long supporting the 7-bit addresses plus the R/W bit. The AD9577 has 31 subaddresses to enable the user-accessible internal registers (see Table 30). Therefore, it interprets the first byte as the device address and the second byte as the starting subaddress. Auto-increment mode is supported, which allows data to be read from or written to the starting subaddress and each subsequent address without manually addressing the subsequent subaddress. A data transfer is always terminated by a stop condition. The user can also access any unique subaddress register on a one-by-one basis without updating all registers.

Stop and start conditions can be detected at any stage of the data transfer. If these conditions are asserted out of sequence with normal read and write operations, they cause an immediate jump to the idle condition. During a given SCL high period, one start condition, one stop condition, or a single stop condition followed by a single start condition should be issued. If an invalid subaddress is issued, the AD9577 does not issue an acknowledge and returns to the idle condition. If the highest subaddress is exceeded while reading back in auto-increment mode, the highest subaddress register contents continue to be output until the master device issues a no acknowledge, which indicates the end of a read. In a no acknowledge condition, the SDA line is not pulled low on the ninth pulse. See Figure 45 and Figure 46 for sample read and write data transfers, and see Figure 47 for a more detailed timing diagram.

To overwrite any of the default register values, complete the following steps:

1. Enable the overwriting of registers by setting EnI2C, Register C0[1].
2. Only write to registers that need modification from their default value.
3. After all the registers have been set, a new acquisition is initiated by toggling NewAcq, Register X0[0] from low to high to low.

An example set of I<sup>2</sup>C commands follows. These enable the I<sup>2</sup>C registers and program the output frequencies of both PLLs.  $f_{\text{PFD}}$  is 25 MHz. A leading W represents a write command.

**Table 32. I<sup>2</sup>C Programming Example Register Writes**

Write/Read	Register Name	Data (Hex)	Operation
W	C0	02	Enable I <sup>2</sup> C registers
W	AF0	0A	$N_a = 80 + 10 = 90$ ; $f_{\text{VCO1}} = 2.25 \text{ GHz}$
W	ADV0	A6	Channel 0 divides by $5 \times 6 = 30$ ; $f_{\text{OUT0}} = 75 \text{ MHz}$
W	ADV1	CC	Channel 1 divides by $6 \times 12 = 72$ ; $f_{\text{OUT1}} = 31.25 \text{ MHz}$
W	BF3	15	$N_b = 80 + 21 = 101$ ; $F_{\text{VCO2}} = 2.53832 \text{ GHz}$
W	BF0	14	FRAC = 333
W	BF1	D2	FRAC = 333, MOD = 625
W	BF2	71	MOD = 625
W	ABF0	C0	Power-up SDM, release SDM reset
W	BP0	04	Turn on Bleed
W	BDV0	44	Channel 2 divides by $2 \times 4 = 8$ ; $f_{\text{OUT2}} = 317.29 \text{ MHz}$
W	BDV1	B0	Channel 3 divides by $5 \times 16 = 80$ ; $f_{\text{OUT3}} = 31.729 \text{ MHz}$
W	X0	01	Force new acquisition by toggling NewAcq
W	X0	00	

TYPICAL APPLICATION CIRCUITS

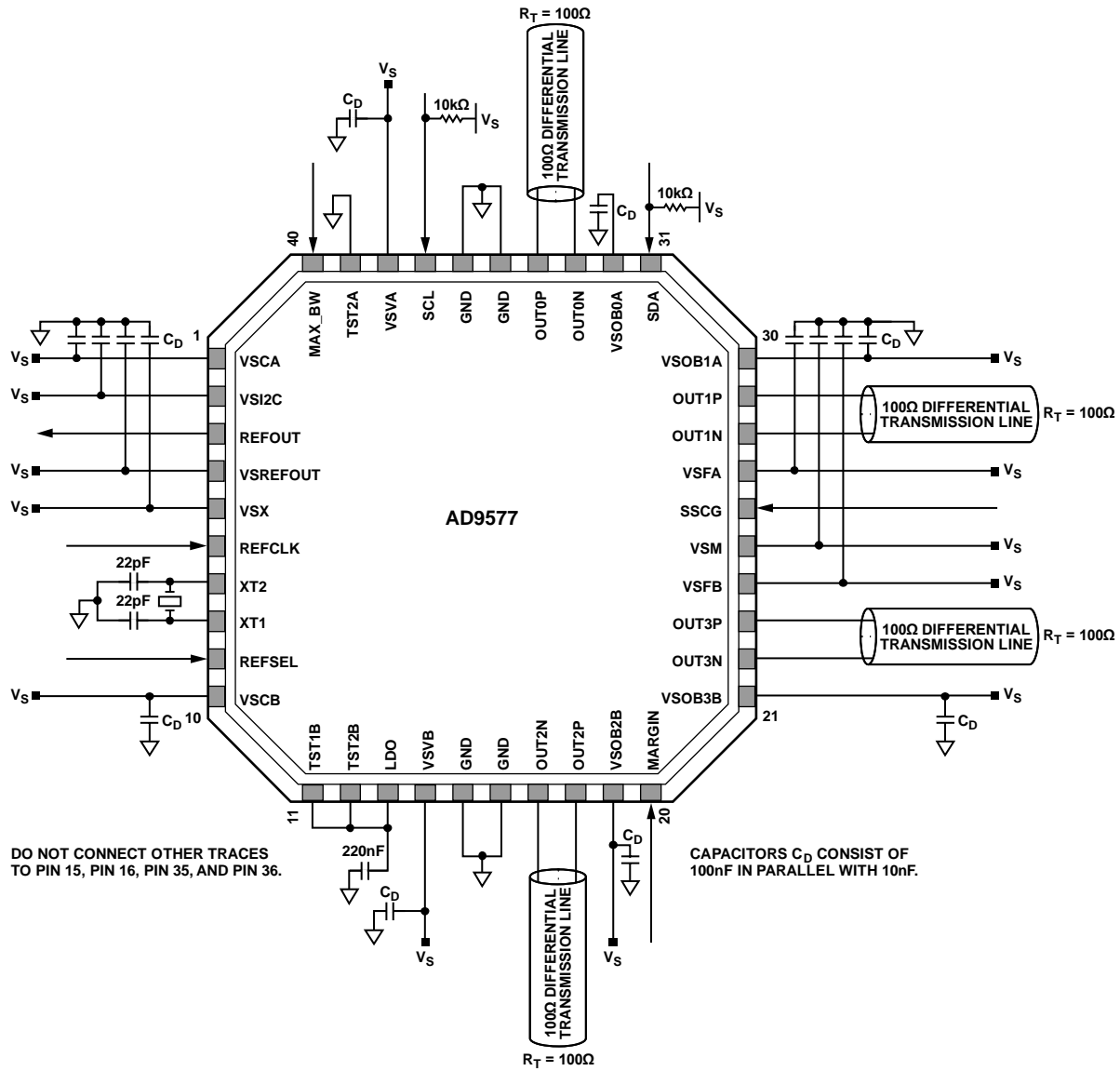
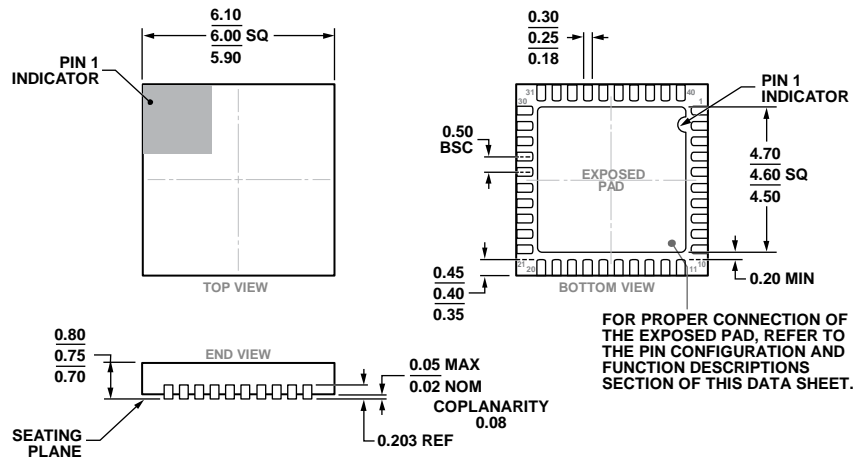

Figure 49. Typical LVDS Application Circuit

09294-354



OUTLINE DIMENSIONS



COMPLIANT TO JEDEC STANDARDS MO-220-WJJD-5

Figure 51. 40-Lead Lead Frame Chip Scale Package [LFCSP\_WQ]  
 6 mm × 6 mm Body, Very Very Thin Quad  
 (CP-40-7)  
 Dimensions shown in millimeters

ORDERING GUIDE

Model <sup>1</sup>	Temperature Range	Package Description	Package Option	Ordering Quantity
AD9577BCPZ	-40°C to +85°C	40-Lead LFCSP_WQ	CP-40-7	
AD9577BCPZ-RL	-40°C to +85°C	40-Lead LFCSP_WQ, 13" Tape Reel	CP-40-7	2,500
AD9577BCPZ-R7	-40°C to +85°C	40-Lead LFCSP_WQ, 7" Tape Reel	CP-40-7	750
AD9577-EVALZ		Evaluation Board		

<sup>1</sup> Z = RoHS Compliant Part.

<sup>12</sup>C refers to a communications protocol originally developed by Philips Semiconductors (now NXP Semiconductors).

## Looking for pricing, stock, or lifecycle information?

Click below to explore more details on WIN SOURCE:

 [View AD9577BCPZ-R7 on WIN SOURCE](#)

 [Analog Devices Inc. Information](#)

## Optimize Your Supply Chain with WIN SOURCE Solutions

-  Global Sourcing Solution
-  Obsolete Management
-  Cost Control Management
-  Shortage Management
-  Alternative Solution
-  Excess Inventory Management