



**THE DATASHEET OF
ZL30363GDG2**



Features

- Two independent clock channels
- Frequency and Phase Sync over Packet Networks
 - Frequency accuracy performance for WCDMA-FDD, GSM, LTE-FDD and femtocell applications
 - Frequency performance for ITU-T G.823 and G.824 synchronization interface, as well as G.8261 PNT PEC and CES interfaces
 - Phase Synchronization performance for WCDMA-TDD, Mobile WiMAX, TD-SCDMA and CDMA2000 applications
 - Client holdover and reference switching between multiple Servers
- Physical Layer Equipment Clocks Synchronization
 - ITU-T G.8262 for SyncE EEC option 1 and 2
 - ITU-T G.813 for SONET/SDH SEC option 1 and 2
 - Telcordia GR-1244 and GR-253 Stratum 3 and SMC
 - Support for G.781 SETS

Ordering Information:

ZL30363GDG2 144 Pin LPGA Trays^Á

Pb Free Tin/Silver/Copper
-40°C to +85°C
 Package size: 13 x 13 mm

- Any input clock rate from 1 Hz to 750 MHz
- Automatic hitless reference switching and digital holdover on reference fail
- Flexible two-stage architecture to support conversion between SONET/SDH and OTN rates
- Digital PLLs with programmable bandwidth from 0.1 mHz up to 1 kHz
- Programmable synthesizers
 - Any output clock rate from 1 Hz to 750 MHz with maximum jitter below 0.63 ps RMS
- Operates from a single crystal resonator or clock oscillator
- Configurable via SPI/I²C interface

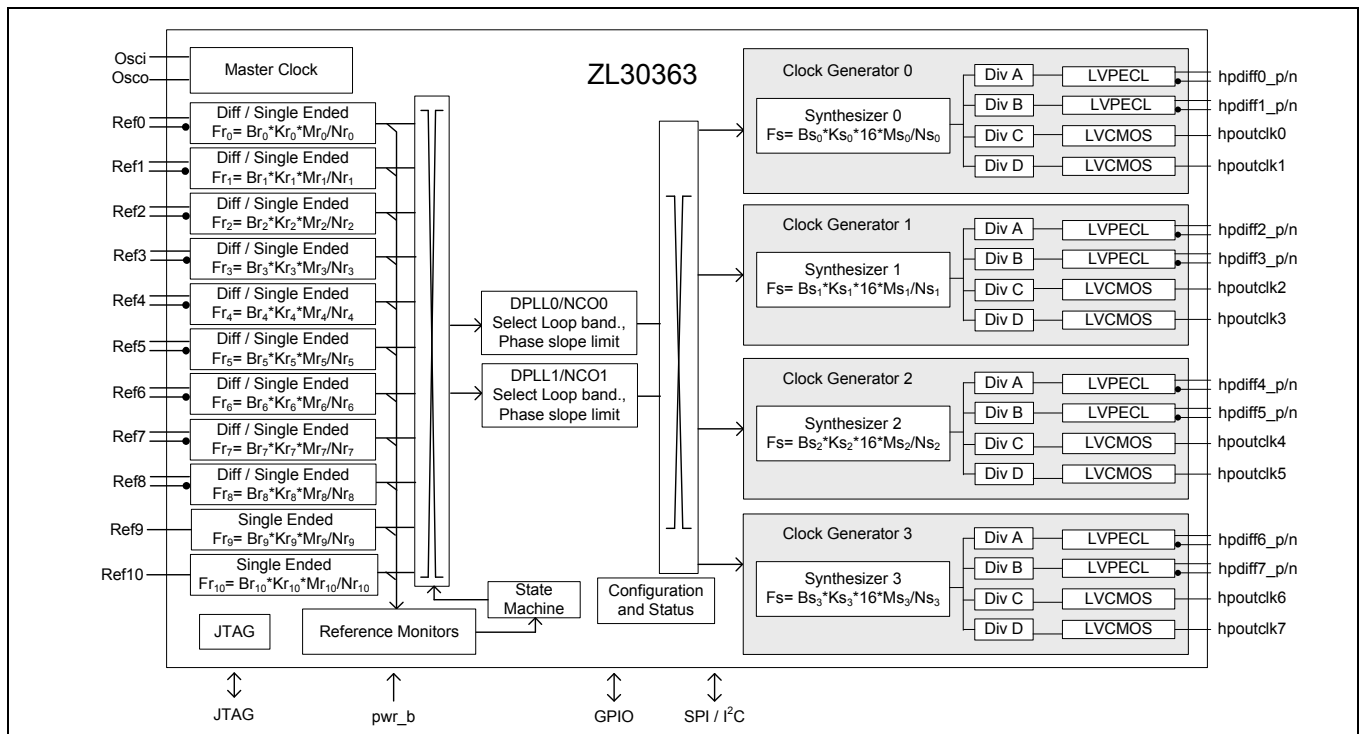

Figure 1 - Functional Block Diagram

Detailed Features

General

- Two independent clock channels
- Operates from a single crystal resonator or clock oscillator
- Configurable via its SPI/I²C interface

Time Synchronization Algorithm

- External algorithm controls software digital PLL to adjust frequency and phase alignment
- Frequency, Phase and Time Synchronization over IP, MPLS and Ethernet Packet Networks
- Frequency accuracy performance for WCDMA-FDD, GSM, LTE-FDD and femtocell applications, with target performance less than ± 15 ppb.
- Frequency performance for ITU-T G.823 and G.824 synchronization interface, as well as G.8261 PNT EEC, PNT PEC and CES interface specifications.
- Phase Synchronization performance for WCDMA-TDD, Mobile WiMAX, TD-SCDMA and CDMA2000 applications with target performance less than ± 1 μ s phase alignment.
- Time Synchronization for UTC-traceability and GPS replacement.
- Client reference switching between multiple Servers
- Client holdover when Server packet connectivity is lost

Electrical Clock Inputs

- Nine input references configurable as single ended or differential and two single ended input references
- Synchronize to any clock rate from 1 Hz to 750 MHz on differential inputs
- Synchronize to any clock rate from 1 Hz to 177.75 MHz on singled-ended inputs
- Any input reference can be fed with sync (frame pulse) or clock.
- Synchronize to sync pulse and sync pulse/clock pair.
- Flexible input reference monitoring automatically disqualifies references based on frequency and phase irregularities
 - LOS
 - Single cycle monitor
 - Precise frequency monitor
 - Coarse frequency monitor
 - Guard soak timer
- Per input clock delay compensation

Electrical Clock Engine

- Digital PLLs filter jitter from 0.1 mHz up to 1 kHz
- Flexible two-stage architecture translates between arbitrary data rates, line coding rates and FEC rates
- Internal state machine automatically controls mode of operation (free-run, locked, holdover)
- Automatic hitless reference switching and digital holdover on reference fail
 - Physical-to-physical reference switching

- Physical-to-packet reference switching
- Packet-to-physical reference switching
- Packet-to-packet reference switching
- Support for wide variety of Equipment Clock specifications
 - SyncE
 - ITU-T G.8262 option 1 EEC (Europe/China)
 - ITU-T G.8262 option 2 (USA)
 - SONET/SDH
 - ITU-T G.813 option 1 SEC (Europe/China)
 - ITU-T G.813 option 2 (USA)
 - ANSI T1.105/Telcordia GR-253 Stratum 3 for SONET
 - Telcordia GR-253 SMC
 - PDH
 - ITU-T G.812 Type I SSU
 - ITU-T G.812 Type III, ANSI T1.101/Telcordia GR-1244 Stratum 3E, including phase build out
 - ANSI T1.101/Telcordia GR-1244 Stratum 3
 - ANSI T1.101/Telcordia GR-1244 Stratum 4E/4
- Selectable phase slope limiting
- Holdover better than 1 ppb (when using < 0.1 Hz filter)
- Supports ITU-T G.823, G.824 and G.8261 for 2048 kbit/s and 1544 kbit/s interfaces
- Supports G.781 SETS

Electrical Clock Generation

- Four programmable synthesizers
- Eight LVPECL outputs
 - Two LVPECL outputs per synthesizer
 - Generate any clock rate from 1 Hz to 750 MHz
 - Maximum jitter below 0.63 ps rms
 - Meets OC-192, STM-64, 1 GbE and 10 GbE interface jitter requirements
- Eight LVCMOS outputs
 - Two LVCMOS outputs per synthesizer
 - Generate any clock rate from 1 Hz to 177.75 MHz
- Programmable output advancement/delay to accommodate trace delays or compensate for system routing paths
- Outputs may be disabled to save power

API Software

- Interfaces to 1588-capable PHY and switches with integrated timestamping
- Abstraction layer for independence from OS and CPU, from embedded SoC to home-grown
- Fits into centralized, highly integrated pizza box architectures as well as distributed architectures with multiple line cards and timing cards

Applications

- ITU-T G.8262 System Timing Cards which support 1 GbE and 10 GbE interfaces
- Telcordia GR-253 Carrier Grade SONET/SDH Stratum 3 System Timing Cards
- System Timing Cards which supports ITU-T G.781 SETS (SDH Equipment Timing Source)
- Integrated basestation reference clock for air interface for GSM, WCDMA, LTE and WiMAX macro, micro, or femtocells
- Mobile Backhaul NID, edge router or access aggregation node
- EPON/GE-PON and GPON OLT
- EPON/GE-PON and GPON ONU/OLT
- DSLAM and RT-DSLAM
- 10 Gigabit line cards
- Synchronous Ethernet, 10 GBASE-R, and 10 GBASE-W
- SONET/SDH, Fibre Channel, XAUI

Information relating to products and services furnished herein by Microsemi Corporation or its subsidiaries (collectively "Microsemi") is believed to be reliable. However, Microsemi assumes no liability for errors that may appear in this publication, or for liability otherwise arising from the application or use of any such information, product or service or for any infringement of patents or other intellectual property rights owned by third parties which may result from such application or use. Neither the supply of such information or purchase of product or service conveys any license, either express or implied, under patents or other intellectual property rights owned by Microsemi or licensed from third parties by Microsemi, whatsoever. Purchasers of products are also hereby notified that the use of product in certain ways or in combination with Microsemi, or non-Microsemi furnished goods or services may infringe patents or other intellectual property rights owned by Microsemi.

This publication is issued to provide information only and (unless agreed by Microsemi in writing) may not be used, applied or reproduced for any purpose nor form part of any order or contract nor to be regarded as a representation relating to the products or services concerned. The products, their specifications, services and other information appearing in this publication are subject to change by Microsemi without notice. No warranty or guarantee express or implied is made regarding the capability, performance or suitability of any product or service. Information concerning possible methods of use is provided as a guide only and does not constitute any guarantee that such methods of use will be satisfactory in a specific piece of equipment. It is the user's responsibility to fully determine the performance and suitability of any equipment using such information and to ensure that any publication or data used is up to date and has not been superseded. Manufacturing does not necessarily include testing of all functions or parameters. These products are not suitable for use in any medical and other products whose failure to perform may result in significant injury or death to the user. All products and materials are sold and services provided subject to Microsemi's conditions of sale which are available on request.

**For more information about all Microsemi products
visit our website at
www.microsemi.com/timing-and-synchronization**

TECHNICAL DOCUMENTATION – NOT FOR RESALE



Microsemi Corporate Headquarters
One Enterprise, Aliso Viejo CA 92656 USA
Within the USA: +1 (949) 380-6100
Sales: +1 (949) 380-6136
Fax: +1 (949) 215-4996

Microsemi Corporation (NASDAQ: MSCC) offers a comprehensive portfolio of semiconductor solutions for: aerospace, defense and security; enterprise and communications; and industrial and alternative energy markets. Products include high-performance, high-reliability analog and RF devices, mixed signal and RF integrated circuits, customizable SoCs, FPGAs, and complete subsystems. Microsemi is headquartered in Aliso Viejo, Calif. Learn more at www.microsemi.com.

© 2013 Microsemi Corporation. All rights reserved. Microsemi and the Microsemi logo are trademarks of Microsemi Corporation. All other trademarks and service marks are the property of their respective owners.

Looking for pricing, stock, or lifecycle information?

Click below to explore more details on WIN SOURCE:

 [View ZL30363GDG2 on WIN SOURCE](#)

 [Microsemi Corporation](#) Information

Optimize Your Supply Chain with WIN SOURCE Solutions

-  Global Sourcing Solution
-  Obsolete Management
-  Cost Control Management
-  Shortage Management
-  Alternative Solution
-  Excess Inventory Management