

General Description

The IDTVS512 is a bi-directional 5-Port 2:1 multiplexer/demultiplexer with Hi-Z outputs for both RGB and composite video switching applications. With the additional two ports, vertical and horizontal synchronous signals can be switched in addition to switching the RGB and composite signals between different components (DVDs, VCRs, PCs, etc.). The VideoSwitch can be driven from a current output RAMDAC or voltage output composite video source.

Low on-resistance, low crosstalk, low OFF isolation and wide bandwidth features make it ideal for video and other applications. The IDTVS512 offers a high-performance (600 MHz), low-cost solution to switch between video sources.

Features

- R_{ON} is 4Ω typical
- Bidirectional switch
- Low bit-to-bit skew: 200ps
- Low crosstalk: $-65dB$ @ 10MHz
- Near-Zero propagation delay: 250ps
- Fast switching speed: 9ns
- Channel On-Capacitance: 6pF (typical)
- 8KV ESD HBM on connector side
- Wide bandwidth (600 MHz)
- Available in QSOP package

Applications

- Projection TV and LCD TV
- Video consumer applications
- Analog video signal routing

Block Diagram

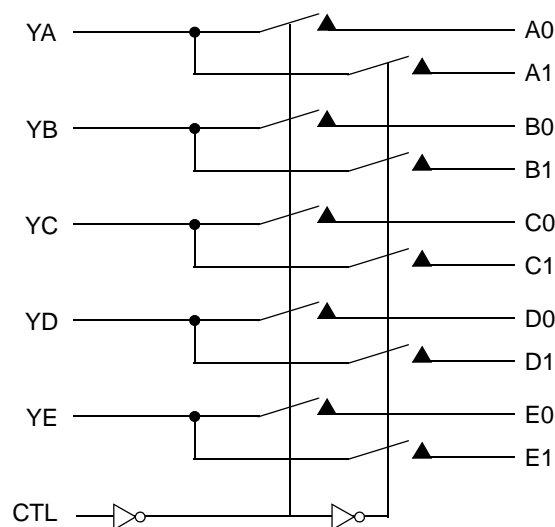

Pin Configuration

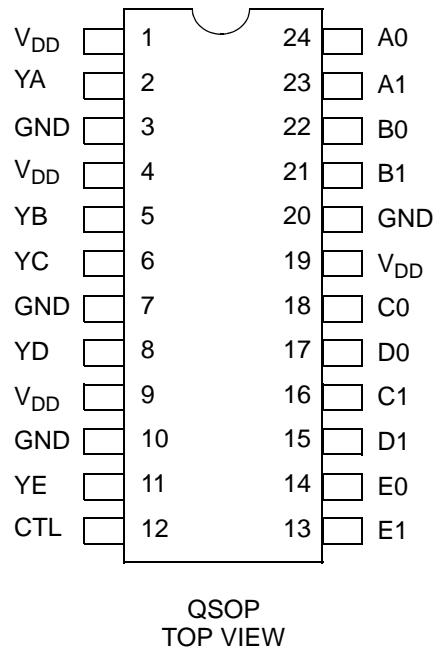

Absolute Maximum Ratings

Symbol	Rating	Min	Max ¹	Unit
TSTG	Storage Temperature Range	- 65	+150	°C
	Supply Voltage to GND Potential	- 0.5	+4	V
	DC Input Voltage	- 0.5	+5.5	V
	DC Output Current	—	120	mA
	Power Dissipation	—	0.5	W

1. Stresses greater than those listed under ABSOLUTE MAXIMUM RATINGS may cause permanent damage to the device. This is a stress rating only and functional operation of the device at these or any other conditions above those indicated in the operational sections of this specification is not implied. Exposure to absolute maximum rating conditions for extended periods may affect reliability.

Capacitance (TA = +25°C, f = 1.0MHz)

Symbol	Parameter	Conditions	Typ	Max ¹	Unit
C _{IN}	Input Capacitance	V _{IN} = 0V	2	3	pF
C _{OFF(IN0, IN1)}	Port I Capacitance, Switch OFF	V _{IN} = 0V	4	6	pF
C _{ON(Y/I)}	Y/I Port Capacitance, Switch ON	V _{IN} = 0V	6	10	pF

1. As applicable to the device type.

Pin Description

Name	Pin #	Function
V _{DD}	1, 4, 9, 19	Positive power supply
GND	3, 7, 10, 20	Ground
X _n	2, 5, 6, 8, 11, 13, 14, 15, 16, 17, 18, 21, 22, 23, 24	Data and CLK
CTL	12	Control

Truth Table

Function	SEL
Y _n to Y ₀	L
Y _n to X ₁	H

Dynamic Electrical Characteristics Over Operating Range

Following Conditions Apply Unless Otherwise Specified:

T_A = 0°C to +70°C, V_{CC} = 3.3V ± 10%, GND = 0V..

Symbol	Parameter	Conditions	Min.	Typ.	Max.	Unit
X _{TALK} ¹	Crosstalk	t = 10MHz	—	-65	—	dB
O _{IRR} ²	Off Isolation	t = 10MHz	—	-70	—	
B _W	Bandwidth - 3dB	C _L = 0pF	—	600	—	MHz

1. See CROSSTALK SETUP for Measurement Setup.

2. See OFF-ISOLATION SETUP for Measurement Setup.

DC Electrical Characteristics Over Operating Range

Following Conditions Apply Unless Otherwise Specified:

T_A = 0°C to +70°C, V_{CC} = 3.3V ± 10%.

Symbol	Parameter	Conditions ¹	Min.	Typ. ²	Max.	Unit
V _{IH} ³	Input HIGH Voltage	Guaranteed Logic HIGH level	2	—	—	V
V _{IL}	Input LOW Voltage	Guaranteed Logic LOW level	-0.5	—	0.8	
V _{IK}	Clamp Diode Voltage	V _{CC} = Max., I _{IN} = -18mA	—	-0.7	-1.2	
I _{IH}	Input HIGH Current	V _{CC} = Max., V _{IN} = V _{CC}	—	—	±5	μA
I _{IL}	Input LOW Current	V _{CC} = Max., V _{IN} = GND	—	—	±5	
I _{OFF}	Power Down Leakage Current	V _{CC} = 0V, V _A = 0V, V _B ≤ 3.6	—	—	—	
R _{ON} ⁴	Switch On-Resistance	V _{CC} = Min., 1.5 ≤ V _{IN} ≤ V _{CC} , I _{IN} = -40mA	—	4	8	
R _{FLAT(ON)}	On-Resistance Flatness	V _{CC} = Min., V _{IN} @ 1.5V and V _{CC} , I _{IN} = -40mA	—	1	—	Ω
ΔR _{ON}	On-Resistance match from center ports to any other port	V _{CC} = Min., 1.5 ≤ V _{IN} ≤ V _{CC} , I _{IN} = -40mA	—	0.9	2	

1. For Max. or Min. conditions, use appropriate value specified under Electrical Characteristics for the applicable device type.

2. Typical values are at V_{CC} = 3.3V, T_A = 25°C ambient and maximum loading.

3. Measured by the voltage drop between Y and I pins at indicated current through the switch. On-Resistance is determined by the lower of the voltages on the two (Y & I) pins.

4. This parameter is determined by device characterization but is not production tested.

Power Supply Characteristics

Symbol	Parameter	Conditions ¹	Min.	Typ. ²	Max.	Unit
I_{CC}	Quiescent Power Supply Current	$V_{CC} = \text{Max.}, V_{IN} = \text{GND or } V_{CC}$	—	—	800	μA

1. For Max. or Min. conditions, use appropriate value specified under Electrical Characteristics for the applicable device.
2. Typical values are at $V_{CC} = 3.3\text{V}$, $T_A = 25^\circ\text{C}$ ambient and maximum loading.

Switching Characteristics Over Operating Range

Following Conditions Apply Unless Otherwise Specified:
 $T_A = 0^\circ\text{C to } +70^\circ\text{C}$, $V_{CC} = 3.3\text{V} \pm 10\%$, $\text{GND} = 0\text{V}$.

Symbol	Description	Min.	Typ. ¹	Max.	Unit
t_{PD}	Propagation Delay ^{2,3}	—	0.25	—	ns
t_{PZH}, t_{PZL}	Line Enable Time - SEL to Y_n , In	0.5	—	15	ns
t_{PHZ}, t_{PLZ}	Line Disable Time - SEL to Y_n , In	0.5	—	9	ns
$t_{SK(O)}$	Output Skew between center port (YC to YD) to any other port(2)	—	0.1	0.2	ns
$t_{SK(P)}$	Skew between opposite transitions of the same output (tPHL- tPLH)(2)	—	0.1	0.2	ns

1. For max. or min. conditions, use appropriate value specified under Electrical Characteristics for the applicable device type.
2. Guaranteed by design.,
3. The bus switch contributes no propagational delay other than the RC delay of the On-Resistance of the switch and the load capacitance. The time constant for the switch alone is of the order of 0.25ns for 10pF load. Since this time constant is much smaller than the rise/fall times of typical driving signals, it adds very little propagational delay to the system. Propagational delay of the bus switch when used in a system is determined by the driving circuit on the driving side of the switch and its interactions with the load on the driven side.

Switching Waveforms

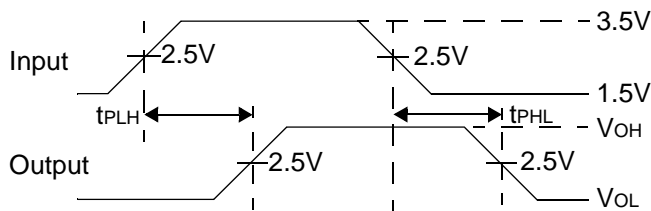

Voltage Waveforms Propagation Delay Times

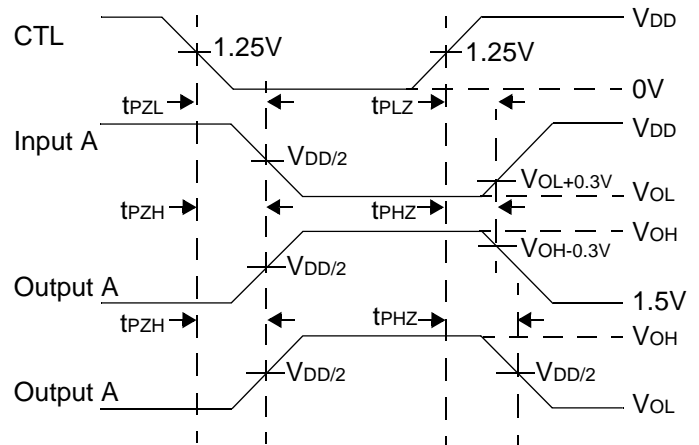

Voltage Waveforms Enable and Disable Times

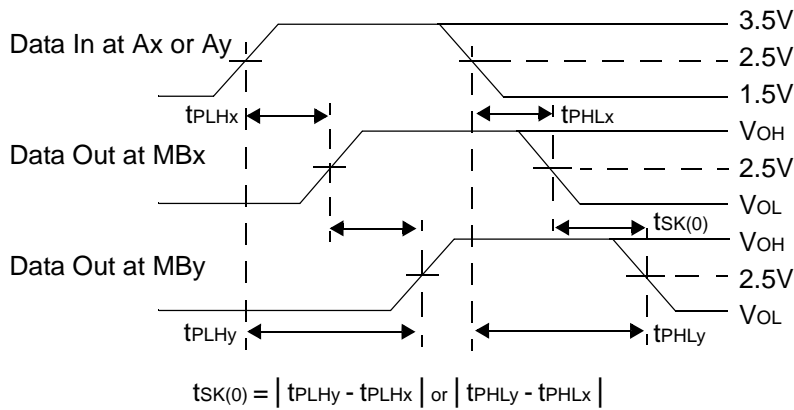

Output Skew - $t_{sk(o)}$

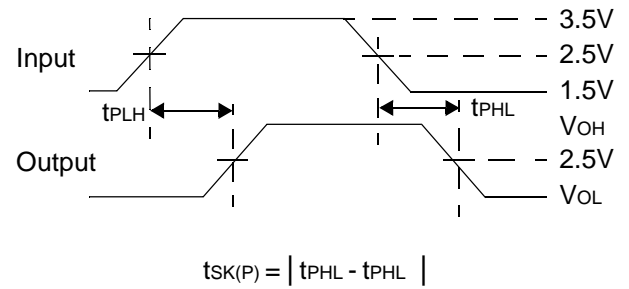

Pulse Skew - $t_{sk(p)}$

Applications Information

Logic Inputs

The logic control inputs can be driven up to +3.6V regardless of the supply voltage. For example, given a +3.3V supply, the output enables or select pins may be driven low to 0V and high to 3.6V. Driving IN Rail-to-RailÆ minimizes power consumption.

Power-supply Sequencing

Proper power-supply sequencing is advised for all CMOS devices. It is recommended to always apply V_{CC} before applying signals to the input/output or control pins.

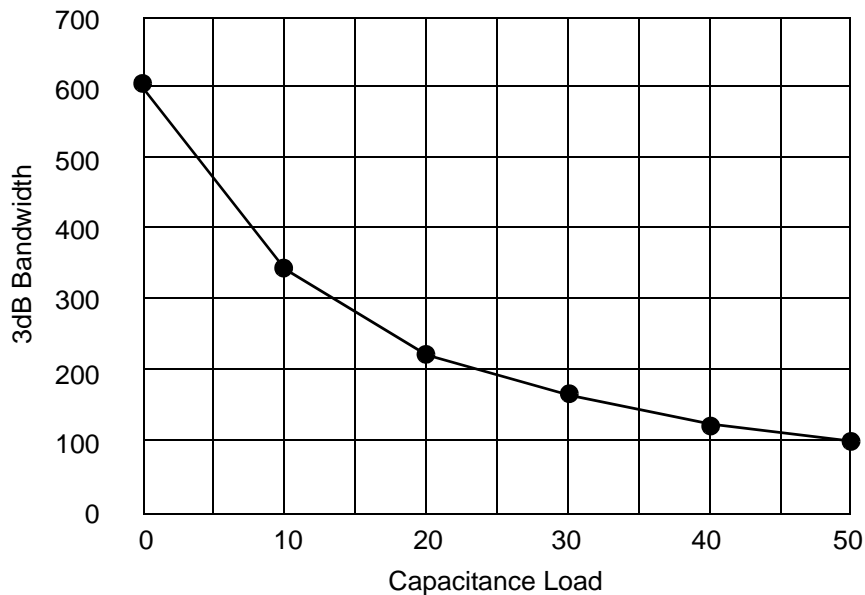

Bandwidth vs. Capacitance

Test Circuit For Electrical Characteristics

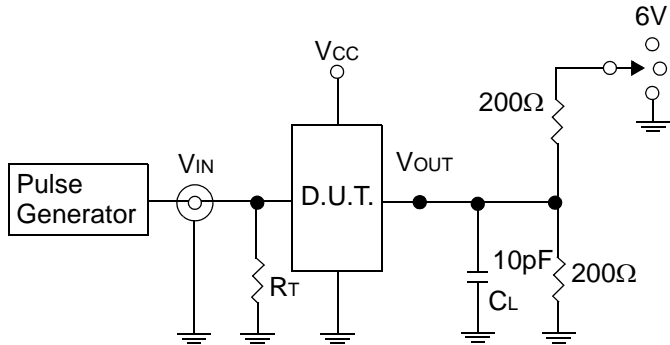

Switch Position

Test	Switch
t_{PZH} , t_{PZL} (output on I-side)	6V
t_{PHZ} , t_{PLZ} (output on I-side)	GND
Prop Delay	Open

- 1 CL = Load capacitance: includes jig and probe capacitance.
- 2 RT = Termination resistance: should be equal to Z_{OUT} of the Pulse Generator.
- 3 Waveform 1 is for an output with internal conditions such that the output is low except when disabled by the output control. Waveform 2 is for an output with internal conditions such that the output is high except when disabled by the output control.
- 4 All input impulses are supplied by generators having the following characteristics: $PRR \leq \text{MHz}$, $Z_o = 50\Omega$, $t_r \leq 2.5\text{ns}$, $t_f \leq 2.5\text{ns}$.
- 5 The outputs are measured one at a time with one transition per measurement.

Test Circuit for Dynamic Electrical Characteristics

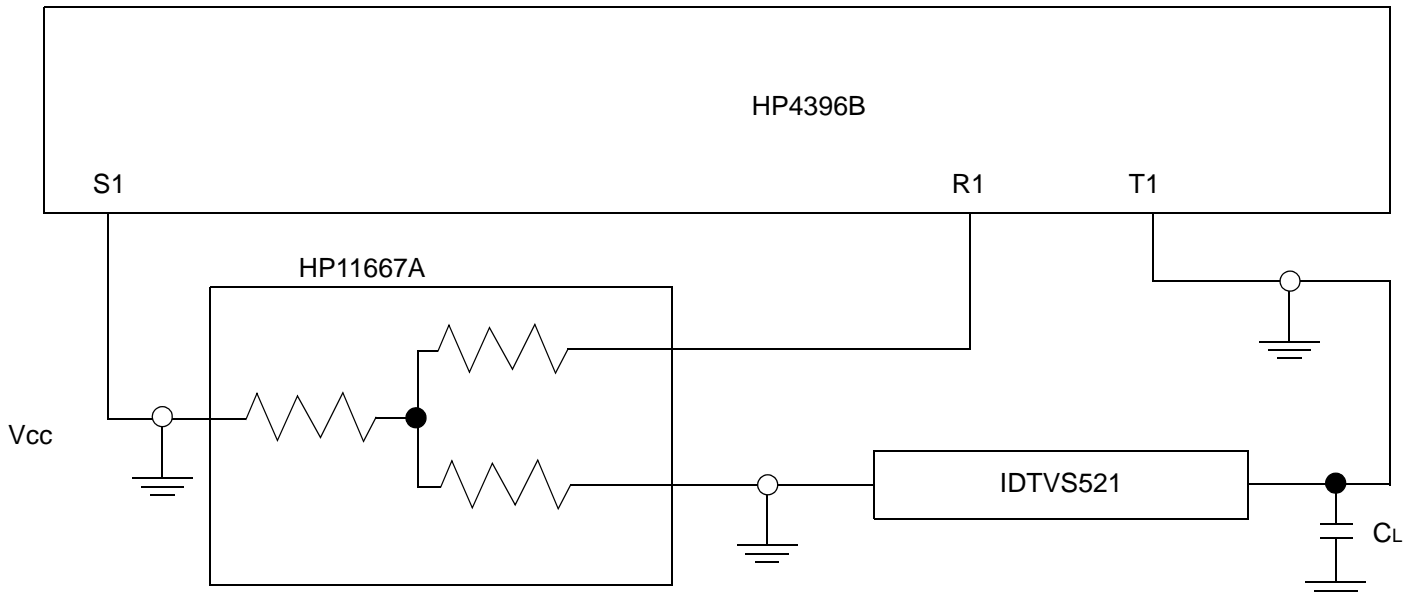

Package Dimensions - QAOP

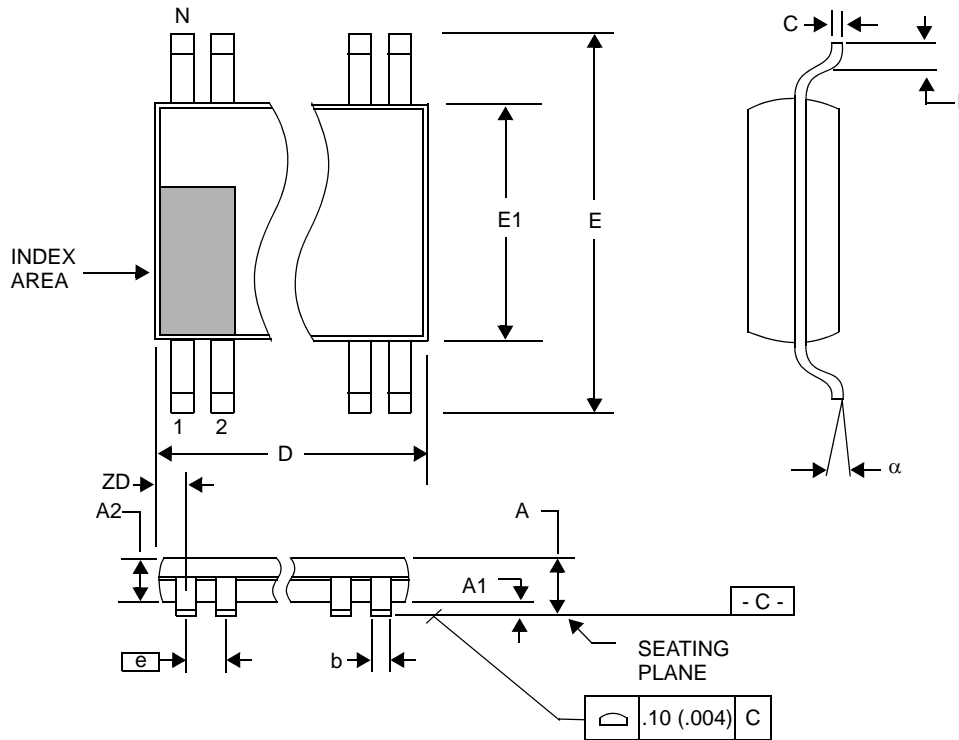

150 mil SSOP (QSOP))

Symbol	In Millimeters Common Dimensions		In Inches Common Dimensions ¹	
	MIN	MAX	MIN	MAX
A	1.35	1.75	.053	.069
A1	0.10	0.25	.004	.010
A2	—	1.50	—	.059
b	0.20	0.30	.008	.012
c	0.18	0.25	.007	.010
D	8.55	8.75	.337	.344
E	5.80	6.20	.228	.244
E1	3.80	4.00	.150	.157
e	.635 BASIC		0.025 BASIC	
L	0.40	1.27	.016	.050
N	24		24	
alpha	0°	8°	0°	8°
ZD	0.84 REF		.394 REF	

1. For reference only. Controlling dimensions are in inches.

Ordering Information

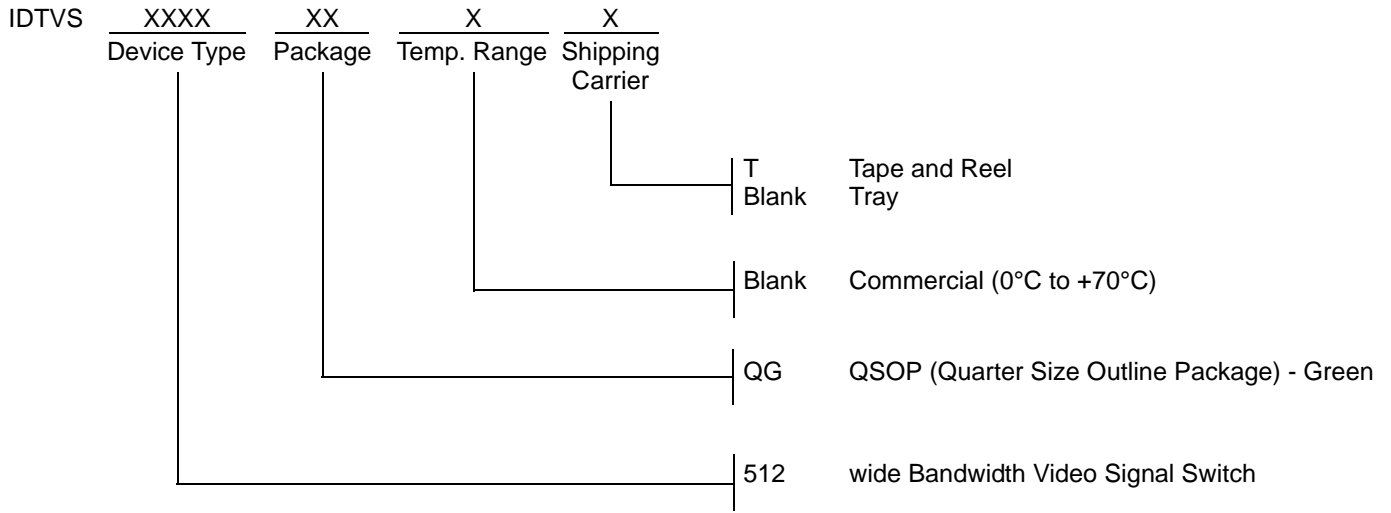

CORPORATE HEADQUARTERS
6024 Silver Creek Valley Road
San Jose, CA 95138

for SALES:
800-345-7015 or 408-284-8200
fax: 408-284-2775
www.idt.com

for Tech Support:
email: videohelp@idt.com

Looking for pricing, stock, or lifecycle information?

Click below to explore more details on WIN SOURCE:

-  [View IDTVS512QG8 on WIN SOURCE](#)
-  [IDT, Integrated Device Technology Inc](#) Information

Optimize Your Supply Chain with WIN SOURCE Solutions

-  Global Sourcing Solution
-  Obsolete Management
-  Cost Control Management
-  Shortage Management
-  Alternative Solution
-  Excess Inventory Management