

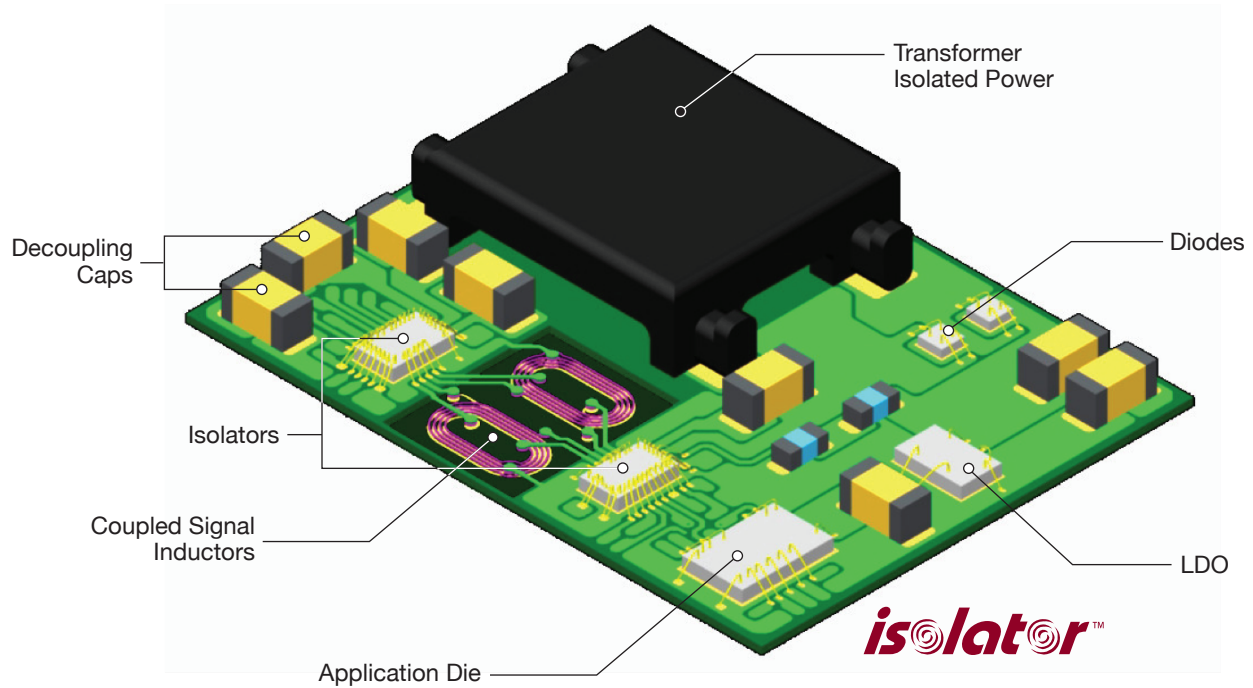

**THE DATASHEET OF  
LTM2887CY-3S#PBF**



# µModule Isolators



## Complete Isolation and Power for Standard Serial Interfaces and Devices

Linear Technology's µModule<sup>®</sup> isolators are complete system-in-package (SiP) solutions that provide up to 7.5kV<sub>RMS</sub> isolation for the most popular serial interfaces and devices, including USB, RS485, RS232, SPI/Digital, I<sup>2</sup>C, ADCs, DACs and switches. Most devices provide up to 1W of isolated power to neighboring components. Boasting high integration and performance in small footprints, absolutely no external components are required.

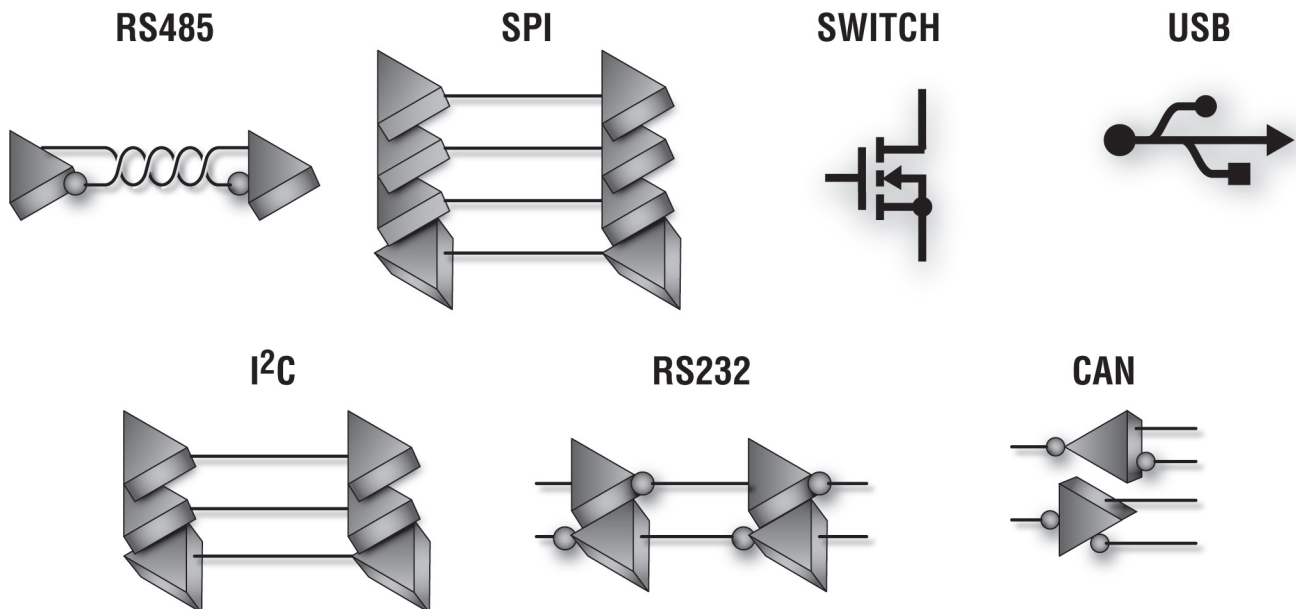

LT, LT, LTC, LTM, Linear Technology, the Linear logo and µModule are registered trademarks and the Isolator logo and AnySide are trademarks of Analog Devices, Inc. All other trademarks are the property of their respective owners.



## Galvanic Isolation

Linear Technology  $\mu$ Module isolators use embedded, inductively coupled coils to pass data differentially across the isolation boundary, resulting in an extremely robust communications scheme. Simple isolated solutions are made available with the integration of isolated data, isolated power and all passive components, including bypass capacitors, in a single package. High distance through-insulation ultimately translates to higher ESD protection and reliability.

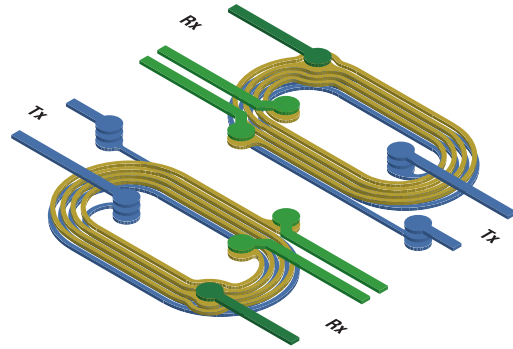

## Common Mode Transient Immunity

A differential signaling scheme enables communication through common mode transient events greater than  $70\text{kV}/\mu\text{s}$ , and is unaffected by the transient without any priority data jitter or data corruption. The system includes data refresh, error checking and safe shutdown for robust digital communications.

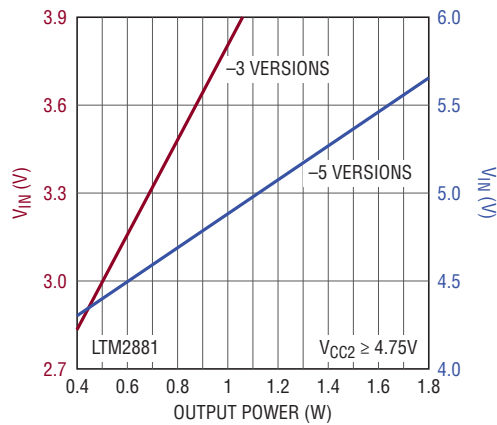
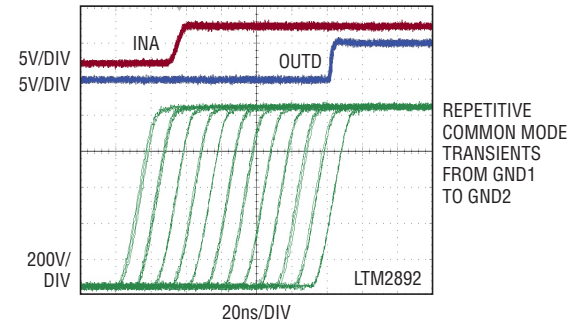

## Isolated Power

With the exception of the LTM<sup>®</sup>2892/LTM2893/LTM2894/LTM2895, all  $\mu$ Module isolators provide at least one isolated power supply for powering neighboring components, such as data converters. These supplies are regulated, up to 65% efficient, fault tolerant and, in some cases, adjustable using a single resistor.

## Safety, EMC and EMI

$\mu$ Module isolators are certified to stringent component level safety, electromagnetic compatibility (EMC) and electromagnetic interference (EMI) standards. All  $\mu$ Module isolators pass accepted safety standards, including UL1577 and CSA component acceptance notice #5A, which test isolation barrier performance under various environmental conditions and require 100% production screening. In addition, all devices are 100% tested to the more sensitive partial discharge IEC 60747 requirements.

EMC refers to a device's ability to operate properly in the presence of EMI. All  $\mu$ Module isolators pass EMC tests per IEC 61000-4-3/-8/-9, which subject the devices to particular magnetic field frequencies and strengths.

EMI refers to a device's actual radiated emissions. All  $\mu$ Module isolators are well below CISPR 22 Class A and B limits, as well as the Federal Communications Commission (FCC) Class A limit.

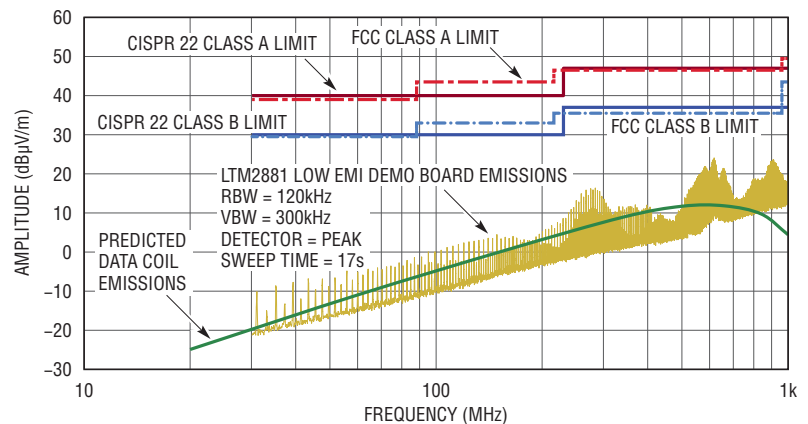

## RS485 Transceivers

- Single TIA/EIA-485-A (and PROFIBUS) Compatible Transceiver
- Half- or Full-Duplex Operation
- Integrated Isolated DC/DC and Bypass Caps
- 1.62V to 5.5V Logic Supply
- Selectable 20Mbps or 250kbps Data Rate
- 30kV/ $\mu$ s Common Mode Transient Immunity
- $\pm 15$ kV HBM ESD
- 14.6mm Creepage & Distance (LTM2885)

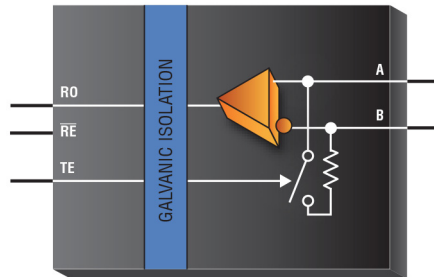
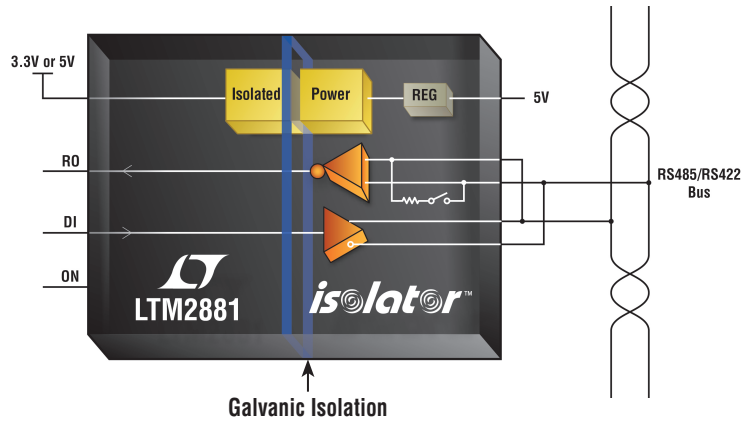

## Integrated Selectable 120 $\Omega$ Termination

A pin-selectable 120 $\Omega$  termination is available for minimizing reflections that may be present on an unterminated transmission line. RS485 networks require 120 $\Omega$  termination resistors to be installed by the end-user based on the physical layout of the twisted-pair wires and the placement of the nodes. Pin-selectable termination allows the proper nodes to be terminated by switching the integrated termination on or off, under software control, without the need of physical intervention by the user.

Part Number	Interface	Isolation ( $V_{RMS}$ )	# Dri/ Rec	Supply Voltage (V)	Max Data Rate	Isolated Power Output(s)	Max Temp	Package
LTM2881	RS485	2500	1/1	5/3.3	20Mbps	5V (1W)	105°C	15mm x 11mm BGA-32 or LGA-32
LTM2885	RS485	6500	1/1	5	20Mbps	5V (1W)	105°C	22mm x 9mm BGA-42

## RS232 Transceiver

- Dual TIA/EIA-232-F Compatible Transceiver
- Half- or Full-Duplex Operation
- Integrated Isolated DC/DC and Bypass Caps
- 1.62V to 5.5V Logic Supply
- Up to 1Mbps Data Rate
- 30kV/ $\mu$ s Common Mode Transient Immunity
- $\pm 10$ kV HBM ESD

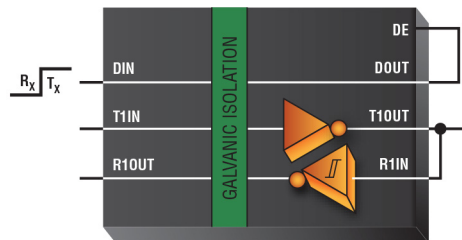
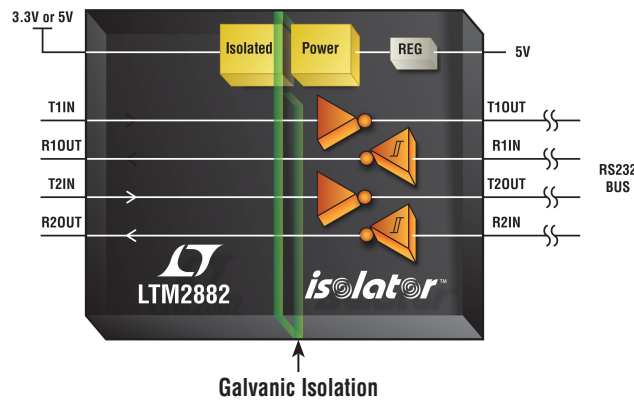

## Flexible Extra Channel

An extra isolated digital channel supports any auxiliary signaling and functions, including slave-side control of the low latency Driver Enable (DE) pin in half-duplex operations. When toggled, each driver is enabled and disabled in less than 2 $\mu$ s, while each receiver remains continuously active.

Part Number	Interface	Isolation ( $V_{RMS}$ )	# Dri/ Rec	Supply Voltage (V)	Max Data Rate	Isolated Power Output(s)	Max Temp	Package
LTM2882	RS232	2500	2/2	5/3.3	1Mbps	5V (1W)	85°C	15mm x 11mm BGA-32 or LGA-32

## SPI or I<sup>2</sup>C Transceivers

- 6-Channel SPI/Digital or I<sup>2</sup>C Transceiver
- Integrated Isolated DC/DC (LTM2883, LTM2886 & LTM2887)
- 1.62V to 5.5V Logic Supply
- 10MHz SPI or 400kHz I<sup>2</sup>C Data Rate
- Up to 50kV/ $\mu$ s Common Mode Transient Immunity
- Up to  $\pm$ 15kV HBM ESD

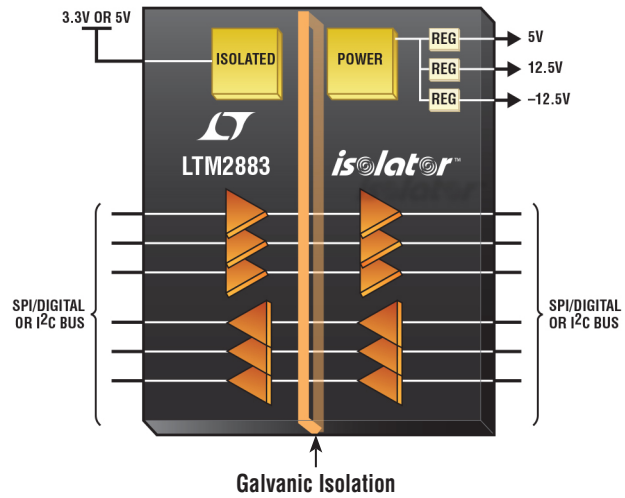
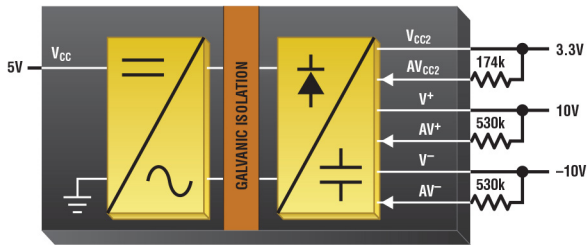

## Multiple Isolated Power Outputs

Except for the LTM2892, up to three regulated isolated power outputs are available and source up to 100mA to neighboring isolated components, eliminating the need for separate isolated supplies. Some of these power outputs may be adjusted from their nominal value using a single external resistor.

Part Number	Interface	Isolation (# V <sub>RMS</sub> )	# Dr/ Rec	Supply Voltage (V)	Max Data Rate	Isolated Power Output(s)	Max Temp	Package
LTM2883	SPI/I <sup>2</sup> C	2500	3/3	5/3.3	10MHz	Adj. 3V to 5V, Adj. $\pm$ 12V (0.6W)	85°C	15mm x 11mm BGA-32
LTM2886	SPI/I <sup>2</sup> C	2500	3/3	5/3.3	10MHz	Adj. 3V to 5V, Fixed. $\pm$ 5V (1W)	125°C	15mm x 11mm BGA-32
LTM2887	SPI/I <sup>2</sup> C	2500	3/3	5/3.3	10MHz	Adj. 1.8V to 5V, Adj. 0.6 to 5V (1W)	125°C	15mm x 11mm BGA-32
LTM2892	SPI/I <sup>2</sup> C	3500	3/3	1.62 to 5.5	10MHz	-	125°C	9mm x 6mm BGA-24

## SPI Data Converter Controllers

- Up to 100MHz SPI Interface with Data Converter Controls
- Configurable SPI Word Length: 8 to 32 Bits
- Low 30pS<sub>RMS</sub> Jitter Conversion Start and /LOAD Signals
- Three Isolated Control or Multiplexer Select Signals
- 1.71V to 5.5V Logic Supply

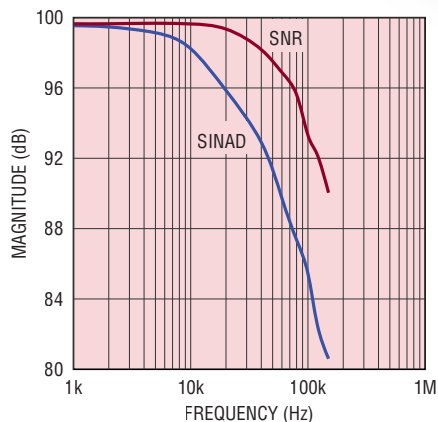
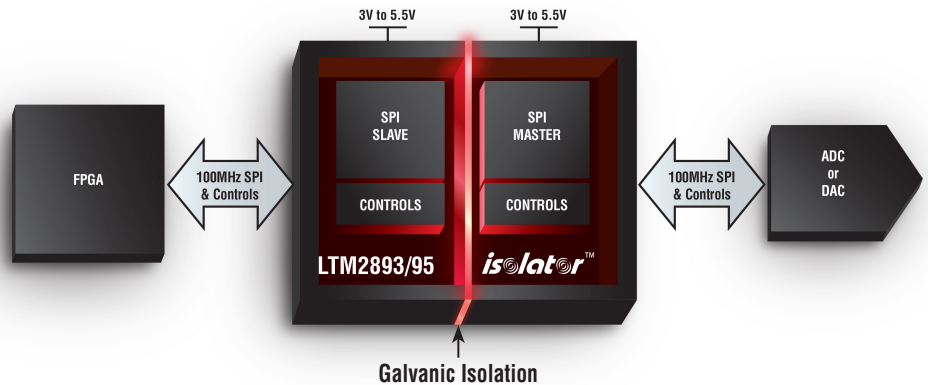

## Optimized for High Performance Conversions

Up to 10 isolated logic channels support the most demanding data converters, as well as dual data converter configurations, analog multiplexers and programmable gain amplifiers. Crucial data converter specifications, such as high signal-to-noise ratio (SNR) or low jitter, are maintained with SPI read/write speeds of up to 100MHz.

Part Number	Interface	Isolation (# V <sub>RMS</sub> )	# Dr/ Rec	Supply Voltage (V)	Max Data Rate	Isolated Power Output(s)	Max Temp	Package
LTM2893	SPI ADC	6000	1/1	3 to 5.5	100MHz	-	125°C	15mm x 6mm BGA-36
LTM2895	SPI DAC	6000	1/1	3 to 5.5	100MHz	-	125°C	15mm x 6mm BGA-36

## USB Transceivers

- USB 2.0 Full Speed (12Mbps) and Low Speed (1.5Mbps) Compatible
- Integrated Isolated DC/DC, External or Bus Powered (LTM2884)
- 17.4mm Creepage Distance (LTM2894)
- Up to 50kV/ $\mu$ s Common Mode Transient Immunity
- Up to  $\pm$ 20kV HBM ESD

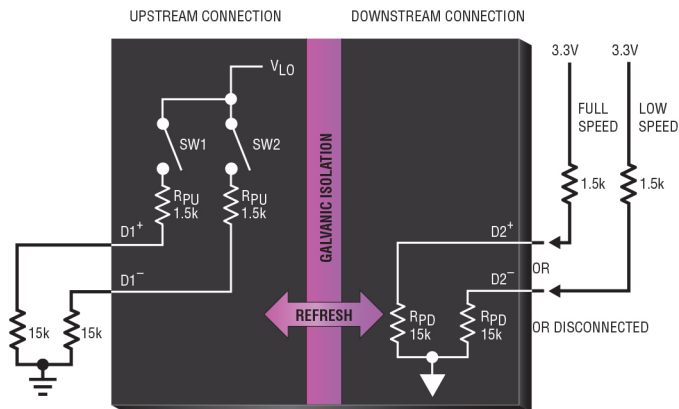
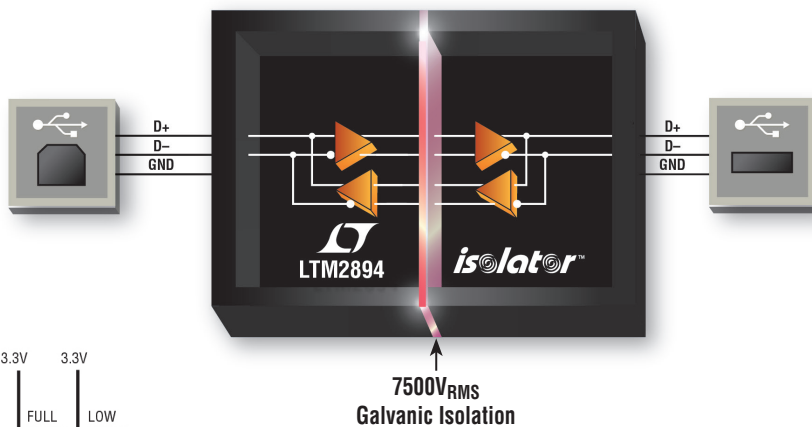

## Auto-Configuration of Bus Speed

Automatic speed selection configures integrated pull-up resistors on the upstream port – for 12Mbps (full speed) or 1.5Mbps (low speed) operation – to match those sensed on the downstream device, eliminating external bus pull-up resistors and any associated switches, jumpers or software.

Part Number	Interface	Isolation ( $V_{RMS}$ )	# Dri/ Rec	Supply Voltage (V)	Max Data Rate	Isolated Power Output(s)	Max Temp	Package
LTM2884	USB	2500	1/1	4.4 to 16.5	12Mbps	2.5W from External Supply, 1W from USB	105°C	15mm x 15mm BGA-44
LTM2894	USB	7500	1/1	4.4 to 36	12Mbps	–	125°C	22mm x 6mm BGA-24

## CAN Transceiver

- CAN FD Compliant
- Up to 4Mbps Data Rate
- Integrated Isolated DC/DC and Bypass Caps
- 1.62V to 5.5V Logic Supply
- $\pm$ 60V Fault Protection
- 30kV/ $\mu$ s Common Mode Transient Immunity
- $\pm$ 25kV HBM ESD

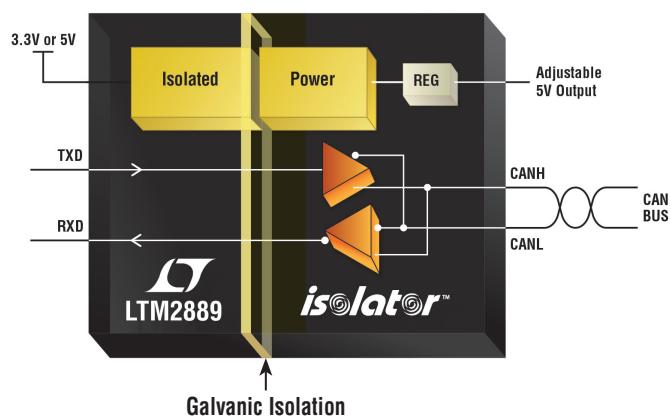

Parameter	DeviceNet	ISO 11898-2	LTM2889
Number of Nodes	64	N/A	166
Min Differential Input Resistance	20k	10k	50k
Differential Input Capacitance	25pF (Max)	10pF (Nom)	8.4pF (Typ)
Bus Pin Voltage Range (Survivable)	-25V to 18V	-3V to 16V (for Battery)	-60V to 60V
Bus Pin Voltage Range (Operation)	-5V to 10V	-2V to 7V	-36V to 36V ( $V_{CC} = 5V$ )
Connector Mis-Wiring Tests, All Pin-Pin Combinations	$\pm$ 18V	N/A	$\pm$ 60V

## ISO 11898-2 & DeviceNet Compatible

Designed for road vehicles, ISO 11898-2:2003 is the section of the CAN standard that defines the physical and data link layers of CAN, requiring CAN transceivers to support 1Mbps data and other parameters (see table). The LTM2889 meets all of these requirements, in addition to the more stringent requirements of DeviceNet which is commonly used in automation networks to interconnect control devices for data exchange.

Part Number	Interface	Isolation ( $V_{RMS}$ )	# Dri/ Rec	Supply Voltage (V)	Max Data Rate	Isolated Power Output(s)	Max Temp	Package
LTM2889	CAN	2500	1/1	5/3.3	4Mbps	Adj. 3V to 5V (0.75W)	125°C	15mm x 11mm BGA-32

## Switch Controller

- Load Switch or Hot Swap Controller with I<sup>2</sup>C Telemetry
- 10-Bit ADC Monitors Current and Two Voltages
- Integrated Isolated DC/DC and Bypass Caps
- 3V to 5.5V Logic Supply
- 30kV/μs Common Mode Transient Immunity
- ±20kV HBM ESD
- 14.6mm Creepage Distance



## 270V Load Soft-Start

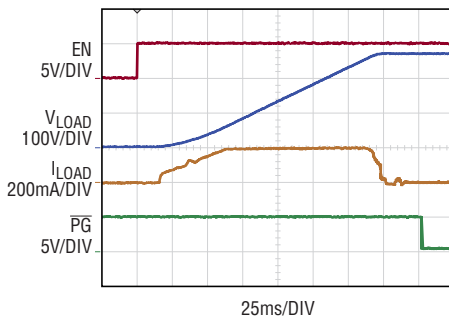

## Summary

The LTM9100 μModule is an all-in-one solution for controlling, protecting, and monitoring high voltage power supplies up to 1000V<sub>DC</sub>. A 5kV<sub>RMS</sub> galvanic isolation barrier separates the digital interface from the switch controller driving an external N-channel MOSFET or IGBT switch. Isolated digital measurements of load current, bus voltage, and temperature are accessed via the I<sup>2</sup>C/SMBus interface, enabling power and energy monitoring of the high voltage bus. The LTM9100 saves design time, certification effort, and board area by wrapping all the needed functionality, including digital telemetry and isolated power, in a compact BGA package.

## Flexible Anyside™ Configuration

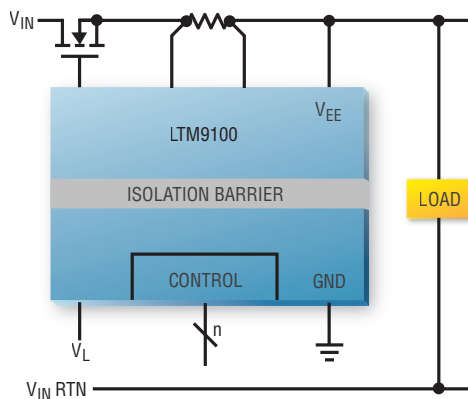

**High Side (Positive) Application**

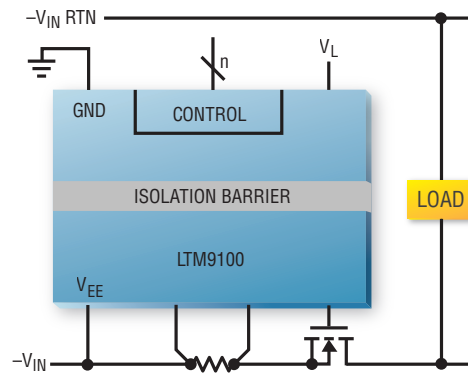

**Low Side (Negative) Application**

Due to its isolated nature, the LTM9100 is easily configured for high side, low side (ground return), and floating applications. Inrush current is minimized by soft starting the load, and the supply is protected from overload and short-circuits with a current-limited circuit breaker. The LTM9100 is versatile enough to control inrush current not just in hot-swappable cards, but also in AC transformers, motor drives, and inductive loads.

Part Number	Interface	Isolation (V <sub>RMS</sub> )	# Dr/ Rec	Supply Voltage (V)	Max Data Rate	Isolated Power Output(s)	Max Temp	Package
LTM9100	Switch/Monitoring	5000	3/3	5	–	10.4V (0.5W), 5V (0.075W)	105°C	22mm × 9mm BGA-42





Reliability

	LTM28xx BGA		LTM28xx LGA	
	Device Hours or Cycles	Failures	Device Hours or Cycles	Failures
High Temperature Bake (150°C)	2692k	0	2069	0
Operating Life Test (125°C Equivalent)	–	–	308k	0
Temperature Cycle <sup>1</sup> (-65°C to 150°C)	1024k	0	1024k	0
Thermal Shock Cycle (-65°C to 150°C)	1227k	0	1035k	0



Environmental Compliance

µModule power products in BGA packages with SAC305 solder balls and LGA packages are halogen-free and RoHS compliant. Select products are also available in BGA packages with SnPb solder balls. Contact your Linear Technology authorized sales representative for details. The materials declaration file for all released products is available at: [www.linear.com/umodule](http://www.linear.com/umodule)



Design Support

### PCB Layout and Assembly

- Quick Start Guide: µModule LGA and BGA Packaging Care and Assembly Instructions
- LGA Package Assembly Considerations
- BGA Package Assembly Considerations

### Application Notes

- AN125 Using the LTM2881 as an Isolated 5V Power Supply

### CAD Symbols and Footprints

The downloadable zip file at the link includes the schematic symbols and PCB footprints compatible with Mentor Graphics PADS v9.5 or later, and Cadence ORCAD v16.5 or later.

- [LTM28xx Series](#)

### Package Mark Codes

The part number, lot number, date code and final assembly location are marked on the top of the package to facilitate product traceability. The lot number consists of a single letter followed by three to five numbers. The date code consists of four numbers in a YYWW format and is commonly followed by a two letter code indicating the country of final assembly: MY for Malaysia and KR for South Korea. The “e4” or “e1” mark indicates an RoHS compliant package.

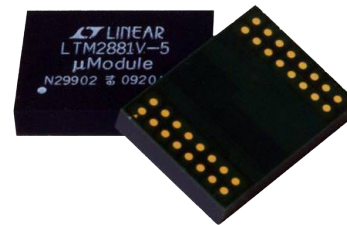

### Demonstration Circuits

Demonstration circuits, along with associated bill of materials (BOM) and Gerber files are available for all products.

Part Number	Interface/Device	Demonstration Circuit Number	Description
LTM2881	RS485	DC1503	Demo board to evaluate full functionality and performance of IC
		DC1746	Low EMI Demo board (for EMI evaluation purposes only, no V <sub>I</sub> and no GPIO)
LTM2885	RS485	DC1794	Low EMI Demo board to evaluate full functionality and performance of IC
		DC1554	Demo board to evaluate full functionality and performance of IC
LTM2882	RS232	DC1747	Low EMI Demo board (for EMI evaluation purposes only, no V <sub>I</sub> and no GPIO)
		DC1748	Demo board to evaluate full functionality and performance of IC
LTM2883	SPI or I <sup>2</sup> C	DC1790	Demo board to evaluate full functionality and performance of IC
LTM2886	SPI or I <sup>2</sup> C	DC1791	Demo board to evaluate full functionality and performance of IC
LTM2887	SPI or I <sup>2</sup> C	DC1957	SPI Demo board to evaluate full functionality and performance of IC
		DC1986	I <sup>2</sup> C Demo board to evaluate full functionality and performance of IC
LTM2893	SPI ADC	DC2405	Demo board to evaluate full functionality and performance of IC
LTM2895	SPI DAC	DC2589	Demo board to evaluate full functionality and performance of IC
LTM2884	USB	DC1789	Demo board to evaluate full functionality and performance of IC
		LTP2884	In-Line USB Isolator (for purchase only)
LTM2894	USB	DC2438	Demo board to evaluate full functionality and performance of IC
LTM2889	CAN	DC1903	Demo board to evaluate full functionality and performance of IC
LTM9100	Switch	DC2423	Demo board to evaluate full functionality and performance of IC

## Looking for pricing, stock, or lifecycle information?

Click below to explore more details on WIN SOURCE:

 [View LTM2887CY-3S#PBF on WIN SOURCE](#)

 [Linear Technology](#) Information

## Optimize Your Supply Chain with WIN SOURCE Solutions

-  Global Sourcing Solution
-  Obsolete Management
-  Cost Control Management
-  Shortage Management
-  Alternative Solution
-  Excess Inventory Management