

YXF SERIES
105°C Long Life

•Load Life : 105°C 4000~10000 hours.

◆SPECIFICATIONS

Items	Characteristics																														
Category Temperature Range	-40~+105°C																														
Rated Voltage Range	6.3~100Vdc																														
Capacitance Tolerance	±20%(20°C,120Hz)																														
Leakage Current(MAX)	I=0.01CV or 3µA whichever is greater.(After 2 minutes) I=Leakage Current(µA) C=Capacitance(µF) V=Rated Voltage(Vdc)																														
Dissipation Factor(MAX) (tanδ)	<table border="1"> <tr> <td>Rated Voltage (Vdc)</td> <td>6.3</td> <td>10</td> <td>16</td> <td>25</td> <td>35</td> <td>50</td> <td>63</td> <td>100</td> <td>(20°C,120Hz)</td> </tr> <tr> <td>tanδ</td> <td>0.22</td> <td>0.19</td> <td>0.16</td> <td>0.14</td> <td>0.12</td> <td>0.10</td> <td>0.09</td> <td>0.08</td> <td></td> </tr> </table> <p>When capacitance is over 1000µF, tanδ shall be added 0.02 to the listed value with increase of every 1000µF.</p>	Rated Voltage (Vdc)	6.3	10	16	25	35	50	63	100	(20°C,120Hz)	tanδ	0.22	0.19	0.16	0.14	0.12	0.10	0.09	0.08											
Rated Voltage (Vdc)	6.3	10	16	25	35	50	63	100	(20°C,120Hz)																						
tanδ	0.22	0.19	0.16	0.14	0.12	0.10	0.09	0.08																							
Endurance	<p>After applying rated voltage with rated ripple current for specified time at 105°C, the capacitors shall meet the following requirements.</p> <table border="1"> <tr> <td>Capacitance Change</td> <td>Within ±25% of the initial value.</td> <td rowspan="3"> <table border="1"> <tr> <td>Case Size</td> <td colspan="2">Life Time (hrs)</td> </tr> <tr> <td></td> <td>6.3~10Vdc</td> <td>16~100Vdc</td> </tr> <tr> <td>φD≤6.3</td> <td>4000</td> <td>5000</td> </tr> <tr> <td>φD=8,10</td> <td>6000</td> <td>7000</td> </tr> <tr> <td>φD≥12.5</td> <td>8000</td> <td>10000</td> </tr> </table> </td> </tr> <tr> <td>Dissipation Factor</td> <td>Not more than 200% of the specified value.</td> </tr> <tr> <td>Leakage Current</td> <td>Not more than the specified value.</td> </tr> </table>	Capacitance Change	Within ±25% of the initial value.	<table border="1"> <tr> <td>Case Size</td> <td colspan="2">Life Time (hrs)</td> </tr> <tr> <td></td> <td>6.3~10Vdc</td> <td>16~100Vdc</td> </tr> <tr> <td>φD≤6.3</td> <td>4000</td> <td>5000</td> </tr> <tr> <td>φD=8,10</td> <td>6000</td> <td>7000</td> </tr> <tr> <td>φD≥12.5</td> <td>8000</td> <td>10000</td> </tr> </table>	Case Size	Life Time (hrs)			6.3~10Vdc	16~100Vdc	φD≤6.3	4000	5000	φD=8,10	6000	7000	φD≥12.5	8000	10000	Dissipation Factor	Not more than 200% of the specified value.	Leakage Current	Not more than the specified value.								
Capacitance Change	Within ±25% of the initial value.	<table border="1"> <tr> <td>Case Size</td> <td colspan="2">Life Time (hrs)</td> </tr> <tr> <td></td> <td>6.3~10Vdc</td> <td>16~100Vdc</td> </tr> <tr> <td>φD≤6.3</td> <td>4000</td> <td>5000</td> </tr> <tr> <td>φD=8,10</td> <td>6000</td> <td>7000</td> </tr> <tr> <td>φD≥12.5</td> <td>8000</td> <td>10000</td> </tr> </table>	Case Size		Life Time (hrs)			6.3~10Vdc	16~100Vdc	φD≤6.3	4000	5000	φD=8,10	6000	7000	φD≥12.5	8000	10000													
Case Size	Life Time (hrs)																														
	6.3~10Vdc		16~100Vdc																												
φD≤6.3	4000	5000																													
φD=8,10	6000	7000																													
φD≥12.5	8000	10000																													
Dissipation Factor	Not more than 200% of the specified value.																														
Leakage Current	Not more than the specified value.																														
Low Temperature Stability Impedance Ratio(MAX)	<table border="1"> <tr> <td>Rated Voltage (Vdc)</td> <td>6.3</td> <td>10</td> <td>16</td> <td>25</td> <td>35</td> <td>50</td> <td>63</td> <td>100</td> <td>(120Hz)</td> </tr> <tr> <td>Z(-25°C)/Z(20°C)</td> <td>4</td> <td>3</td> <td>2</td> <td>2</td> <td>2</td> <td>2</td> <td>2</td> <td>2</td> <td></td> </tr> <tr> <td>Z(-40°C)/Z(20°C)</td> <td>8</td> <td>6</td> <td>4</td> <td>3</td> <td>3</td> <td>3</td> <td>3</td> <td>3</td> <td></td> </tr> </table>	Rated Voltage (Vdc)	6.3	10	16	25	35	50	63	100	(120Hz)	Z(-25°C)/Z(20°C)	4	3	2	2	2	2	2	2		Z(-40°C)/Z(20°C)	8	6	4	3	3	3	3	3	
Rated Voltage (Vdc)	6.3	10	16	25	35	50	63	100	(120Hz)																						
Z(-25°C)/Z(20°C)	4	3	2	2	2	2	2	2																							
Z(-40°C)/Z(20°C)	8	6	4	3	3	3	3	3																							

◆MULTIPLIER FOR RIPPLE CURRENT

Frequency (Hz)		120	1k	10k	100k≤
Coefficient	1uF	0.35	0.60	0.80	1.00
	2.2~10uF	0.42	0.60	0.80	1.00
	22~33uF	0.55	0.75	0.90	1.00
	47~330uF	0.70	0.85	0.95	1.00
	470~1000uF	0.75	0.90	0.98	1.00
	2200~15000uF	0.80	0.95	1.00	1.00

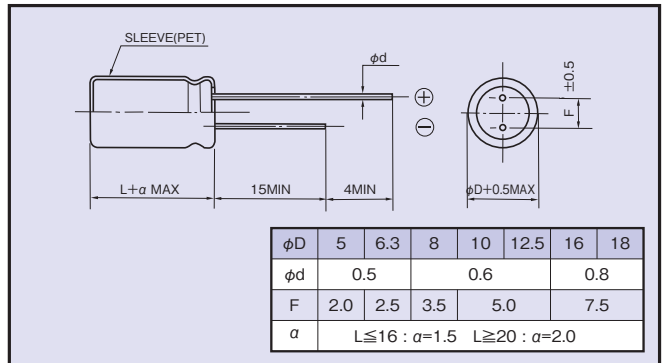
◆DIMENSIONS (mm)

◆PART NUMBER

◆OPTION

PET Sleeve	Code
	EFC

◆STANDARD SIZE

Rated Voltage (Vdc)	Capacitance (μF)	Size φD×L(mm)	Rated ripple current (mA r.m.s./105°C, 100kHz)	Impedance (Ω MAX)	
				20°C, 100kHz	-10°C, 100kHz
6.3	100	5×11	150	0.90	3.6
	220	6.3×11	250	0.40	1.6
	330	6.3×11	250	0.40	1.6
	470	8×11.5	400	0.25	1.0
	1000	10×12.5	580	0.16	0.65
	2200	12.5×20	1300	0.062	0.21
	3300	12.5×20	1300	0.062	0.21
	4700	16×25	1850	0.034	0.096
	6800	16×25	1850	0.034	0.096
	10000	16×31.5	2000	0.029	0.087
15000	18×35.5	2200	0.025	0.058	
10	100	5×11	150	0.90	3.6
	220	6.3×11	250	0.40	1.6
	330	8×11.5	400	0.25	1.0
	470	8×11.5	400	0.25	1.0
	1000	10×16	770	0.12	0.46
	2200	12.5×20	1300	0.062	0.21
	3300	12.5×25	1650	0.048	0.16
	4700	16×25	1850	0.034	0.096
	6800	16×31.5	2000	0.029	0.087
	10000	18×35.5	2200	0.025	0.058
16	47	5×11	150	0.90	3.6
	100	6.3×11	250	0.40	1.6
	220	8×11.5	400	0.25	1.0
	330	8×11.5	400	0.25	1.0
	470	10×12.5	580	0.16	0.65
	1000	10×20	1050	0.078	0.30
	2200	12.5×25	1650	0.048	0.16
	3300	16×25	1850	0.034	0.096
	4700	16×31.5	2000	0.029	0.087
	6800	18×35.5	2200	0.025	0.058
25	33	5×11	150	0.90	3.6
	47	5×11	150	0.90	3.6
	100	6.3×11	250	0.40	1.6
	220	8×11.5	400	0.25	1.0
	330	10×12.5	580	0.16	0.65
	470	10×16	770	0.12	0.46
	1000	12.5×20	1300	0.062	0.21
	2200	16×25	1850	0.034	0.096
	3300	16×31.5	2000	0.029	0.087
	4700	18×35.5	2200	0.025	0.058
35	33	5×11	150	0.90	3.6
	47	6.3×11	250	0.40	1.6
	100	8×11.5	400	0.25	1.0
	220	10×12.5	580	0.16	0.65
	330	10×16	770	0.12	0.46
	470	10×20	1050	0.078	0.30
	1000	12.5×25	1650	0.048	0.16
	2200	16×31.5	2000	0.029	0.087
3300	18×35.5	2200	0.025	0.058	

Rated Voltage (Vdc)	Capacitance (μF)	Size φD×L(mm)	Rated ripple current (mA r.m.s./105°C, 100kHz)	Impedance (Ω MAX)	
				20°C, 100kHz	-10°C, 100kHz
50	1	5×11	30	4.0	8.0
	2.2	5×11	43	2.5	6.0
	3.3	5×11	53	2.2	5.6
	4.7	5×11	88	1.9	5.0
	10	5×11	100	1.5	4.0
	22	5×11	150	0.90	3.6
	33	6.3×11	250	0.40	1.6
	47	6.3×11	250	0.40	1.6
	100	8×11.5	400	0.25	1.0
	220	10×16	770	0.12	0.46
	330	10×20	1050	0.078	0.30
	470	12.5×20	1300	0.062	0.21
	1000	16×25	1850	0.034	0.096
	2200	18×35.5	2200	0.025	0.058
63	10	5×11	87	2.3	9.3
	22	6.3×11	140	1.3	5.2
	33	6.3×11	140	1.2	5.0
	47	8×11.5	210	0.63	2.8
	100	10×12.5	300	0.43	1.8
	220	10×20	520	0.21	0.84
	330	12.5×20	660	0.16	0.64
	470	12.5×25	750	0.12	0.45
	1000	16×31.5	1390	0.054	0.20
	100	1	5×11	20	4.5
2.2		5×11	30	3.0	13.0
3.3		5×11	40	2.7	11.0
4.7		5×11	65	2.5	10.0
10		6.3×11	140	1.2	5.0
22		8×11.5	160	0.63	2.8
33		10×12.5	230	0.43	1.8
47		10×16	290	0.31	1.5
100		12.5×20	430	0.16	0.64
220		16×25	900	0.073	0.27
330	16×25	900	0.073	0.27	

Looking for pricing, stock, or lifecycle information?

Click below to explore more details on WIN SOURCE:

-  [View 10YXF470MEFC8X11.5 on WIN SOURCE](#)
-  [Rubycon Information](#)

Optimize Your Supply Chain with WIN SOURCE Solutions

-  Global Sourcing Solution
-  Obsolete Management
-  Cost Control Management
-  Shortage Management
-  Alternative Solution
-  Excess Inventory Management