



**THE DATASHEET OF  
ADF7025BCPZ**



## FEATURES

Low power, zero-IF RF transceiver

Frequency bands

431 MHz to 464 MHz

862 MHz to 870 MHz

902 MHz to 928 MHz

Data rates supported

9.6 kbps to 384 kbps, FSK

2.3 V to 3.6 V power supply

Programmable output power

-16 dBm to +13 dBm in 63 steps

Receiver sensitivity

-104.2 dBm at 38.4 kbps, FSK

-100 dBm at 172.8 kbps, FSK

-95.8 dBm at 384 kbps, FSK

Low power consumption

19 mA in receive mode

28 mA in transmit mode (10 dBm output)

On-chip VCO and Fractional-N PLL

On-chip, 7-bit ADC and temperature sensor

Digital RSSI

Integrated TRx switch

Leakage current < 1  $\mu$ A in power-down mode

## APPLICATIONS

Wireless audio/video

Remote control/security systems

Wireless metering

Keyless entry

Home automation

## FUNCTIONAL BLOCK DIAGRAM

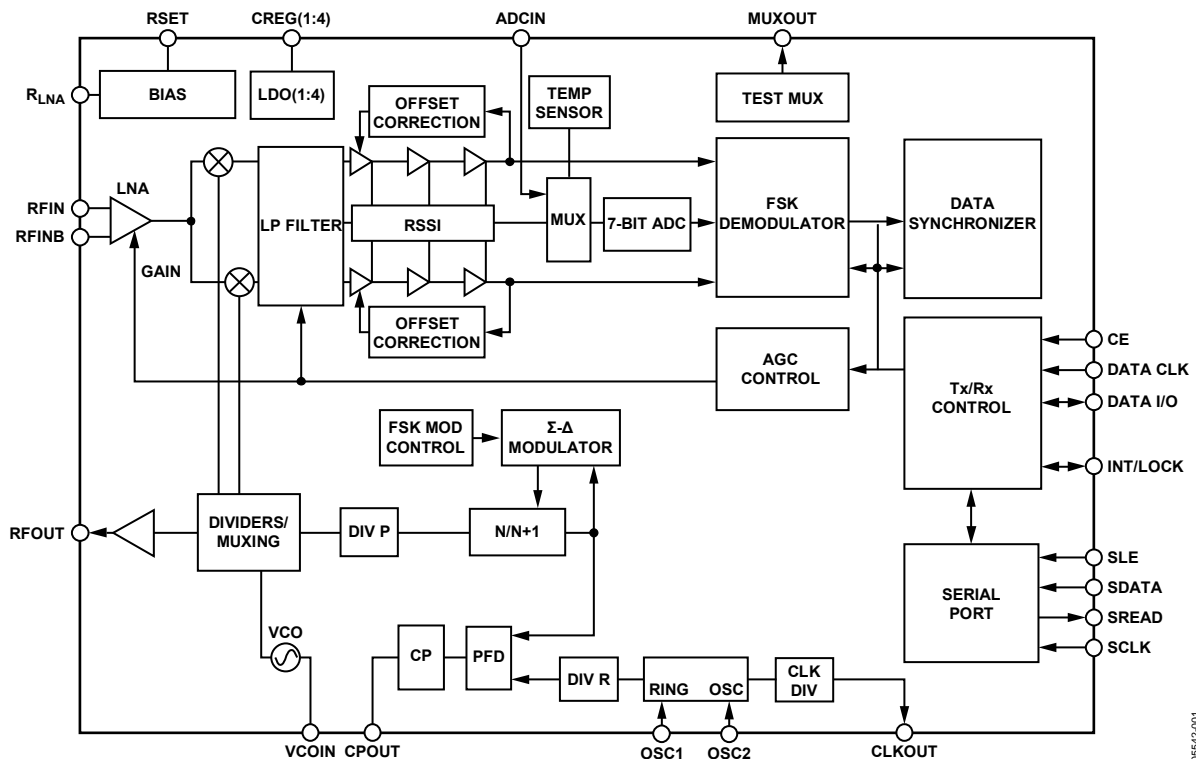

Figure 1.

05542-001

Rev. C

[Document Feedback](#)

Information furnished by Analog Devices is believed to be accurate and reliable. However, no responsibility is assumed by Analog Devices for its use, nor for any infringements of patents or other rights of third parties that may result from its use. Specifications subject to change without notice. No license is granted by implication or otherwise under any patent or patent rights of Analog Devices. Trademarks and registered trademarks are the property of their respective owners.

One Technology Way, P.O. Box 9106, Norwood, MA 02062-9106, U.S.A.

Tel: 781.329.4700

©2006–2016 Analog Devices, Inc. All rights reserved.

[Technical Support](#)

[www.analog.com](http://www.analog.com)

**TABLE OF CONTENTS**

Features .....	1	Automatic Sync Word Recognition .....	22
Applications.....	1	Applications Section.....	23
Functional Block Diagram .....	1	LNA/PA Matching.....	23
Revision History .....	2	Transmit Protocol and Coding Considerations .....	24
General Description .....	3	Device Programming after Initial Power-Up .....	24
Specifications.....	4	Interfacing to Microcontroller/DSP .....	24
Timing Characteristics.....	7	Serial Interface .....	27
Timing Diagrams.....	7	Readback Format.....	27
Absolute Maximum Ratings.....	9	Registers.....	28
ESD Caution.....	9	Register 0—N Register.....	28
Pin Configuration and Function Descriptions.....	10	Register 1—Oscillator/Filter Register.....	29
Typical Performance Characteristics .....	12	Register 2—Transmit Modulation Register .....	30
Frequency Synthesizer .....	15	Register 3—Receiver Clock Register .....	31
Reference Input Section.....	15	Register 4—Demodulator Setup Register .....	32
Choosing Channels for Best System Performance.....	17	Register 5—Sync Byte Register .....	33
Transmitter .....	18	Register 6—Correlator/Demodulator Register .....	34
RF Output Stage.....	18	Register 7—Readback Setup Register .....	35
Modulation Scheme .....	18	Register 8—Power-Down Test Register .....	36
Receiver .....	19	Register 9—AGC Register.....	37
RF Front End.....	19	Register 10—AGC 2 Register.....	38
RSSI/AGC.....	20	Register 12—Test Register.....	39
FSK Demodulators on the ADF7025.....	20	Register 13—Offset Removal and Signal Gain Register .....	40
FSK Correlator/Demodulator.....	20	Outline Dimensions .....	41
Linear FSK Demodulator .....	22	Ordering Guide .....	41

**REVISION HISTORY**

**9/2016—Rev. B to Rev. C**

Changes to General Description Section .....	3
Changes to Interfacing to Microcontroller/DSP Section and Figure 34 .....	24

**8/2012—Rev. A to Rev. B**

Changed CP-48-3 Package to CP-48-5 (Throughout).....	1
Added EPAD Notation to Figure 6.....	10
Updated Outline Dimensions .....	41
Changes to Ordering Guide .....	41

**2/2006—Rev. 0 to Rev. A**

Replaced Figure 40 .....	Page 29
--------------------------	---------

**1/2006—Revision 0: Initial Version**

## GENERAL DESCRIPTION

The [ADF7025](#) is a low power, highly integrated FSK transceiver. It is designed for operation in the license-free ISM bands of 433 MHz, 863 MHz to 870 MHz, and 902 MHz to 928 MHz. The [ADF7025](#) can be used for applications operating under the European ETSI EN300-220 or the North American FCC (Part 15) regulatory standards. The [ADF7025](#) is intended for wideband, high data rate applications with deviation frequencies from 100 kHz to 750 kHz and data rates from 9.6 kbps to 384 kbps. A complete transceiver can be built using a small number of external discrete components, making the [ADF7025](#) very suitable for price-sensitive and area-sensitive applications.

The transmit section contains a VCO and low noise Fractional-N PLL with output resolution of <1 ppm. The VCO operates at twice the fundamental frequency to reduce spurious emissions and frequency pulling problems.

The transmitter output power is programmable in 0.3 dB steps from -16 dBm to +13 dBm. The transceiver RF frequency and modulation are programmable using a simple 3-wire interface. The device operates with a power supply range of 2.3 V to 3.6 V and can be powered down when not in use.

A zero-IF architecture is used in the receiver, minimizing power consumption and the external component count, while avoiding the need for image rejection. The baseband filter (low-pass) has programmable bandwidths of  $\pm 300$  kHz,  $\pm 450$  kHz, and  $\pm 600$  kHz. A high-pass pole at  $\sim 60$  kHz eliminates the problem of dc offsets that is characteristic of zero-IF architecture.

The [ADF7025](#) supports a wide variety of programmable features, including Rx linearity, sensitivity, and filter bandwidth, allowing the user to trade off receiver sensitivity and selectivity against current consumption, depending on the application.

An on-chip ADC provides readback of an integrated temperature sensor, an external analog input, the battery voltage, or the RSSI signal, which provides savings on an ADC in some applications. The temperature sensor is accurate to  $\pm 10^{\circ}\text{C}$  over the full operating temperature range of  $-40^{\circ}\text{C}$  to  $+85^{\circ}\text{C}$ . This accuracy can be improved by doing a 1-point calibration at room temperature and storing the result in memory.

## SPECIFICATIONS

$V_{DD} = 2.3\text{ V}$  to  $3.6\text{ V}$ ,  $GND = 0\text{ V}$ ,  $T_A = T_{MIN}$  to  $T_{MAX}$ , unless otherwise noted. Typical specifications are at  $V_{DD} = 3\text{ V}$ ,  $T_A = 25^\circ\text{C}$ . All measurements are performed using the [EVAL-ADF7025DBZ1](#) using PN9 data sequence, unless otherwise noted.

Table 1.

Parameter	Min	Typ	Max	Unit	Test Conditions
<b>RF CHARACTERISTICS</b>					
Frequency Ranges (Direct Output)	862		870	MHz	VCO adjust = 0, VCO bias = 10
	902		928		VCO adjust = 3, VCO bias = 12
Frequency Ranges (Divide-by-2 Mode)	431		464	MHz	See conditions for direct output
Phase Frequency Detector Frequency	RF/256		24	MHz	
<b>TRANSMISSION PARAMETERS</b>					
Data Rate					
FSK	9.6		384	kbps	
FSK Frequency Deviation	100		311.89	kHz	PFD = 10 MHz, direct output
	100		748.54	kHz	PFD = 24 MHz, direct output
	100		374.27	kHz	PFD = 24 MHz, divide-by-2 mode
Deviation Frequency Resolution	221			Hz	PFD = 3.625 MHz
Gaussian Filter BT		0.5			
Transmit Power <sup>1</sup>	-20		+13	dBm	$V_{DD} = 3.0\text{ V}$ , $T_A = 25^\circ\text{C}$
Transmit Power Variation vs. Temperature		$\pm 1$		dB	From $-40^\circ\text{C}$ to $+85^\circ\text{C}$
Transmit Power Variation vs. $V_{DD}$		$\pm 1$		dB	From 2.3 V to 3.6 V at 915 MHz, $T_A = 25^\circ\text{C}$
Transmit Power Flatness		$\pm 1$		dB	From 902 MHz to 928 MHz, 3 V, $T_A = 25^\circ\text{C}$
Programmable Step Size					
-20 dBm to +13 dBm		0.3125		dB	
Spurious Emissions					
Integer Boundary		-55		dBc	50 kHz loop B/W
Reference		-65		dBc	
Harmonics					
Second Harmonic		-27		dBc	Unfiltered conductive
Third Harmonic		-21		dBc	
All Other Harmonics		-35		dBc	
VCO Frequency Pulling		30		kHz rms	DR = 9.6 kbps
Optimum PA Load Impedance		$39 + j61$		$\Omega$	$F_{RF} = 915\text{ MHz}$
		$48 + j54$		$\Omega$	$F_{RF} = 868\text{ MHz}$
		$54 + j94$		$\Omega$	$F_{RF} = 433\text{ MHz}$
<b>RECEIVER PARAMETERS</b>					
FSK Input Sensitivity					At BER = $1\text{E} - 3$ , $F_{RF} = 915\text{ MHz}$ , LNA and PA matched separately <sup>2</sup>
Sensitivity at 38.4 kbps		-104.2		dBm	$F_{DEV} = 200\text{ kHz}$ , LPF B/W = $\pm 300\text{ kHz}$
Sensitivity at 172.8 kbps		-100		dBm	$F_{DEV} = 200\text{ kHz}$ , LPF B/W = $\pm 450\text{ kHz}$
Sensitivity at 384 kbps		-95.8		dBm	$F_{DEV} = 450\text{ kHz}$ , LPF B/W = $\pm 600\text{ kHz}$
Baseband Filter (Low-Pass) Bandwidths					Programmable
		$\pm 300$		kHz	
		$\pm 450$		kHz	
		$\pm 600$		kHz	
LNA and Mixer, Input IP3					
Enhanced Linearity Mode		+6.8		dBm	$P_{IN} = -20\text{ dBm}$ , 2 CW interferers
Low Current Mode		-3.2		dBm	$F_{RF} = 915\text{ MHz}$ , $f_1 = F_{RF} + 3\text{ MHz}$
High Sensitivity Mode		-35		dBm	$F_2 = F_{RF} + 6\text{ MHz}$ , maximum gain
Rx Spurious Emissions <sup>3</sup>			-57	dBm	<1 GHz at antenna input
			-47	dBm	>1 GHz at antenna input

Parameter	Min	Typ	Max	Unit	Test Conditions
<b>CHANNEL FILTERING</b>					
Adjacent Channel Rejection (Offset = $\pm 1 \times$ LP Filter BW Setting)		27		dB	Desired signal (38.4 kbps DR, 200 kHz $F_{DEV}$ , $\pm 300$ KHz LP filter B/W) 6 dB above the input sensitivity level, CW interferer power level increased until BER = $10^{-3}$
Second Adjacent Channel Rejection (Offset = $\pm 2 \times$ LP Filter BW Setting)		40		dB	
Third Adjacent Channel Rejection (Offset = $\pm 3 \times$ LP Filter BW Setting)		43		dB	
Co-Channel Rejection		-2	+24	dB	Maximum rejection measured with CW interferer at center of channel
Wideband Interference Rejection		70		dB	Swept from 100 MHz to 2 GHz, measured as channel rejection
<b>BLOCKING</b>					
$\pm 1$ MHz		42		dB	Desired signal (38.4 kbps DR, 200 kHz $F_{DEV}$ , $\pm 300$ KHz LP filter B/W) 6 dB above the input sensitivity level, CW interferer power level increased until BER = $10^{-3}$
$\pm 2$ MHz		51		dB	
$\pm 10$ MHz		64		dB	
Saturation (Maximum Input Level)		12		dBm	FSK mode, BER = $10^{-3}$
LNA Input Impedance		24 - j60		$\Omega$	FRF = 915 MHz, RFIN to GND
		26 - j63		$\Omega$	FRF = 868 MHz
		71 - j128		$\Omega$	FRF = 433 MHz
<b>RSSI</b>					
Range at Input		-100 to -36		dBm	
Linearity		$\pm 2$		dB	
Absolute Accuracy		$\pm 3$		dB	
Response Time		150		$\mu$ s	
<b>PHASE-LOCKED LOOP</b>					
VCO Gain		65		MHz/V	902 MHz to 928 MHz band, VCO adjust = 3, VCO_BIAS_SETTING = 12
		83		MHz/V	862 MHz to 870 MHz band, VCO adjust = 0, VCO_BIAS_SETTING = 10
Phase Noise (In-Band)		-89		dBc/Hz	PA = 0 dBm, $V_{DD}$ = 3.0 V, PFD = 10 MHz, FRF = 868 MHz, VCO_BIAS_SETTING = 10
Phase Noise (Out-of-Band)		-110		dBc/Hz	1 MHz offset
Residual FM		128		Hz	From 200 Hz to 20 kHz, $F_{RF}$ = 868 MHz
PLL Settling Time		40		$\mu$ s	Measured for a 10 MHz frequency step to within 5 ppm accuracy, PFD = 20 MHz, LBW = 50 kHz
<b>REFERENCE INPUT</b>					
Crystal Reference	3.625		24	MHz	Using 33 pF load capacitors
External Oscillator	3.625		24	MHz	
Load Capacitance		33		pF	
Crystal Start-Up Time		1.0		ms	
Input Level				CMOS levels	
<b>TIMING INFORMATION</b>					
Chip Enabled to Regulator Ready		10		$\mu$ s	$C_{REG}$ = 100 nF
Crystal Oscillator Startup Time		1		ms	With 19.2 MHz XTAL
Tx to Rx Turnaround Time		150 $\mu$ s + (5 $\times$ $T_{BIT}$ )			Time to synchronized data, includes AGC settling

Parameter	Min	Typ	Max	Unit	Test Conditions	
<b>LOGIC INPUTS</b>						
Input High Voltage, $V_{INH}$	$0.7 \times V_{DD}$			V		
Input Low Voltage, $V_{INL}$			$0.2 \times V_{DD}$	V		
Input Current, $I_{INH}/I_{INL}$			$\pm 1$	$\mu A$		
Input Capacitance, $C_{IN}$			10	pF		
Control Clock Input			50	MHz		
<b>LOGIC OUTPUTS</b>						
Output High Voltage, $V_{OH}$	$DV_{DD} - 0.4$			V	$I_{OH} = 500 \mu A$	
Output Low Voltage, $V_{OL}$			0.4	V	$I_{OL} = 500 \mu A$	
CLK <sub>OUT</sub> Rise/Fall			5	ns		
CLK <sub>OUT</sub> Load			10	pF		
<b>TEMPERATURE RANGE, <math>T_A</math></b>						
	-40		+85	°C		
<b>POWER SUPPLIES</b>						
Voltage Supply						
$V_{DD}$	2.3		3.6	V	All VDD pins must be tied together FRF = 915 MHz, $V_{DD} = 3.0 V$ , PA is matched in to $50 \Omega$	
<b>Transmit Current Consumption</b>						
-20 dBm		14.6		mA		
-10 dBm		15.8		mA		
0 dBm		19.3		mA		
10 dBm		28		mA		
<b>Receive Current Consumption</b>						
Low Current Mode		19		mA		
High Sensitivity Mode		21		mA		
<b>Power-Down Mode</b>						
Low Power Sleep Mode		0.1	1	$\mu A$		

<sup>1</sup> Measured as maximum unmodulated power. Output power varies with both supply and temperature.

<sup>2</sup> Sensitivity for combined matching network case is typically 2 dB less than separate matching networks.

<sup>3</sup> Follow the matching and layout guidelines in the LNA/PA Matching section to achieve the relevant FCC/ETSI specifications.

# TIMING CHARACTERISTICS

$V_{DD} = 3\text{ V} \pm 10\%$ ;  $V_{GND} = 0\text{ V}$ ,  $T_A = 25^\circ\text{C}$ , unless otherwise noted.

Table 2.

Parameter <sup>1</sup>	Limit at $T_{MIN}$ to $T_{MAX}$	Unit	Test Conditions/Comments
$t_1$	<10	ns	SDATA to SCLK setup time
$t_2$	<10	ns	SDATA to SCLK hold time
$t_3$	<25	ns	SCLK high duration
$t_4$	<25	ns	SCLK low duration
$t_5$	<10	ns	SCLK to SLE setup time
$t_6$	<20	ns	SLE pulse width
$t_8$	<25	ns	SCLK to SREAD data valid, readback
$t_9$	<25	ns	SREAD hold time after SCLK, readback
$t_{10}$	<10	ns	SCLK to SLE disable time, readback

<sup>1</sup> Guaranteed by design, not production tested.

## TIMING DIAGRAMS

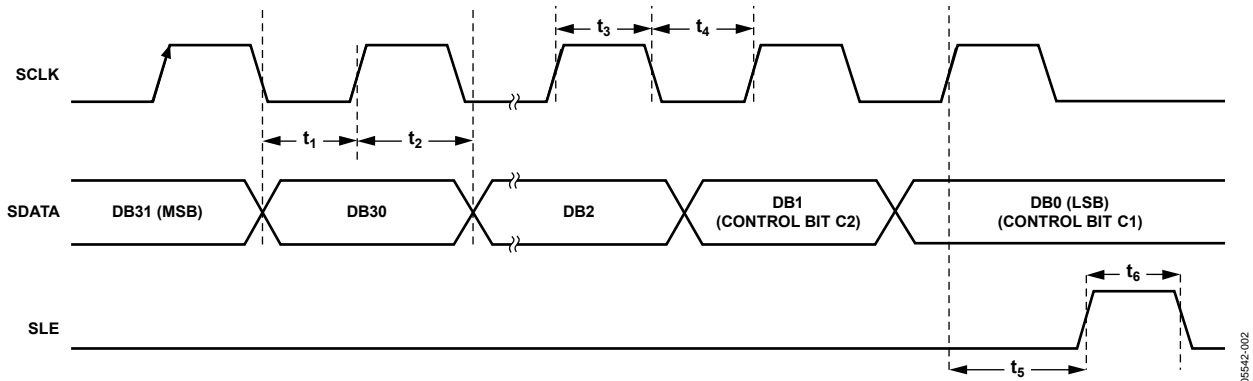

Figure 2. Serial Interface Timing Diagram

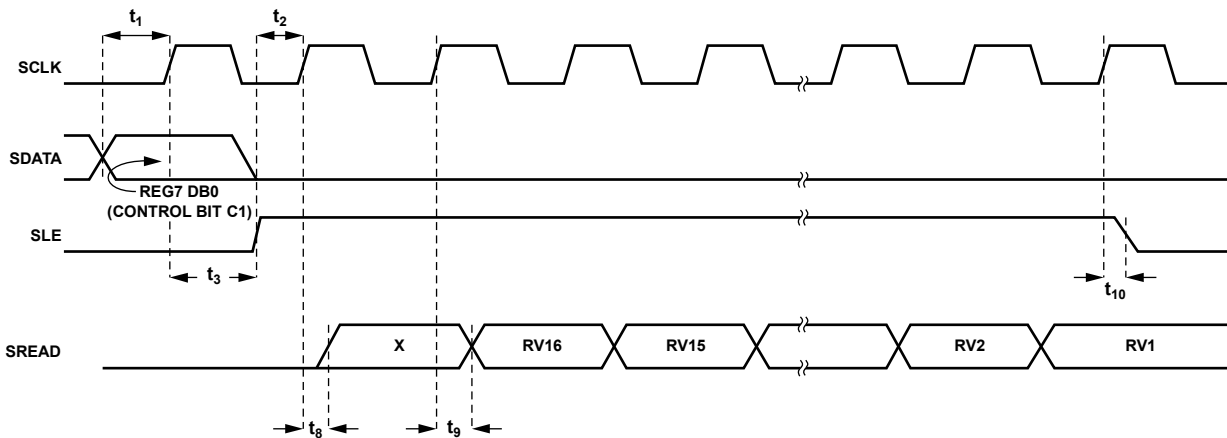

Figure 3. Readback Timing Diagram

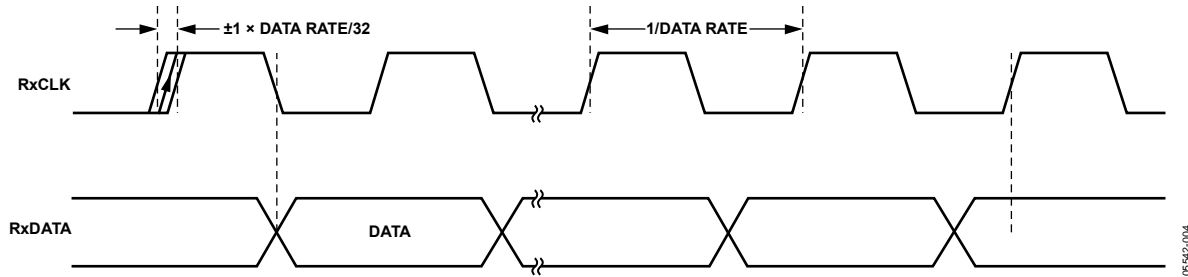

Figure 4. RxData/RxCLK Timing Diagram

06542-004

## ABSOLUTE MAXIMUM RATINGS

$T_A = 25^\circ\text{C}$ , unless otherwise noted.

**Table 3.**

Parameter	Rating
$V_{DD}$ to GND <sup>1</sup>	-0.3 V to +5 V
Analog I/O Voltage to GND	-0.3 V to $AV_{DD} + 0.3$ V
Digital I/O Voltage to GND	-0.3 V to $DV_{DD} + 0.3$ V
Operating Temperature Range	
Industrial (B Version)	-40°C to +85°C
Storage Temperature Range	-65°C to +125°C
Maximum Junction Temperature	125°C
MLF $\theta_{JA}$ Thermal Impedance	26°C/W
Lead Temperature Soldering	
Vapor Phase (60 sec)	235°C
Infrared (15 sec)	240°C

<sup>1</sup> GND = CPGND = RFGND = DGND = AGND = 0 V.

Stresses at or above those listed under Absolute Maximum Ratings may cause permanent damage to the product. This is a stress rating only; functional operation of the product at these or any other conditions above those indicated in the operational section of this specification is not implied. Operation beyond the maximum operating conditions for extended periods may affect product reliability.

This device is a high performance, RF integrated circuit with an ESD rating of <2 kV, and it is ESD sensitive. Proper precautions should be taken for handling and assembly.

### ESD CAUTION



**ESD (electrostatic discharge) sensitive device.** Charged devices and circuit boards can discharge without detection. Although this product features patented or proprietary protection circuitry, damage may occur on devices subjected to high energy ESD. Therefore, proper ESD precautions should be taken to avoid performance degradation or loss of functionality.

# PIN CONFIGURATION AND FUNCTION DESCRIPTIONS

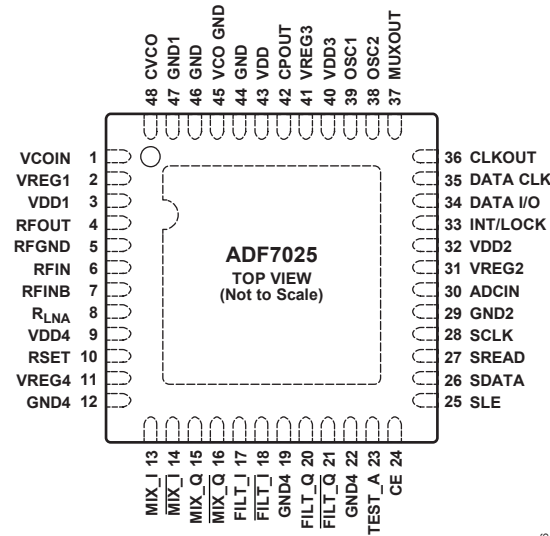

NOTES  
1. CONNECT THE EXPOSED PAD TO GND.

Figure 5. Pin Configuration

Table 4. Pin Function Descriptions

Pin No.	Mnemonic	Description
1	VCOIN	The tuning voltage on this pin determines the output frequency of the voltage-controlled oscillator (VCO). The higher the tuning voltage, the higher the output frequency.
2	VREG1	Regulator Voltage for PA Block. A 100 nF in parallel with a 5.1 pF capacitor should be placed between this pin and ground for regulator stability and noise rejection.
3	VDD1	Voltage Supply for PA Block. Decoupling capacitors of 0.1 μF and 10 pF should be placed as close as possible to this pin. All VDD pins should be tied together.
4	RFOUT	The modulated signal is available at this pin. Output power levels are from -20 dBm to +13 dBm. The output should be impedance-matched to the desired load using suitable components. See the Transmitter section.
5	RFGND	Ground for Output Stage of Transmitter.
6	RFIN	LNA Input for Receiver Section. Input matching is required between the antenna and the differential LNA input to ensure maximum power transfer. See the LNA/PA Matching section.
7	RFINB	Complementary LNA Input. See the LNA/PA Matching section.
8	RLNA	External bias resistor for LNA. Optimum resistor is 1.1 kΩ with 5% tolerance.
9	VDD4	Voltage supply for LNA/MIXER Block. This pin should be decoupled to ground with a 10 nF capacitor.
10	RSET	External Resistor to Set Charge Pump Current and Some Internal Bias Currents. Use 3.6 kΩ with 5% tolerance.
11	VREG4	Regulator Voltage for LNA/MIXER Block. A 100 nF capacitor should be placed between this pin and GND for regulator stability and noise rejection.
12	GND4	Ground for LNA/MIXER Block.
13 to 18	MIX/FILT	Signal Chain Test Pins. These pins are high impedance under normal conditions and should be left unconnected.
19, 22	GND4	Ground for LNA/MIXER Block.
20, 21, 23	FILT/TEST_A	Signal Chain Test Pins. These pins are high impedance under normal conditions and should be left unconnected.
24	CE	Chip Enable. Bringing CE low puts the ADF7025 into complete power-down. Register values are lost when CE is low, and the part must be reprogrammed once CE is brought high.
25	SLE	Load Enable, CMOS Input. When LE goes high, the data stored in the shift registers is loaded into one of the four latches. A latch is selected using the control bits.
26	SDATA	Serial Data Input. The serial data is loaded MSB first with the two LSBs as the control bits. This pin is a high impedance CMOS input.
27	SREAD	Serial Data Output. This pin is used to feed readback data from the ADF7025 to the microcontroller. The SCLK input is used to clock each readback bit (ADC readback) from the SREAD pin.
28	SCLK	Serial Clock Input. This serial clock is used to clock in the serial data to the registers. The data is latched into the 24-bit shift register on the CLK rising edge. This pin is a digital CMOS input.

Pin No.	Mnemonic	Description
29	GND2	Ground for Digital Section.
30	ADCIN	Analog-to-Digital Converter Input. The internal 7-bit ADC can be accessed through this pin. Full scale is 0 V to 1.9 V. Readback is made using the SREAD pin.
31	VREG2	Regulator Voltage for Digital Block. A 100 nF in parallel with a 5.1 pF capacitor should be placed between this pin and ground for regulator stability and noise rejection.
32	VDD2	Voltage Supply for Digital Block. A decoupling capacitor of 10 nF should be placed as close as possible to this pin.
33	INT/LOCK	Bidirectional Pin. In output mode (interrupt mode), the ADF7025 asserts the INT/LOCK pin when it has found a match for the preamble sequence. In input mode (lock mode), the microcontroller can be used to lock the demodulator threshold when a valid preamble has been detected. Once the threshold is locked, NRZ data can be reliably received. In this mode, a demodulator lock can be asserted with minimum delay.
34	DATA I/O	Transmit Data Input/Received Data Output. This is a digital pin, and normal CMOS levels apply.
35	DATA CLK	In receive mode, the pin outputs the synchronized data clock. The positive clock edge is matched to the center of the received data.
36	CLKOUT	A Divided-Down Version of the Crystal Reference with Output Driver. The digital clock output can be used to drive several other CMOS inputs, such as a microcontroller clock. The output has a 50:50 mark-space ratio.
37	MUXOUT	This pin provides the LOCK_DETECT signal, which is used to determine if the PLL is locked to the correct frequency. Other signals include REGULATOR_READY, which is an indicator of the status of the serial interface regulator.
38	OSC2	The reference crystal should be connected between this pin and OSC1. A TCXO reference can be used by driving this pin with CMOS levels and disabling the crystal oscillator.
39	OSC1	The reference crystal should be connected between this pin and OSC2.
40	VDD3	Voltage Supply for the Charge Pump and PLL Dividers. This pin should be decoupled to ground with a 0.01 $\mu$ F capacitor.
41	VREG3	Regulator Voltage for Charge Pump and PLL Dividers. A 100 nF in parallel with a 5.1 pF capacitor should be placed between this pin and ground for regulator stability and noise rejection.
42	CPOUT	Charge Pump Output. This output generates current pulses that are integrated in the loop filter. The integrated current changes the control voltage on the input to the VCO.
43	VDD	Voltage Supply for VCO Tank Circuit. This pin should be decoupled to ground with a 0.01 $\mu$ F capacitor.
44 to 47	GND	Grounds for VCO Block.
48	CVCO	A 22 nF capacitor should be placed between this pin and VREG1 to reduce VCO noise.
	EPAD	Exposed Pad. Connect the exposed pad to GND.

TYPICAL PERFORMANCE CHARACTERISTICS

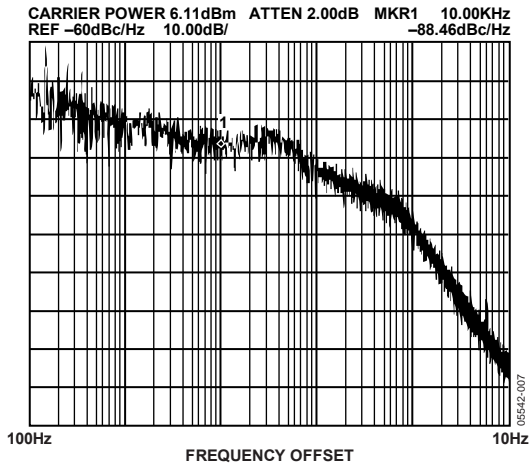

Figure 6. Phase Noise Response at 915 MHz,  $V_{DD} = 3.0V$ ,  $ICP = 0.867mA$

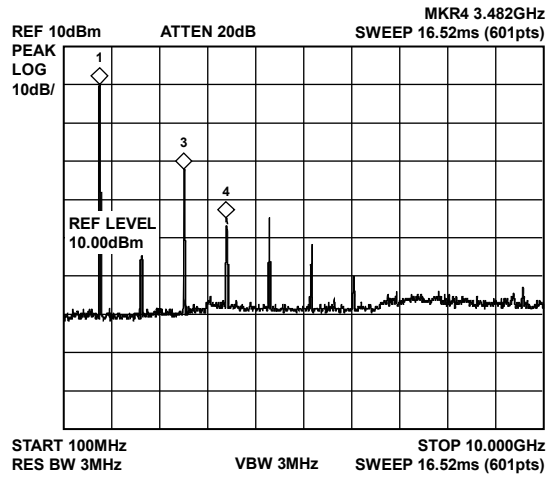

Figure 9. Harmonic Response, RFOUT Matched to 50  $\Omega$ , No Filter

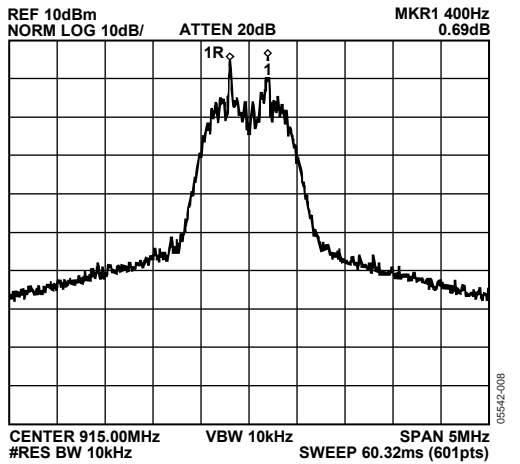

Figure 7. Output Spectrum in FSK Modulation (915 MHz, 172.8 kbps Data Rate, 200 kHz Frequency Deviation)

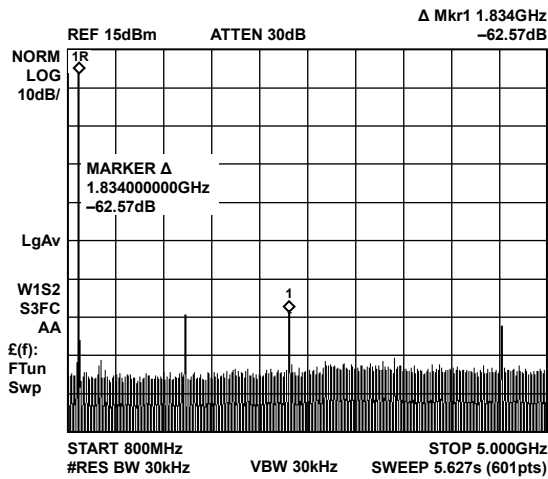

Figure 10. Harmonic Response, Murata Dielectric Filter

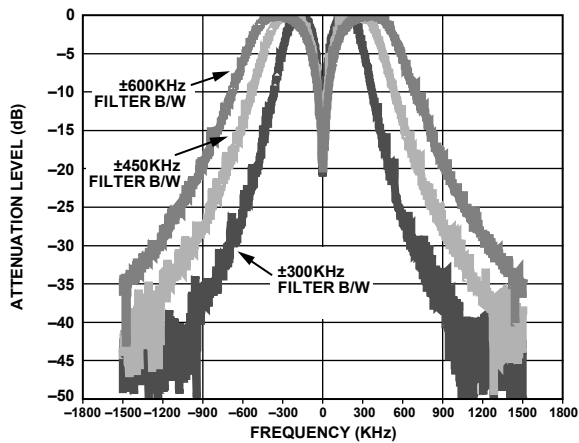

Figure 8. Baseband Filter Response

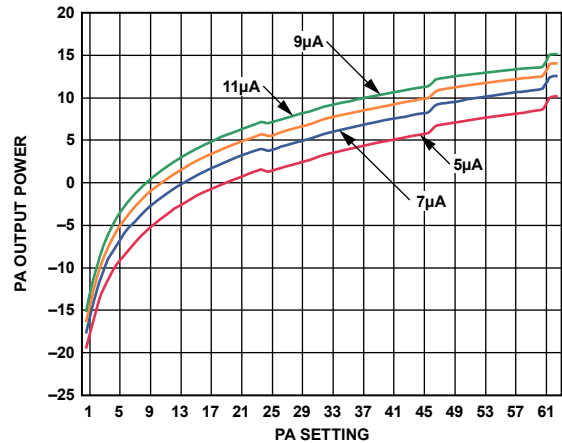

Figure 11. PA Output Power vs. Setting

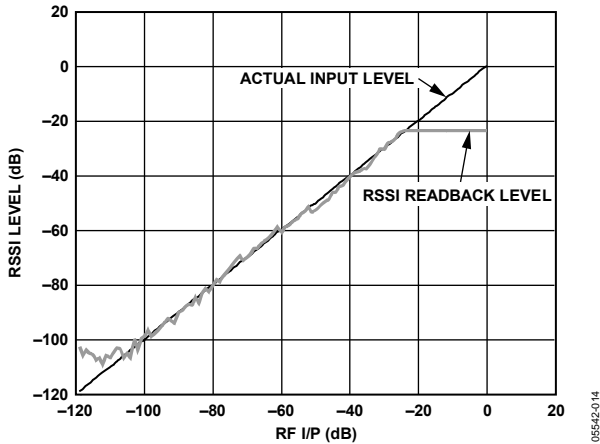

Figure 12. Digital RSSI Readback

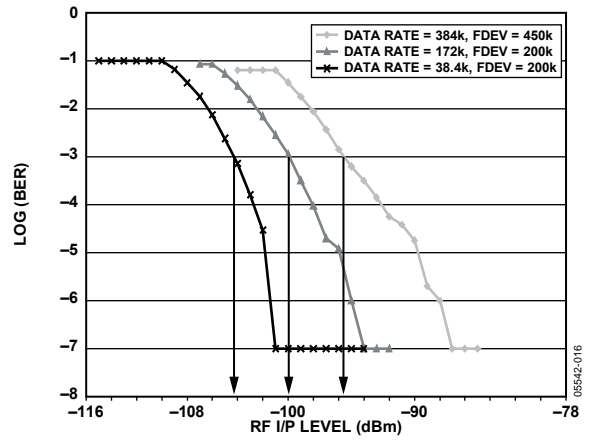

Figure 15. BER vs. Data Rate (Combined Matching Network)

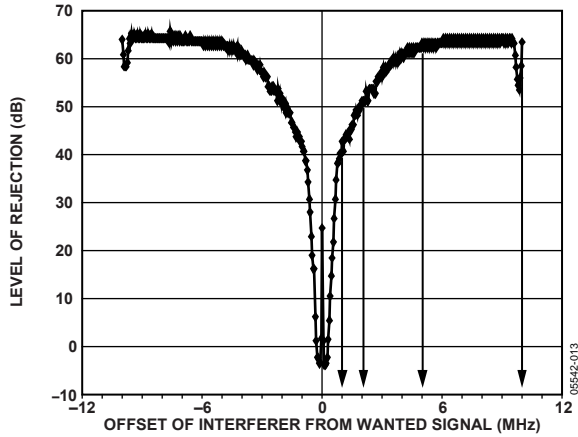

Figure 13. Wideband Interference Rejection; Wanted Signal (901 MHz, 38.4 kbps Data Rate, 200 kHz Frequency Deviation) at 6 dB Above Sensitivity Point; Interferer = CW Jammer

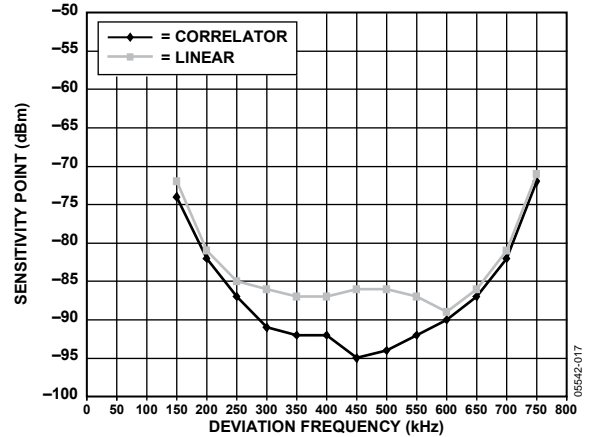

Figure 16. Sensitivity vs. Mod Index (Data Rate = 384 kbps, Baseband Filter Bandwidth = ±600 kHz), for Both Demodulator Types

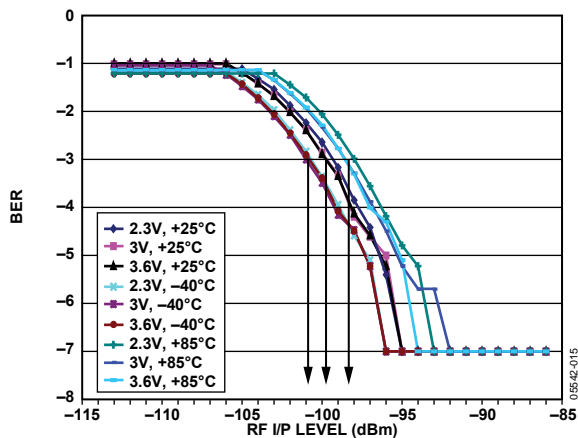

Figure 14. Sensitivity vs.  $V_{DD}$  and Temperature (172.8 kbps Data Rate, 200 kHz Frequency Deviation, Baseband Bandwidth ±600 kHz)

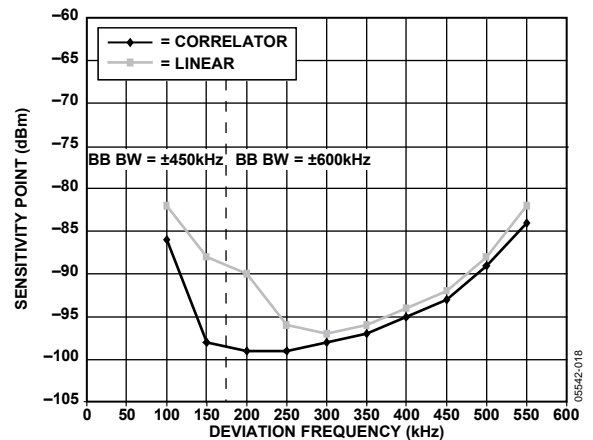

Figure 17. Sensitivity vs. Mod Index (Data Rate = 172.8 kbps), for Both Demodulator Types

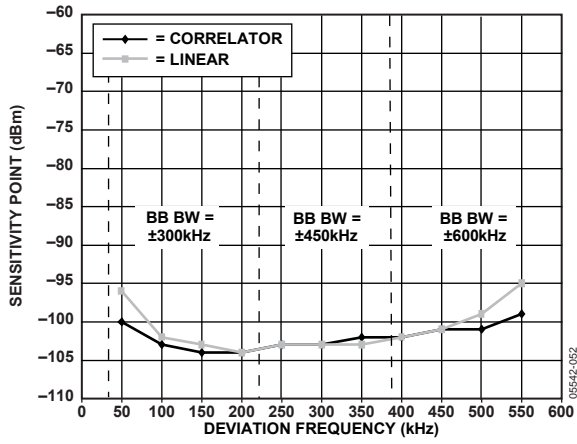

Figure 18. Sensitivity vs. Mod Index (Data Rate = 38.4 kbps), for both Demodulator Types

# FREQUENCY SYNTHESIZER

## REFERENCE INPUT SECTION

The on-board crystal oscillator circuitry (see Figure 19) can use an inexpensive quartz crystal as the PLL reference. The oscillator circuit is enabled by setting R1\_DB12 high. It is enabled by default on power-up and is disabled by bringing CE low. Errors in the crystal can be corrected by adjusting the Fractional-N value (see the N Counter section). A single-ended reference (TCXO, CXO) can also be used. The CMOS levels should be applied to OSC2 with R1\_DB12 set low.

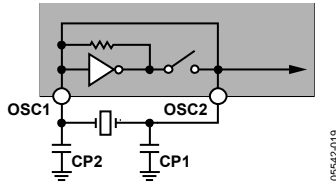

Figure 19. Oscillator Circuit on the ADF7025

Two parallel resonant capacitors are required for oscillation at the correct frequency; their values are dependent on the crystal specification. They should be chosen so that the series value of capacitance added to the PCB track capacitance adds up to the load capacitance of the crystal, usually 20 pF. Track capacitance values vary from 2 pF to 5 pF, depending on board layout. Where possible, choose capacitors that have a very low temperature coefficient to ensure stable frequency operation over all conditions.

## CLKOUT Divider and Buffer

The CLKOUT circuit takes the reference clock signal from the oscillator section, shown in Figure 20, and supplies a divided-down 50:50 mark-space signal to the CLKOUT pin. An even divide from 2 to 30 is available. This divide number is set in R1\_DB[8:11]. On power-up, the CLKOUT defaults to divide-by-8.

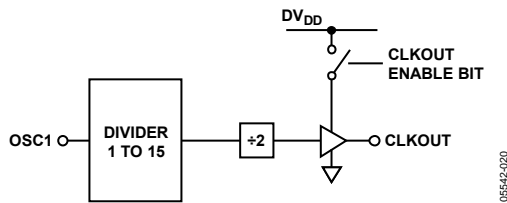

Figure 20. CLKOUT Stage

To disable CLKOUT, set the divide number to 0. The output buffer can drive up to a 20 pF load with a 10% rise time at 4.8 MHz. Faster edges can result in some spurious feedthrough to the output. A small series resistor (50 Ω) can be used to slow the clock edges to reduce these spurs at F<sub>CLK</sub>.

## R Counter

The 3-bit R counter divides the reference input frequency by an integer from 1 to 7. The divided-down signal is presented as the reference clock to the phase frequency detector (PFD). The divide ratio is set in Register 1. Maximizing the PFD frequency reduces the N value. This reduces the noise multiplied at a rate of 20 log(N) to the output, as well as reducing occurrences of spurious components. The R register defaults to R = 1 on power-up.

$$PFD [Hz] = XTAL/R$$

## MUXOUT and Lock Detect

The MUXOUT pin allows the user to access various digital points in the ADF7025. The state of MUXOUT is controlled by Bits R0\_DB[29:31].

## Regulator Ready

Regulator ready is the default setting on MUXOUT after the transceiver has been powered up. The power-up time of the regulator is typically 50 μs. Because the serial interface is powered from the regulator, the regulator must be at its nominal voltage before the ADF7025 can be programmed. The status of the regulator can be monitored at MUXOUT. When the regulator ready signal on MUXOUT is high, programming of the ADF7025 can begin.

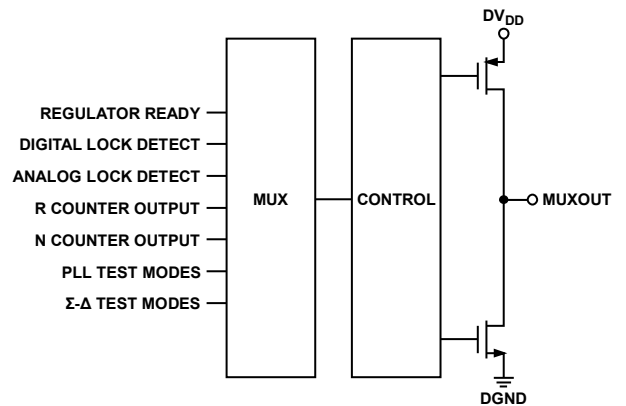

Figure 21. MUXOUT Circuit

## Digital Lock Detect

Digital lock detect is active high. The lock detect circuit is located at the PFD. When the phase error on five consecutive cycles is less than 15 ns, lock detect is set high. Lock detect remains high until a 25 ns phase error is detected at the PFD. Because no external components are needed for digital lock detect, it is more widely used than analog lock detect.

**Analog Lock Detect**

This N-channel open-drain lock detect should be operated with an external pull-up resistor of 10 kΩ nominal. When a lock has been detected, this output is high with narrow low-going pulses.

**Voltage Regulators**

The ADF7025 contains four regulators to supply stable voltages to the part. The nominal regulator voltage is 2.3 V. Each regulator should have a 100 nF capacitor connected between VREG and GND. When CE is high, the regulators and other associated circuitry are powered on, drawing a total supply current of 2 mA. Bringing the chip-enable pin low disables the regulators, reduces the supply current to less than 1 μA, and erases all values held in the registers. The serial interface operates from a regulator supply; therefore, to write to the part, the user must have CE high and the regulator voltage must be stabilized. Regulator status (VREG4) can be monitored using the regulator ready signal from MUXOUT.

**Loop Filter**

The loop filter integrates the current pulses from the charge pump to form a voltage that tunes the output of the VCO to the desired frequency. It also attenuates spurious levels generated by the PLL. A typical loop filter design is shown in Figure 22.

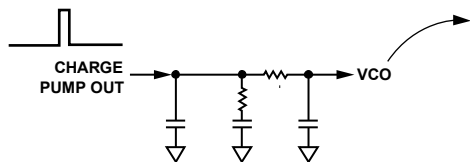

Figure 22. Typical Loop Filter Configuration

In general, a loop filter bandwidth (LBW) of between the data rate and twice the data rate is recommended. Widening the LBW excessively reduces the time spent jumping between frequencies, but it can cause insufficient spurious attenuation. Narrow-loop bandwidths can result in the loop taking long periods of time to attain lock. For the ADF7025 in receive mode, the loop filter bandwidth affects the close-in blocking performance. The narrower the bandwidth of the loop filter, the greater the close-in interference resilience of the receiver.

Careful design of the loop filter is critical to obtaining accurate FSK modulation. The free design tool ADIsimPLL can be used to design loop filters for the ADF7025.

**N Counter**

The feedback divider in the ADF7025 PLL consists of an 8-bit integer counter and a 14-bit Σ-Δ Fractional-N divider. The integer counter is the standard pulse-swallow type common in PLLs. This sets the minimum integer divide value to 31.

The fractional divide value gives very fine resolution at the output, where the output frequency of the PLL is calculated as

$$F_{OUT} = \frac{XTAL}{R} \times \left( Integer\ N + \frac{Fractional\ N}{2^{15}} \right)$$

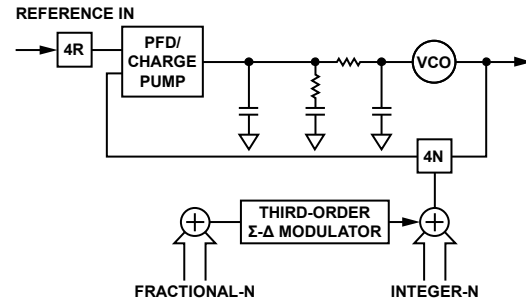

Figure 23. Fractional-N PLL

The combination of the Integer-N (maximum = 255) and the Fractional-N (maximum = 16383/16384) gives a maximum N divider of 255 + 1. Therefore, the minimum usable PFD is

$$PDF_{MIN} [Hz] = \text{Maximum Required Output Frequency} / (255 + 1)$$

For example, when operating in the European 868 MHz to 870 MHz band, PDF<sub>MIN</sub> equals 3.4 MHz.

**Voltage Controlled Oscillator**

To minimize spurious emissions, the on-chip VCO operates from 1732 MHz to 1856 MHz. The VCO signal is then divided by 2 to give the required frequency for the transmitter and the required LO frequency for the receiver.

The VCO should be re-centered, depending on the required frequency of operation, by programming the VCO adjust bits R1\_DB[20:21].

For operation in the 862 MHz to 870 MHz band, it is recommended to use a VCO bias of at least Setting 10 and to set the VCO adjust bit to Setting 0. For operation in the 902 MHz to 928 MHz band, it is recommended to use a VCO bias of at least Setting 12 and to set the VCO adjust bit to Setting 3. This is to ensure correct operation under all conditions.

The VCO is enabled as part of the PLL by the PLL-enable bit, R0\_DB28.

An additional frequency divide-by-2 is included to allow operation in the lower 431 MHz to 464 MHz bands. To enable operation in these bands, R1\_DB13 should be set to 1. The VCO needs an external 22 nF between the VCO and the regulator to reduce internal noise.

### VCO Bias Current

VCO bias current can be adjusted using Bit R1\_DB19 to Bit R1\_DB16. To ensure VCO oscillation under all conditions, the minimum bias current setting is Setting 12 (0xC).

### 431 MHz to 464 MHz Operation

For operation in the 431 MHz to 464 MHz band, the frequency divide-by-2 has to be enabled. It is enabled by R1\_DB13. Because this divide is external to the synthesizer loop, the feedback divider number ( $N + F$ ) should be programmed to a value twice the desired RF output frequency.

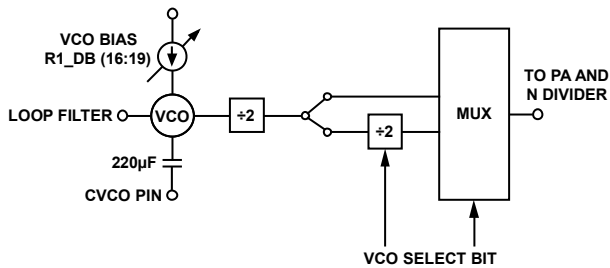

Figure 24. Voltage Controlled Oscillator

05542-024

### CHOOSING CHANNELS FOR BEST SYSTEM PERFORMANCE

The Fractional-N PLL allows the selection of any channel within 862 MHz to 928 MHz (and 431 MHz to 464 MHz using divide-by-2) to a resolution of <300 Hz. This also facilitates frequency-hopping systems.

Careful selection of the RF transmit channels must be made to achieve best spurious performance. The architecture of fractional-N results in some level of the nearest integer channel moving through the loop to the RF output. These beat-note spurs are not attenuated by the loop, if the desired RF channel and the nearest integer channel are separated by a frequency of less than the LBW.

The occurrence of beat-note spurs is rare, because the integer frequencies are at multiples of the reference, which is typically >10 MHz.

Beat-note spurs can be significantly reduced in amplitude by avoiding very small or very large values in the fractional register, using the frequency doubler. By having a channel 1 MHz away from an integer frequency, a 100 kHz loop filter can reduce the level to less than -45 dBc.

## TRANSMITTER

### RF OUTPUT STAGE

The PA of the ADF7025 is based on a single-ended, controlled current, open-drain amplifier that has been designed to deliver up to 13 dBm into a 50 Ω load at a maximum frequency of 928 MHz.

The PA output current and, consequently, the output power are programmable over a wide range. The PA configuration is shown in Figure 25. The output power is independent of the state of the DATA I/O pin. The output power is set using Bits R2\_DB[9:14].

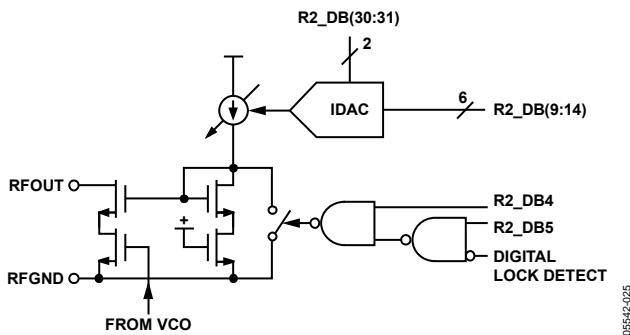

Figure 25. PA Configuration

The PA is equipped with overvoltage protection, which makes it robust in severe mismatch conditions. Depending on the application, one can design a matching network for the PA to exhibit optimum efficiency at the desired radiated output power level for a wide range of different antennas, such as loop or monopole antennas. See the LNA/PA Matching section for details.

### PA Bias Currents

Control Bits R2\_DB [30:31] facilitate an adjustment of the PA bias current to further extend the output power control range, if necessary. If this feature is not required, the default value of 7 μA is recommended. The output stage is powered down by resetting Bit R2\_DB4.

### MODULATION SCHEME

#### Frequency Shift Keying (FSK)

Frequency shift keying is implemented by setting the N value for the center frequency and then toggling this with the TxData line. The deviation from the center frequency is set using Bits R2\_DB[15:23]. The deviation from the center frequency in Hz is

$$FSK_{DEVIATION} [Hz] = \frac{PFD \times Modulation\ Number}{2^{14}}$$

where *Modulation Number* is a number from 1 to 511 (R2\_DB(15:23)).

Select FSK using Bits R2\_DB[6:8].

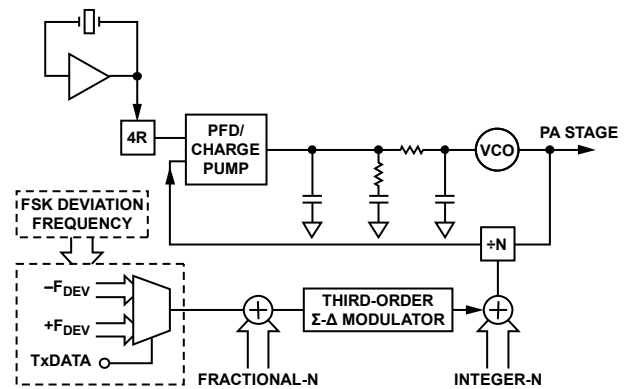

Figure 26. FSK Implementation

#### Modulation Index

The choice of deviation frequency for a given data rate is critical to get optimum sensitivity performance from the ADF7025. The modulation index (MI) of an FSK modulated signal is defined as

$$MI = \frac{2 \times Frequency\ Deviation [Hz]}{Data\ Rate [bps]}$$

It is recommended to use a MI > 1 for the ADF7025. The variation of receiver sensitivity with modulation index, for various data rates, can be observed in Figure 16, Figure 17, and Figure 18.

## RECEIVER

### RF FRONT END

The ADF7025 is based on a fully integrated, zero-IF receiver architecture. The zero-IF architecture minimizes power consumption and the external component count while avoiding the need for image rejection.

Figure 27 shows the structure of the receiver front end. The numerous programming options allow users to trade off sensitivity, linearity, and current consumption against each other in the way best suitable for their applications. To achieve a high level of resilience against spurious reception, the LNA features a differential input. Switch SW2 shorts the LNA input when transmit mode is selected ( $R0\_DB27 = 0$ ). This feature facilitates the design of a combined LNA/PA matching network, avoiding the need for an external Rx/Tx switch. See the LNA/PA Matching section for details on the design of the matching network.

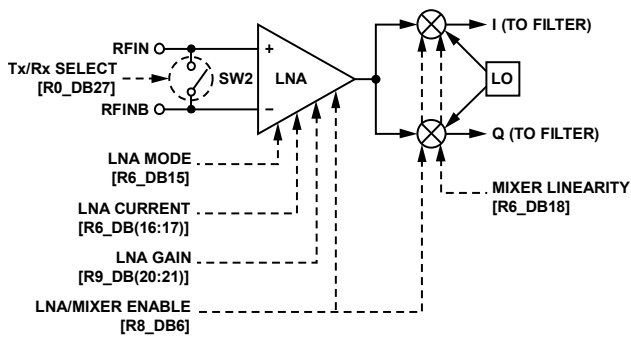

Figure 27. ADF7025 RF Front End

The LNA is followed by a quadrature downconversion mixer, which converts the RF signal direct to baseband. The output frequency of the synthesizer must be programmed to the value equal to the center frequency of the received channel.

The LNA has two basic operating modes: high gain/low noise mode and low gain/low power mode. To switch between the two modes, use the LNA\_MODE bit, R6\_DB15. The mixer is also configurable between a low current and an enhanced linearity mode using the MIXER\_LINEARITY bit, R6\_DB18.

Based on the specific sensitivity and linearity requirements of the application, it is recommended to adjust control bits LNA\_MODE (R6\_DB15) and MIXER\_LINEARITY (R6\_DB18).

The gain of the LNA is configured by the LNA\_GAIN field, R9\_DB[20:21] and can be set by either the user or the automatic gain control (AGC) logic.

#### Filter Settings/Calibration

Out-of-band interference is rejected by means of a fifth-order, low-pass filter (LPF). The bandwidth of the filter can be programmed to be  $\pm 300$  kHz,  $\pm 450$  kHz, or  $\pm 600$  kHz by means of Control Bits R1\_DB[22:23] and should be chosen as a compromise between interference rejection and attenuation of the desired signal. A high-pass filter is also included as part of the low-pass filter to prevent against dc offset problems. The bandwidth of this filter is  $\sim 60$  kHz. To avoid significant loss of FSK modulated signal in the filter, the frequency deviation needs to be significantly larger than this pole (refer to the Modulation Index section). The minimum allowable frequency deviation is 100 kHz.

To compensate for manufacturing tolerances, the LPF should be calibrated once after power-up. The LPF calibration logic requires that the LPF divider in Bits R6\_DB[20:28] be set depending on the crystal frequency. Once initiated by setting Bit R6\_DB19, the calibration is performed automatically without any user intervention. The calibration time is 200  $\mu$ s, during which the ADF7025 should not be accessed. It is important not to initiate the calibration cycle before the crystal oscillator has fully settled. If the AGC loop is disabled, the gain of LPF can be set to three levels using the FILTER\_GAIN field, R9\_DB[20:21]. The filter gain is adjusted automatically, if the AGC loop is enabled.

**RSSI/AGC**

The RSSI is implemented as a successive compression log amp following the baseband channel filtering. The log amp achieves ±3 dB log linearity. It also doubles as a limiter to convert the signal-to-digital levels for the FSK demodulator. Offset correction is achieved using a switched capacitor integrator in feedback around the log amp. This uses the BB offset clock divide. The RSSI level is converted for user readback and digitally controlled AGC by an 80-level (7-bit) flash ADC. This level can be converted to input power in dBm.

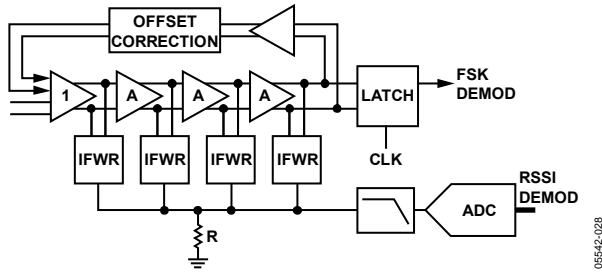

Figure 28. RSSI Block Diagram

**Offset Correction Clock**

In Register 3, the user should set the BB offset clock divide bits R3\_DB[4:5] to give an offset clock between 1 MHz and 2 MHz, where  $BBOS\_CLK [Hz] = XTAL / (BBOS\_CLK\_DIVIDE)$ .

BBOS\_CLK\_DIVIDE can be set to 4, 8, or 16.

**AGC Information**

In Register 9, the user should select automatic gain control by selecting Auto In R9\_DB18 and Auto In R9\_DB19. The user should then program AGC Low Threshold R9\_DB[4:10] and AGC High Threshold R9\_DB[11:17]. The default values for the low and high thresholds are 30 and 70, respectively; however, these are not the optimum settings for all operating conditions. The recommended values for the low and high thresholds are 15 and 79, respectively. In the AGC 2 register (Register 10), the user should program the AGC delay to be long enough to allow the loop to settle. The default/recommended value is 10.

$$AGC\_WAIT\_TIME = \frac{AGC\_DELAY \times SEQ\_CLK\_DIVIDE}{XTAL}$$

$$AGC\ Settling = AGC\_WAIT\_TIME \times \text{Number of Gain Changes}$$

Thus, in the worst case, if the AGC loop has to go through all five gain changes, AGC delay = 10, and SEQ\_CLK = 200 kHz, then AGC settling =  $10 \times 5 \mu s \times 5 = 250 \mu s$ . Minimum AGC\_WAIT\_TIME must be at least 25 μs.

**RSSI Formula (Converting to dBm)**

$$INPUT\_POWER [dBm] = -98\text{ dBm} + (READBACK\_CODE + GAIN\_MODE\_CORRECTION) \times 0.5$$

where:

READBACK\_CODE is given by Bit RV7 to Bit RV1 in the readback register (see the Readback Format section).

GAIN\_MODE\_CORRECTION is given by the values in Table 5.

LNA gain and filter gain (LG2/LG1, FG2/FG1) are also obtained from the readback register.

Table 5. Gain Mode Correction

LNA Gain (LG2, LG1)	Filter Gain (FG2, FG1)	Gain Mode Correction
H (11)	H (10)	0
M (10)	H (10)	17
M (10)	M (01)	53
M (10)	L (00)	65
L (01)	L (00)	90
EL (00)	L (00)	113

These numbers are for an unmodulated tone. For a modulated signal, the RSSI readback may have to be adjusted to get the required accuracy. An additional factor should also be introduced to account for losses in the front-end matching network/antenna.

**FSK DEMODULATORS ON THE ADF7025**

The two FSK demodulators on the ADF7025 are

- FSK correlator/demodulator
- Linear demodulator

Select these using the Demod Select Bits R4\_DB[4:5].

**FSK CORRELATOR/DEMODULATOR**

The quadrature outputs of the IF filter are first limited and then fed to a pair of digital frequency correlators that perform band-pass filtering of the binary FSK frequencies at  $(IF + F_{DEV})$  and  $(IF - F_{DEV})$ . Data is recovered by comparing the output levels from each of the two correlators. The performance of this frequency discriminator approximates that of a matched filter detector, which is known to provide optimum detection in the presence of AWGN.

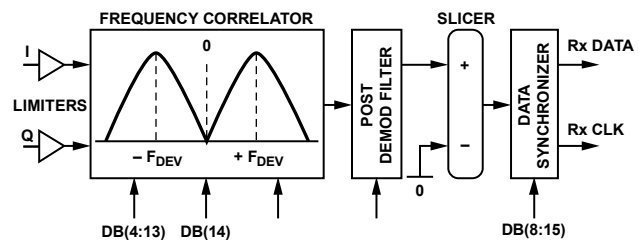

Figure 29. FSK Correlator/Demodulator Block Diagram

**Postdemodulator Filter**

A second-order, digital low-pass filter removes excess noise from the demodulated bit stream at the output of the discriminator. The bandwidth of this postdemodulator filter is programmable and must be optimized for the user's data rate. If the bandwidth is set too narrow, performance is degraded due to intersymbol interference (ISI). If the bandwidth is set too wide, excess noise degrades the receiver's performance. Typically, the 3 dB bandwidth of this filter is set at approximately 0.75 times the user's data rate, using Bits R4\_DB[6:15].

**Bit Slicer**

The received data is recovered by the threshold detecting the output of the postdemodulator low-pass filter. In the correlator/demodulator, the binary output signal levels of the frequency discriminator are always centered on 0. Therefore, the slicer threshold level can be fixed at 0, and the demodulator performance is independent of the run-length constraints of the transmit data bit stream. This results in robust data recovery, which does not suffer from the classic baseline wander problems that exist in more traditional FSK demodulators.

**Data Synchronizer**

An oversampled digital PLL is used to resynchronize the received bit stream to a local clock. The oversampled clock rate of the PLL (CDR\_CLK) must be set at 32 times the data rate. See the Register 3—Receiver Clock Register section for a definition of how to program. The clock recovery PLL can accommodate frequency errors of up to  $\pm 2\%$ .

**FSK Correlator Register Settings**

To enable the FSK correlator/demodulator, Bits R4\_DB[5:4] should be set to 01. To achieve best performance, the bandwidth of the FSK correlator must be optimized for the specific deviation frequency that is used by the FSK transmitter.

The discriminator BW is controlled in Register 6 by R6\_DB[4:13] and is defined as

$$DISCRIMINATOR\_BW = DEMOD\_CLK / (4 \times F_{DEV})$$

where:

$DEMOD\_CLK$  is as defined in the Register 3—Receiver Clock Register section.

$F_{DEV}$  is the deviation from the carrier frequency in FSK modulation.

**Postdemodulator Bandwidth Register Settings**

The 3 dB bandwidth of the postdemodulator filter is controlled by Bits R4\_DB[6:15] and is given by

$$POST\_DEMOD\_BW\_SETTING = \frac{2^{10} \times 2\pi \times F_{CUTOFF}}{DEMOD\_CLK}$$

where  $F_{CUTOFF}$  is the target 3 dB bandwidth in Hz of the postdemodulator filter. This should typically be set to 0.75 times the data rate (DR).

Some sample settings for the FSK correlator/demodulator are

$$DEMOD\_CLK = 11.0592 \text{ MHz}$$

$$DR = 200 \text{ kbps}$$

$$F_{DEV} = 300 \text{ kHz}$$

Therefore,

$$F_{CUTOFF} = 0.75 \times 200 \times 10^3 \text{ Hz}$$

$$POST\_DEMOD\_BW = 2^{11} \times \pi \times 150 \times 10^3 \text{ Hz} / (11.0592 \text{ MHz})$$

$$POST\_DEMOD\_BW = \text{Round}(87.266) = 87$$

and

$$DISCRIMINATOR\_BW = (11.0592 \text{ MHz}) / (4 \times 300 \times 10^3) = 9.21 = 9 \text{ (rounded to the nearest integer)}$$

**Table 6. Register Settings**

Setting Name	Register Address	Value
POST_DEMOD_BW	R4_DB[6:15]	0x09
DISCRIMINATOR_BW	R6_DB[4:13]	0x58

**LINEAR FSK DEMODULATOR**

A block diagram of the linear FSK demodulator is shown in Figure 30.

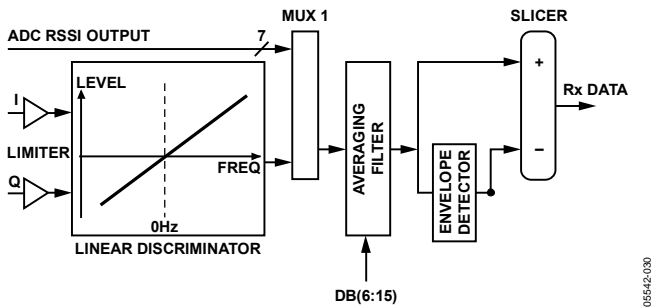

Figure 30. Block Diagram of Linear FSK Demodulator

This method of frequency demodulation is useful when very short preamble length is required.

A digital frequency discriminator provides an output signal that is linearly proportional to the frequency of the limiter outputs. The discriminator output is then filtered and averaged using a combined averaging filter and envelope detector. The demodulated FSK data is recovered by threshold-detecting the output of the averaging filter, as shown in Figure 30. In this mode, the slicer output shown in Figure 30 is routed to the data synchronizer PLL for clock synchronization. To enable the linear FSK demodulator, Bits R4\_DB[4:5] are set to [00].

The 3 dB bandwidth of the postdemodulation filter is set in the same way as the FSK correlator/demodulator, which is set in R4\_DB[6:15] and is defined as

$$POST\_DEMOD\_BW\_SETTING = \frac{2^{10} \times 2\pi \times F_{CUTOFF}}{DEMOD\_CLK}$$

where:

$F_{CUTOFF}$  is the target 3 dB bandwidth in Hz of the postdemodulator filter.

$DEMOD\_CLK$  is as defined in the Register 3—Receiver Clock Register section.

**AUTOMATIC SYNC WORD RECOGNITION**

The ADF7025 also supports automatic detection of the sync or ID fields. To activate this mode, the sync (or ID) word must be preprogrammed into the ADF7025. In receive mode, this preprogrammed word is compared to the received bit stream and, when a valid match is identified, the external pin INT/LOCK is asserted by the ADF7025.

This feature can be used to alert the microprocessor that a valid channel has been detected. It relaxes the computational requirements of the microprocessor and reduces the overall power consumption. The INT/LOCK is automatically de-asserted again after nine data clock cycles.

The automatic sync/ID word detection feature is enabled by selecting Demod Mode 2 or Demod Mode 3 in the demodulator setup register. Do this by setting R4\_DB[25:23] = [010] or R4\_DB[25:23] = [011]. Bits R5\_DB[4:5] are used to set the length of the sync/ID word, which can be either 12 bits, 16 bits, 20 bits, or 24 bits long. The transmitter must transmit the MSB of the sync byte first and the LSB last to ensure proper alignment in the receiver sync byte detection hardware.

For systems using FEC, an error tolerance parameter can also be programmed that accepts a valid match when up to three bits of the word are incorrect. The error tolerance value is assigned in R5\_DB[6:7].

## APPLICATIONS SECTION

### LNA/PA MATCHING

The ADF7025 exhibits optimum performance in terms of sensitivity, transmit power, and current consumption only if its RF input and output ports are properly matched to the antenna impedance. For cost-sensitive applications, the ADF7025 is equipped with an internal Rx/Tx switch, which facilitates the use of a simple combined passive PA/LNA matching network. Alternatively, an external Rx/Tx switch, such as the Analog Devices ADG919, can be used, which yields a slightly improved receiver sensitivity and lower transmitter power consumption.

#### External Rx/Tx Switch

Figure 31 shows a configuration using an external Rx/Tx switch. This configuration allows an independent optimization of the matching and filter network in the transmit and receive path, and is, therefore, more flexible and less difficult to design than the configuration using the internal Rx/Tx switch. The PA is biased through Inductor L1, while C1 blocks dc current. Both elements, L1 and C1, also form the matching network, which transforms the source impedance into the optimum PA load impedance,  $Z_{OPT\_PA}$ .

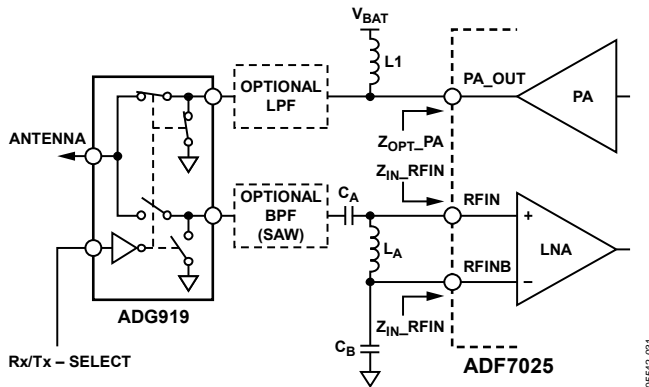

Figure 31. ADF7025 with External Rx/Tx Switch

$Z_{OPT\_PA}$  depends on various factors such as the required output power, the frequency range, the supply voltage range, and the temperature range. Selecting an appropriate  $Z_{OPT\_PA}$  helps to minimize the Tx current consumption in the application. This data sheet contains a number of  $Z_{OPT\_PA}$  values for representative conditions. Under certain conditions, however, it is recommended to obtain a suitable  $Z_{OPT\_PA}$  value by means of a load-pull measurement.

Due to the differential LNA input, the LNA matching network must be designed to provide both a single-ended to differential conversion and a complex conjugate impedance match. The network with the lowest component count that can satisfy these requirements is the configuration shown in Figure 31, which consists of two capacitors and one inductor.

A first-order implementation of the matching network can be obtained by understanding the arrangement as two L-type matching networks in a back-to-back configuration. Due to the asymmetry of the network with respect to ground, a compromise between the input reflection coefficient and the maximum differential signal swing at the LNA input must be established. The use of appropriate CAD software is strongly recommended for this optimization.

Depending on the antenna configuration, the user might need a harmonic filter at the PA output to satisfy the spurious emission requirement of the applicable government regulations. The harmonic filter can be implemented in various ways, such as a discrete LC filter or T-stage filter. Dielectric low-pass filter components such as the LFL18924MTC1A052 (for operation in the 915 MHz band), or LFL18869MTC2A160 (for operation in the 868 MHz band), both by Murata Mfg. Co., Ltd., represent an attractive alternative to discrete designs. The immunity of the ADF7025 to strong out-of-band interference can be improved by adding a band-pass filter in the Rx path.

#### Internal Rx/Tx Switch

Figure 32 shows the ADF7025 in a configuration where the internal Rx/Tx switch is used with a combined LNA/PA matching network. This is the configuration used in the EVAL-ADF7025DBZ1. For most applications, the slight performance degradation of 1 dB to 2 dB caused by the internal Rx/Tx switch is acceptable, allowing the user to take advantage of the cost-saving potential of this solution. The design of the combined matching network must compensate for the reactance presented by the networks in the Tx and the Rx paths, taking the state of the Rx/Tx switch into consideration.

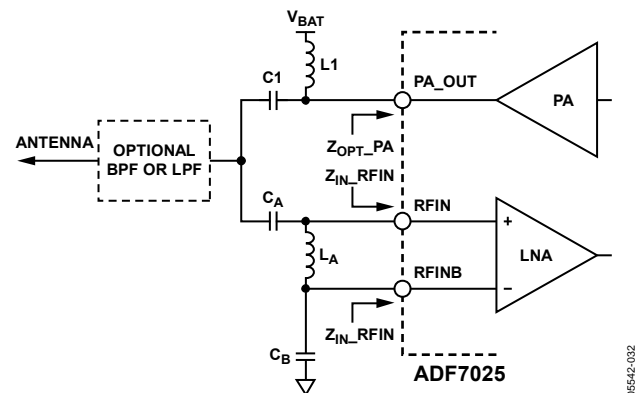

Figure 32. ADF7025 with Internal Rx/Tx Switch

The procedure typically requires several iterations until an acceptable compromise is reached. The successful implementation of a combined LNA/PA matching network for the ADF7025 is critically dependent on the availability of an accurate electrical model for the PC board. In this context, the use of a suitable CAD package is strongly recommended. To avoid this effort, however, a small form-factor reference design for the ADF7025 is provided, including matching and harmonic filter components. The design is on a 2-layer PCB to minimize cost. Gerber files are available on product page at [www.analog.com/ADF7025](http://www.analog.com/ADF7025).

**TRANSMIT PROTOCOL AND CODING CONSIDERATIONS**

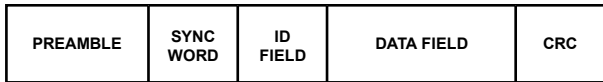

Figure 33. Typical Format of a Transmit Protocol

A dc-free preamble pattern is recommended for FSK demodulation. The recommended preamble pattern is a dc-free pattern such as a 10101010... pattern. Preamble patterns with longer run-length constraints such as 11001100... can also be used. However, this results in a longer synchronization time of the received bit stream in the receiver.

Manchester coding can be used for the entire transmit protocol. However, the remaining fields that follow the preamble header do not have to use dc-free coding. For these fields, the ADF7025 can accommodate coding schemes with a run-length of up to six bits without any performance degradation.

If longer run-length coding must be supported, the ADF7025 has several other features that can be activated. These involve a range of programmable options that allow the envelope detector output to be frozen after preamble acquisition.

**DEVICE PROGRAMMING AFTER INITIAL POWER-UP**

Table 7 lists the minimum number of writes needed to set up the ADF7025 in either Tx or Rx mode after CE is brought high. Additional registers can also be written to tailor the part to a particular application, such as setting up sync byte detection. When going from Tx to Rx or vice versa, the user needs to write only to the N register to alter the LO by 200 kHz and to toggle the Tx/Rx bit.

**Table 7. Minimum Register Writes Required for Tx/Rx Setup**

Mode	Registers					
Tx	0	1	2			
Rx (FSK)	0	1	2	4	6	9 <sup>1</sup>
Tx to Rx and Rx to Tx	0					

<sup>1</sup> Register 9 should be programmed in receive mode in order to set the recommended AGC threshold settings (low = 15, high = 79).

Figure 36 and Figure 37 show the recommended programming sequence and associated timing for power-up from standby mode.

**INTERFACING TO MICROCONTROLLER/DSP**

Low level device drivers are available for interfacing to the ADF7025, the Analog Devices, Inc., ADuC841 microcontroller or the Blackfin® ADSP-BF533 DSP using the hardware connections shown in Figure 34 and Figure 35.

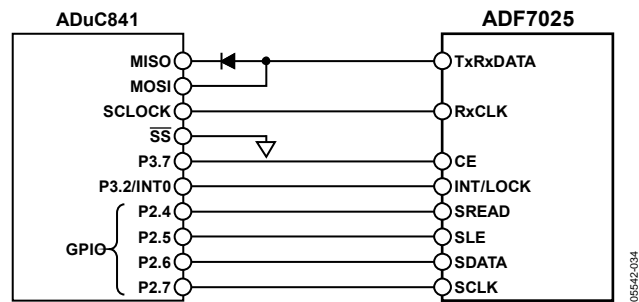

Figure 34. ADuC841 to ADF7025 Connection Diagram

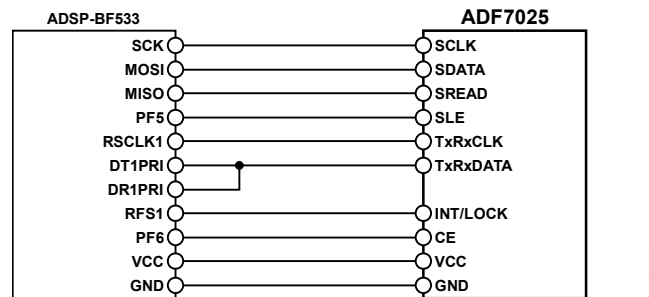

Figure 35. ADSP-BF533 to ADF7025 Connection Diagram

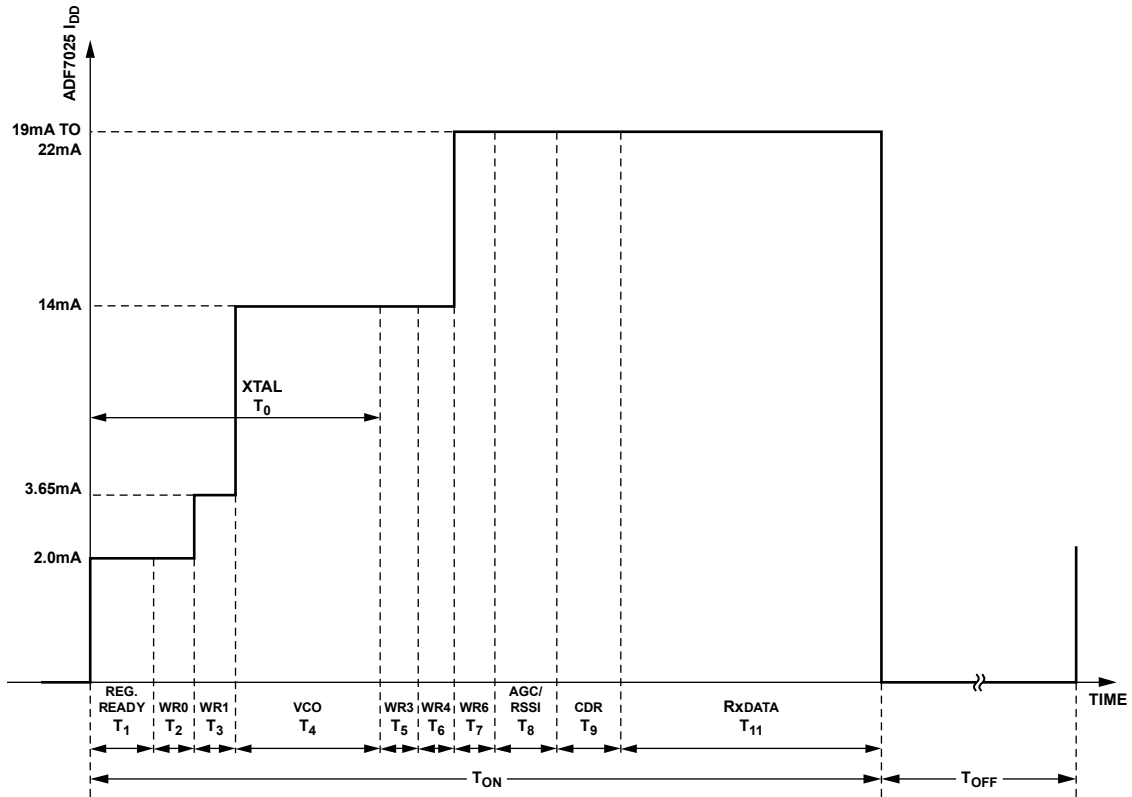

Figure 36. Rx Programming Sequence and Timing Diagram

Table 8. Power-Up Sequence Description

Parameter	Value	Description/Notes	Signal to Monitor
T <sub>0</sub>	2 ms	XTAL starts power-up after CE is brought high. This typically depends on the XTAL type and the load capacitance specified.	CLKOUT
T <sub>1</sub>	10 μs	Time for regulator to power up. The serial interface can be written to after this time.	MUXOUT
T <sub>2</sub> , T <sub>3</sub> , T <sub>5</sub> , T <sub>6</sub> , T <sub>7</sub>	32 × 1/SPI_CLK	Time to write to a single register. Maximum SPI_CLK is 25 MHz.	
T <sub>4</sub>	1 ms	The VCO can power-up in parallel with the XTAL. This depends on the CVCO capacitance value used. A value of 22 nF is recommended as a trade-off between phase noise performance and power-up time.	CVCO pin
T <sub>8</sub>	150 μs	This depends on the number of gain changes the AGC loop needs to cycle through and AGC settings programmed. This is described in more detail in the AGC Information section.	Analog RSSI on TEST_A pin
T <sub>9</sub>	5 × BIT_PERIOD	This is the time for the clock and data recovery circuit to settle. This typically requires 5-bit transitions to acquire sync and is usually covered by the preamble.	
T <sub>11</sub>	Packet length	Number of bits in payload by the bit period.	

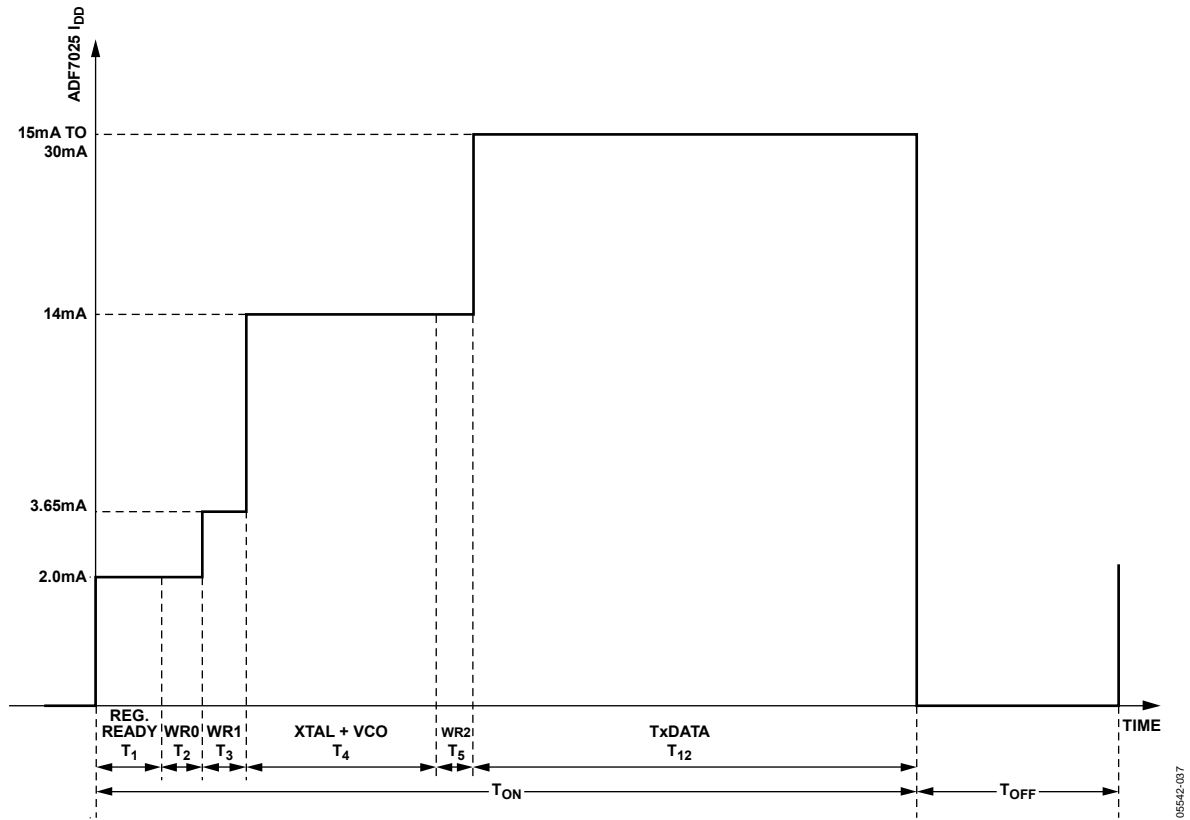

Figure 37. Tx Programming Sequence and Timing Diagram

055421037

## SERIAL INTERFACE

The serial interface allows the user to program the eleven 32-bit registers using a 3-wire interface (SCLK, SDATA, and SLE). It consists of a level shifter, a 32-bit shift register, and 11 latches. Signals should be CMOS-compatible. The serial interface is powered by the regulator, and, therefore, is inactive when CE is low.

Data is clocked into the register, MSB first, on the rising edge of each clock (SCLK). Data is transferred to one of 11 latches on the rising edge of SLE. The destination latch is determined by the value of the four control bits (C4 to C1). These are the bottom four LSBs, DB3 to DB0, as shown in the timing diagram in Figure 2. Data can also be read back on the SREAD pin.

### READBACK FORMAT

The readback operation is initiated by writing a valid control word to the readback register and setting the readback-enable bit (R7\_DB8 = 1). The readback can begin after the control word has been latched with the SLE signal. SLE must be kept high while the data is being read out. Each active edge at the SCLK pin clocks the readback word out successively at the SREAD pin, as shown in Figure 38, starting with the MSB first. The data appearing at the first clock cycle following the latch operation must be ignored.

#### RSSI Readback

The RSSI readback operation yields valid results in Rx mode. The format of the readback word is shown in Figure 38. It comprises the RSSI level information (Bit RV1 to Bit RV7), the current filter gain (FG1 and FG2), and the current LNA gain (LG1 and LG2) setting. The filter and LNA gain are coded in accordance with the definitions in Register 9—AGC Register. The input power can be calculated from the RSSI readback value, as outlined in the RSSI/AGC section.

#### Battery Voltage ADCIN/Temperature Sensor Readback

The battery voltage is measured at Pin VDD4. The readback information is contained in Bit RV1 to Bit RV7. This also applies for the readback of the voltage at the ADCIN pin and the temperature sensor. From the readback information, the battery or ADCIN voltage can be determined using

$$V_{BATTERY} = (BATTERY\_VOLTAGE\_READBACK)/21.1$$

$$V_{ADCIN} = (ADCIN\_VOLTAGE\_READBACK)/42.1$$

#### Silicon Revision Readback

The silicon revision readback word is valid without setting any other registers, especially directly after power-up. The silicon revision word is coded with four quartets in BCD format. The product code (PC) is coded with two quartets extending from Bit RV9 to Bit RV16. The revision code (RV) is coded with one quartet extending from Bit RV1 to Bit RV8. The product code should read back as PC = 0x25. The current revision code should read as RC = 0x08.

#### Filter Calibration Readback

The filter calibration readback word is contained in Bit RV1 to Bit RV8 and is for diagnostic purposes only. Using the automatic filter calibration function, accessible through Register 6, is recommended. Before filter calibration is initiated, Decimal 32 should be read back.

READBACK MODE	READBACK VALUE															
	DB15	DB14	DB13	DB12	DB11	DB10	DB9	DB8	DB7	DB6	DB5	DB4	DB3	DB2	DB1	DB0
RSSI READBACK	X	X	X	X	X	LG2	LG1	FG2	FG1	RV7	RV6	RV5	RV4	RV3	RV2	RV1
BATTERY VOLTAGE/ADCIN/TEMP. SENSOR READBACK	X	X	X	X	X	X	X	X	X	RV7	RV6	RV5	RV4	RV3	RV2	RV1
SILICON REVISION	RV16	RV15	RV14	RV13	RV12	RV11	RV10	RV9	RV8	RV7	RV6	RV5	RV4	RV3	RV2	RV1
FILTER CAL READBACK	0	0	0	0	0	0	0	0	RV8	RV7	RV6	RV5	RV4	RV3	RV2	RV1

Figure 38. Readback Value Table

05E42-008

# REGISTERS

## REGISTER 0—N REGISTER

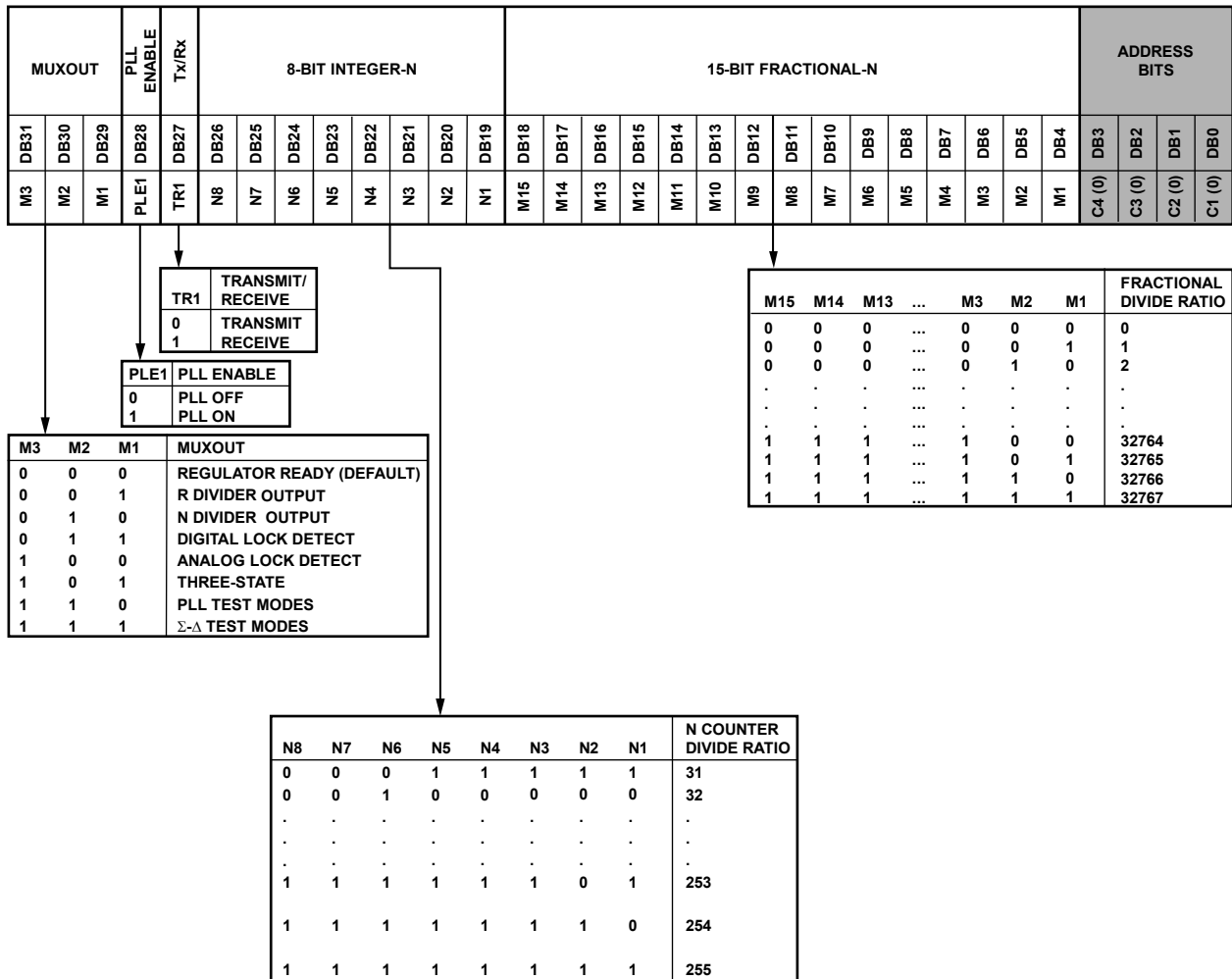

Figure 39. Register 0—N Register

### Register 0—N Register Comments

- The Tx/Rx bit (R0\_DB27) configures the part in Tx or Rx mode and also controls the state of the internal Tx/Rx switch.

$$F_{OUT} = \frac{XTAL}{R} \times \left( Integer\ N + \frac{Fractional\ N}{2^{15}} \right)$$

- If operating in 433 MHz band with the VCO band bit set, the desired frequency, F<sub>OUT</sub>, should be programmed to be twice the desired operating frequency, due to removal of the divide-by-2 stage in feedback path.

05542-039

REGISTER 1—OSCILLATOR/FILTER REGISTER

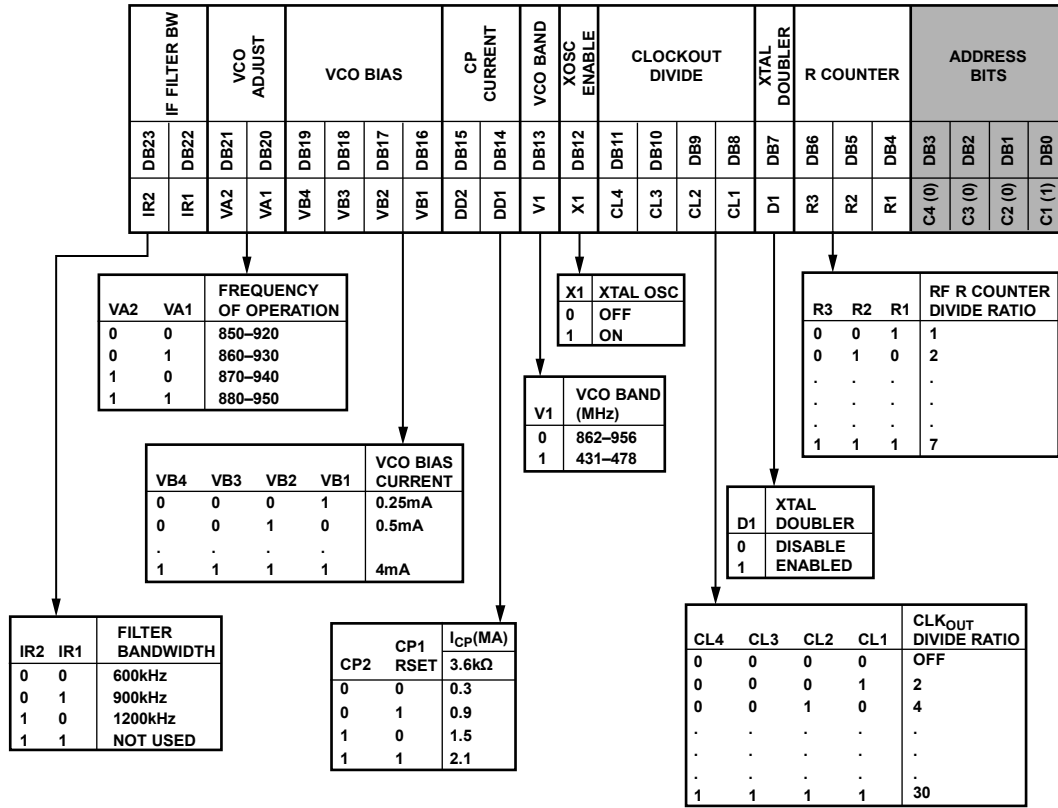

Figure 40. Register 1—Oscillator/Filter Register

05E42-040

Register 1—Oscillator/Filter Register Comments

- The VCO Adjust Bits R1\_DB[20:21] should be set to 0 for operation in the 862 MHz to 870 MHz band and set to 3 for operation in the 902 MHz to 928 MHz band.
- VCO bias setting should be 0xA for operation in the 862 MHz to 870 MHz band and 0xC for operation in the 902 MHz to 928 MHz band. All VCO gain numbers are specified for these settings.

REGISTER 2—TRANSMIT MODULATION REGISTER

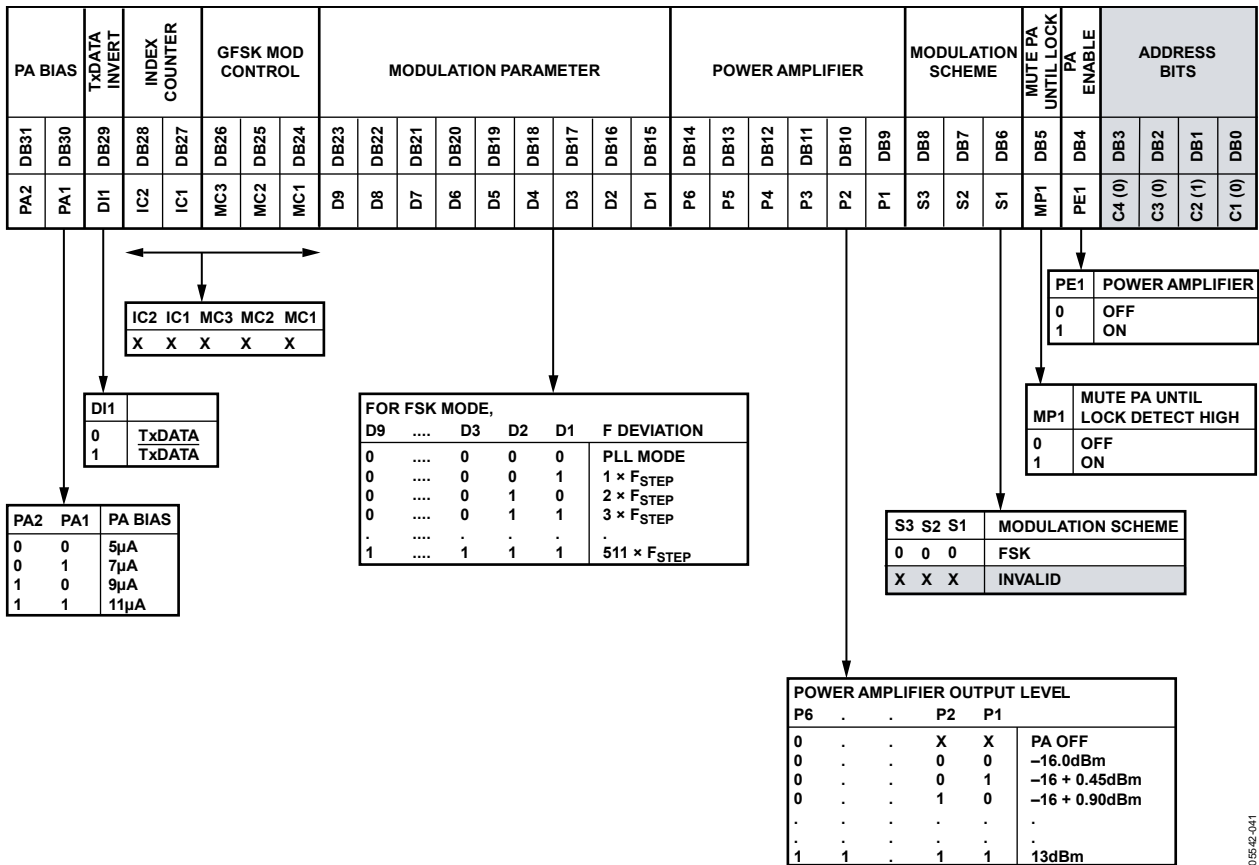

Figure 41. Register 2—Transmit Modulation Register

Register 2—Transmit Modulation Register Comments

- $F_{STEP} = PFD/12^{14}$ .
- When operating in the 431 MHz to 464 MHz band,  $F_{STEP} = PFD/12^{15}$ .
- PA bias default = 9 µA.

08542-041

**REGISTER 3—RECEIVER CLOCK REGISTER**

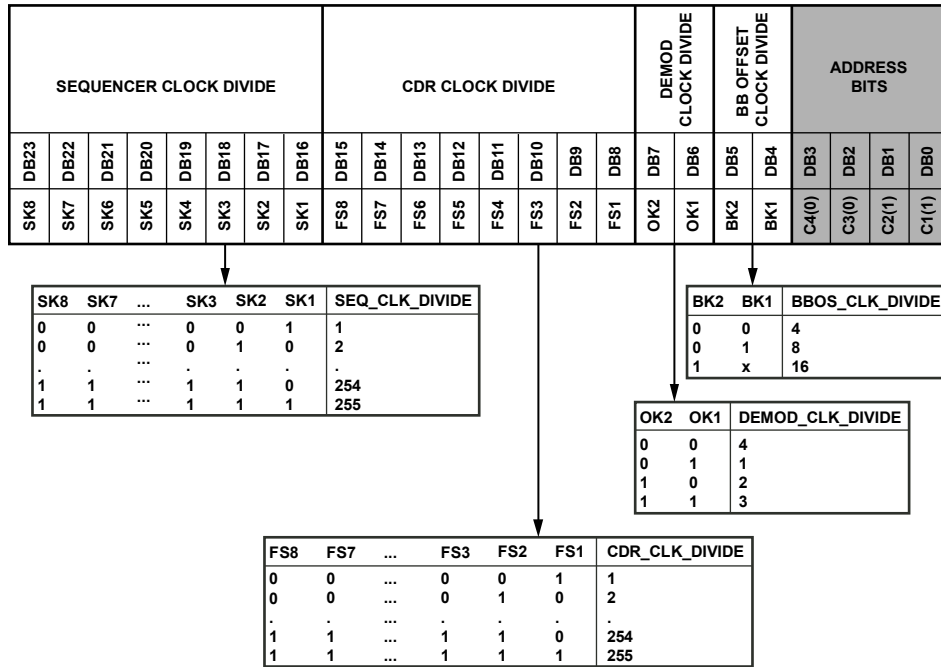

Figure 42. Register 3—Receiver Clock Register

09542-942

**Register 3—Receiver Clock Register Comments**

- Baseband offset clock frequency (BBOS\_CLK) must be greater than 1 MHz and less than 2 MHz, where:

$$BBOS\_CLK = \frac{XTAL}{BBOS\_CLK\_DIVIDE}$$

- The demodulator clock (DEMOM\_CLK) must be < 12 MHz, where:

$$DEMOM\_CLK = \frac{XTAL}{DEMOM\_CLK\_DIVIDE}$$

- Data/clock recovery frequency (CDR\_CLK) should be within 2% of (32 × data rate), where:

$$CDR\_CLK = \frac{DEMOM\_CLK}{CDR\_CLK\_DIVIDE}$$

Note that this can affect the choice of XTAL, depending on the desired data rate.

- The sequencer clock (SEQ\_CLK) supplies the clock to the digital receive block. It should be close to 100 kHz.

$$SEQ\_CLK = \frac{XTAL}{SEQ\_CLK\_DIVIDE}$$

REGISTER 4—DEMODULATOR SETUP REGISTER

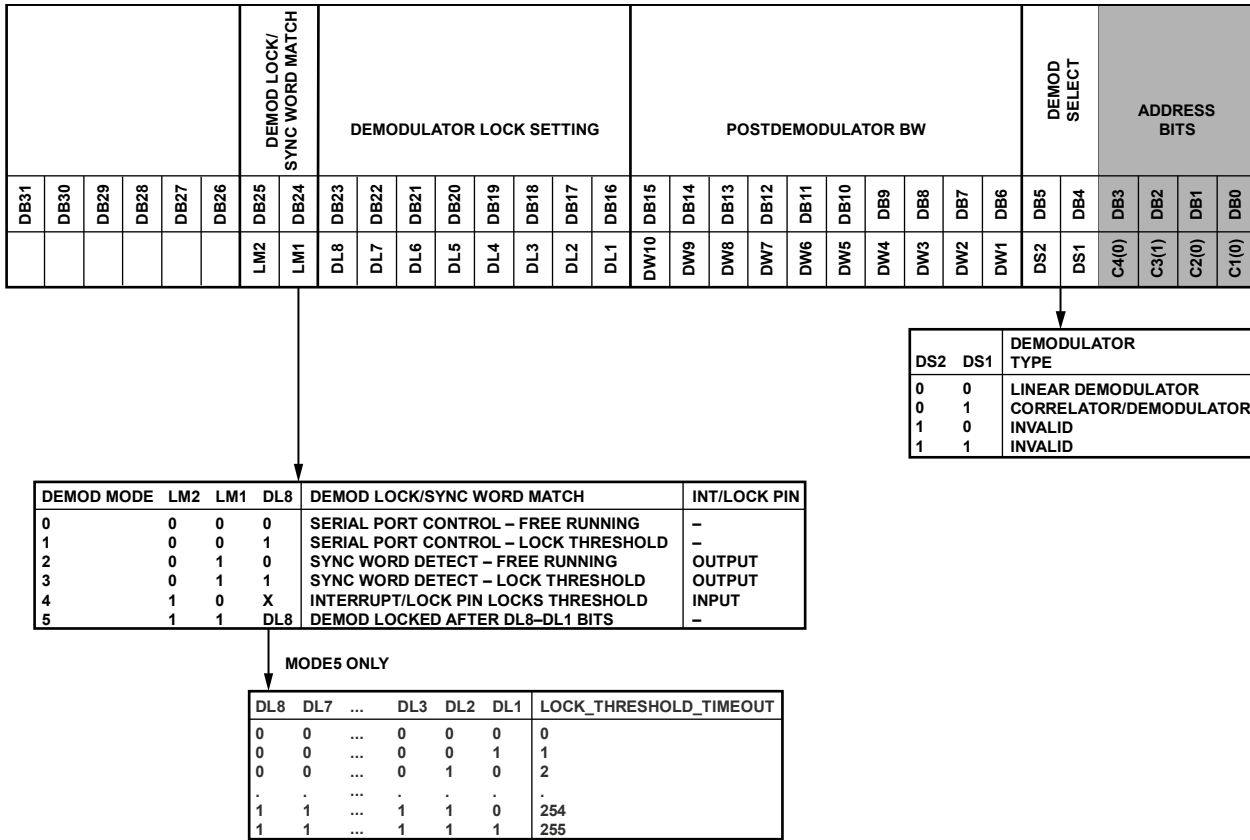

Figure 43. Register 4—Demodulator Setup Register

**Register 4—Demodulator Setup Register Comments**

- Demodulator Mode 1, Demodulator Mode 3, Demodulator Mode 4, and Demodulator Mode 5 are modes that can be activated to allow the ADF7025 to demodulate data-encoding schemes that have run-length constraints greater than 7.
- $POST\_DEMOD\_BW = \frac{2^{11} \times \pi \times F_{CUTOFF}}{DEMOD\_CLK}$ , where the cutoff frequency ( $F_{CUTOFF}$ ) of the postdemodulator filter should typically be 0.75 times the data rate.
- For Mode 5, the *Timeout Delay to Lock Threshold* =  $(LOCK\_THRESHOLD\_SETTING)/SEQ\_CLK$ , where  $SEQ\_CLK$  is defined in the Register 3—Receiver Clock Register section.

05542-043

**REGISTER 5—SYNC BYTE REGISTER**

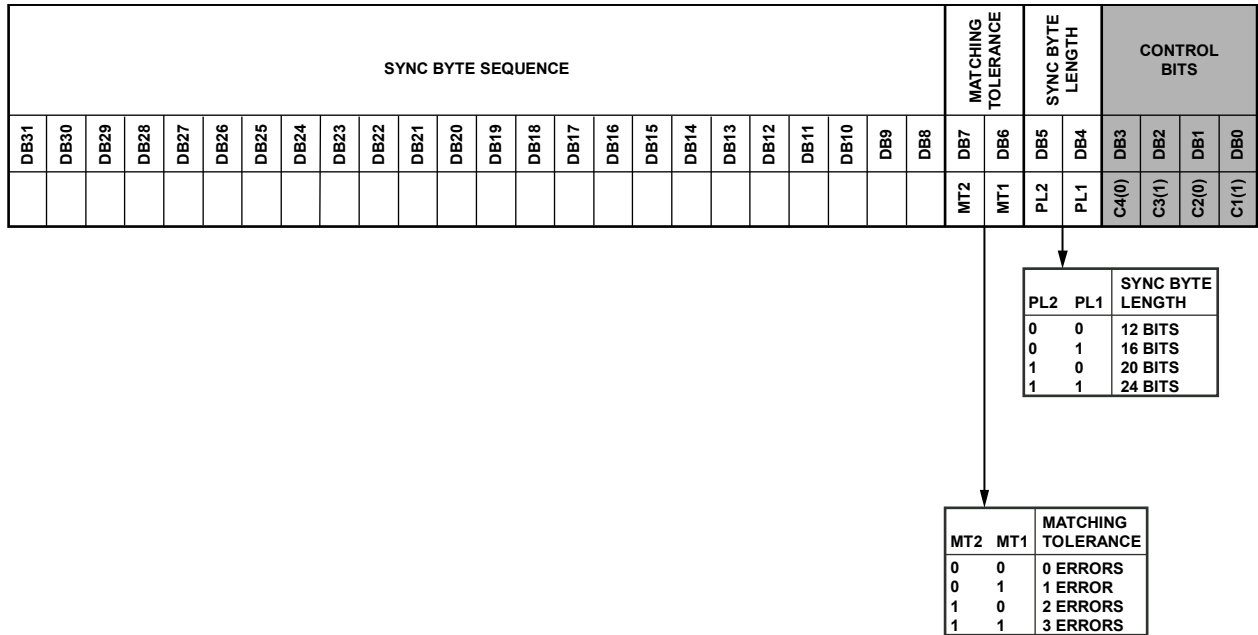

Figure 44. Register 5—Sync Byte Register

08542-044

**Register 5—Sync Byte Register Comments**

- Sync byte detect is enabled by programming Bits R4\_DB[25:23] to 010 or 011.
- This register allows a 24-bit sync byte sequence to be stored internally. If the sync byte detect mode is selected, then the INT/LOCK pin goes high when the sync byte has been detected in Rx mode. Once the sync word detect signal has gone high, it goes low again after nine data bits.
- The transmitter must transmit the MSB of the sync byte first and the LSB last to ensure proper alignment in the receiver sync byte detection hardware.
- Choose a sync byte pattern that has good autocorrelation properties.

REGISTER 6—CORRELATOR/DEMODULATOR REGISTER

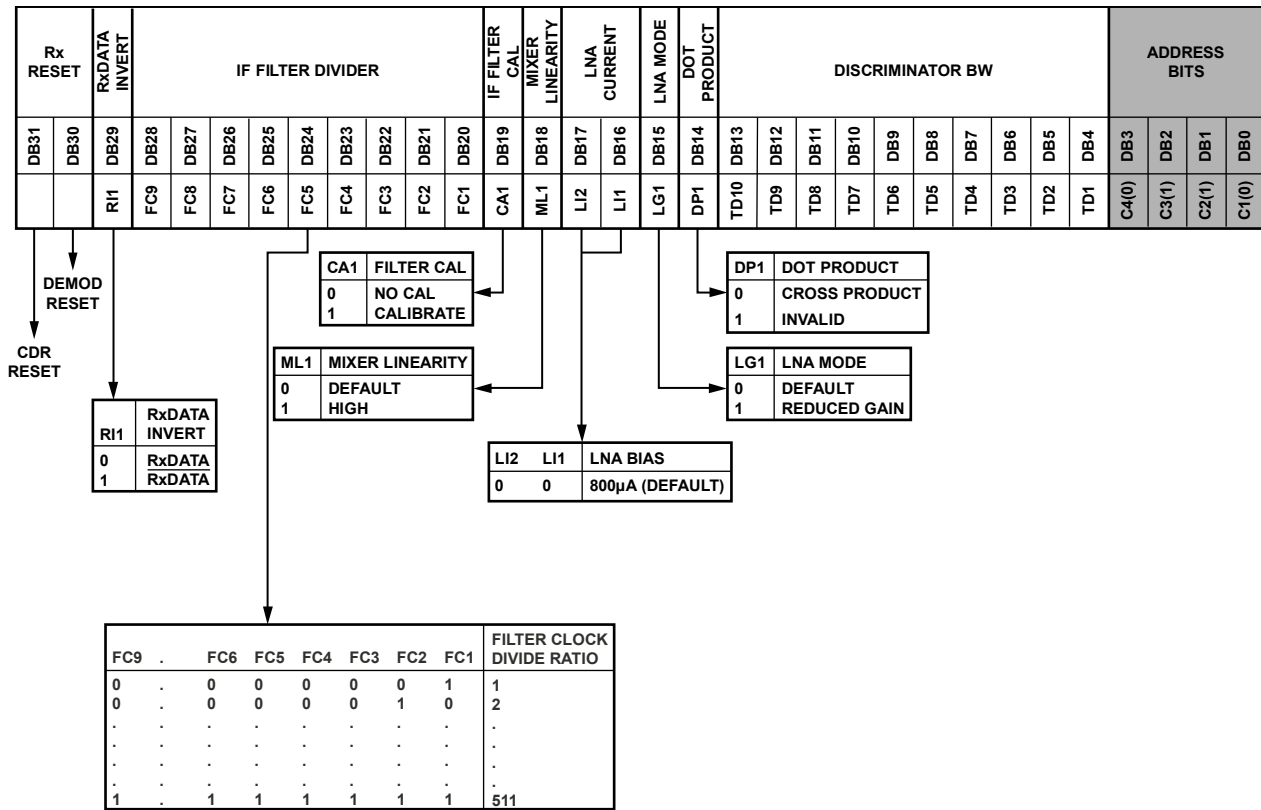

Figure 45. Register 6—Correlator/Demodulator Register

Register 6—Correlator/Demodulator Register Comments

- See the FSK Correlator/Demodulator section for an example of how to determine register settings.
- Nonadherence to correlator programming guidelines results in poor sensitivity.
- The filter clock is used to calibrate the LP filter. The filter clock divide ratio should be adjusted so that the frequency is 50 kHz. The formula is XTAL/FILTER\_CLOCK\_DIVIDE.
- The filter should be calibrated only when the crystal oscillator is settled. The filter calibration is initiated every time Bit R6\_DB19 is set high.
- $DISCRIMINATOR\_BW = DEMOD\_CLK / (4 \times DEVIATION\_FREQUENCY)$ . See the FSK Correlator/Demodulator section. *Maximum value* = 600.
- When LNA Mode = 1 (reduced gain mode), the Rx is prevented from selecting the highest LNA gain setting. This can be used when linearity is a concern. See the Readback Format section for details of the different Rx modes.

05542-045

**REGISTER 7—READBACK SETUP REGISTER**

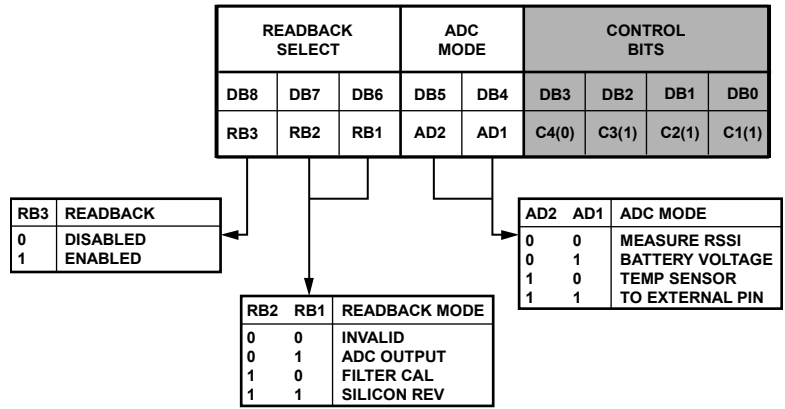

Figure 46. Register 7—Readback Setup Register

05E42-046

**Register 7—Readback Setup Register Comments**

- Readback of the measured RSSI value is valid only in Rx mode. Readback of the battery voltage, the temperature sensor, and the voltage at the external pin is not available in Rx mode if AGC is enabled.
- Readback of the ADC value is valid in Tx mode only if the log amp/RSSI has not been disabled through the Power-Down Bit R8\_DB10. The log amp/RSSI section is active by default upon enabling Tx mode.
- See the Readback Format section for more information.

REGISTER 8—POWER-DOWN TEST REGISTER

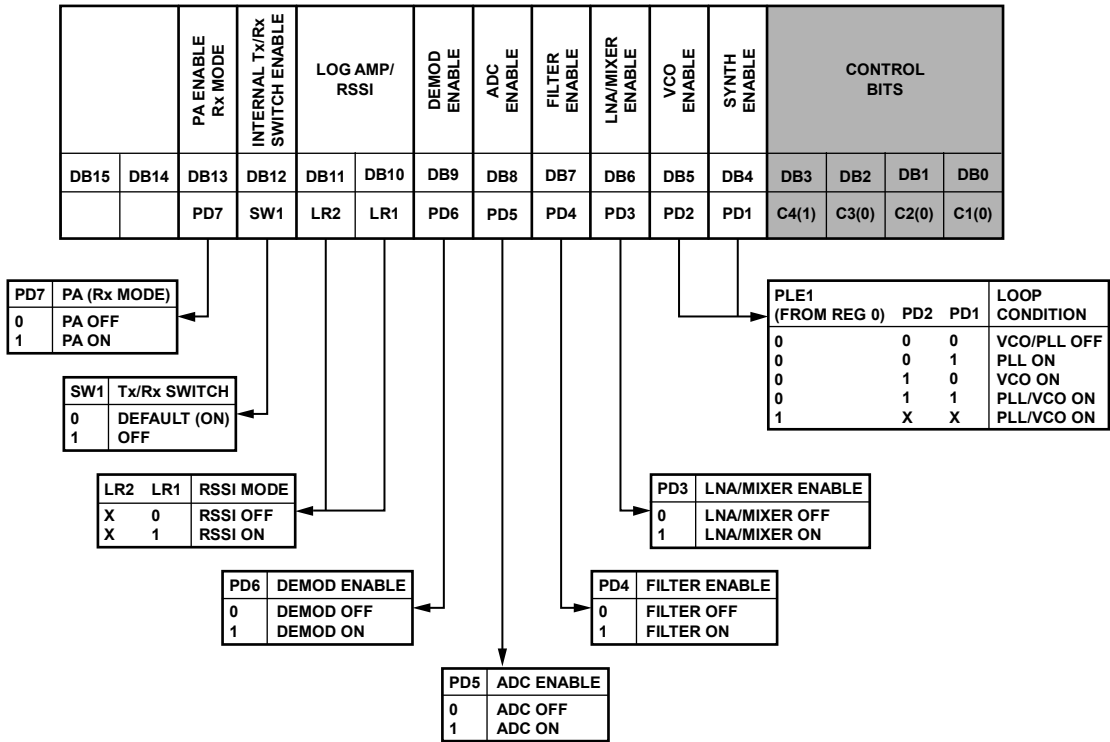

Figure 47. Register 8—Power-Down Test Register

05542-047

**Register 8—Power-Down Test Register Comments**

- For a combined LNA/PA matching network, Bit R8\_DB12 should always be set to 0. This is the power-up default condition.
- It is not necessary to write to this register under normal operating conditions.

REGISTER 9—AGC REGISTER

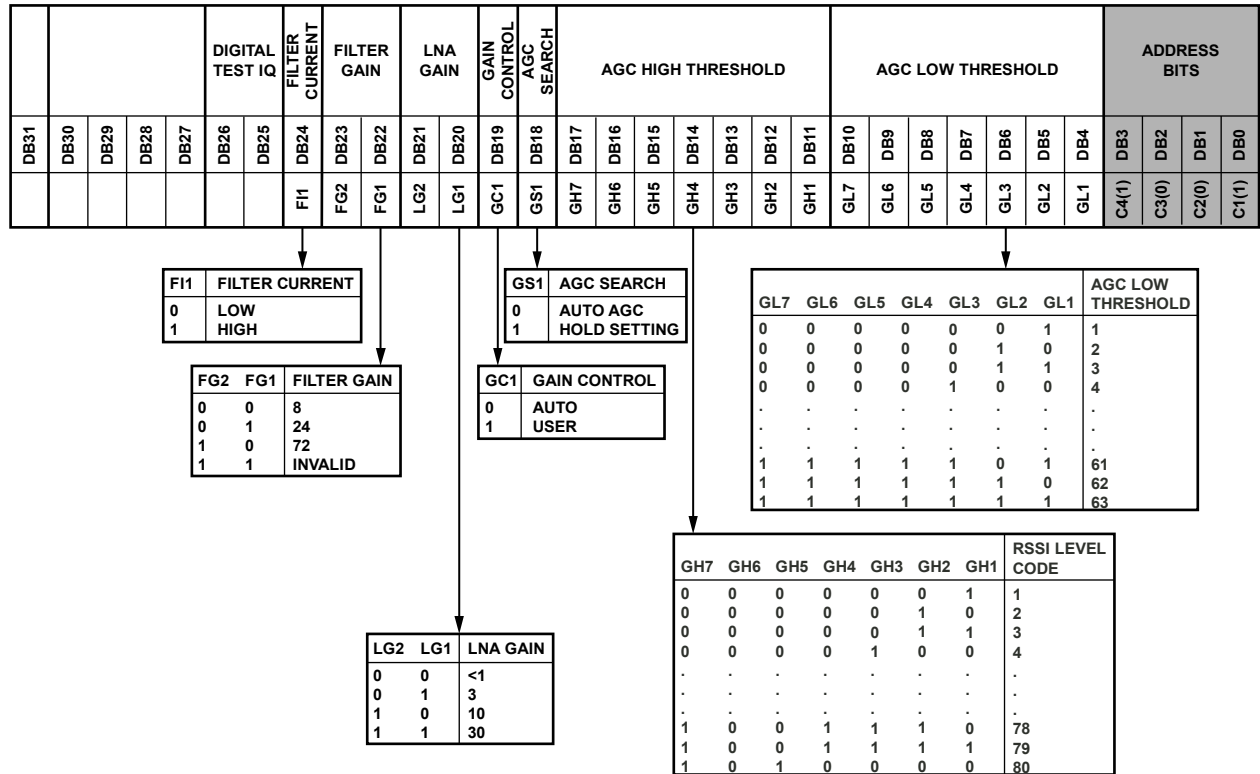

Figure 48. Register 9—AGC Register

08542-948

**Register 9—AGC Register Comments**

- The recommended AGC threshold settings are AGC\_LOW\_THRESHOLD = 15, AGC\_HIGH\_THRESHOLD = 79. The default settings (that is, if this register is not programmed) are AGC\_LOW\_THRESHOLD = 30, default AGC\_HIGH\_THRESHOLD = 70. See the RSSI/AGC section for details.
- AGC high and low settings must be more than 30 apart to ensure correct operation.
- LNA gain of 30 is available only if LNA mode, R6\_DB15, is set to 0.

**REGISTER 10—AGC 2 REGISTER**

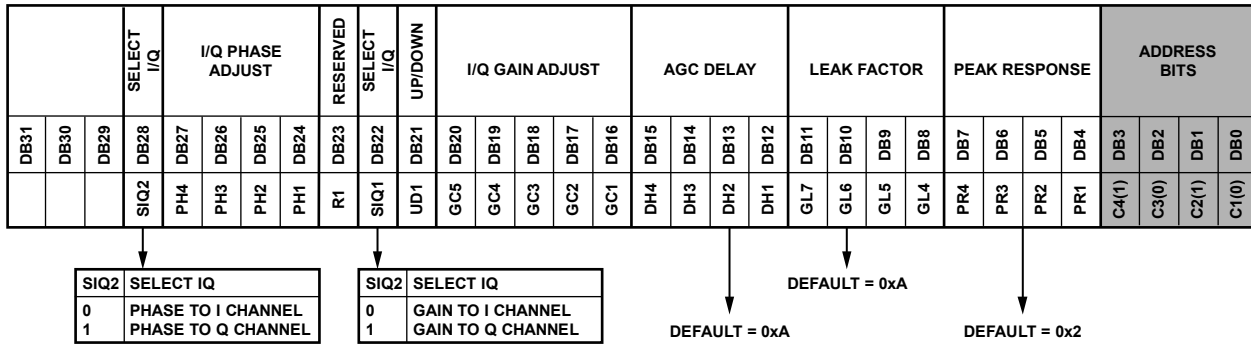

Figure 49. Register 10—AGC 2 Register

**Register 10—AGC 2 Register Comments**

- Register 10 is not used under normal operating conditions.
- If adjusting AGC Delay or Leak Factor, clear Bit DB31 to Bit DB16.

05E42-049

REGISTER 12—TEST REGISTER

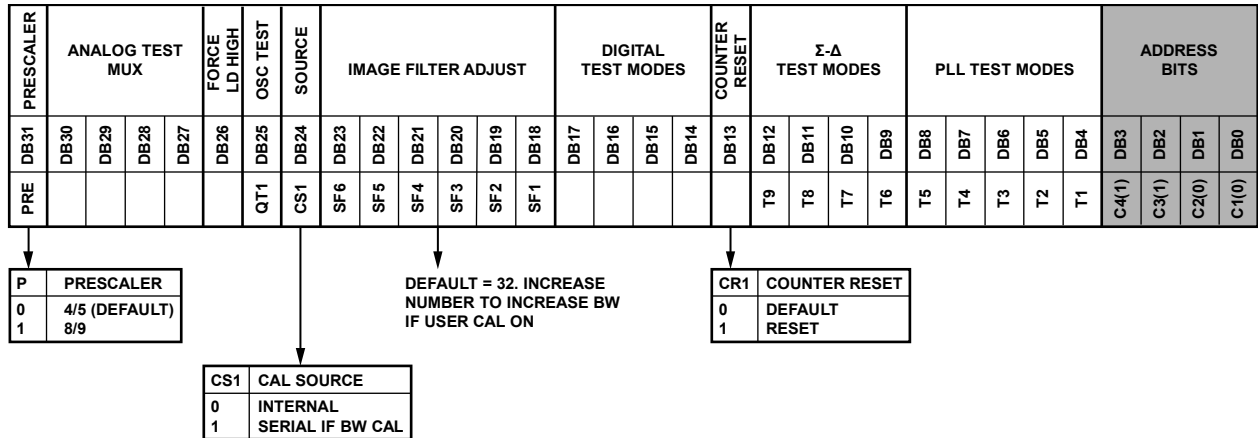

Figure 50. Register 12—Test Register

05E42-050

**Using the Test DAC on the ADF7025 to Implement Analog FM DEMOD and Measuring SNR**

The test DAC allows the output of the postdemodulator filter for both the linear and correlator/demodulators to be viewed externally. It takes the 16-bit filter output and converts it to a high frequency, single-bit output using a second-order error feedback Σ-Δ converter. The output can be viewed on the XCLK<sub>OUT</sub> pin. This signal, when IF-filtered appropriately, can then be used to

- Monitor the signals at the FSK postdemodulator filter output. This allows the demodulator output SNR to be measured. Eye diagrams can also be constructed of the received bit stream to measure the received signal quality.
- Provide analog FM demodulation.

While the correlators and filters are clocked by DEMOD\_CLK, CDR\_CLK clocks the test DAC. Note that, although the test DAC functions in a regular user mode, the best performance is achieved when the CDR\_CLK is increased up to or above the frequency of DEMOD\_CLK. The CDR block does not function when this condition exists.

Programming the test register, Register 12, enables the test DAC. Both the linear and correlator/demodulator outputs can be multiplexed into the DAC.

Register 13 allows a fixed offset term to be removed from the signal in the case where there is an error in the received signal frequency. If there is a frequency error in the signal, the user should program half this value into the offset removal field. It also has a signal gain term to allow usage of the maximum dynamic range of the DAC.

**Setting Up the Test DAC**

- Digital test modes = 7: enables the test DAC, with no offset removal (0x0001C00C).
- Digital test modes = 10: enables the test DAC, with offset removal.

The output of the active demodulator drives the DAC; that is, if the FSK correlator/demodulator is selected, the correlator filter output drives the DAC.

**REGISTER 13—OFFSET REMOVAL AND SIGNAL GAIN REGISTER**

TEST DAC GAIN						TEST DAC OFFSET REMOVAL						PULSE EXTENSION				KI				KP				CONTROL BITS											
DB31	DB30	DB29	DB28	DB27	DB26	DB25	DB24	DB23	DB22	DB21	DB20	DB19	DB18	DB17	DB16	DB15	DB14	DB13	DB12	DB11	DB10	DB9	DB8	DB7	DB6	DB5	DB4	DB3	DB2	DB1	DB0				
																PE4	PE3	PE2	PE1													C4(1)	C3(1)	C2(0)	C1(1)

PE4	PE3	PE2	PE1	PULSE EXTENSION
0	0	0	0	NORMAL PULSE WIDTH
0	0	0	1	2× PULSE WIDTH
0	0	1	0	3× PULSE WIDTH
.	.	.	.	.
.	.	.	.	.
1	1	1	1	16× PULSE WIDTH

Figure 51. Register 13—Offset Removal and Signal Gain Register

05542-051

**Register 13—Offset Removal and Signal Gain Register Comments**

Because the linear demodulator output is proportional to frequency, it usually consists of an offset combined with a relatively low signal. The offset can be removed, up to a maximum of 1.0, and gained to use the full dynamic range of the DAC, as follows:

$$DAC\_INPUT = (2^{TEST\_DAC\_GAIN}) \times (Signal - TEST\_DAC\_OFFSET\_REMOVAL/4096).$$

# OUTLINE DIMENSIONS

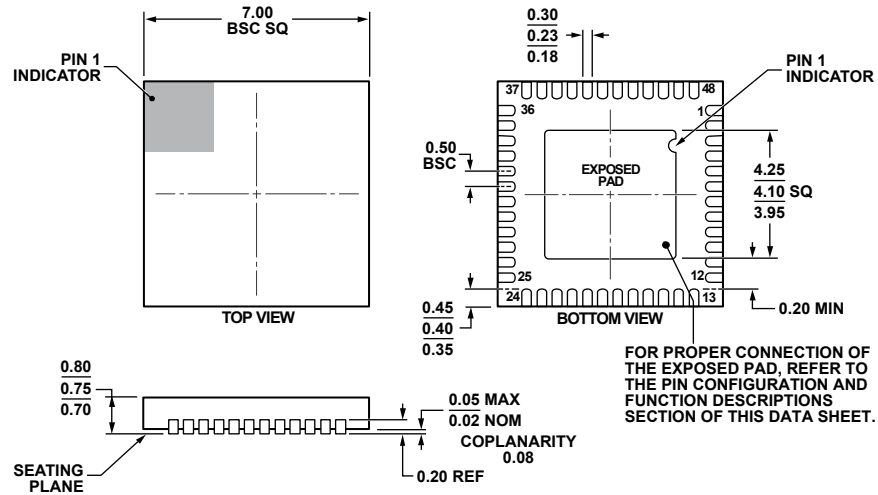

COMPLIANT TO JEDEC STANDARDS MO-220-WKKD.

Figure 52. 48-Lead Lead Frame Chip Scale Package [LFCSP\_WQ]  
7 mm x 7 mm Body, Very Thin Quad  
(CP-48-5)  
Dimensions shown in millimeters

08-16-2010-B

## ORDERING GUIDE

Model <sup>1</sup>	Temperature Range	Package Description	Package Option <sup>2</sup>
ADF7025BCPZ	-40°C to +85°C	48-Lead Lead Frame Chip Scale Package [LFCSP_WQ]	CP-48-5
ADF7025BCPZ-RL	-40°C to +85°C	48-Lead Lead Frame Chip Scale Package [LFCSP_WQ]	CP-48-5
ADF7025BCPZ-RL7	-40°C to +85°C	48-Lead Lead Frame Chip Scale Package [LFCSP_WQ]	CP-48-5
EVAL-ADF70XXMBZ2		Evaluation Platform	
EVAL-ADF7025DBZ1		902 MHz to 928 MHz Daughter Board	

<sup>1</sup> Z = RoHS Compliant Part.

<sup>2</sup> CP-48-5 package formerly CP-48-3.

## Looking for pricing, stock, or lifecycle information?

Click below to explore more details on WIN SOURCE:

 [View ADF7025BCPZ on WIN SOURCE](#)

 [Analog Devices Inc. Information](#)

## Optimize Your Supply Chain with WIN SOURCE Solutions

-  Global Sourcing Solution
-  Obsolete Management
-  Cost Control Management
-  Shortage Management
-  Alternative Solution
-  Excess Inventory Management