



**THE DATASHEET OF
MP26101DR-LF-Z**



DESCRIPTION

The MP26101 is a monolithic switching charger for 1- or 2-cell Li-Ion battery packs. It has a built-in internal power MOSFET, and can output up to 2A of charge current with current mode control for fast loop response and easy compensation. The charge current can be programmed through an accurate sense resistor.

MP26101 regulates the charge current and charge voltage using two control loops to realize high-accuracy for both constant-current charge and constant-voltage charge.

Fault condition protection includes cycle-by-cycle current limiting and thermal shutdown. Other safety features include battery temperature monitoring, a charge status indicator, and a programmable timer to halt the charging cycle.

The MP26101 requires a minimal number of readily-available external components.

The MP26101 is available in 4mm×4mm 16-pin QFN package.

FEATURES

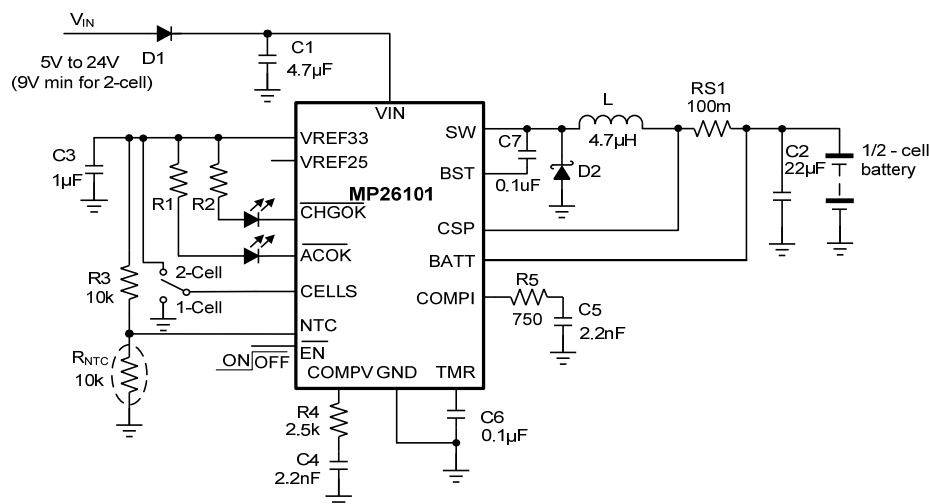
- Charges 1- or 2-cell Li-Ion battery packs
- 4.1V/Cell Charge Full Voltage
- 3.9V/Cell Auto-recharge Threshold
- Wide 5V to 24V Operating Input Range
- Up to 2A Programmable Charging Current
- $\pm 0.75\%$ V_{BATT} Accuracy
- 0.2Ω Internal Power MOSFET
- Up to 90% Efficiency
- Fixed 1.1MHz Frequency
- Preconditioning for Fully-Depleted Batteries
- Charging Status Indicator
- Input Supply and Battery Fault Indicator
- Thermal Shutdown
- Cycle-by-Cycle Over-Current Protection
- Battery Temperature Monitor and Protection

APPLICATIONS

- Distributed Power Systems
- Chargers for 1-Cell or 2-Cell Li-Ion Batteries
- Smartphones
- Portable DVD Player

For MPS green status, please visit MPS website under Quality Assurance. "MPS" and "The Future of Analog IC Technology" are Registered Trademarks of Monolithic Power Systems, Inc.

TYPICAL APPLICATION

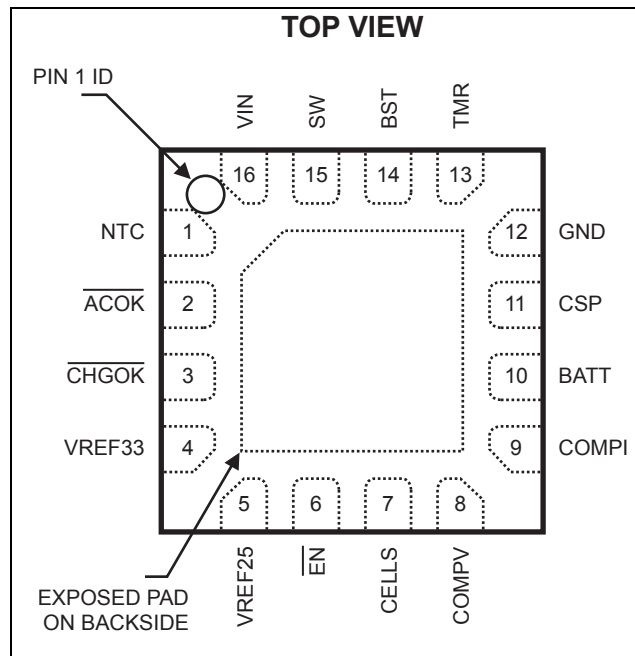


ORDERING INFORMATION

Part Number*	Package	Top Marking
MP26101NR	QFN16 (4×4mm)	M26101

* For Tape & Reel, add suffix-z (e.g. MP26101NR-Z);
 For RoHS Compliant packaging, add suffix-LF (e.g. MP26101NR-LF-Z)

PACKAGE REFERENCE



ABSOLUTE MAXIMUM RATINGS ⁽¹⁾

Supply Voltage V_{IN}	26V
V_{SW}	-0.3V to ($V_{IN} + 0.3V$)
V_{BST}	$V_{SW} + 6V$
V_{CSP}, V_{BATT}	-0.3V to +18V
All Other Pins	-0.3V to +6V
Continuous Power Dissipation ($T_A = 25^\circ C$) ⁽²⁾	2.7W
Junction Temperature	150°C
Lead Temperature	260°C
Storage Temperature	-65°C to +150°C

Recommended Operating Conditions ⁽³⁾

Supply Voltage V_{IN}	5V to 24V
Maximum Junction Temp. (T_J)	125°C

Thermal Resistance ⁽⁴⁾	θ_{JA}	θ_{JC}
QFN16 (4×4mm)	46	10 ... °C/W

Notes:

- 1) Exceeding these ratings may damage the device.
- 2) The maximum allowable power dissipation is a function of the maximum junction temperature $T_J(MAX)$, the junction-to-ambient thermal resistance θ_{JA} , and the ambient temperature T_A . The maximum allowable continuous power dissipation at any ambient temperature is calculated by $P_D(MAX) = (T_J(MAX) - T_A) / \theta_{JA}$. Exceeding the maximum allowable power dissipation will cause excessive die temperature, and the regulator will go into thermal shutdown. Internal thermal shutdown circuitry protects the device from permanent damage.
- 3) The device is not guaranteed to function outside of its operating conditions.
- 4) Measured on JESD51-7 4-layer board.

ELECTRICAL CHARACTERISTICS

$V_{IN} = 19V$, $T_A = 25^{\circ}C$, $CELLS=0V$, unless otherwise noted.

Parameters	Symbol	Condition	Min	Typ	Max	Units
Terminal Battery Voltage	V_{BATT}	CELLS=0V	4.069	4.1	4.131	V
		CELLS= VREF33	8.139	8.2	8.262	
CSP, BATT Current	I_{CSP}, I_{BATT}	Charging disabled		1		μA
Switch On Resistance	$R_{DS(ON)}$			0.2		Ω
Switch Leakage		$\overline{EN} = 4V, V_{SW} = 0V$		0	1	μA
Peak Current Limit		CC Mode ⁽⁵⁾		3.8		A
		Trickle Mode		1.75		A
CC current	I_{CC}	RS1= 100m Ω	1.8	2.0	2.2	A
Trickle charge current	$I_{TRICKLE}$			10%		I_{CC}
Trickle charge voltage threshold		CELLS=0V		2.87		V
		CELLS=3.3V		5.74		V
Trickle charge hysteresis				350		mV/cell
Termination current threshold	I_{BF}		5%	10%	15%	I_{CC}
Oscillator Frequency	f_{SW}	CELLS=0V, $V_{BATT} = 3.5V$		1.1		MHz
Fold-back Frequency		$V_{BATT} = 0V$		350		kHz
Maximum Duty Cycle			87			%
Maximum current Sense Voltage (CSP to BATT)	V_{SENSE}		170	200	230	mV
Minimum On Time ⁽⁵⁾	t_{ON}			100		ns
Under Voltage Lockout Threshold Rising			3	3.2	3.4	V
Under Voltage Lockout Threshold Hysteresis				200	1000	mV
Open-drain sink current (\overline{ACOK}), (\overline{CHGOK})		$V_{DRAIN} = 0.3V$	5			mA
Dead-battery indicator		In trickle mode $C_{TMR} = 0.1\mu F$		30		min
Termination delay		Time after I_{BF} reached $C_{TMR} = 0.1\mu F$		1		min
Recharge threshold at V_{BATT}	V_{RECHG}			3.9		V/cell
Recharge Hysteresis				100		mV/Cell
NTC Low Temp Rising Threshold		$R_{NTC} = NCP18XH103 (0^{\circ}C)$	70.5	73.5	76.5	%of VREF33
		Recovery Hysteresis		3		
NTC High Temp Falling Threshold		$R_{NTC} = NCP18XH103 (50^{\circ}C)$	27.5	29.5	31.5	%of VREF33
		Recovery Hysteresis		2		
VIN min head-room (reverse blocking)		$V_{IN} - V_{BATT}$		180		mV

ELECTRICAL CHARACTERISTICS (continued)
 $V_{IN} = 19V$, $T_A = 25^{\circ}C$, $CELLS=0V$, unless otherwise noted.

Parameters	Symbol	Condition	Min	Typ	Max	Units
Supply Current (Shutdown)		$\overline{EN}=4V$		0.16		mA
		$\overline{EN}=4V$, Consider VREF33 pin output current. $R_3=10k$, $R_{NTC}=10k$		0.32		mA
Supply Current (Quiescent)		$\overline{EN}=0V$, $CELLS=0V$			2.0	mA
\overline{EN} Input Low Voltage					0.4	V
\overline{EN} Input High Voltage			1.8			V
\overline{EN} Input Current		$\overline{EN}=4V$		4		μA
		$\overline{EN}=0V$		0.2		
Thermal Shutdown				150		$^{\circ}C$
VREF25 output voltage				2.5		V
VREF33 output voltage				3.3		V
VREF33 load regulation		$I_{LOAD} = 0$ to 10mA		30		mV

Notes:

5) Guaranteed by design.

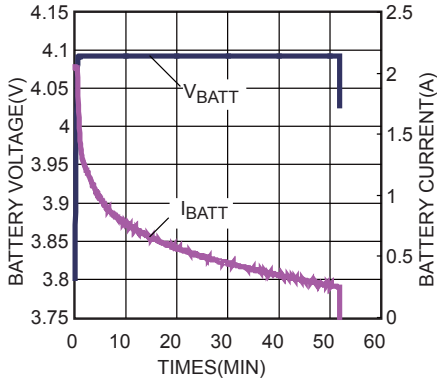
PIN FUNCTIONS

Pin #	Name	Description
1	NTC	Thermistor Input. Connect a resistor from this pin to the pin VREF33 and the Thermistor from this pin to ground.
2	$\overline{\text{ACOK}}$	Valid Input Supply Indicator. A logic LOW indicates the presence of a valid input supply.
3	$\overline{\text{CHGOK}}$	Charging Completion Indicator. A logic LOW indicates charging operation. The pin will become an open drain once charging has completed or suspended.
4	VREF33	Internal Linear Regulator 3.3V Reference Output. Bypass to GND with a 1 μ F ceramic capacitor.
5	VREF25	Internal Linear Regulator 2.5V Reference Output. PLEASE KEEP THIS PIN FLOATING
6	$\overline{\text{EN}}$	On/Off Control Input.
7	CELLS	Command Input. Sets the number of li-ion cells. Connect this pin to VREF33 for 2-cell operation or ground the pin for 1-cell operation. Do not leave this pin floating.
8	COMPV	V-LOOP Compensation. Connect this pin to GND with a capacitor and a resistor.
9	COMPI	I-LOOP Compensation. Connect this pin to GND with a capacitor and a resistor.
10	BATT	Positive Battery Terminal.
11	CSP	Battery Current Sense Positive Input. Connect a resistor RS1 between CSP and BATT. The full charge current is: $I_{\text{CHG}}(\text{A}) = \frac{200\text{mV}}{\text{RS1}(\text{m}\Omega)}$.
12	GND, Exposed Pad	Ground. This pin is the voltage reference for the regulated output voltage, and requires special layout considerations. This node should be placed outside of the switching diode (D2) to the input ground path to prevent switching current spikes from inducing voltage noise. Connect exposed pad to ground plane for optional thermal performance.
13	TMR	Set Time Constant. 0.1 μ A current charges and discharges the external cap.
14	BST	Bootstrap. Use a capacitor connected between BST and SW to drive the power switch's gate above the supply voltage..
15	SW	Switch Output.
16	VIN	Supply Voltage. The MP26101 operates from a 5V to 24V unregulated input to charge a 1- or 2-cell li-ion battery. Requires a capacitor to prevent large voltage spikes from appearing at the input.

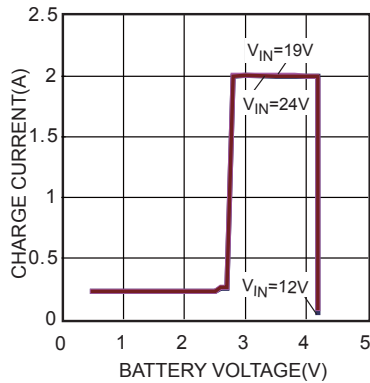
TYPICAL PERFORMANCE CHARACTERISTICS

$V_{IN}=19V$, $C1=4.7\mu F$, $C2=22\mu F$, $L=4.7\mu H$, $RS1=100m\Omega$, Real Battery Load, $T_A=25^\circ C$, unless otherwise noted.

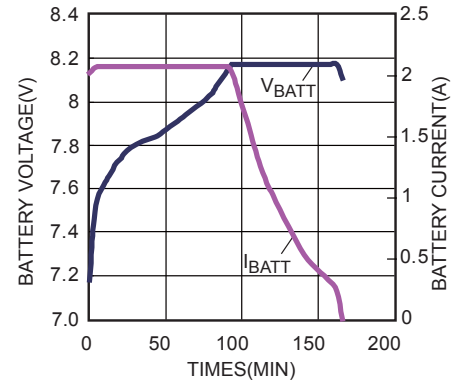
1-Cell Battery Charge Curve



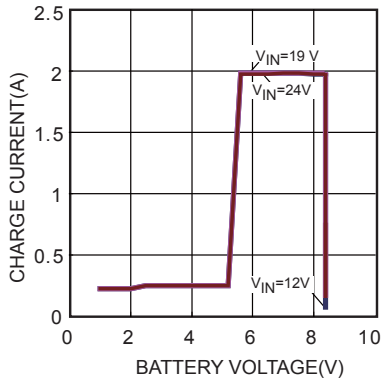
1-cell Charge Current vs. Battery Voltage



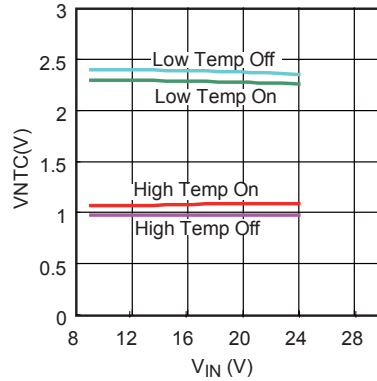
2-Cell Battery Charge Curve



2-cell Charge Current vs. Battery Voltage

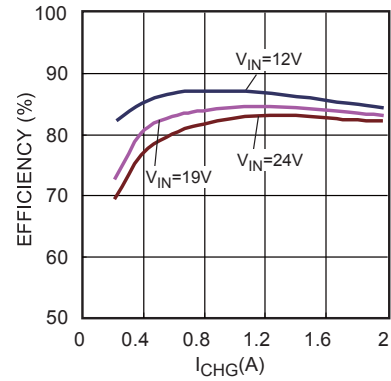


NTC Control Window



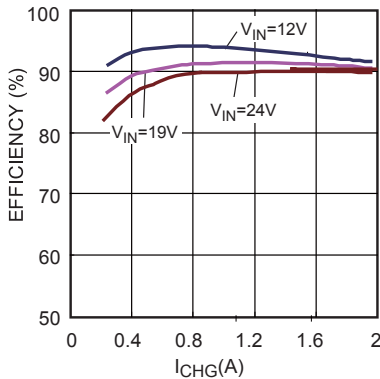
Efficiency vs. I_CHG

1-Cell, $V_{BATT}=4.1V$, CC Load

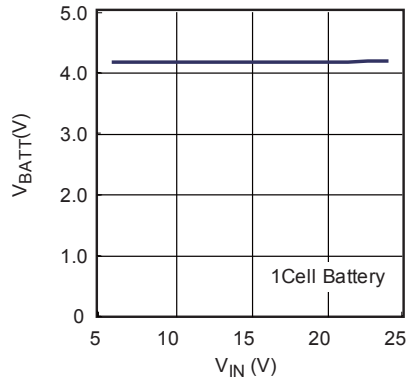


Efficiency vs. I_CHG

2-Cell, $V_{BATT}=8.2V$, CC Load

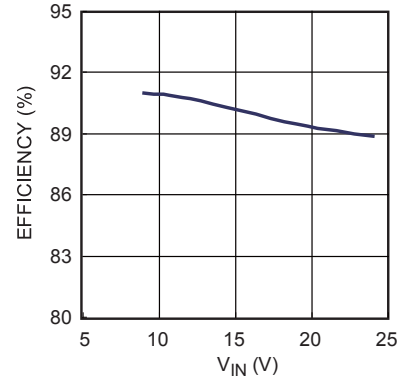


BATT Float Voltage vs. V_IN



Efficiency vs. V_IN

2-Cell, $V_{BATT}=7.4V$, CC Load

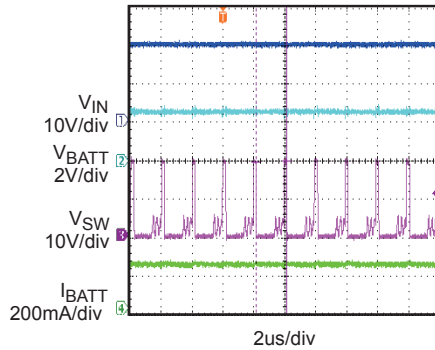


TYPICAL PERFORMANCE CHARACTERISTICS (continued)

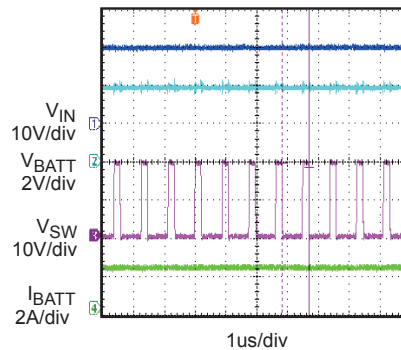
$V_{IN}=19V$, $C1=4.7\mu F$, $C2=22\mu F$, $L=4.7\mu H$, $RS1=100m\Omega$, Real Battery Load, $T_A=25^\circ C$, unless otherwise noted.

Steady State Waveform

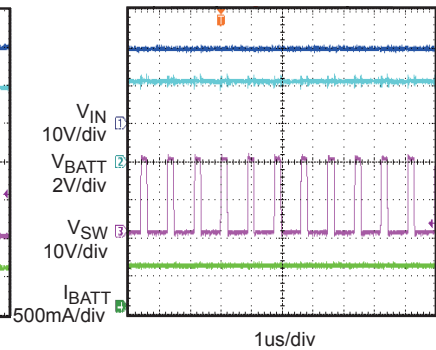
Trickle Charge

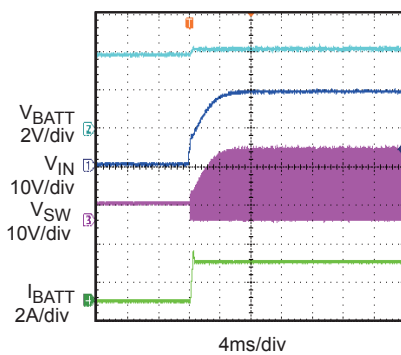
 1-Cell, $V_{BATT}=2.5V$, CV Load

Steady State Waveform

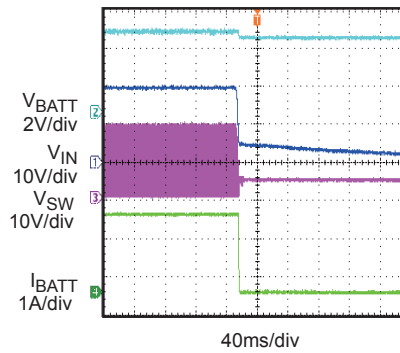
CC Change

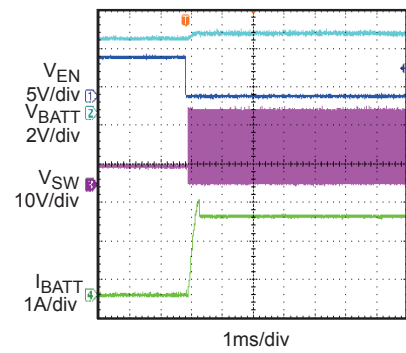
 1-Cell, $V_{BATT}=3.8V$, CV Load

Steady State Waveform

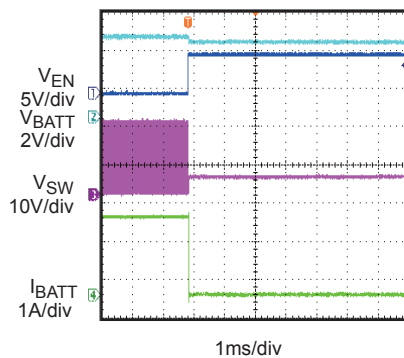
CV Change

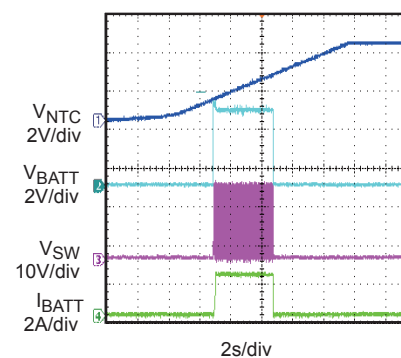
 1-Cell, $V_{BATT}=4.1V$, CV Load

Power On Waveform

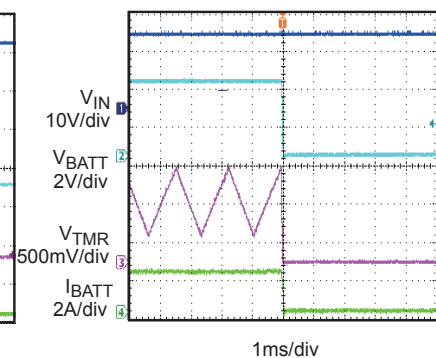
 1-Cell, $I_{CHG}=2A$, $V_{BATT}=4V$

Power Off Waveform

 1-Cell, $I_{CHG}=2A$, $V_{BATT}=4V$

EN On Waveform

 1-Cell, $I_{CHG}=2A$, $V_{BATT}=4V$

EN Off Waveform

 1-Cell, $I_{CHG}=2A$, $V_{BATT}=4V$

NTC Control

 1-Cell, $V_{BATT}=3.8V$, CV Load

Time Out

 1-Cell, $V_{BATT}=3.8V$, CV Load, $C_{TMR}=1nF$


FUNCTIONAL BLOCK DIAGRAM

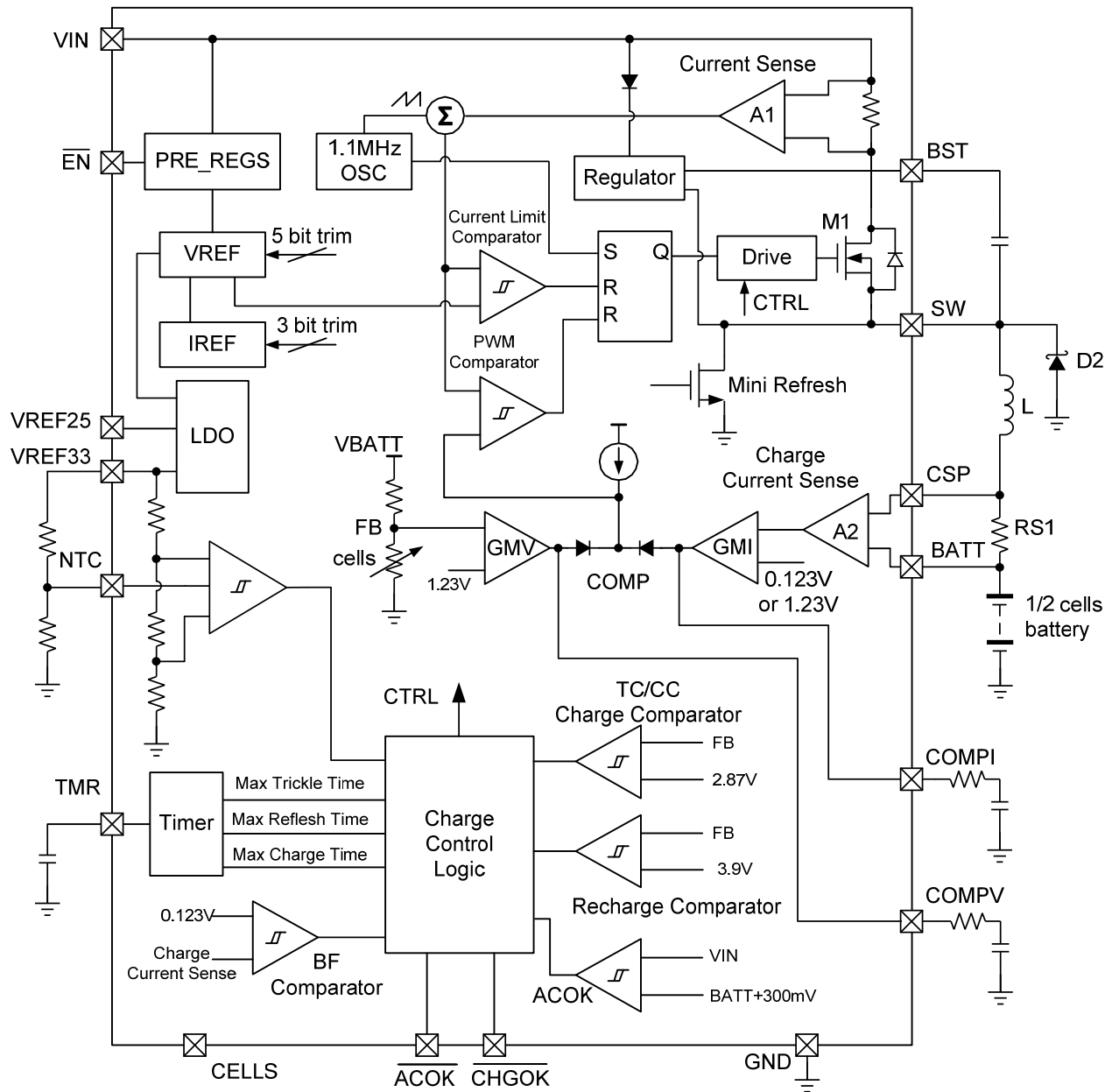


Figure 1—Functional Block Diagram

OPERATION

The MP26101 is a peak-current-mode controlled switching charger for 1- or 2-cell Li-Ion batteries.

Figure 1 shows the block diagram. At the beginning of a cycle, M1 is off. The COMP voltage is higher than the output of the current sense amplifier (A1) and the PWM comparator's output is low. The rising edge of the 1.1MHz CLK signal sets the RS flip-flop. Its output turns on M1 to connect the SW pin and inductor to the input supply.

A1 senses and amplifies the inductor current: The PWM comparator then compares the sum of this signal and the ramp compensator signal against the COMP signal. When the sum of the A1 output and the ramp compensator exceeds the COMP voltage, the RS flip-flop reset and turns M1 off. The external switching diode (D2) then conducts the inductor current. If the sum of the A1 output and the ramp compensator does not exceed the COMP voltage, then the falling edge of the CLK resets the flip-flop.

The MP26101 has two linear regulators, VREF33 and VREF25, that power the internal circuit. The 3.3V reference can power external circuitry as long as the current does not exceed 50mA. Add a 1µF bypass capacitor from VREF33 to GND to ensure stability. By comparison, the 2.5V reference regulator can not carry any significant load,.

For most applications, leave VREF25 floating without a bypass capacitor. Otherwise, connect a capacitor with a value less than 100pF.

Charge Cycle (Mode Change: Trickle → Constant Current → Constant Voltage)

The MP26101 senses battery current through the amplified voltage drop across RS1 (Figure 1). The charging starts in trickle-charge mode (10% of the RS1-programmed current I_{CC}) until the battery voltage reaches 2.87V/cell. If the charge stays in trickle-charging mode until the trickle-charge time limit, the device shuts down. Otherwise, the MP26101 operates in constant-current (CC) mode and regulates the output current to a level set by RS1. The COMP1 voltage (regulated by the

amplifier GMI) determines the switching duty cycle .

When the battery voltage reaches the constant voltage (CV) mode threshold, the amplifier GMV regulates the COMPV pin and the duty cycle.

Automatic Recharge

The charger will cease charging and the $\overline{\text{CHGOK}}$ pin becomes an open drain output if the battery charging current drops below the termination threshold for more than one minute. If the battery voltage drops to 3.9V/Cell, the MP26101 automatically begins recharging the battery.

Charger Status Indication

MP26101 has two open-drain status outputs, $\overline{\text{CHGOK}}$ and $\overline{\text{ACOK}}$. The $\overline{\text{ACOK}}$ pin pulls low when an input voltage is 300mV over the battery voltage and over the under voltage lockout threshold. $\overline{\text{CHGOK}}$ indicates the status of the charge cycle. Table 1 describes the status of the charge cycle based on the $\overline{\text{CHGOK}}$ and $\overline{\text{ACOK}}$ outputs.

Table 1—Charging Status Indication

$\overline{\text{ACOK}}$	$\overline{\text{CHGOK}}$	Charger status
low	low	In charging
low	high	End of charge
high	high	$V_{in} < UVLO$, thermal shutdown, timer out, $\overline{\text{EN}}$ disable

Timer Operation

MP26101 uses an internal timer to terminate charging. An external capacitor programs timer duration at the TMR pin.

The trickle mode charge time is:

$$t_{\text{TICKLE_TMR}} = 30 \text{ mins} \times \frac{C_{\text{TMR}}}{0.1\mu\text{F}}$$

The total charge time is:

$$t_{\text{TOTAL_TMR}} = 3 \text{ hours} \times \frac{C_{\text{TMR}}}{0.1\mu\text{F}}$$

Negative Thermal Coefficient (NTC) Thermistor

The MP26101 has a built-in NTC resistance window comparator that allows MP26101 to measure the temperature through a thermistor in the battery pack that ensures that the battery operates under recommended conditions.

Connect an appropriate resistor from VREF33 to the NTC pin, and connect the thermistor from the NTC pin to GND. The voltage on the NTC pin is determined by the temperature-sensitive resistor divider. When the NTC voltage falls out of NTC window range, MP26101 will stop the charging. The charger will restart if the temperature goes back into NTC window range.

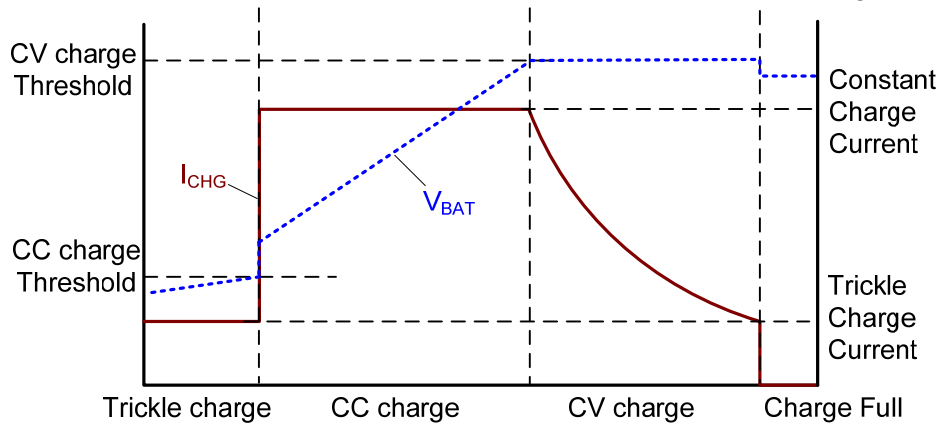
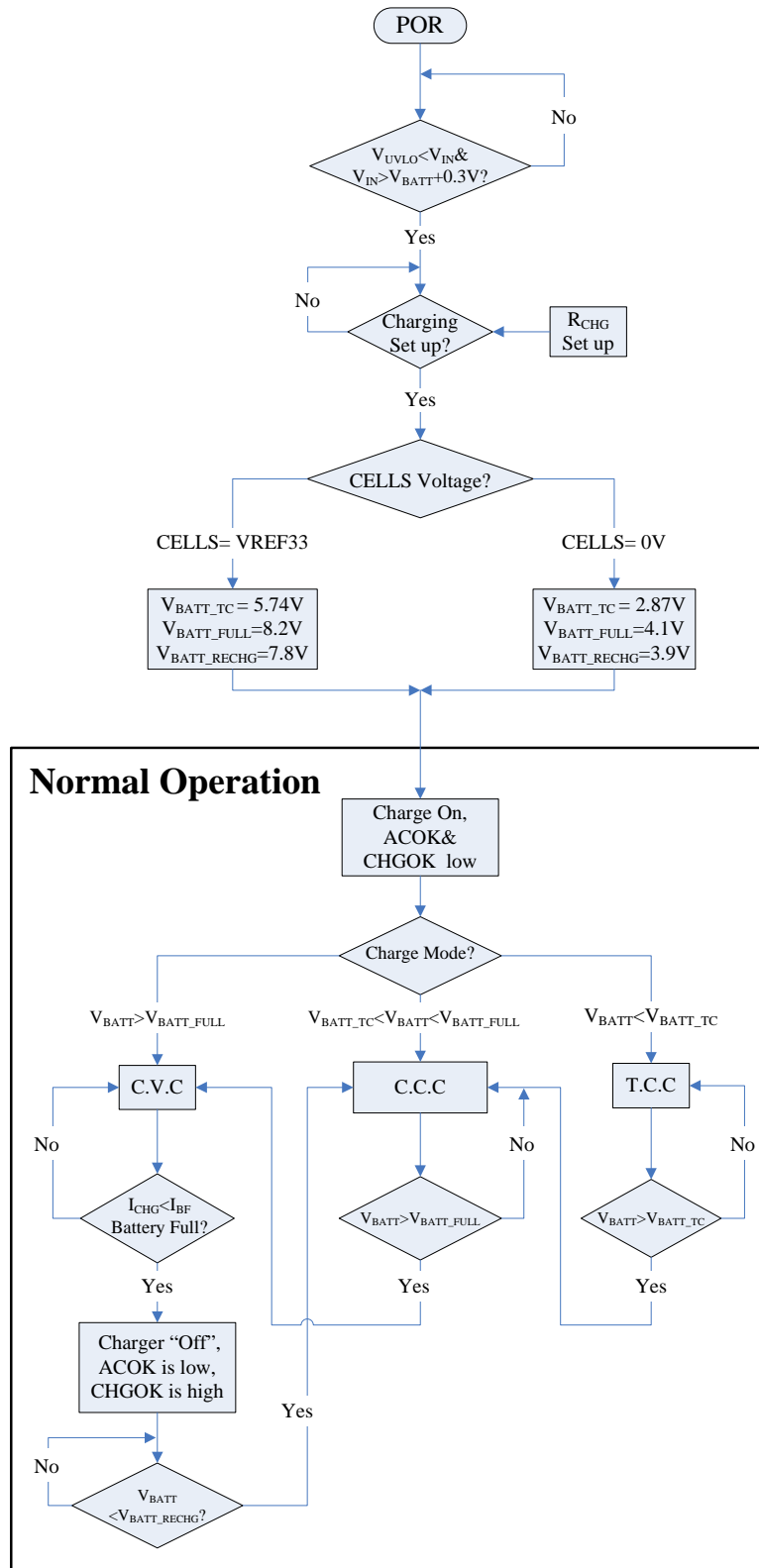
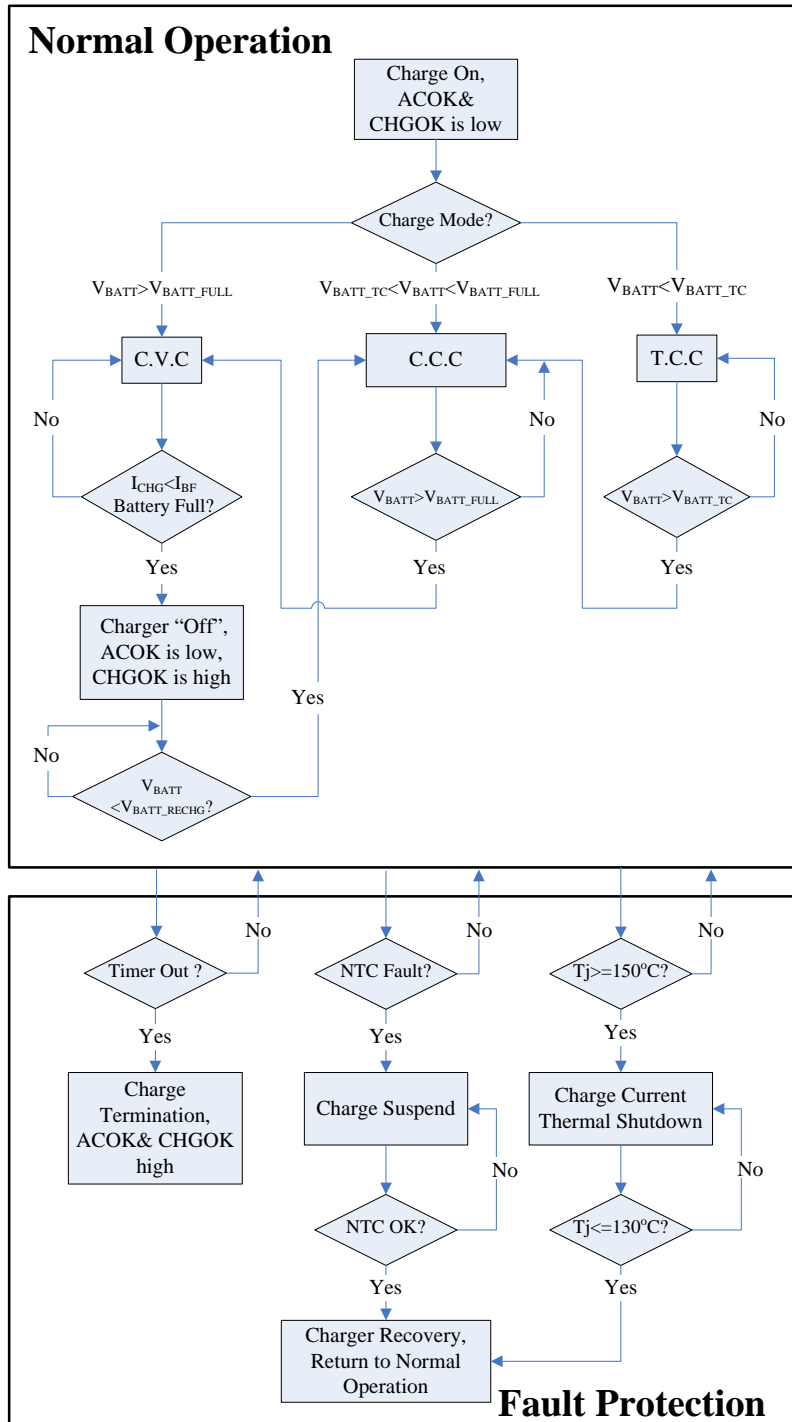


Figure 2—Li-Ion Battery Charge Profile


Figure 3— Normal Charging Operation Flow Chart


Figure 4— Fault Protection Flow Chart

APPLICATION INFORMATION

Setting the Charge Current

The sense resistor RS1 sets the charge current as per the following equation:

$$I_{CHG} (A) = \frac{200mV}{RS1(m\Omega)} \quad (1)$$

Table2— I_{CHG} Setting

$I_{CHG}(A)$	$RS(m\Omega)$
2	100
1.5	133
1	200
0.8	250
0.5	400

Selecting the Inductor

Select an inductor with a typical value between $1\mu H$ and $10\mu H$ using the following equation.

$$L = \frac{V_{OUT} \times (V_{IN} - V_{OUT})}{V_{IN} \times \Delta I_L \times f_{OSC}} \quad (2)$$

Where ΔI_L is the inductor ripple current. V_{OUT} is the battery voltage.

Choose an inductor current equal to approximately 30% of the maximum charge current, 2A. The maximum inductor peak current is:

$$I_{L(MAX)} = I_{LOAD} + \frac{\Delta I_L}{2} \quad (3)$$

Under light load conditions below 100mA, use a larger inductance to improve efficiency. For most applications, chose an inductor with a DC resistance less than 200m Ω .

NTC Function

As Figure 5 shows, the low temperature threshold and high temperature threshold are preset internally through a resistive divider set at $73.5\% \cdot VREF33$ and $29.5\% \cdot VREF33$. For a given NTC thermistor, we can select an appropriate R3 and an appropriate R6 to set the NTC window.

For example, using the NCP18XH103 thermistor,

At $0^\circ C$, $R_{NTC_Cold} = 27.445k$;

At $50^\circ C$, $R_{NTC_Hot} = 4.1601k$.

Assuming that the NTC window is between $0^\circ C$

and $50^\circ C$, and given the following equations:

$$\frac{R6 // R_{NTC_Cold}}{R3 + R6 // R_{NTC_Cold}} = \frac{V_{TH_Low}}{VREF33} = 73.5\% \quad (4)$$

$$\frac{R6 // R_{NTC_Hot}}{R3 + R6 // R_{NTC_Hot}} = \frac{V_{TH_High}}{VREF33} = 29.5\% \quad (5)$$

$R3 = 9.63k$ and $R6 = 505k$. Simplifying, select $R3=10k$ and leave R6 open to satisfy the specifications.

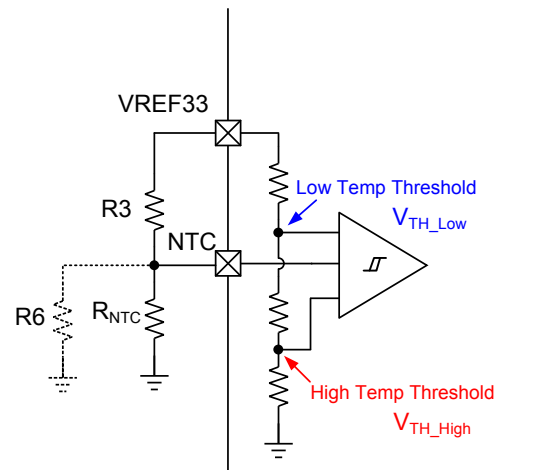


Figure 5— NTC function block

Selecting the Input Capacitor

The input capacitor reduces the surge current drawn from the input and the switching noise from the device. Choose an input capacitor with a switching frequency impedance less than the input source impedance to prevent high-frequency switching current from flowing to the input. Use ceramic capacitors with X5R or X7R dielectrics with low ESR and small temperature coefficients. For most applications, use a $4.7\mu F$ capacitor.

Selecting the Output Capacitor

The output capacitor limits the output voltage ripple and ensures regulator loop stability. The output capacitor impedance should be low at the switching frequency. Use ceramic capacitors with X5R or X7R dielectrics.

PC Board Layout

Route the high frequency and high current paths (GND, IN and SW) to the device using short, direct, and wide traces. Place the input capacitor

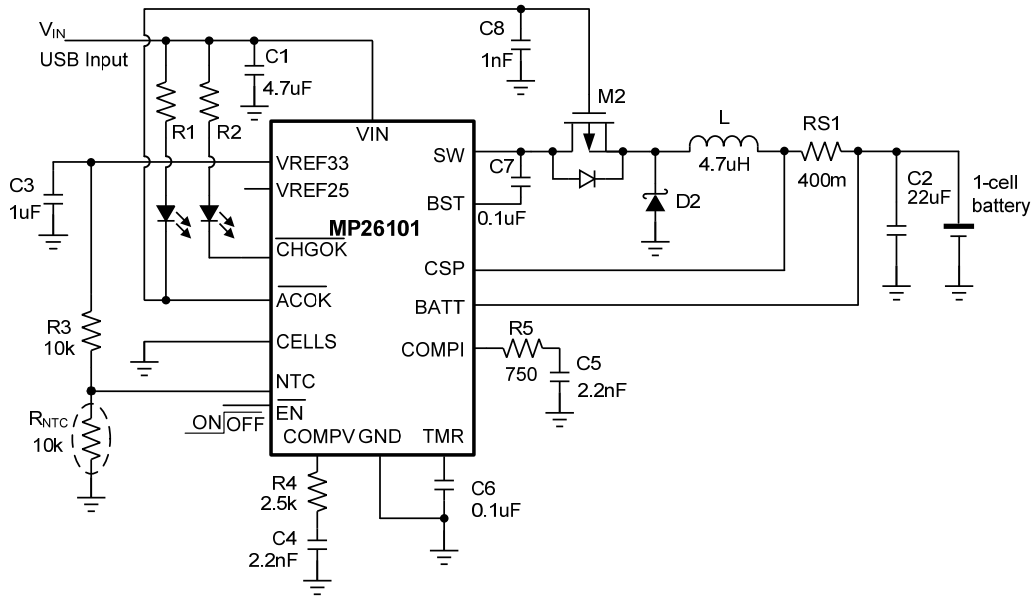
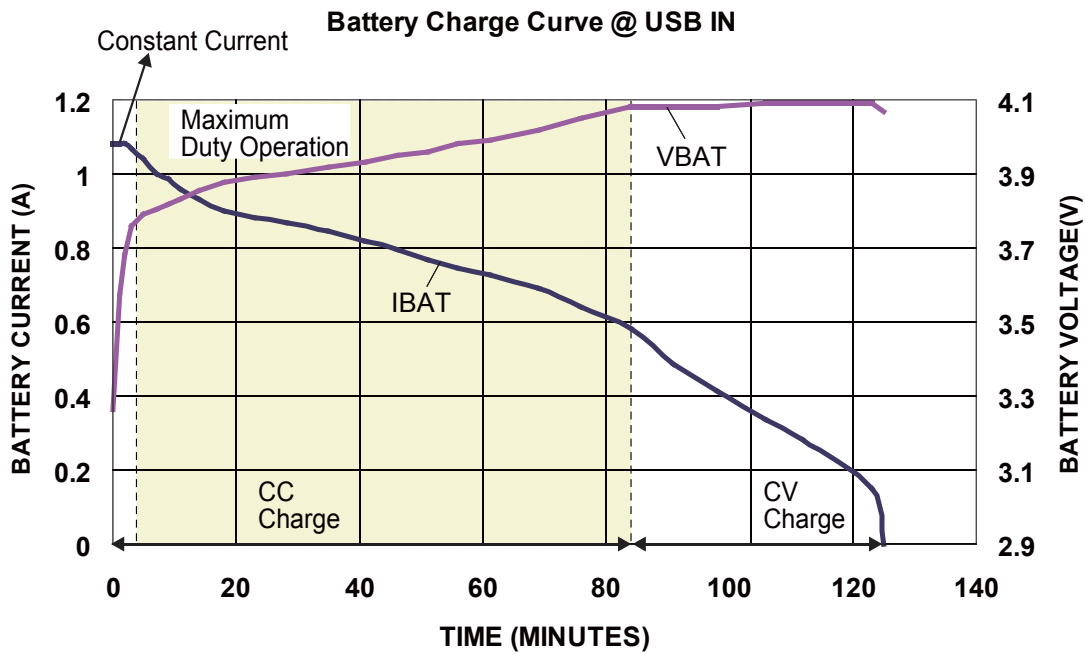
as close as possible to the VIN and GND pins. Place the external feedback resistors next to the FB pin. Keep the switching node SW short and away from the feedback network.

USB Input Application

Use the typical application circuit in Figure 6 for USB charging. Use one PMOS instead of the block diode D1 to limit the voltage drop, and to realize smaller minimum input charging to a single-cell battery. The charge current is set to be

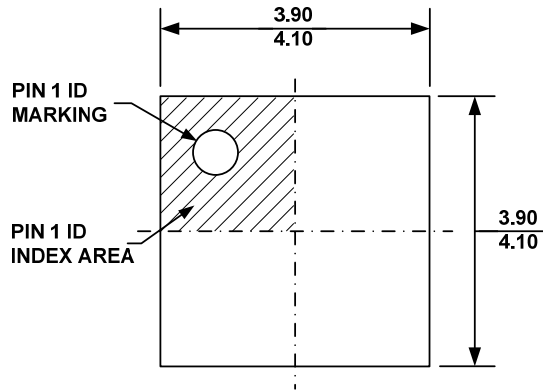
1A to satisfy turbo USB or $5V_{IN}$ Wall-Adapter requirements and to realize fast charging.

Figure 7 is the typical charging curve. The charge current cannot remain constant at the setting value during the operation at the constant current charging mode: It drops at the device's maximum duty. Use a lower charge current to extend the constant current charge duration. This feature makes the MP26101 suitable for USB charging.

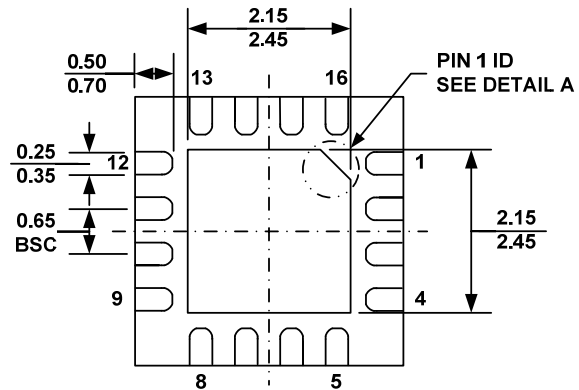

Figure 6— Typical Application Circuit for USB Input

Figure 7— Battery Charge Curve @ USB In

PACKAGE INFORMATION

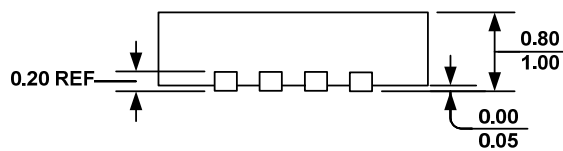
QFN16 (4 x 4mm)



TOP VIEW

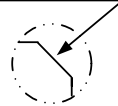


BOTTOM VIEW

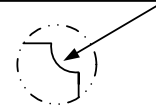


SIDE VIEW

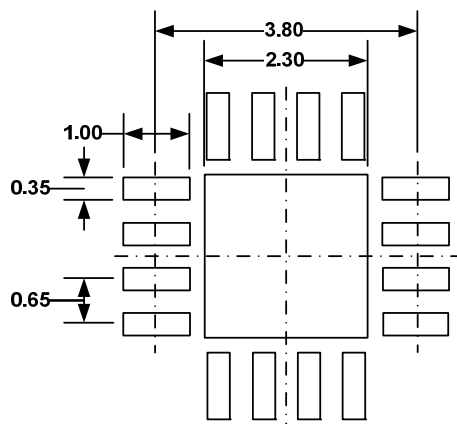
PIN 1 ID OPTION A
0.45x45° TYP.



PIN 1 ID OPTION B
R0.25 TYP.



DETAIL A



RECOMMENDED LAND PATTERN

NOTE:

- 1) ALL DIMENSIONS ARE IN MILLIMETERS.
- 2) EXPOSED PADDLE SIZE DOES NOT INCLUDE MOLD FLASH.
- 3) LEAD COPLANARITY SHALL BE 0.10 MILLIMETER MAX.
- 4) JEDEC REFERENCE IS MO-220, VARIATION VGGC.
- 5) DRAWING IS NOT TO SCALE.

NOTICE: The information in this document is subject to change without notice. Users should warrant and guarantee that third party Intellectual Property rights are not infringed upon when integrating MPS products into any application. MPS will not assume any legal responsibility for any said applications.

Looking for pricing, stock, or lifecycle information?

Click below to explore more details on WIN SOURCE:

- ⊖ [View MP26101DR-LF-Z on WIN SOURCE](#)
- ⊖ [Monolithic Power Systems Inc. Information](#)

Optimize Your Supply Chain with WIN SOURCE Solutions

- ✓ Global Sourcing Solution
- ✓ Obsolete Management
- ✓ Cost Control Management
- ✓ Shortage Management
- ✓ Alternative Solution
- ✓ Excess Inventory Management