



**THE DATASHEET OF
AD9513BCPZ-REEL7**



FEATURES

- 1.6 GHz differential clock input**
- 3 programmable dividers**
 - Divide-by in range from 1 to 32
 - Phase select for coarse delay adjust
- Three 800 MHz/250 MHz LVDS/CMOS clock outputs**
 - Additive output jitter 300 fs rms
 - Time delays up to 11.6 ns
- Device configured with 4-level logic pins**
- Space-saving, 32-lead LFCSP**

APPLICATIONS

- Low jitter, low phase noise clock distribution**
- Clocking high speed ADCs, DACs, DDSs, DDCs, DUCs, MxFEs**
- High performance wireless transceivers**
- High performance instrumentation**
- Broadband infrastructure**
- ATE**

GENERAL DESCRIPTION

The AD9513 features a three-output clock distribution IC in a design that emphasizes low jitter and phase noise to maximize data converter performance. Other applications with demanding phase noise and jitter requirements also benefit from this part.

There are three independent clock outputs that can be set to either LVDS or CMOS levels. These outputs operate to 800 MHz in LVDS mode and to 250 MHz in CMOS mode.

Each output has a programmable divider that can be set to divide by a selected set of integers ranging from 1 to 32. The phase of one clock output relative to the other clock output can be set by means of a divider phase select function that serves as a coarse timing adjustment.

FUNCTIONAL BLOCK DIAGRAM

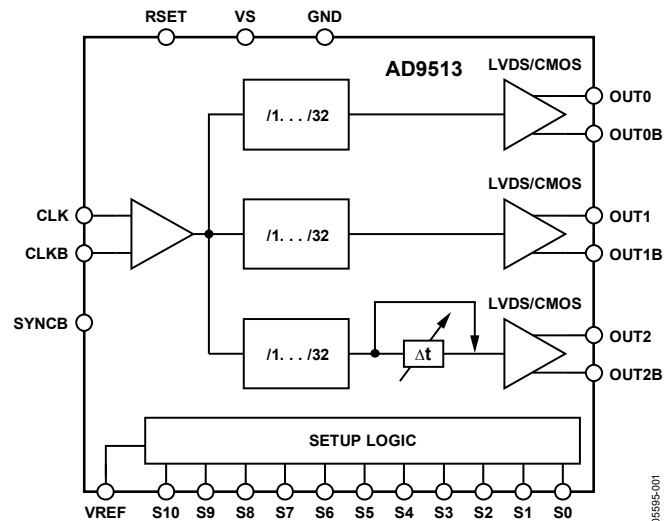

Figure 1.

One of the outputs features a delay element with three selectable full-scale delay values (1.8 ns, 6.0 ns, and 11.6 ns), each with 16 steps of fine adjustment.

The AD9513 does not require an external controller for operation or setup. The device is programmed by means of 11 pins (S0 to S10) using 4-level logic. The programming pins are internally biased to $\frac{1}{3} V_s$. The VREF pin provides a level of $\frac{2}{3} V_s$. V_s (3.3 V) and GND (0 V) provide the other two logic levels.

The AD9513 is ideally suited for data converter clocking applications where maximum converter performance is achieved by encode signals with subpicosecond jitter.

The AD9513 is available in a 32-lead LFCSP and operates from a single 3.3 V supply. The temperature range is -40°C to $+85^\circ\text{C}$.

TABLE OF CONTENTS

| | | | |
|---|----|--|----|
| Features | 1 | Power-On SYNC | 17 |
| Applications | 1 | SYNCB | 17 |
| Functional Block Diagram | 1 | RSET Resistor | 18 |
| General Description | 1 | VREF | 18 |
| Revision History | 2 | Setup Configuration | 18 |
| Specifications | 3 | Divider Phase Offset | 20 |
| Clock Input | 3 | Delay Block | 21 |
| Clock Outputs | 3 | Outputs | 21 |
| Timing Characteristics | 4 | Power Supply | 22 |
| Clock Output Phase Noise | 6 | Exposed Metal Paddle | 22 |
| Clock Output Additive Time Jitter | 8 | Power Management | 22 |
| SYNCB, VREF, and Setup Pins | 9 | Applications Information | 23 |
| Power | 9 | Using the AD9513 Outputs for ADC Clock Applications ... | 23 |
| Timing Diagrams | 10 | LVDS Clock Distribution | 23 |
| Absolute Maximum Ratings | 11 | CMOS Clock Distribution | 23 |
| Thermal Characteristics ¹ | 11 | Setup Pins (S0 to S10) | 24 |
| Pin Configuration and Function Descriptions | 12 | Power and Grounding Considerations and Power Supply Rejection | 24 |
| Terminology | 13 | Phase Noise and Jitter Measurement Setups | 25 |
| Typical Performance Characteristics | 14 | Outline Dimensions | 26 |
| Functional Description | 17 | Ordering Guide | 26 |
| Overall | 17 | | |
| CLK, CLKB—Differential Clock Input | 17 | | |
| Synchronization | 17 | | |

REVISION HISTORY

11/2020—Rev. B to Rev. C

| | |
|----------------------------------|------------|
| Changed CP-32-2 to CP-32-7 | Throughout |
| Changes to Figure 5 | 12 |
| Updated Outline Dimensions | 26 |
| Changes to Ordering Guide | 26 |

10/2017—Rev. A to Rev. B

| | |
|----------------------------------|------------|
| Changed CP-32-7 to CP-32-2 | Throughout |
| Updated Outline Dimensions | 26 |
| Changes to Ordering Guide | 26 |

1/2017—Rev. 0 to Rev. A

| | |
|---|----|
| Changes to Figure 5 and Table 9 | 12 |
| Deleted Figure 6; Renumbered Sequentially | 12 |
| Change to Table 14 | 19 |
| Updated Outline Dimensions | 26 |
| Changes to Ordering Guide | 26 |

9/2005—Revision 0: Initial Version

SPECIFICATIONS

Typical (typ) is given for $V_S = 3.3 \text{ V} \pm 5\%$; $T_A = 25^\circ\text{C}$, $R_{SET} = 4.12 \text{ k}\Omega$, unless otherwise noted. Minimum (min) and maximum (max) values are given over full V_S and T_A (-40°C to $+85^\circ\text{C}$) variation.

CLOCK INPUT

Table 1.

| Parameter | Min | Typ | Max | Unit | Test Conditions/Comments |
|-------------------------------------|-----|-----|-----|------------|---|
| CLOCK INPUT (CLK) | | | | | |
| Input Frequency | 0 | | 1.6 | GHz | |
| Input Sensitivity ¹ | | 150 | | mV p-p | |
| Input Common-Mode Voltage, V_{CM} | 1.5 | 1.6 | 1.7 | V | Self-biased; enables ac coupling |
| Input Common-Mode Range, V_{CMR} | 1.3 | | 1.8 | V | With 200 mV p-p signal applied; dc-coupled |
| Input Sensitivity, Single-Ended | | 150 | | mV p-p | CLK ac-coupled; CLKB ac-bypassed to RF ground |
| Input Resistance | 4.0 | 4.8 | 5.6 | k Ω | Self-biased |
| Input Capacitance | | 2 | | pF | |

¹A slew rate of 1 V/ns is required to meet jitter, phase noise, and propagation delay specifications.

CLOCK OUTPUTS

Table 2.

| Parameter | Min | Typ | Max | Unit | Test Conditions/Comments |
|---|-------------|------|-------|------|---|
| LVDS CLOCK OUTPUT | | | | | Termination = 100 Ω differential |
| Differential | | | | | |
| Output Frequency | 0 | | 800 | MHz | |
| Differential Output Voltage (V_{OD}) | 250 | 350 | 450 | mV | |
| Delta V_{OD} | | | 30 | mV | |
| Output Offset Voltage (V_{OS}) | 1.125 | 1.23 | 1.375 | V | |
| Delta V_{OS} | | | 25 | mV | |
| Short-Circuit Current (I_{SA} , I_{SB}) | | 14 | 24 | mA | Output shorted to GND |
| CMOS CLOCK OUTPUT | | | | | Single-ended measurements; termination open |
| Single-Ended | | | | | Complementary output on (OUT1B) |
| Output Frequency | 0 | | 250 | MHz | With 5 pF load |
| Output Voltage High (V_{OH}) | $V_S - 0.1$ | | | V | @ 1 mA load |
| Output Voltage Low (V_{OL}) | | | 0.1 | V | @ 1 mA load |

TIMING CHARACTERISTICS

CLK input slew rate = 1 V/ns or greater.

Table 3.

| Parameter | Min | Typ | Max | Unit | Test Conditions/Comments |
|---|------|-------|------|------------------|--|
| LVDS | | | | | Termination = 100 Ω differential |
| Output Rise Time, t_{RL} | | 200 | 350 | ps | 20% to 80%, measured differentially |
| Output Fall Time, t_{FL} | | 210 | 350 | ps | 80% to 20%, measured differentially |
| PROPAGATION DELAY, t_{LVDS} , CLK-TO-LVDS OUT OUT0, OUT1, OUT2 | | | | | Delay off on OUT2 |
| Divide = 1 | 1.03 | 1.29 | 1.62 | ns | |
| Divide = 2 – 32 | 1.09 | 1.35 | 1.68 | ns | |
| Variation with Temperature | | 0.9 | | ps/ $^{\circ}$ C | |
| OUT2 | | | | | |
| Divide = 1 | 1.07 | 1.35 | 1.69 | ns | |
| Divide = 2 – 32 | 1.13 | 1.41 | 1.75 | ns | |
| Variation with Temperature | | 0.9 | | ps/ $^{\circ}$ C | |
| OUTPUT SKEW, LVDS OUTPUTS | | | | | Delay off on OUT2 |
| OUT0 to OUT1 on Same Part, t_{SKV}^1 | -135 | -20 | +125 | ps | |
| OUT0 to OUT2 on Same Part, t_{SKV}^1 | -205 | -65 | +90 | ps | |
| All LVDS OUTs Across Multiple Parts, $t_{SKV_AB}^2$ | | | 375 | ps | |
| Same LVDS OUTs Across Multiple Parts, $t_{SKV_AB}^2$ | | | 300 | ps | |
| CMOS | | | | | B outputs are inverted; termination = open |
| Output Rise Time, t_{RC} | | 650 | 865 | ps | 20% to 80%; $C_{LOAD} = 3$ pF |
| Output Fall Time, t_{FC} | | 650 | 990 | ps | 80% to 20%; $C_{LOAD} = 3$ pF |
| PROPAGATION DELAY, t_{CMOS} , CLK-TO-CMOS OUT OUT0, OUT1 | | | | | Delay off on OUT2 |
| Divide = 1 | 1.14 | 1.46 | 1.89 | ns | |
| Divide = 2 – 32 | 1.19 | 1.51 | 1.94 | ns | |
| Variation with Temperature | | 1 | | ps/ $^{\circ}$ C | |
| OUT2 | | | | | |
| Divide = 1 | 1.20 | 1.53 | 1.97 | ns | |
| Divide = 2 – 32 | 1.24 | 1.57 | 2.01 | ns | |
| Variation with Temperature | | 1 | | ps/ $^{\circ}$ C | |
| OUTPUT SKEW, CMOS OUTPUTS | | | | | Delay off on OUT2 |
| All CMOS OUTs on Same Part, t_{SKC}^1 | -230 | | +135 | ps | |
| All CMOS OUTs Across Multiple Parts, $t_{SKC_AB}^2$ | | | 415 | ps | |
| Same CMOS OUTs Across Multiple Parts, $t_{SKC_AB}^2$ | | | 330 | ps | |
| LVDS-TO-CMOS OUT | | | | | Everything the same; different logic type |
| Output Skew, t_{SKV_C} | | | 510 | ps | LVDS to CMOS on same part |
| DELAY ADJUST (OUT2; LVDS AND CMOS) | | | | | |
| S0 = 1/3 | | | | | |
| Zero-Scale Delay Time ³ | | 0.35 | | ns | |
| Zero-Scale Variation with Temperature | | 0.20 | | ps/ $^{\circ}$ C | |
| Full-Scale Time Delay ³ | | 1.8 | | ns | |
| Full-Scale Variation with Temperature | | -0.38 | | ps/ $^{\circ}$ C | |
| S0 = 2/3 | | | | | |
| Zero-Scale Delay Time ³ | | 0.48 | | ns | |
| Zero-Scale Variation with Temperature | | 0.31 | | ps/ $^{\circ}$ C | |
| Full-Scale Time Delay ³ | | 6.0 | | ns | |
| Full-Scale Variation with Temperature | | -1.3 | | ps/ $^{\circ}$ C | |

| Parameter | Min | Typ | Max | Unit | Test Conditions/Comments |
|---------------------------------------|-----|------|-----|-------|--------------------------|
| S0 = 1 | | | | | |
| Zero-Scale Delay Time ³ | | 0.59 | | ns | |
| Zero-Scale Variation with Temperature | | 0.47 | | ps/°C | |
| Full-Scale Time Delay ³ | | 11.6 | | ns | |
| Full-Scale Variation with Temperature | | -5 | | ps/°C | |
| Linearity, DNL | | 0.2 | | LSB | |
| Linearity, INL | | 0.2 | | LSB | |

¹ This is the difference between any two similar delay paths within a single device operating at the same voltage and temperature.

² This is the difference between any two similar delay paths across multiple devices operating at the same voltage and temperature.

³ Incremental delay; does not include propagation delay.

CLOCK OUTPUT PHASE NOISE

Table 4.

| Parameter | Min | Typ | Max | Unit | Test Conditions/Comments |
|------------------------------------|-----|------|-----|--------|--------------------------|
| CLK-TO-LVDS ADDITIVE PHASE NOISE | | | | | |
| CLK = 622.08 MHz, OUT = 622.08 MHz | | | | | |
| Divide Ratio = 1 | | | | | |
| At 10 Hz Offset | | -100 | | dBc/Hz | |
| At 100 Hz Offset | | -110 | | dBc/Hz | |
| At 1 kHz Offset | | -118 | | dBc/Hz | |
| At 10 kHz Offset | | -129 | | dBc/Hz | |
| At 100 kHz Offset | | -135 | | dBc/Hz | |
| At 1 MHz Offset | | -140 | | dBc/Hz | |
| >10 MHz Offset | | -148 | | dBc/Hz | |
| CLK = 622.08 MHz, OUT = 155.52 MHz | | | | | |
| Divide Ratio = 4 | | | | | |
| At 10 Hz Offset | | -112 | | dBc/Hz | |
| At 100 Hz Offset | | -122 | | dBc/Hz | |
| At 1 kHz Offset | | -132 | | dBc/Hz | |
| At 10 kHz Offset | | -142 | | dBc/Hz | |
| At 100 kHz Offset | | -148 | | dBc/Hz | |
| At 1 MHz Offset | | -152 | | dBc/Hz | |
| >10 MHz Offset | | -155 | | dBc/Hz | |
| CLK = 491.52 MHz, OUT = 245.76 MHz | | | | | |
| Divide Ratio = 2 | | | | | |
| At 10 Hz Offset | | -108 | | dBc/Hz | |
| At 100 Hz Offset | | -118 | | dBc/Hz | |
| At 1 kHz Offset | | -128 | | dBc/Hz | |
| At 10 kHz Offset | | -138 | | dBc/Hz | |
| At 100 kHz Offset | | -145 | | dBc/Hz | |
| At 1 MHz Offset | | -148 | | dBc/Hz | |
| >10 MHz Offset | | -154 | | dBc/Hz | |
| CLK = 491.52 MHz, OUT = 122.88 MHz | | | | | |
| Divide Ratio = 4 | | | | | |
| At 10 Hz Offset | | -118 | | dBc/Hz | |
| At 100 Hz Offset | | -129 | | dBc/Hz | |
| At 1 kHz Offset | | -136 | | dBc/Hz | |
| At 10 kHz Offset | | -147 | | dBc/Hz | |
| At 100 kHz Offset | | -153 | | dBc/Hz | |
| At 1 MHz Offset | | -156 | | dBc/Hz | |
| >10 MHz Offset | | -158 | | dBc/Hz | |
| CLK = 245.76 MHz, OUT = 245.76 MHz | | | | | |
| Divide Ratio = 1 | | | | | |
| At 10 Hz Offset | | -108 | | dBc/Hz | |
| At 100 Hz Offset | | -118 | | dBc/Hz | |
| At 1 kHz Offset | | -128 | | dBc/Hz | |
| At 10 kHz Offset | | -138 | | dBc/Hz | |
| At 100 kHz Offset | | -145 | | dBc/Hz | |
| @ 1 MHz Offset | | -148 | | dBc/Hz | |
| >10 MHz Offset | | -155 | | dBc/Hz | |

| Parameter | Min | Typ | Max | Unit | Test Conditions/Comments |
|--|-----|------|-----|--------|--------------------------|
| CLK = 245.76 MHz, OUT = 122.88 MHz Divide Ratio = 2 | | | | | |
| At 10 Hz Offset | | -118 | | dBc/Hz | |
| At 100 Hz Offset | | -127 | | dBc/Hz | |
| At 1 kHz Offset | | -137 | | dBc/Hz | |
| At 10 kHz Offset | | -147 | | dBc/Hz | |
| At 100 kHz Offset | | -154 | | dBc/Hz | |
| At 1 MHz Offset | | -156 | | dBc/Hz | |
| >10 MHz Offset | | -158 | | dBc/Hz | |
| CLK-TO-CMOS ADDITIVE PHASE NOISE | | | | | |
| CLK = 245.76 MHz, OUT = 245.76 MHz Divide Ratio = 1 | | | | | |
| At 10 Hz Offset | | -110 | | dBc/Hz | |
| At 100 Hz Offset | | -121 | | dBc/Hz | |
| At 1 kHz Offset | | -130 | | dBc/Hz | |
| At 10 kHz Offset | | -140 | | dBc/Hz | |
| At 100 kHz Offset | | -145 | | dBc/Hz | |
| At 1 MHz Offset | | -149 | | dBc/Hz | |
| >10 MHz Offset | | -156 | | dBc/Hz | |
| CLK = 245.76 MHz, OUT = 61.44 MHz Divide Ratio = 4 | | | | | |
| At 10 Hz Offset | | -125 | | dBc/Hz | |
| At 100 Hz Offset | | -132 | | dBc/Hz | |
| At 1 kHz Offset | | -143 | | dBc/Hz | |
| At 10 kHz Offset | | -152 | | dBc/Hz | |
| At 100 kHz Offset | | -158 | | dBc/Hz | |
| At 1 MHz Offset | | -160 | | dBc/Hz | |
| >10 MHz Offset | | -162 | | dBc/Hz | |
| CLK = 78.6432 MHz, OUT = 78.6432 MHz Divide Ratio = 1 | | | | | |
| At 10 Hz Offset | | -122 | | dBc/Hz | |
| At 100 Hz Offset | | -132 | | dBc/Hz | |
| At 1 kHz Offset | | -140 | | dBc/Hz | |
| At 10 kHz Offset | | -150 | | dBc/Hz | |
| At 100 kHz Offset | | -155 | | dBc/Hz | |
| At 1 MHz Offset | | -158 | | dBc/Hz | |
| >10 MHz Offset | | -160 | | dBc/Hz | |
| CLK = 78.6432 MHz, OUT = 39.3216 MHz Divide Ratio = 2 | | | | | |
| At 10 Hz Offset | | -128 | | dBc/Hz | |
| At 100 Hz Offset | | -136 | | dBc/Hz | |
| At 1 kHz Offset | | -146 | | dBc/Hz | |
| At 10 kHz Offset | | -155 | | dBc/Hz | |
| At 100 kHz Offset | | -161 | | dBc/Hz | |
| >1 MHz Offset | | -162 | | dBc/Hz | |

CLOCK OUTPUT ADDITIVE TIME JITTER

Table 5.

| Parameter | Min | Typ | Max | Unit | Test Conditions/Comments |
|---|-----|-----|-----|--------|-----------------------------------|
| LVDS OUTPUT ADDITIVE TIME JITTER | | | | | Calculated from SNR of ADC method |
| CLK= 400 MHz LVDS (OUT0) = 100 MHz Divide Ratio = 4 LVDS (OUT1, OUT2) = 100 MHz | | 300 | | fs rms | Interferer |
| CLK = 400 MHz LVDS (OUT0) = 100 MHz Divide Ratio = 4 LVDS (OUT1, OUT2) = 50 MHz | | 300 | | fs rms | Interferer |
| CLK = 400 MHz LVDS (OUT1) = 100 MHz Divide Ratio = 4 LVDS (OUT0, OUT2) = 100 MHz | | 305 | | fs rms | Interferer |
| CLK = 400 MHz LVDS (OUT1) = 100 MHz Divide Ratio = 4 LVDS (OUT0, OUT2) = 50 MHz | | 310 | | fs rms | Interferer |
| CLK = 400 MHz LVDS (OUT2) = 100 MHz Divide Ratio = 4 LVDS (OUT0, OUT1) = 100 MHz | | 310 | | fs rms | Interferer |
| CLK = 400 MHz LVDS (OUT2) = 100 MHz Divide Ratio = 4 LVDS (OUT0, OUT1) = 50 MHz | | 315 | | fs rms | Interferer |
| CLK = 400 MHz LVDS (OUT2) = 100 MHz Divide Ratio = 4 CMOS (OUT0, OUT1) = 50 MHz | | 345 | | fs rms | Interferer |
| CMOS OUTPUT ADDITIVE TIME JITTER | | | | | Calculated from SNR of ADC method |
| CLK = 400 MHz CMOS (OUT0) = 100 MHz Divide Ratio = 4 LVDS (OUT2) = 100 MHz | | 300 | | fs rms | Interferer |
| CLK = 400 MHz CMOS (OUT0) = 100 MHz Divide Ratio = 4 CMOS (OUT1, OUT2) = 50 MHz | | 300 | | fs rms | Interferer |
| CLK = 400 MHz CMOS (OUT1) = 100 MHz Divide Ratio = 4 CMOS (OUT0, OUT2) = 50 MHz | | 335 | | fs rms | Interferer |
| CLK = 400 MHz CMOS (OUT2) = 100 MHz Divide Ratio = 4 CMOS (OUT0, OUT1) = 50 MHz | | 355 | | fs rms | Interferer |
| CLK = 400 MHz CMOS (OUT2) = 100 MHz Divide Ratio = 4 LVDS (OUT0, OUT1) = 50 MHz | | 340 | | fs rms | Interferer |

| Parameter | Min | Typ | Max | Unit | Test Conditions/Comments |
|---|-----|------|-----|--------|--|
| DELAY BLOCK ADDITIVE TIME JITTER ¹ | | | | | 100 MHz output; incremental additive jitter ¹ |
| Delay FS = 1.8 ns Fine Adj. 00000 | | 0.71 | | ps rms | |
| Delay FS = 1.8 ns Fine Adj. 11111 | | 1.2 | | ps rms | |
| Delay FS = 6.0 ns Fine Adj. 00000 | | 1.3 | | ps rms | |
| Delay FS = 6.0 ns Fine Adj. 11111 | | 2.7 | | ps rms | |
| Delay FS = 11.6 ns Fine Adj. 00000 | | 2.0 | | ps rms | |
| Delay FS = 11.6 ns Fine Adj. 11111 | | 2.8 | | ps rms | |

¹ This value is incremental. That is, it is in addition to the jitter of the LVDS or CMOS output without the delay. To estimate the total jitter, the LVDS or CMOS output jitter should be added to this value using the root sum of the squares (RSS) method.

SYNCB, VREF, AND SETUP PINS

Table 6.

| Parameter | Min | Typ | Max | Unit | Test Conditions/Comments |
|----------------|---------------------|-----|---------------------|------|--|
| SYNCB | | | | | |
| Logic High | 2.7 | | | V | |
| Logic Low | | | 0.40 | V | |
| Capacitance | | 2 | | pF | |
| VREF | | | | | |
| Output Voltage | 0.62·V _S | | 0.76·V _S | V | Minimum – maximum from 0 mA to 1 mA load |
| S0 TO S10 | | | | | |
| Levels | | | | | |
| 0 | | | 0.1·V _S | V | |
| 1/3 | 0.2·V _S | | 0.45·V _S | V | |
| 2/3 | 0.55·V _S | | 0.8·V _S | V | |
| 1 | 0.9·V _S | | | V | |

POWER

Table 7.

| Parameter | Min | Typ | Max | Unit | Test Conditions/Comments |
|---|-----|-----|-----|------|---|
| POWER-ON SYNCHRONIZATION ¹ | | | 35 | ms | See the Power-On SYNC section. |
| V _S Transit Time from 2.2 V to 3.1 V | | | | | |
| POWER DISSIPATION | 175 | 325 | 575 | mW | All three outputs on. LVDS (divide = 2). No clock. Does not include power dissipated in external resistors. |
| | 240 | 460 | 615 | mW | All three outputs on. CMOS (divide = 2); 62.5 MHz out (5 pF load). |
| | 320 | 605 | 840 | mW | All three outputs on. CMOS (divide = 2); 125 MHz out (5 pF load). |
| POWER DELTA | | | | | |
| Divider (Divide = 2 to Divide = 1) | 15 | 30 | 45 | mW | For each divider. No clock. |
| LVDS Output | 20 | 50 | 85 | mW | No clock. |
| CMOS Output (Static) | 30 | 40 | 50 | mW | No clock. |
| CMOS Output (@ 62.5 MHz) | 65 | 110 | 155 | mW | Single-ended. At 62.5 MHz out with 5 pF load. |
| CMOS Output (@ 125 MHz) | 70 | 145 | 220 | mW | Single-ended. At 125 MHz out with 5 pF load. |
| Delay Block | 30 | 45 | 65 | mW | Off to 1.8 ns fs, delay word = 60; output clocking at 62.5 MHz. |

¹ This is the rise time of the V_S supply that is required to ensure that a synchronization of the outputs occurs on power-up. The critical factor is the time it takes the V_S to transition the range from 2.2 V to 3.1 V. If the rise time is too slow, the outputs are not synchronized.

TIMING DIAGRAMS

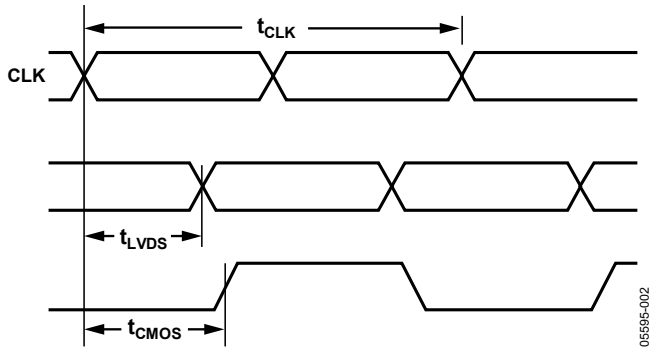

Figure 2. CLK/CLKB to Clock Output Timing, DIV = 1 Mode

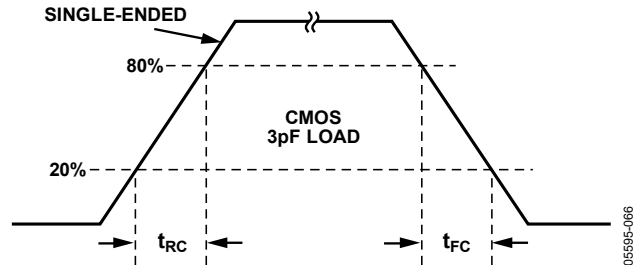

Figure 4. CMOS Timing, Single-Ended, 3 pF Load

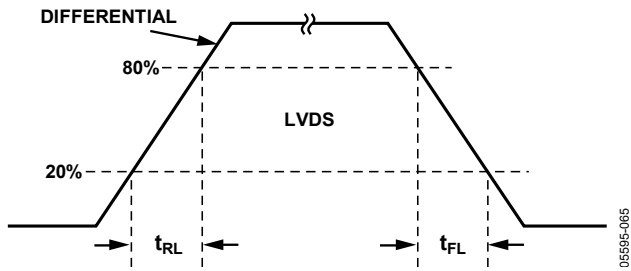

Figure 3. LVDS Timing, Differential

ABSOLUTE MAXIMUM RATINGS

Table 8.

| Parameter or Pin | With Respect to | Min Max | | Unit |
|-----------------------------------|-----------------|---------|-------------|------|
| | | Min | Max | |
| VS | GND | -0.3 | +3.6 | V |
| RSET | GND | -0.3 | $V_S + 0.3$ | V |
| CLK | GND | -0.3 | $V_S + 0.3$ | V |
| CLK | CLKB | -1.2 | +1.2 | V |
| OUT0, OUT1, OUT2 | GND | -0.3 | $V_S + 0.3$ | V |
| FUNCTION | GND | -0.3 | $V_S + 0.3$ | V |
| STATUS | GND | -0.3 | $V_S + 0.3$ | V |
| Junction Temperature ¹ | | | 150 | °C |
| Storage Temperature | | -65 | +150 | °C |
| Lead Temperature (10 sec) | | | 300 | °C |

¹ See Thermal Characteristics for θ_{JA} .

Stresses at or above those listed under Absolute Maximum Ratings may cause permanent damage to the product. This is a stress rating only; functional operation of the product at these or any other conditions above those indicated in the operational section of this specification is not implied. Operation beyond the maximum operating conditions for extended periods may affect product reliability.

THERMAL CHARACTERISTICS¹

Thermal Resistance²

32-Lead LFCSP

$$\theta_{JA} = 36.6^\circ\text{C}/\text{W}$$

¹ Thermal impedance measurements were taken on a 4-layer board in still air in accordance with EIA/JESD51-7.

² The external pad of this package must be soldered to adequate copper land on board.

PIN CONFIGURATION AND FUNCTION DESCRIPTIONS

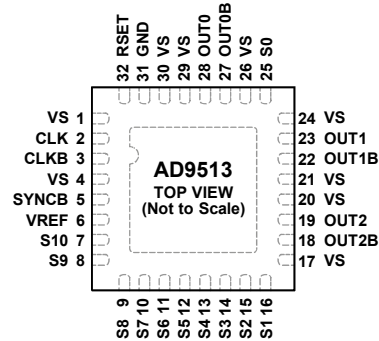

NOTES

1. EXPOSED PADDLE. THE EXPOSED PADDLE ON THIS PACKAGE IS AN ELECTRICAL CONNECTION AS WELL AS A THERMAL ENHANCEMENT. FOR THE DEVICE TO FUNCTION PROPERLY, THE PADDLE MUST BE SOLDERED TO A PCB LAND THAT FUNCTIONS AS BOTH A HEAT DISSIPATION PATH AS WELL AS AN ELECTRICAL GROUND.

0615915-005

Figure 5. 32-Lead LFCSP Pin Configuration

Table 9. Pin Function Descriptions

| Pin No. | Mnemonic | Description |
|----------------------------------|---------------|---|
| 1, 4, 17, 20, 21, 24, 26, 29, 30 | VS | Power Supply (3.3 V). |
| 2 | CLK | Clock Input. |
| 3 | CLKB | Complementary Clock Input. |
| 5 | SYNCB | Used to Synchronize Outputs. |
| 6 | VREF | Provides $2/3 V_S$ for use as one of the four logic levels on S0 to S10. |
| 7 to 16, 25 | S10 to S1, S0 | Setup Select Pins. These are 4-state logic. The logic levels are V_S , GND, $1/3 V_S$, and $2/3 V_S$. The VREF pin provides $2/3 V_S$. Each pin is internally biased to $1/3 V_S$ so that a pin requiring that logic level should be left NC (no connection). |
| 18 | OUT2B | Complementary LVDS/Inverted CMOS Output. |
| 19 | OUT2 | LVDS/CMOS Output. |
| 22 | OUT1B | Complementary LVDS/Inverted CMOS Output. |
| 23 | OUT1 | LVDS/CMOS Output. |
| 27 | OUT0B | Complementary LVDS/Inverted CMOS Output. |
| 28 | OUT0 | LVDS/CMOS Output. |
| 31 | GND | Ground. The exposed paddle on the back of the chip is also GND. |
| 32 | RSET | Current Set Resistor to Ground. Nominal value = 4.12 k Ω . |
| | EPAD | Exposed Paddle. The exposed paddle on this package is an electrical connection as well as a thermal enhancement. For the device to function properly, the paddle must be soldered to a PCB land that functions as both a heat dissipation path as well as an electrical ground. |

TERMINOLOGY

Phase Jitter and Phase Noise

An ideal sine wave can be thought of as having a continuous and even progression of phase with time from 0 to 360 degrees for each cycle. Actual signals, however, display a certain amount of variation from ideal phase progression over time. This phenomenon is called phase jitter. Although there are many causes that can contribute to phase jitter, one major component is due to random noise that is characterized statistically as being Gaussian (normal) in distribution.

This phase jitter leads to a spreading out of the energy of the sine wave in the frequency domain, producing a continuous power spectrum. This power spectrum is usually reported as a series of values whose units are dBc/Hz at a given offset in frequency from the sine wave (carrier). The value is a ratio (expressed in dB) of the power contained within a 1 Hz bandwidth with respect to the power at the carrier frequency. For each measurement, the offset from the carrier frequency is also given.

It is also meaningful to integrate the total power contained within some interval of offset frequencies (for example, 10 kHz to 10 MHz). This is called the integrated phase noise over that frequency offset interval and can be readily related to the time jitter due to the phase noise within that offset frequency interval.

Phase noise has a detrimental effect on the performance of ADCs, DACs, and RF mixers. It lowers the achievable dynamic range of the converters and mixers, although they are affected in somewhat different ways.

Time Jitter

Phase noise is a frequency domain phenomenon. In the time domain, the same effect is exhibited as time jitter. When observing a sine wave, the time of successive zero crossings is seen to vary. For a square wave, the time jitter is seen as a displacement of the edges from their ideal (regular) times of occurrence. In both cases, the variations in timing from the ideal are the time jitter. Since these variations are random in nature, the time jitter is specified in units of seconds root mean square (rms) or 1 sigma of the Gaussian distribution.

Time jitter that occurs on a sampling clock for a DAC or an ADC decreases the SNR and dynamic range of the converter. A sampling clock with the lowest possible jitter provides the highest performance from a given converter.

Additive Phase Noise

It is the amount of phase noise that is attributable to the device or subsystem being measured. The phase noise of any external oscillators or clock sources has been subtracted. This makes it possible to predict the degree to which the device as the total system phase noise when used in conjunction with the various oscillators and clock sources, each of which contribute their own phase noise to the total. In many cases, the phase noise of one element dominates the system phase noise.

Additive Time Jitter

It is the amount of time jitter that is attributable to the device or subsystem being measured. The time jitter of any external oscillators or clock sources has been subtracted. This makes it possible to predict the degree to which the device will affect the total system time jitter when used in conjunction with the various oscillators and clock sources, each of which contribute their own time jitter to the total. In many cases, the time jitter of the external oscillators and clock sources dominates the system time jitter.

TYPICAL PERFORMANCE CHARACTERISTICS

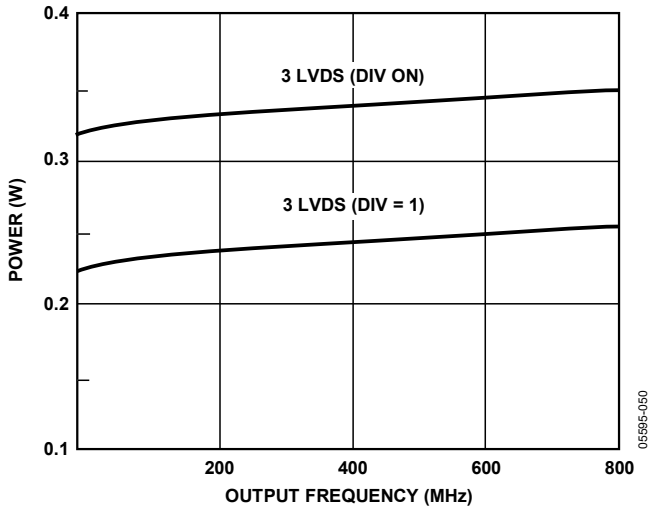

Figure 6. Power vs. Frequency—LVDS

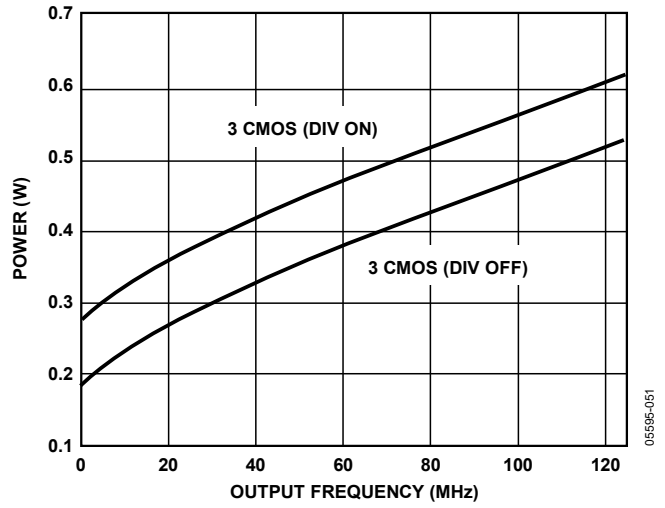
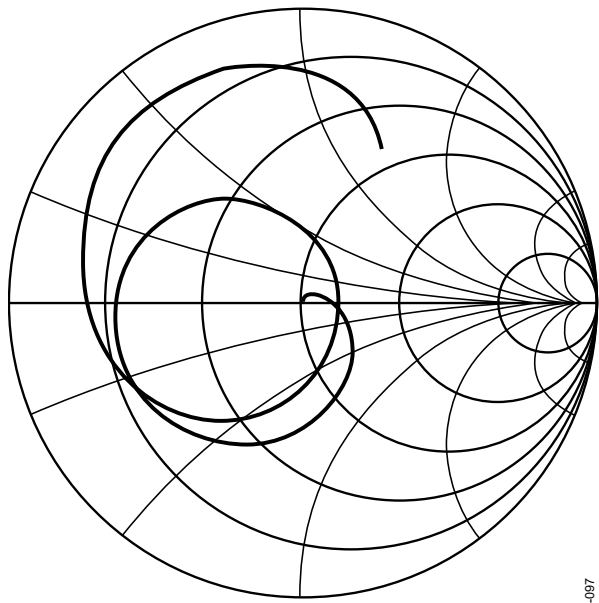

Figure 8. Power vs. Frequency—CMOS



START 300kHz STOP 5GHz
Figure 7. CLK Smith Chart (Evaluation Board)

05595-097

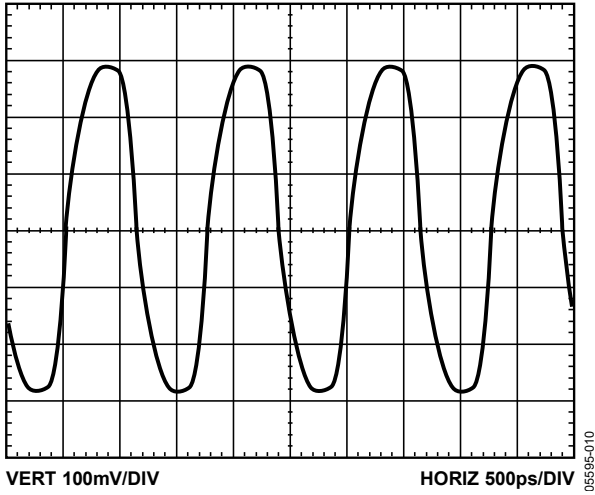

Figure 9. LVDS Differential Output at 800 MHz

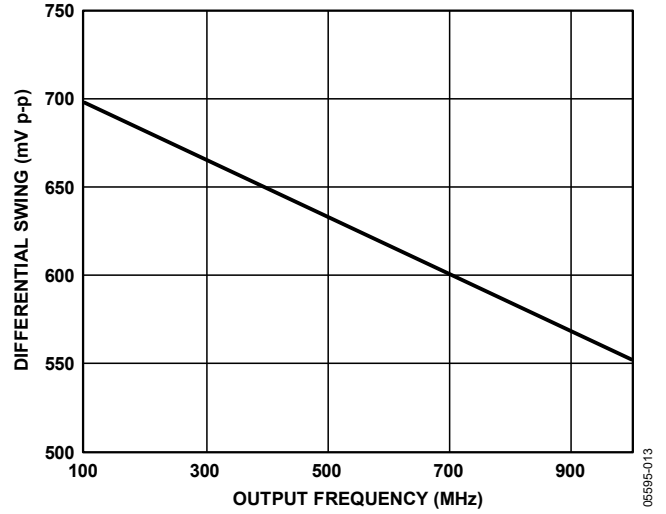

Figure 11. LVDS Differential Output Swing vs. Frequency

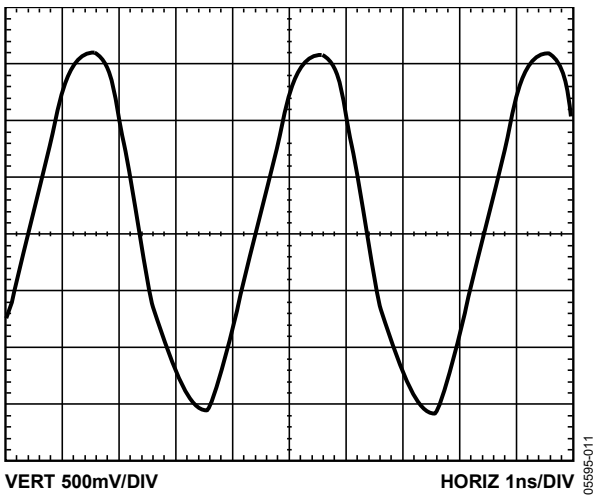

Figure 10. CMOS Single-Ended Output at 250 MHz with 10 pF Load

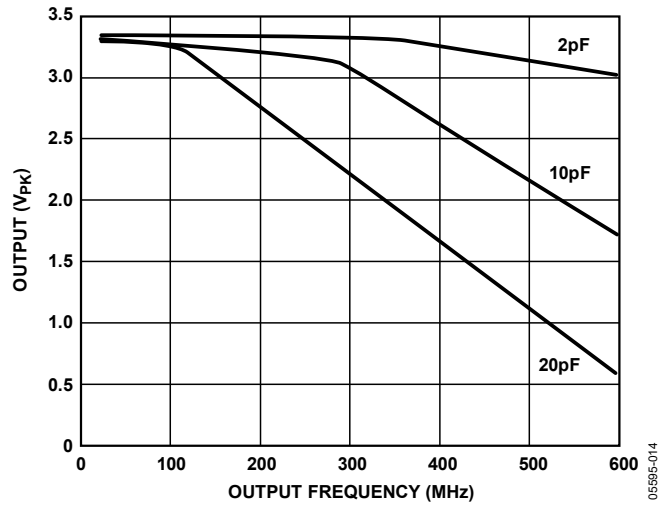

Figure 12. CMOS Single-Ended Output Swing vs. Frequency and Load

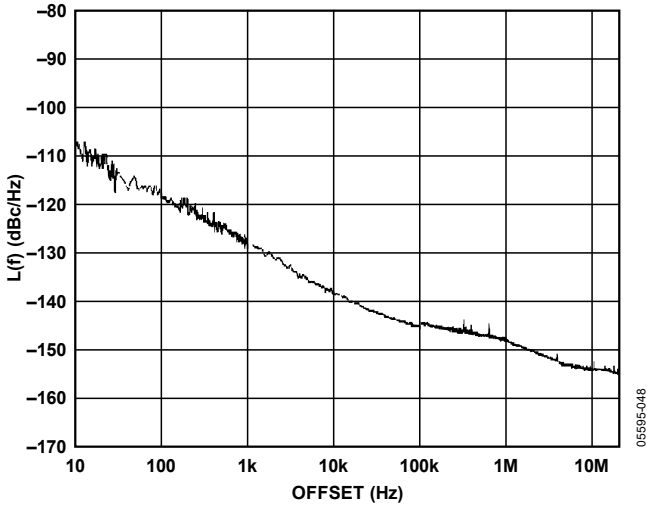

Figure 13. Additive Phase Noise—LVDS DIV 1, 245.76 MHz

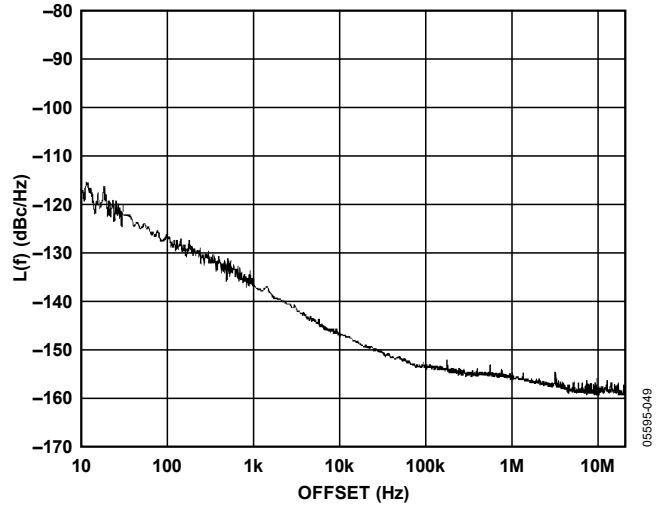

Figure 15. Additive Phase Noise—LVDS DIV2, 122.88 MHz

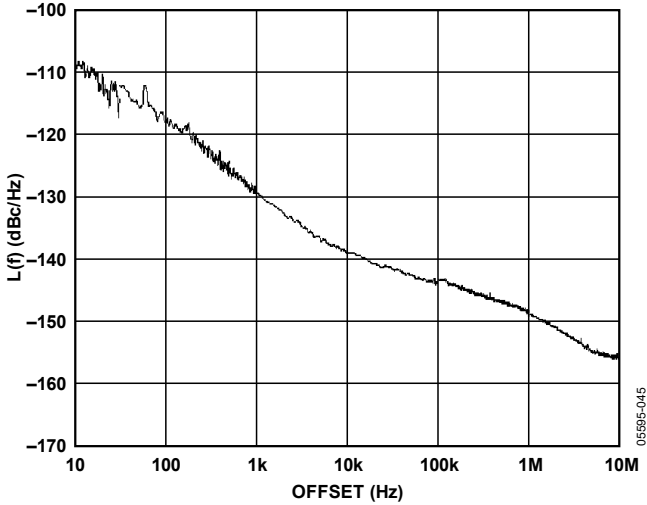

Figure 14. Additive Phase Noise—CMOS DIV 1, 245.76 MHz

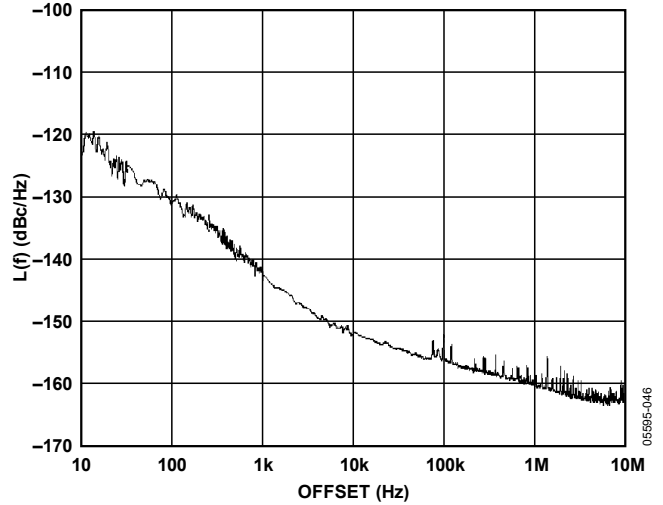

Figure 16. Additive Phase Noise—CMOS DIV4, 61.44 MHz

FUNCTIONAL DESCRIPTION

OVERALL

The AD9513 provides for the distribution of its input clock on up to three outputs. Each output can be set to either LVDS or CMOS logic levels. Each output has its own divider that can be set for a divide ratio selected from a list of integer values from 1 (bypassed) to 32.

OUT2 includes an analog delay block that can be set to add an additional delay of 1.8 ns, 6.0 ns, or 11.6 ns full scale, each with 16 levels of fine adjustment.

CLK, CLKB—DIFFERENTIAL CLOCK INPUT

The CLK and CLKB pins are differential clock input pins. This input works up to 1600 MHz. The jitter performance is degraded by a slew rate below 1 V/ns. The input level should be between approximately 150 mV p-p to no more than 2 V p-p. Anything greater can result in turning on the protection diodes on the input pins.

See Figure 17 for the CLK equivalent input circuit. This input is fully differential and self-biased. The signal should be ac-coupled using capacitors. If a single-ended input must be used, this can be accommodated by ac coupling to one side of the differential input only. The other side of the input should be bypassed to a quiet ac ground by a capacitor.

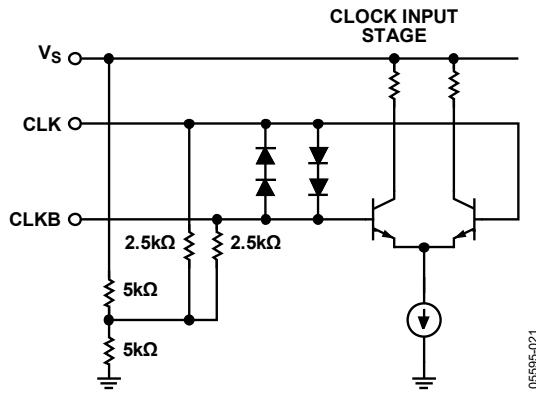

Figure 17. Clock Input Equivalent Circuit

SYNCHRONIZATION

Power-On SYNC

A power-on sync (POS) is issued when the V_s power supply is turned on to ensure that the outputs start in synchronization. The power-on sync works only if the V_s power supply transitions the region from 2.2 V to 3.1 V within 35 ms. The POS can occur up to 65 ms after V_s crosses 2.2 V. Only outputs which are not divide = 1 are synchronized.

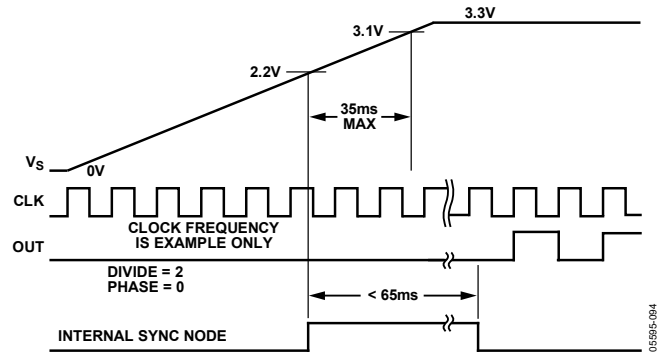

Figure 18. Power-On Sync Timing

SYNCB

If the setup configuration of the AD9513 is changed during operation, the outputs can become unsynchronized. The outputs can be resynchronized to each other at any time. Synchronization occurs when the SYNCB pin is pulled low and released. The clock outputs (except where divide = 1) are forced into a fixed state (determined by the divide and phase settings) and held there in a static condition, until the SYNCB pin is returned to high. Upon release of the SYNCB pin, after four cycles of the clock signal at CLK, all outputs continue clocking in synchronicity (except where divide = 1).

When divide = 1 for an output, that output is not affected by SYNCB.

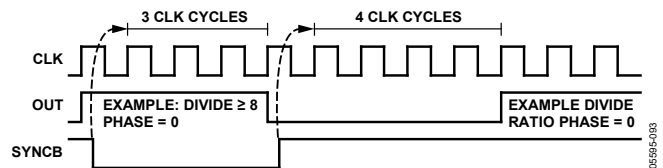

Figure 19. SYNCB Timing with Clock Present

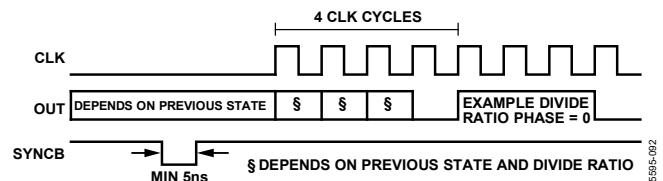

Figure 20. SYNCB Timing with No Clock Present

The outputs of the AD9513 can be synchronized by using the SYNCB pin. Synchronization aligns the phases of the clock outputs, respecting any phase offset that has been set on an output's divider.

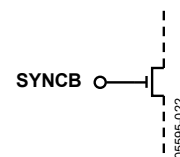

Figure 21. SYNCB Equivalent Input Circuit

Synchronization is initiated by pulling the SYNCB pin low for a minimum of 5 ns. The input clock does not have to be present at the time the command is issued. The synchronization occurs after four input clock cycles.

The synchronization applies to clock outputs

- that are not turned OFF
- where the divider is not divide = 1 (divider bypassed)

An output with its divider set to divide = 1 (divider bypassed) is always synchronized with the input clock, with a propagation delay.

The SYNCB pin must be pulled up for normal operation. Do not let the SYNCB pin float.

RSET RESISTOR

The internal bias currents of the AD9513 are set by the R_{SET} resistor. This resistor should be as close as possible to the value given as a condition in the Specifications section ($R_{SET} = 4.12 \text{ k}\Omega$). This is a standard 1% resistor value and should be readily obtainable. The bias currents set by this resistor determine the logic levels and operating conditions of the internal blocks of the AD9513. The performance figures given in the Specifications section assume that this resistor value is used for R_{SET} .

VREF

The VREF pin provides a voltage level of $\frac{2}{3} V_S$. This voltage is one of the four logic levels used by the setup pins (S_0 to S_{10}). These pins set the operation of the AD9513. The VREF pin provides sufficient drive capability to drive as many of the setup pins as necessary, up to all on a single part. The VREF pin should be used for no other purpose.

SETUP CONFIGURATION

The specific operation of the AD9513 is set by the logic levels applied to the setup pins (S_{10} to S_0). These pins use four-state logic. The logic levels used are V_S and GND, plus $\frac{1}{3} V_S$ and $\frac{2}{3} V_S$. The $\frac{1}{3} V_S$ level is provided by the internal self-biasing on each of the setup pins (S_{10} to S_0). This is the level seen by a setup pin that is left not connected (NC). The $\frac{2}{3} V_S$ level is provided by the VREF pin. All setup pins requiring the $\frac{2}{3} V_S$ level must be tied to the VREF pin.

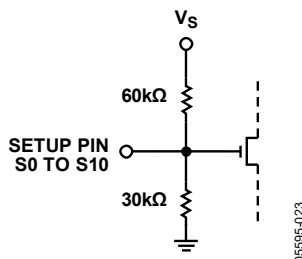

Figure 22. Setup Pin (S_0 to S_{10}) Equivalent Circuit

The AD9513 operation is determined by the combination of logic levels present at the setup pins. The setup configurations for the AD9513 are shown in Table 11 to Table 16. The four logic levels are referred to as 0, $\frac{1}{3}$, $\frac{2}{3}$, and 1. These numbers represent the fraction of the V_S voltage that defines the logic levels. See the setup pin thresholds in Table 6.

The meaning of some of the pin settings is changed by the settings of other pins. For example, S_0 determines whether S_3 , and S_4 sets OUT2 delay ($S_0 \neq 0$) or OUT2 phase ($S_0 = 0$).

S_2 indicates which outputs are in use, as shown in Table 10. This allows the same pins (S_5 and S_6 , S_7 and S_8) to determine the settings for two different outputs, depending on which outputs are in use.

Table 10. S_2 Indicates Which Outputs Are in Use

| S_2 | Outputs |
|-------|----------------|
| 0 | OUT2 Off |
| $1/3$ | All Outputs On |
| $2/3$ | OUT0 Off |
| 1 | OUT1 Off |

The fine delay values set by S_3 and S_4 (when the delay is being used, $S_0 \neq 0$) are fractions of the full-scale delay. Note that the longest setting is $15/16$ of full scale. The full-scale delay times are given in Table 3. To determine the actual delay, take the fraction corresponding to the fine delay setting and multiply by the full-scale value set by Table 3 corresponding to the S_0 value and add the LVDS or CMOS propagation delay time (see Table 3). The full-scale delay times shown in Table 11, and referred to elsewhere, are nominal time values.

The value at S_2 also determines whether S_5 and S_6 set OUT2 divide ($S_2 \neq 0$) or OUT1 phase ($S_2 = 0$). In addition, S_2 determines whether S_7 and S_8 set OUT1 divide ($S_2 \neq 1$) or OUT2 phase ($S_2 = 1$ and $S_0 \neq 0$). In addition, the value of S_2 determines whether S_9 and S_{10} set OUT0 divide ($S_2 \neq 2/3$) or OUT2 divide ($S_2 = 2/3$).

Table 11. Output Delay Full Scale

| S_0 | Delay |
|-------|---------|
| 0 | Bypass |
| $1/3$ | 1.8 ns |
| $2/3$ | 6.0 ns |
| 1 | 11.6 ns |

Table 12. Output Logic Configuration

| S1 | S2 | OUT0 | OUT1 | OUT2 |
|-----|-----|------|------|------|
| 0 | 0 | OFF | LVDS | OFF |
| 1/3 | 0 | CMOS | CMOS | OFF |
| 2/3 | 0 | LVDS | LVDS | OFF |
| 1 | 0 | LVDS | CMOS | OFF |
| 0 | 1/3 | CMOS | CMOS | CMOS |
| 1/3 | 1/3 | LVDS | LVDS | LVDS |
| 2/3 | 1/3 | LVDS | LVDS | CMOS |
| 1 | 1/3 | CMOS | CMOS | LVDS |
| 0 | 2/3 | OFF | OFF | OFF |
| 1/3 | 2/3 | OFF | OFF | LVDS |
| 2/3 | 2/3 | OFF | OFF | CMOS |
| 1 | 2/3 | OFF | CMOS | OFF |
| 0 | 1 | LVDS | OFF | CMOS |
| 1/3 | 1 | CMOS | OFF | LVDS |
| 2/3 | 1 | LVDS | OFF | LVDS |
| 1 | 1 | CMOS | OFF | CMOS |

Table 13. OUT2 Delay or Phase

| S3 | S4 | OUT2 Delay (S0 ≠ 0) | OUT2 Phase (S0 = 0) |
|-----|-----|---------------------|---------------------|
| 0 | 0 | 0 | 0 |
| 1/3 | 0 | 1/16 | 1 |
| 2/3 | 0 | 1/8 | 2 |
| 1 | 0 | 3/16 | 3 |
| 0 | 1/3 | 1/4 | 4 |
| 1/3 | 1/3 | 5/16 | 5 |
| 2/3 | 1/3 | 3/8 | 6 |
| 1 | 1/3 | 7/16 | 7 |
| 0 | 2/3 | 1/2 | 8 |
| 1/3 | 2/3 | 9/16 | 9 |
| 2/3 | 2/3 | 5/8 | 10 |
| 1 | 2/3 | 11/16 | 11 |
| 0 | 1 | 3/4 | 12 |
| 1/3 | 1 | 13/16 | 13 |
| 2/3 | 1 | 7/8 | 14 |
| 1 | 1 | 15/16 | 15 |

Table 14. OUT2 Divide or OUT1 Phase

| S5 | S6 | OUT2 Divide (Duty Cycle ¹) (S2 ≠ 0 or 2/3) | OUT1 Phase (S2 = 0) |
|-----|-----|--|---------------------|
| 0 | 0 | 1 | 0 |
| 1/3 | 0 | 2 (50%) | 1 |
| 2/3 | 0 | 3 (33%) | 2 |
| 1 | 0 | 4 (50%) | 3 |
| 0 | 1/3 | 5 (40%) | 4 |
| 1/3 | 1/3 | 6 (50%) | 5 |
| 2/3 | 1/3 | 8 (50%) | 6 |
| 1 | 1/3 | 9 (44%) | 7 |
| 0 | 2/3 | 10 (50%) | 8 |
| 1/3 | 2/3 | 12 (50%) | 9 |
| 2/3 | 2/3 | 15 (47%) | 10 |
| 1 | 2/3 | 16 (50%) | 11 |
| 0 | 1 | 18 (50%) | 12 |
| 1/3 | 1 | 24 (50%) | 13 |
| 2/3 | 1 | 30 (50%) | 14 |
| 1 | 1 | 32 (50%) | 15 |

¹ Duty cycle is the clock signal high time divided by the total period.

Table 15. OUT1 Divide or OUT2 Phase

| S7 | S8 | OUT1 Divide (Duty Cycle ¹) (S2 ≠ 1) | OUT2 Phase (S2 = 1 and S0 ≠ 0) |
|-----|-----|---|--------------------------------|
| 0 | 0 | 1 | 0 |
| 1/3 | 0 | 2 (50%) | 1 |
| 2/3 | 0 | 3 (33%) | 2 |
| 1 | 0 | 4 (50%) | 3 |
| 0 | 1/3 | 5 (40%) | 4 |
| 1/3 | 1/3 | 6 (50%) | 5 |
| 2/3 | 1/3 | 8 (50%) | 6 |
| 1 | 1/3 | 9 (44%) | 7 |
| 0 | 2/3 | 10 (50%) | 8 |
| 1/3 | 2/3 | 12 (50%) | 9 |
| 2/3 | 2/3 | 15 (47%) | 10 |
| 1 | 2/3 | 16 (50%) | 11 |
| 0 | 1 | 18 (50%) | 12 |
| 1/3 | 1 | 24 (50%) | 13 |
| 2/3 | 1 | 30 (50%) | 14 |
| 1 | 1 | 32 (50%) | 15 |

¹ Duty cycle is the clock signal high time divided by the total period.

Table 16. OUT0 Divide or OUT2 Divide

| S9 | S10 | OUT0 Divide (Duty Cycle ¹) S2 ≠ 2/3 | OUT2 Divide (Duty Cycle ¹) S2 = 2/3 |
|-----|-----|--|--|
| 0 | 0 | 1 | 7 (43%) |
| 1/3 | 0 | 2 (50%) | 11 (45%) |
| 2/3 | 0 | 3 (33%) | 13 (46%) |
| 1 | 0 | 4 (50%) | 14 (50%) |
| 0 | 1/3 | 5 (40%) | 17 (47%) |
| 1/3 | 1/3 | 6 (50%) | 19 (47%) |
| 2/3 | 1/3 | 8 (50%) | 20 (50%) |
| 1 | 1/3 | 9 (44%) | 21 (48%) |
| 0 | 2/3 | 10 (50%) | 22 (50%) |
| 1/3 | 2/3 | 12 (50%) | 23 (48%) |
| 2/3 | 2/3 | 15 (47%) | 25 (48%) |
| 1 | 2/3 | 16 (50%) | 26 (50%) |
| 0 | 1 | 18 (50%) | 27 (48%) |
| 1/3 | 1 | 24 (50%) | 28 (50%) |
| 2/3 | 1 | 30 (50%) | 29 (48%) |
| 1 | 1 | 32 (50%) | 31 (48%) |

¹Duty cycle is the clock signal high time divided by the total period.

DIVIDER PHASE OFFSET

The phase offset of OUT1 and OUT2 can be selected (see Table 13 to Table 15). This allows the relative phase of the outputs to be set.

After a SYNC operation (see the Synchronization section), the phase offset word of each divider determines the number of input clock (CLK) cycles to wait before initiating a clock output edge. By giving each divider a different phase offset, output-to-output delays can be set in increments of the fast clock period, t_{CLK} .

Figure 23 shows four cases, each with the divider set to divide = 4. By incrementing the phase offset from 0 to 3, the output is offset from the initial edge by a multiple of t_{CLK} .

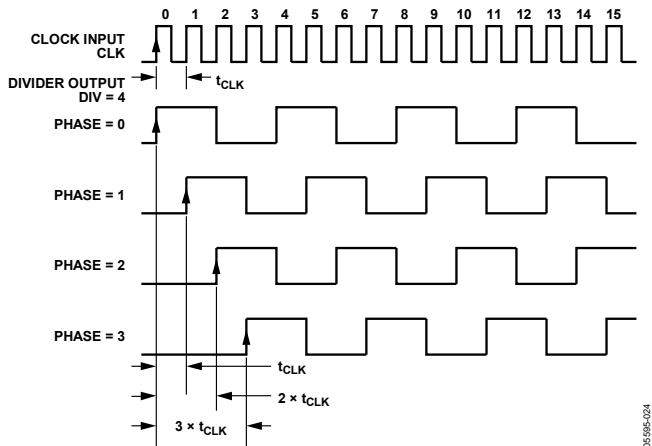

Figure 23. Phase Offset—Divider Set for Divide = 4, Phase Set from 0 to 2

For example:

$$CLK = 491.52 \text{ MHz}$$

$$t_{CLK} = 1/491.52 = 2.0345 \text{ ns}$$

For Divide = 4:

$$\text{Phase Offset } 0 = 0 \text{ ns}$$

$$\text{Phase Offset } 1 = 2.0345 \text{ ns}$$

$$\text{Phase Offset } 2 = 4.069 \text{ ns}$$

$$\text{Phase Offset } 3 = 6.104 \text{ ns}$$

The outputs can also be described as:

$$\text{Phase Offset } 0 = 0^\circ$$

$$\text{Phase Offset } 1 = 90^\circ$$

$$\text{Phase Offset } 2 = 180^\circ$$

$$\text{Phase Offset } 3 = 270^\circ$$

Setting the phase offset to Phase = 4 results in the same relative phase as Phase = 0° or 360°.

The resolution of the phase offset is set by the fast clock period (t_{CLK}) at CLK. The maximum unique phase offset is less than the divide ratio, up to a phase offset of 15.

Phase offsets can be related to degrees by calculating the phase step for a particular divide ratio:

$$\text{Phase Step} = 360^\circ / \text{Divide Ratio}$$

Using some of the same examples:

$$\text{Divide} = 4$$

$$\text{Phase Step} = 360^\circ / 4 = 90^\circ$$

Unique Phase Offsets in Degrees Are Phase = 0°, 90°, 180°, 270°

$$\text{Divide} = 9$$

$$\text{Phase Step} = 360^\circ / 9 = 40^\circ$$

Unique Phase Offsets in Degrees Are Phase = 0°, 40°, 80°, 120°, 160°, 200°, 240°, 280°, 320°

DELAY BLOCK

OUT2 includes an analog delay element that gives variable time delays (ΔT) in the clock signal passing through that output.

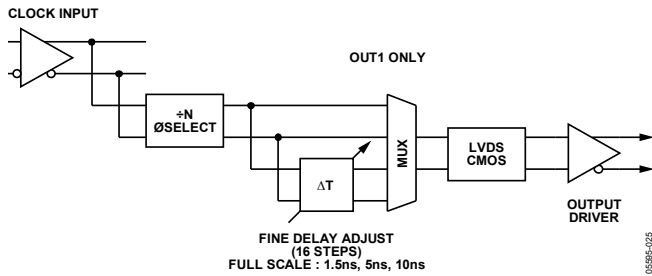

Figure 24. Analog Delay Block

The amount of delay that can be used is determined by the output frequency. The amount of delay is limited to less than one-half cycle of the clock period. For example, for a 10 MHz clock, the delay can extend to the full 11.6 ns maximum. However, for a 100 MHz clock, the maximum delay is less than 5 ns (or half of the period).

The AD9513 allows for the selection of three full-scale delays, 1.8 ns, 6.0 ns, and 11.6 ns, set by delay full-scale (see Table 11). Each of these full-scale delays can be scaled by 16 fine adjustment values, which are set by the delay word (see Table 13).

The delay block adds some jitter to the output. This means that the delay function should be used primarily for clocking digital chips, such as FPGA, ASIC, DUC, and DDC, rather than for supplying a sample clock for data converters. The jitter is higher for longer full scales because the delay block uses a ramp and trip points to create the variable delay. A longer ramp means more noise has a chance of being introduced.

When the delay block is OFF (bypassed), it is also powered down.

OUTPUTS

Each of the three AD9513 outputs can be selected either as LVDS differential outputs or as pairs of CMOS single-ended outputs. If selected as CMOS, the OUT is a noninverted, single-ended output, and OUTB is an inverted, single-ended output.

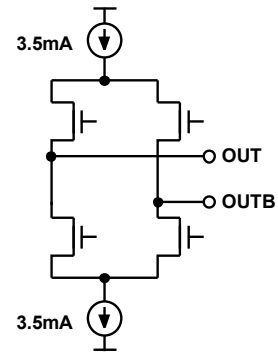

Figure 25. LVDS Output Simplified Equivalent Circuit

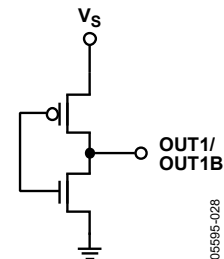

Figure 26. CMOS Equivalent Output Circuit

POWER SUPPLY

The AD9513 requires a $3.3\text{ V} \pm 5\%$ power supply for V_s . The tables in the Specifications section give the performance expected from the AD9513 with the power supply voltage within this range. In no case should the absolute maximum range of -0.3 V to $+3.6\text{ V}$, with respect to GND, be exceeded on Pin V_S .

Good engineering practice should be followed in the layout of power supply traces and the ground plane of the PCB. The power supply should be bypassed on the PCB with adequate capacitance ($>10\text{ }\mu\text{F}$). The AD9513 should be bypassed with adequate capacitors ($0.1\text{ }\mu\text{F}$) at all power pins as close as possible to the part. The layout of the AD9513 evaluation board (AD9513/PCB) is a good example.

Exposed Metal Paddle

The exposed metal paddle on the AD9513 package is an electrical connection, as well as a thermal enhancement. For the device to function properly, the paddle must be properly attached to ground (GND).

The exposed paddle of the AD9513 package must be soldered down. The AD9513 must dissipate heat through its exposed paddle. The PCB acts as a heat sink for the AD9513. The PCB attachment must provide a good thermal path to a larger heat dissipation area, such as a ground plane on the PCB. This requires a grid of vias from the top layer down to the ground plane (see Figure 27). The AD9513 evaluation board (AD9513/PCB) provides a good example of how the part should be attached to the PCB.

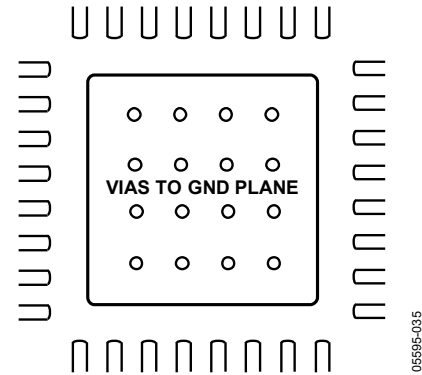

Figure 27. PCB Land for Attaching Exposed Paddle

POWER MANAGEMENT

In some cases, the AD9513 can be configured to use less power by turning off functions that are not being used.

The power-saving options include the following:

- A divider is powered down when set to divide = 1 (bypassed).
- Adjustable delay block on OUT2 is powered down when in off mode ($S_0 = 0$).
- An unneeded output can be powered down (see Table 12). This also powers down the divider for that output.

APPLICATIONS INFORMATION

USING THE AD9513 OUTPUTS FOR ADC CLOCK APPLICATIONS

Any high speed, analog-to-digital converter (ADC) is extremely sensitive to the quality of the sampling clock provided by the user. An ADC can be thought of as a sampling mixer; any noise, distortion, or timing jitter on the clock is combined with the desired signal at the A/D output. Clock integrity requirements scale with the analog input frequency and resolution, with higher analog input frequency applications at ≥ 14 -bit resolution being the most stringent. The theoretical SNR of an ADC is limited by the ADC resolution and the jitter on the sampling clock. Considering an ideal ADC of infinite resolution where the step size and quantization error can be ignored, the available SNR can be expressed approximately by

$$SNR = 20 \times \log \left[\frac{1}{2\pi f t_j} \right]$$

where f is the highest analog frequency being digitized.

t_j is the rms jitter on the sampling clock.

Figure 28 shows the required sampling clock jitter as a function of the analog frequency and effective number of bits (ENOB).

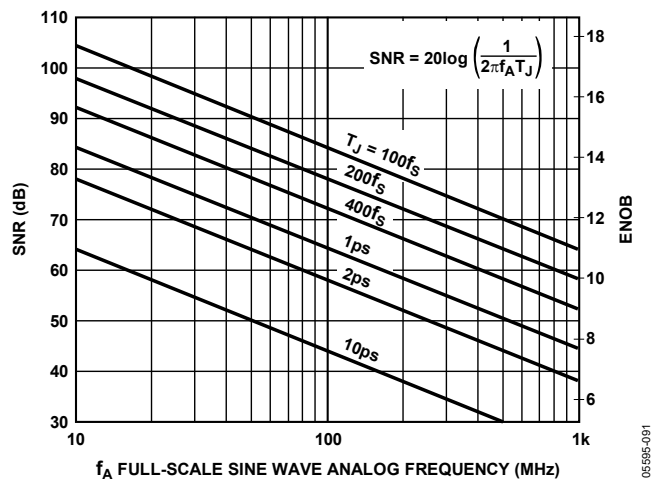

Figure 28. ENOB and SNR vs. Analog Input Frequency

See Application Note AN-756 and Application Note AN-501 at www.analog.com.

Many high performance ADCs feature differential clock inputs to simplify the task of providing the required low jitter clock on a noisy PCB. (Distributing a single-ended clock on a noisy PCB can result in coupled noise on the sample clock. Differential distribution has inherent common-mode rejection that can provide superior clock performance in a noisy environment.) The AD9513 features LVDS outputs that provide differential clock outputs, which enable clock solutions that maximize converter SNR performance. The input requirements of the ADC (differential or single-ended, logic level, termination)

should be considered when selecting the best clocking/converter solution.

LVDS CLOCK DISTRIBUTION

The AD9513 provides three clock outputs that are selectable as either CMOS or LVDS levels. LVDS uses a current mode output stage. The current is 3.5 mA, which yields 350 mV output swing across a 100 Ω resistor. The LVDS outputs meet or exceed all ANSI/TIA/EIA-644 specifications.

A recommended termination circuit for the LVDS outputs is shown in Figure 29.

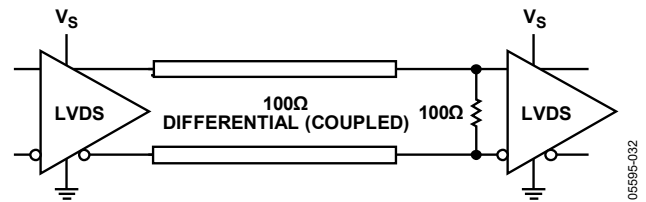

Figure 29. LVDS Output Termination

See Application Note AN-586 at www.analog.com for more information on LVDS.

CMOS CLOCK DISTRIBUTION

The AD9513 provides three outputs that are selectable as either CMOS or LVDS levels. When selected as CMOS, an output provides for driving devices requiring CMOS level logic at their clock inputs.

Whenever single-ended CMOS clocking is used, some of the following general guidelines should be used.

Point-to-point nets should be designed such that a driver has one receiver only on the net, if possible. This allows for simple termination schemes and minimizes ringing due to possible mismatched impedances on the net. Series termination at the source is generally required to provide transmission line matching and/or to reduce current transients at the driver. The value of the resistor is dependent on the board design and timing requirements (typically 10 Ω to 100 Ω is used). CMOS outputs are also limited in terms of the capacitive load or trace length that they can drive. Typically, trace lengths less than 3 inches are recommended to preserve signal rise/fall times and preserve signal integrity.

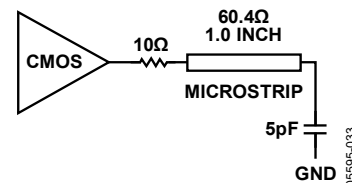

Figure 30. Series Termination of CMOS Output

Termination at the far end of the PCB trace is a second option. The CMOS outputs of the AD9513 do not supply enough current to provide a full voltage swing with a low impedance resistive, far-end termination, as shown in Figure 31.

The far-end termination network should match the PCB trace impedance and provide the desired switching point. The reduced signal swing may still meet receiver input requirements in some applications. This can be useful when driving long trace lengths on less critical nets.

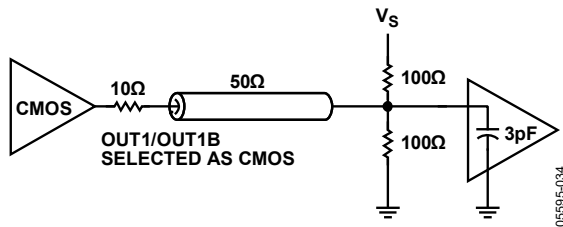

Figure 31. CMOS Output with Far-End Termination

Because of the limitations of single-ended CMOS clocking, consider using differential outputs when driving high speed signals over long traces. The AD9513 offers LVDS outputs that are better suited for driving long traces where the inherent noise immunity of differential signaling provides superior performance for clocking converters.

SETUP PINS (S0 TO S10)

The setup pins that require a logic level of $\frac{1}{3} V_s$ (internal self-bias) should be tied together and bypassed to ground via a capacitor.

The setup pins that require a logic level of $\frac{2}{3} V_s$ should be tied together, along with the VREF pin, and bypassed to ground via a capacitor.

POWER AND GROUNDING CONSIDERATIONS AND POWER SUPPLY REJECTION

Many applications seek high speed and performance under less than ideal operating conditions. In these application circuits, the implementation and construction of the PCB is as important as the circuit design. Proper RF techniques must be used for device selection, placement, and routing, as well as power supply bypassing and grounding to ensure optimum performance.

PHASE NOISE AND JITTER MEASUREMENT SETUPS

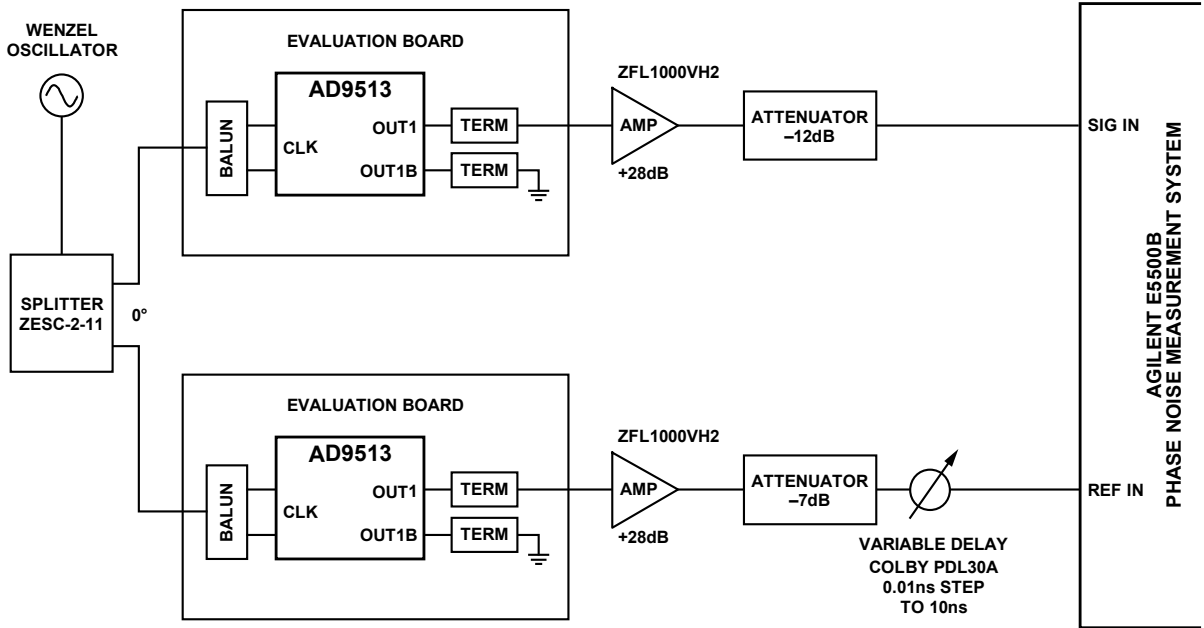

Figure 32. Additive Phase Noise Measurement Configuration

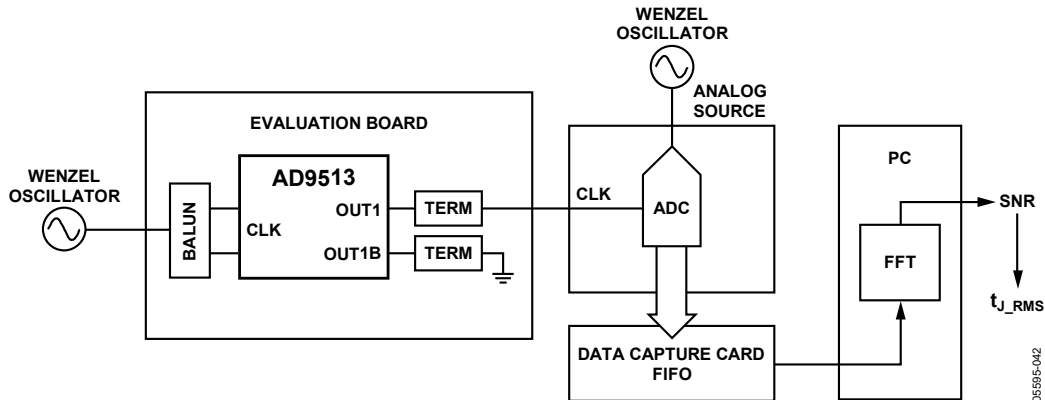

Figure 33. Jitter Determination by Measuring SNR of ADC

$$t_{J_RMS} = \sqrt{\frac{\left[\frac{V_{A_RMS}}{10^{20} \cdot SNR} \right]^2 - (SND \times \sqrt{BW})^2 - (\theta_{QUANTIZATION}^2 + \theta_{THERMAL}^2 + \theta_{DNL}^2)}{[2\pi \times f_A \times V_{A_PK}]^2}}$$

where:

t_{J_RMS} is the rms time jitter.

SNR is the signal-to-noise ratio.

SND is the source noise density in nV/ \sqrt{Hz} .

BW is the SND filter bandwidth.

V_A is the analog source voltage.

f_A is the analog frequency.

The θ terms are the quantization, thermal, and DNL errors.

OUTLINE DIMENSIONS

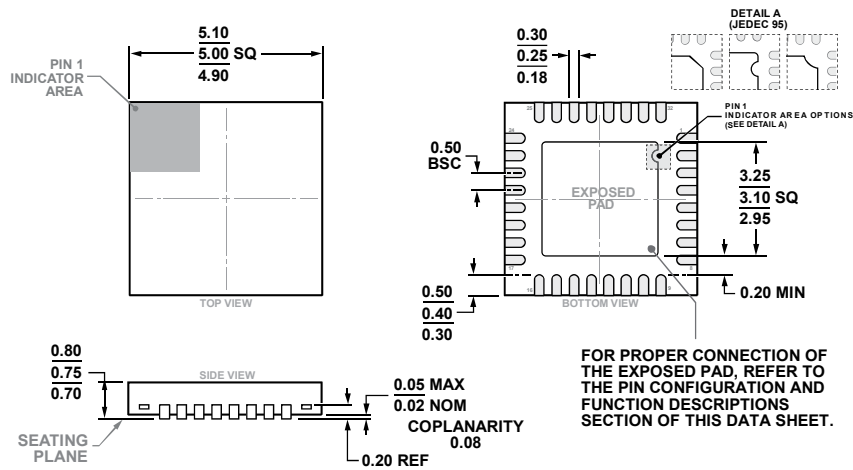

COMPLIANT TO JEDEC STANDARDS MO-220-WHHD

Figure 34. 32-Lead Lead Frame Chip Scale Package [LFCSP]
5 mm × 5 mm Body and 0.75 mm Package Height
(CP-32-7)
Dimensions shown in millimeters

ORDERING GUIDE

| Model ¹ | Temperature Range | Package Description | Package Option |
|--------------------|-------------------|---------------------|----------------|
| AD9513BCPZ | -40°C to +85°C | 32-Lead LFCSP | CP-32-7 |
| AD9513BCPZ-REEL7 | -40°C to +85°C | 32-Lead LFCSP | CP-32-7 |
| AD9513/PCBZ | | Evaluation Board | |



¹ Z = RoHS Compliant Part.

NOTES

NOTES

Looking for pricing, stock, or lifecycle information?

Click below to explore more details on WIN SOURCE:

-  View [AD9513BCPZ-REEL7](#) on WIN SOURCE
-  [Analog Devices Inc.](#) Information

Optimize Your Supply Chain with WIN SOURCE Solutions

-  Global Sourcing Solution
-  Obsolete Management
-  Cost Control Management
-  Shortage Management
-  Alternative Solution
-  Excess Inventory Management