



**THE DATASHEET OF
AD9510BCPZ**



FEATURES

- Low phase noise phase-locked loop core
 - Reference input frequencies to 250 MHz
 - Programmable dual modulus prescaler
 - Programmable charge pump (CP) current
 - Separate CP supply (VCP_s) extends tuning range
- Two 1.6 GHz, differential clock inputs
- 8 programmable dividers, 1 to 32, all integers
- Phase select for output-to-output coarse delay adjust
- 4 independent 1.2 GHz LVPECL outputs
 - Additive output jitter of 225 fs rms
- 4 independent 800 MHz low voltage differential signaling (LVDS) or 250 MHz complementary metal oxide conductor (CMOS) clock outputs
 - Additive output jitter of 275 fs rms
- Fine delay adjust on 2 LVDS/CMOS outputs
- Serial control port
- Space-saving 64-lead LFCSP

APPLICATIONS

- Low jitter, low phase noise clock distribution
- Clocking high speed ADCs, DACs, DDSs, DDCs, DUCs, and mixed-signal front ends (MxFEs)
- High performance wireless transceivers
- High performance instrumentation
- Broadband infrastructure

GENERAL DESCRIPTION

The **AD9510** provides a multi-output clock distribution function along with an on-chip phase-locked loop (PLL) core. The design emphasizes low jitter and phase noise to maximize data converter performance. Other applications with demanding phase noise and jitter requirements also benefit from this device.

The PLL section consists of a programmable reference divider (R); a low noise, phase frequency detector (PFD); a precision charge pump (CP); and a programmable feedback divider (N). By connecting an external voltage-controlled crystal oscillator (VCXO) or voltage-controlled oscillator (VCO) to the CLK2 and CLK2B pins, frequencies of up to 1.6 GHz can be synchronized to the input reference.

There are eight independent clock outputs. Four outputs are low voltage positive emitter-coupled logic (LVPECL) at 1.2 GHz, and four are selectable as either LVDS (800 MHz) or CMOS (250 MHz) levels.

FUNCTIONAL BLOCK DIAGRAM

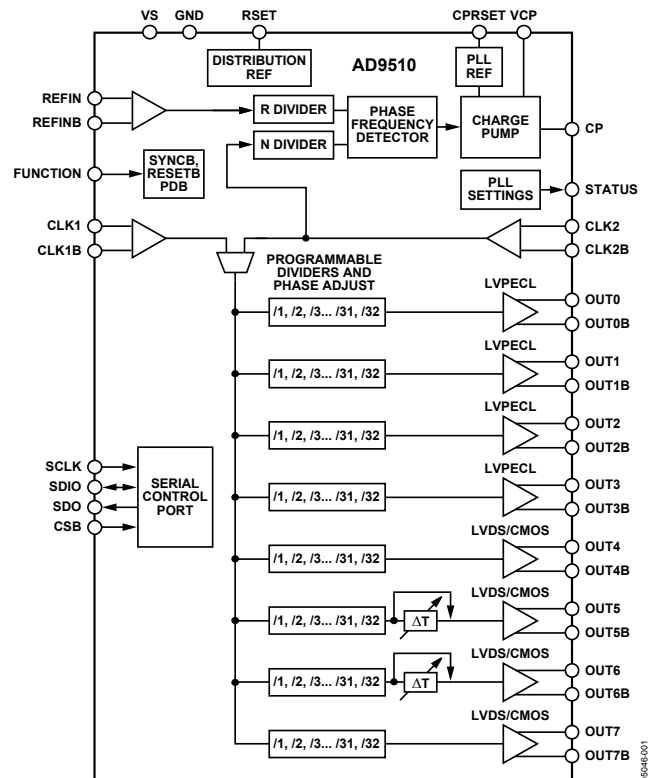

Figure 1.

Each output has a programmable divider that can be bypassed or set to divide by any integer up to 32. The phase of one clock output relative to another clock output can be varied by means of a divider phase select function that serves as a coarse timing adjustment. Two of the LVDS/CMOS outputs feature programmable delay elements with full-scale ranges up to 8 ns of delay. This fine tuning delay block has 5-bit resolution, giving 25 possible delays from which to choose for each full-scale setting (Register 0x36 and Register 0x3A = 00000b to 11000b).

The **AD9510** is ideally suited for data converter clocking applications where maximum converter performance is achieved by encode signals with subpicosecond jitter.

The **AD9510** is available in a 64-lead LFCSP and can be operated from a single 3.3 V supply. An external VCO, which requires an extended voltage range, can be accommodated by connecting the charge pump supply (VCP) to 5.5 V. The temperature range is -40°C to $+85^{\circ}\text{C}$.

TABLE OF CONTENTS

Features	1	Overall	28
Applications.....	1	PLL Section	28
Functional Block Diagram	1	FUNCTION Pin	32
General Description	1	Distribution Section.....	32
Revision History	2	CLK1 and CLK2 Clock Inputs.....	32
Specifications.....	4	Dividers.....	32
PLL Characteristics	4	Delay Block	37
Clock Inputs	5	Outputs	37
Clock Outputs	6	Power-Down Modes	38
Timing Characteristics	6	Reset Modes	38
Clock Output Phase Noise	8	Single-Chip Synchronization.....	39
Clock Output Additive Time Jitter.....	11	Multichip Synchronization	39
PLL and Distribution Phase Noise and Spurious.....	13	Serial Control Port	40
Serial Control Port	13	Serial Control Port Pin Descriptions.....	40
FUNCTION Pin	14	General Operation of Serial Control Port.....	40
STATUS Pin	14	The Instruction Word (16 Bits).....	41
Power.....	15	MSB/LSB First Transfers	41
Timing Diagrams.....	16	Register Map and Description	44
Absolute Maximum Ratings.....	17	Summary Table	44
Thermal Characteristics	17	Register Map Description	46
ESD Caution.....	17	Power Supply.....	53
Pin Configuration and Function Descriptions.....	18	Power Management.....	53
Typical Performance Characteristics	20	Applications Information	54
Terminology	24	Using the AD9510 Outputs for ADC Clock Applications....	54
Typical Modes of Operation.....	25	CMOS Clock Distribution	54
PLL with External VCXO/VCO Followed by Clock		LVPECL Clock Distribution	55
Distribution	25	LVDS Clock Distribution	55
Clock Distribution Only.....	25	Power and Grounding Considerations and Power Supply	
PLL with External VCO and Band-Pass Filter Followed by		Rejection.....	55
Clock Distribution.....	26	Outline Dimensions	56
Functional Description	28	Ordering Guide	56

REVISION HISTORY

9/2016—Rev. B to Rev. C

Changes to STATUS Pin Section	30
Changes to Ordering Guide	56

9/2013—Rev. A to Rev. B

Changes to General Description Section	1
Changes to Table 4.....	6
Changes to Table 6.....	11
Added Table 13; Renumbered Sequentially	17
Changes to Figure 6.....	18

Added EPAD Row, Table 14.....	19
Changes to Figure 21.....	22
Changes to Delay Block Section, Figure 40, and Calculating the	
Delay Section.....	37
Changes to Address 0x36[5:1] and Address 0x3A[5:1],	
Table 24	44
Changes to Address 0x36 and Address 0x3A, Table 25.....	49
Updated Outline Dimensions	56
Changes to Ordering Guide	56

5/2005—Rev. 0 to Rev. A

Changes to Features	1
Changes to Table 1 and Table 2	5
Changes to Table 4	8
Changes to Table 5	9
Changes to Table 6	14
Changes to Table 8 and Table 9	15
Changes to Table 11	16
Changes to Table 13	20
Changes to Figure 7 and Figure 10	22
Changes to Figure 19 to Figure 23	24
Changes to Figure 30 and Figure 31	26
Changes to Figure 32	27
Changes to Figure 33	28
Changes to VCO/VCXO Clock Input—CLK2 Section	29
Changes to A and B Counters Section	30
Changes to PLL Digital Lock Detect Section	31
Changes to PLL Analog Lock Detect Section	32
Changes to Loss of Reference Section	32
Changes to FUNCTION Pin Section	33
Changes to RESETB: 58h<6:5> = 00b (Default) Section	33
Changes to SYNCB: 58h<6:5> = 01b Section	33
Changes to CLK1 and CLK2 Clock Inputs Section	33

Changes to Calculating the Delay Section	38
Changes to Soft Reset via the Serial Port Section	41
Changes to Multichip Synchronization Section	41
Changes to Serial Control Port Section	42
Changes to Serial Control Port Pin Descriptions Section	42
Changes to General Operation of Serial Control Port Section	42
Added Framing a Communication Cycle with CSB Section	42
Added Communication Cycle—Instruction Plus Data Section	42
Changes to Write Section	42
Changes to Read Section	42
Changes to The Instruction Word (16 Bits) Section	43
Changes to Table 20	43
Changes to MSB/LSB First Transfers Section	43
Changes to Table 21	44
Added Figure 52; Renumbered Sequentially	45
Changes to Table 23	46
Changes to Table 24	49
Changes to Using the AD9510 Outputs for ADC Clock Applications	57

4/2005—Revision 0: Initial Version

SPECIFICATIONS

Typical (typ) is given for $V_S = 3.3 \text{ V} \pm 5\%$, $V_S \leq V_{CP_S} \leq 5.5 \text{ V}$, $T_A = 25^\circ\text{C}$, $R_{SET} = 4.12 \text{ k}\Omega$, $CPR_{SET} = 5.1 \text{ k}\Omega$, unless otherwise noted. Minimum (min) and maximum (max) values are given over full V_S and T_A (-40°C to $+85^\circ\text{C}$) variation.

PLL CHARACTERISTICS

Table 1.

Parameter	Min	Typ	Max	Unit	Test Conditions/Comments
REFERENCE INPUTS (REFIN)					
Input Frequency	0		250	MHz	
Input Sensitivity		150		mV p-p	
Self-Bias Voltage, REFIN	1.45	1.60	1.75	V	Self-bias voltage of REFIN ¹
Self-Bias Voltage, REFINB	1.40	1.50	1.60	V	Self-bias voltage of REFINB ¹
Input Resistance, REFIN	4.0	4.9	5.8	k Ω	Self-biased ¹
Input Resistance, REFINB	4.5	5.4	6.3	k Ω	Self-biased ¹
Input Capacitance		2		pF	
PHASE FREQUENCY DETECTOR (PFD)					
PFD Input Frequency			100	MHz	Antibacklash pulse width, Register 0x0D[1:0] = 00b
PFD Input Frequency			100	MHz	Antibacklash pulse width, Register 0x0D[1:0] = 01b
PFD Input Frequency			45	MHz	Antibacklash pulse width, Register 0x0D[1:0] = 10b
Antibacklash Pulse Width		1.3		ns	Register 0x0D[1:0] = 00b (this is the default setting)
Antibacklash Pulse Width		2.9		ns	Register 0x0D[1:0] = 01b
Antibacklash Pulse Width		6.0		ns	Register 0x0D[1:0] = 10b
CHARGE PUMP (CP)					
I_{CP} Sink/Source					Programmable
High Value		4.8		mA	With $CPR_{SET} = 5.1 \text{ k}\Omega$
Low Value		0.60		mA	
Absolute Accuracy		2.5		%	$V_{CP} = V_{CP_S}/2$
CPR_{SET} Range		2.7/10		k Ω	
I_{CP} Three-State Leakage		1		nA	
Sink-and-Source Current Matching		2		%	$0.5 < V_{CP} < V_{CP_S} - 0.5 \text{ V}$
I_{CP} vs. V_{CP}		1.5		%	$0.5 < V_{CP} < V_{CP_S} - 0.5 \text{ V}$
I_{CP} vs. Temperature		2		%	$V_{CP} = V_{CP_S}/2 \text{ V}$
RF CHARACTERISTICS (CLK2) ²					
Input Frequency			1.6	GHz	Frequencies > 1200 MHz (LVPECL) or 800 MHz (LVDS) require a minimum divide-by-2 (see the Distribution Section)
Input Sensitivity		150		mV p-p	
Input Common-Mode Voltage, V_{CM}	1.5	1.6	1.7	V	Self-biased, enables ac coupling
Input Common-Mode Range, V_{CMR}	1.3		1.8	V	With 200 mV p-p signal applied
Input Sensitivity, Single-Ended		150		mV p-p	CLK2 ac-coupled, CLK2B capacitively bypassed to RF ground
Input Resistance	4.0	4.8	5.6	k Ω	Self-biased
Input Capacitance		2		pF	
CLK2 VS. REFIN DELAY		500		ps	Difference at PFD
PRESCALER (PART OF N DIVIDER)					
Prescaler Input Frequency					See the VCO/VCXO Feedback Divider—N (P, A, B) section
P = 2 DM (2/3)			600	MHz	
P = 4 DM (4/5)			1000	MHz	
P = 8 DM (8/9)			1600	MHz	
P = 16 DM (16/17)			1600	MHz	
P = 32 DM (32/33)			1600	MHz	
CLK2 Input Frequency for PLL			300	MHz	A, B counter input frequency

Parameter	Min	Typ	Max	Unit	Test Conditions/Comments
NOISE CHARACTERISTICS					
In-Band Noise of the Charge Pump/ Phase Frequency Detector (In-Band Means Within the LBW of the PLL)					Synthesizer phase noise floor estimated by measuring the in-band phase noise at the output of the VCO and subtracting $20\log N$ (where N is the N divider value)
At 50 kHz PFD Frequency		-172		dBc/Hz	
At 2 MHz PFD Frequency		-156		dBc/Hz	
At 10 MHz PFD Frequency		-149		dBc/Hz	
At 50 MHz PFD Frequency		-142		dBc/Hz	
PLL Figure of Merit		-218 + $10 \times \log$ (f_{PFD})		dBc/Hz	Approximation of the PFD/CP phase noise floor (in the flat region) inside the PLL loop bandwidth; when running closed loop this phase noise is gained up by $20 \times \log(N)^3$
PLL DIGITAL LOCK DETECT WINDOW⁴					
Required to Lock (Coincidence of Edges)					Signal available at STATUS pin when selected by Register 0x08[5:2]
Low Range (ABP 1.3 ns, 2.9 ns)		3.5		ns	Selected by Register 0x0D Bit[5] = 1b.
High Range (ABP 1.3 ns, 2.9 ns)		7.5		ns	Bit[5] = 0b.
High Range (ABP 6 ns)		3.5		ns	Bit[5] = 0b.
To Unlock After Lock (Hysteresis) ⁴					Selected by Register 0x0D
Low Range (ABP 1.3 ns, 2.9 ns)		7		ns	Bit[5] = 1b.
High Range (ABP 1.3 ns, 2.9 ns)		15		ns	Bit[5] = 0b.
High Range (ABP 6 ns)		11		ns	Bit[5] = 0b.

¹ REFIN and REFINB self-bias points are offset slightly to avoid chatter on an open input condition.

² CLK2 is electrically identical to CLK1; the distribution-only input can be used as differential or single-ended input (see the Clock Inputs section).

³ Example: $-218 + 10 \times \log(f_{\text{PFD}}) + 20 \times \log(N)$ gives the values for the in-band noise at the VCO output.

⁴ For reliable operation of the digital lock detect, the period of the PFD frequency must be greater than the unlock-after-lock time.

CLOCK INPUTS

Table 2.

Parameter	Symbol	Min	Typ	Max	Unit	Test Conditions/Comments
CLOCK INPUTS (CLK1, CLK2)¹						
Input Frequency		0		1.6	GHz	
Input Sensitivity			150 ²		mV p-p	Jitter performance can be improved with higher slew rates (greater swing)
Input Level				2 ³	V p-p	Larger swings turn on the protection diodes and can degrade jitter performance
Input Common-Mode Voltage	V_{CM}	1.5	1.6	1.7	V	Self-biased; enables ac coupling
Input Common-Mode Range	V_{CMR}	1.3		1.8	V	With 200 mV p-p signal applied; dc-coupled
Input Sensitivity, Single-Ended			150		mV p-p	CLK2 ac-coupled, CLK2B ac-bypassed to RF ground
Input Resistance		4.0	4.8	5.6	k Ω	Self-biased
Input Capacitance			2		pF	

¹ CLK1 and CLK2 are electrically identical; each can be used as either a differential or a single-ended input.

² With a 50 Ω termination, this is -12.5 dBm.

³ With a 50 Ω termination, this is +10 dBm.

CLOCK OUTPUTS

Table 3.

Parameter	Symbol	Min	Typ	Max	Unit	Test Conditions/Comments
LVPECL CLOCK OUTPUTS OUT0, OUT1, OUT2, OUT3; Differential						Termination = 50 Ω to $V_S - 2V$ Output level Register 0x3C, Register 0x3D, Register 0x3E, Register 0x3F[3:2] = 10b See Figure 21
Output Frequency				1200	MHz	
Output High Voltage	V_{OH}	$V_S - 1.22$	$V_S - 0.98$	$V_S - 0.93$	V	
Output Low Voltage	V_{OL}	$V_S - 2.10$	$V_S - 1.80$	$V_S - 1.67$	V	
Output Differential Voltage	V_{OD}	660	810	965	mV	
LVDS CLOCK OUTPUTS OUT4, OUT5, OUT6, OUT7; Differential						Termination = 100 Ω differential; default Output level Register 0x40, Register 0x41, Register 0x42, Register 0x43[2:1] = 01b 3.5 mA termination current See Figure 22
Output Frequency				800	MHz	
Differential Output Voltage	V_{OD}	250	360	450	mV	
Delta V_{OD}				25	mV	
Output Offset Voltage	V_{OS}	1.125	1.23	1.375	V	
Delta V_{OS}				25	mV	
Short-Circuit Current	I_{SA}, I_{SB}		14	24	mA	Output shorted to GND
CMOS CLOCK OUTPUTS OUT4, OUT5, OUT6, OUT7						Single-ended measurements, B outputs: inverted, termination open With 5 pF load each output, see Figure 23
Output Frequency				250	MHz	At 1 mA load
Output Voltage High	V_{OH}	$V_S - 0.1$			V	At 1 mA load
Output Voltage Low	V_{OL}			0.1	V	At 1 mA load

TIMING CHARACTERISTICS

Table 4.

Parameter	Symbol	Min	Typ	Max	Unit	Test Conditions/Comments
LVPECL						Termination = 50 Ω to $V_S - 2V$; output level Register 0x3C, Register 0x3D, Register 0x3E, Register 0x3F[3:2] = 10b
Output Rise Time	t_{RP}		130	180	ps	20% to 80%, measured differentially
Output Fall Time	t_{FP}		130	180	ps	80% to 20%, measured differentially
PROPAGATION DELAY, CLK-TO-LVPECL OUT ¹	t_{PECL}					
Divide = Bypass		335	490	635	ps	
Divide = 2 – 32		375	545	695	ps	
Variation with Temperature			0.5		ps/ $^{\circ}C$	
OUTPUT SKEW, LVPECL OUTPUTS						
OUT1 to OUT0 on Same Part ²	t_{SKP}	-5	+30	+85	ps	
OUT2 to OUT3 on Same Part ²	t_{SKP}	15	45	80	ps	
All LVPECL OUTs on Same Part ²	t_{SKP}	90	130	180	ps	
All LVPECL OUTs Across Multiple Parts ³	t_{SKP_AB}			275	ps	
Same LVPECL OUT Across Multiple Parts ³	t_{SKP_AB}			130	ps	
LVDS						Termination = 100 Ω differential; output level Register 0x40, Register 0x41, Register 0x42, Register 0x43[2:1] = 01b; 3.5 mA termination current
Output Rise Time	t_{RL}		200	350	ps	20% to 80%, measured differentially
Output Fall Time	t_{FL}		210	350	ps	80% to 20%, measured differentially

Parameter	Symbol	Min	Typ	Max	Unit	Test Conditions/Comments
PROPAGATION DELAY, CLK-TO-LVDS OUT ¹ OUT4, OUT5, OUT6, OUT7 Divide = Bypass Divide = 2 – 32 Variation with Temperature	t _{LVDS}	0.99 1.04	1.33 1.38	1.59 1.64	ns ns ps/°C	Delay off on OUT5 and OUT6
OUTPUT SKEW, LVDS OUTPUTS OUT4 to OUT7 on Same Part ² OUT5 to OUT6 on Same Part ² All LVDS OUTs on Same Part ² All LVDS OUTs Across Multiple Parts ³ Same LVDS OUT Across Multiple Parts ³	t _{SKV} t _{SKV} t _{SKV} t _{SKV_AB} t _{SKV_AB}	–85 –175 –175		+270 +155 +270 450 325	ps ps ps ps ps	Delay off on OUT5 and OUT6
CMOS Output Rise Time Output Fall Time	t _{RC} t _{FC}		681 646	865 992	ps ps	B outputs are inverted, termination = open 20% to 80%; C _{LOAD} = 3 pF 80% to 20%; C _{LOAD} = 3 pF
PROPAGATION DELAY, CLK-TO-CMOS OUT ¹ Divide = Bypass Divide = 2 – 32 Variation with Temperature	t _{CMOS}	1.02 1.07	1.39 1.44	1.71 1.76	ns ns ps/°C	Delay off on OUT5 and OUT6
OUTPUT SKEW, CMOS OUTPUTS All CMOS OUTs on Same Part ² All CMOS OUTs Across Multiple Parts ³ Same CMOS OUT Across Multiple Parts ³	t _{SKC} t _{SKC_AB} t _{SKC_AB}	–140	+145	+300 650 500	ps ps ps	Delay off on OUT5 and OUT6
LVPECL-TO-LVDS OUT Output Skew	t _{SKP_V}	0.74	0.92	1.14	ns	Everything the same; different logic type LVPECL to LVDS on same part
LVPECL-TO-CMOS OUT Output Skew	t _{SKP_C}	0.88	1.14	1.43	ns	Everything the same; different logic type LVPECL to CMOS on same part
LVDS-TO-CMOS OUT Output Skew	t _{SKV_C}	158	353	506	ps	Everything the same; different logic type LVDS to CMOS on same part
DELAY ADJUST ⁴ Shortest Delay Range ⁵ Zero Scale Full Scale Linearity, DNL Linearity, INL Longest Delay Range ⁵ Zero Scale Full Scale Linearity, DNL Linearity, INL Delay Variation with Temperature Long Delay Range, 8 ns ⁶ Zero Scale Full Scale Short Delay Range, 1 ns ⁶ Zero Scale Full Scale		0.05 0.57	0.36 0.95 0.5 0.8	0.68 1.32	ns ns LSB LSB ns ns LSB LSB ps/°C ps/°C ps/°C ps/°C	OUT5 (OUT6); LVDS and CMOS Register 0x35, Register 0x39[5:1] = 11111b Register 0x36, Register 0x3A[5:1] = 00000b Register 0x36, Register 0x3A[5:1] = 11000b Register 0x35, Register 0x39[5:1] = 00000b Register 0x36, Register 0x3A[5:1] = 00000b Register 0x36, Register 0x3A[5:1] = 11000b

¹ These measurements are for CLK1. For CLK2, add approximately 25 ps.

² This is the difference between any two similar delay paths within a single device operating at the same voltage and temperature.

³ This is the difference between any two similar delay paths across multiple devices operating at the same voltage and temperature.

⁴ The maximum delay that can be used is a little less than one half the period of the clock. A longer delay disables the output.

⁵ Incremental delay; does not include propagation delay.

⁶ All delays between zero scale and full scale can be estimated by linear interpolation.

CLOCK OUTPUT PHASE NOISE

Table 5.

Parameter	Min	Typ	Max	Unit	Test Conditions/Comments
CLK1-TO-LVPECL ADDITIVE PHASE NOISE					Distribution Section only, does not include PLL or external VCO/VCXO Input slew rate > 1 V/ns
CLK1 = 622.08 MHz, OUT = 622.08 MHz					
Divide Ratio = 1					
At 10 Hz Offset		-125		dBc/Hz	
At 100 Hz Offset		-132		dBc/Hz	
At 1 kHz Offset		-140		dBc/Hz	
At 10 kHz Offset		-148		dBc/Hz	
At 100 kHz Offset		-153		dBc/Hz	
>1 MHz Offset		-154		dBc/Hz	
CLK1 = 622.08 MHz, OUT = 155.52 MHz					
Divide Ratio = 4					
At 10 Hz Offset		-128		dBc/Hz	
At 100 Hz Offset		-140		dBc/Hz	
At 1 kHz Offset		-148		dBc/Hz	
At 10 kHz Offset		-155		dBc/Hz	
At 100 kHz Offset		-161		dBc/Hz	
>1 MHz Offset		-161		dBc/Hz	
CLK1 = 622.08 MHz, OUT = 38.88 MHz					
Divide Ratio = 16					
At 10 Hz Offset		-135		dBc/Hz	
At 100 Hz Offset		-145		dBc/Hz	
At 1 kHz Offset		-158		dBc/Hz	
At 10 kHz Offset		-165		dBc/Hz	
At 100 kHz Offset		-165		dBc/Hz	
>1 MHz Offset		-166		dBc/Hz	
CLK1 = 491.52 MHz, OUT = 61.44 MHz					
Divide Ratio = 8					
At 10 Hz Offset		-131		dBc/Hz	
At 100 Hz Offset		-142		dBc/Hz	
At 1 kHz Offset		-153		dBc/Hz	
At 10 kHz Offset		-160		dBc/Hz	
At 100 kHz Offset		-165		dBc/Hz	
> 1 MHz Offset		-165		dBc/Hz	
CLK1 = 491.52 MHz, OUT = 245.76 MHz					
Divide Ratio = 2					
At 10 Hz Offset		-125		dBc/Hz	
At 100 Hz Offset		-132		dBc/Hz	
At 1 kHz Offset		-140		dBc/Hz	
At 10 kHz Offset		-151		dBc/Hz	
At 100 kHz Offset		-157		dBc/Hz	
>1 MHz Offset		-158		dBc/Hz	
CLK1 = 245.76 MHz, OUT = 61.44 MHz					
Divide Ratio = 4					
At 10 Hz Offset		-138		dBc/Hz	
At 100 Hz Offset		-144		dBc/Hz	
At 1 kHz Offset		-154		dBc/Hz	
At 10 kHz Offset		-163		dBc/Hz	
At 100 kHz Offset		-164		dBc/Hz	
>1 MHz Offset		-165		dBc/Hz	

Parameter	Min	Typ	Max	Unit	Test Conditions/Comments
CLK1-TO-LVDS ADDITIVE PHASE NOISE					Distribution Section only; does not include PLL or external VCO/VCXO
CLK1 = 622.08 MHz, OUT = 622.08 MHz					
Divide Ratio = 1					
At 10 Hz Offset		-100		dBc/Hz	
At 100 Hz Offset		-110		dBc/Hz	
At 1 kHz Offset		-118		dBc/Hz	
At 10 kHz Offset		-129		dBc/Hz	
At 100 kHz Offset		-135		dBc/Hz	
At 1 MHz Offset		-140		dBc/Hz	
>10 MHz Offset		-148		dBc/Hz	
CLK1 = 622.08 MHz, OUT = 155.52 MHz					
Divide Ratio = 4					
At 10 Hz Offset		-112		dBc/Hz	
At 100 Hz Offset		-122		dBc/Hz	
At 1 kHz Offset		-132		dBc/Hz	
At 10 kHz Offset		-142		dBc/Hz	
At 100 kHz Offset		-148		dBc/Hz	
At 1 MHz Offset		-152		dBc/Hz	
>10 MHz Offset		-155		dBc/Hz	
CLK1 = 491.52 MHz, OUT = 245.76 MHz					
Divide Ratio = 2					
At 10 Hz Offset		-108		dBc/Hz	
At 100 Hz Offset		-118		dBc/Hz	
At 1 kHz Offset		-128		dBc/Hz	
At 10 kHz Offset		-138		dBc/Hz	
At 100 kHz Offset		-145		dBc/Hz	
At 1 MHz Offset		-148		dBc/Hz	
>10 MHz Offset		-154		dBc/Hz	
CLK1 = 491.52 MHz, OUT = 122.88 MHz					
Divide Ratio = 4					
At 10 Hz Offset		-118		dBc/Hz	
At 100 Hz Offset		-129		dBc/Hz	
At 1 kHz Offset		-136		dBc/Hz	
At 10 kHz Offset		-147		dBc/Hz	
At 100 kHz Offset		-153		dBc/Hz	
At 1 MHz Offset		-156		dBc/Hz	
>10 MHz Offset		-158		dBc/Hz	
CLK1 = 245.76 MHz, OUT = 245.76 MHz					
Divide Ratio = 1					
At 10 Hz Offset		-108		dBc/Hz	
At 100 Hz Offset		-118		dBc/Hz	
At 1 kHz Offset		-128		dBc/Hz	
At 10 kHz Offset		-138		dBc/Hz	
At 100 kHz Offset		-145		dBc/Hz	
At 1 MHz Offset		-148		dBc/Hz	
>10 MHz Offset		-155		dBc/Hz	

Parameter	Min	Typ	Max	Unit	Test Conditions/Comments
CLK1 = 245.76 MHz, OUT = 122.88 MHz Divide Ratio = 2 At 10 Hz Offset At 100 Hz Offset At 1 kHz Offset At 10 kHz Offset At 100 kHz Offset At 1 MHz Offset >10 MHz Offset		-118 -127 -137 -147 -154 -156 -158		dBc/Hz dBc/Hz dBc/Hz dBc/Hz dBc/Hz dBc/Hz dBc/Hz	
CLK1-TO-CMOS ADDITIVE PHASE NOISE					Distribution Section only, does not include PLL or external VCO/VCXO
CLK1 = 245.76 MHz, OUT = 245.76 MHz Divide Ratio = 1 At 10 Hz Offset At 100 Hz Offset At 1 kHz Offset At 10 kHz Offset At 100 kHz Offset At 1 MHz Offset >10 MHz Offset		-110 -121 -130 -140 -145 -149 -156		dBc/Hz dBc/Hz dBc/Hz dBc/Hz dBc/Hz dBc/Hz dBc/Hz	
CLK1 = 245.76 MHz, OUT = 61.44 MHz Divide Ratio = 4 At 10 Hz Offset At 100 Hz Offset At 1 kHz Offset At 10 kHz Offset At 100 kHz Offset At 1 MHz Offset >10 MHz Offset		-122 -132 -143 -152 -158 -160 -162		dBc/Hz dBc/Hz dBc/Hz dBc/Hz dBc/Hz dBc/Hz dBc/Hz	
CLK1 = 78.6432 MHz, OUT = 78.6432 MHz Divide Ratio = 1 At 10 Hz Offset At 100 Hz Offset At 1 kHz Offset At 10 kHz Offset At 100 kHz Offset At 1 MHz Offset >10 MHz Offset		-122 -132 -140 -150 -155 -158 -160		dBc/Hz dBc/Hz dBc/Hz dBc/Hz dBc/Hz dBc/Hz dBc/Hz	
CLK1 = 78.6432 MHz, OUT = 39.3216 MHz Divide Ratio = 2 At 10 Hz Offset At 100 Hz Offset At 1 kHz Offset At 10 kHz Offset At 100 kHz Offset >1 MHz Offset		-128 -136 -146 -155 -161 -162		dBc/Hz dBc/Hz dBc/Hz dBc/Hz dBc/Hz dBc/Hz	

CLOCK OUTPUT ADDITIVE TIME JITTER

Table 6.

Parameter	Min	Typ	Max	Unit	Test Conditions/Comments
LVPECL OUTPUT ADDITIVE TIME JITTER					Distribution Section only, does not include PLL or external VCO/VCXO
CLK1 = 622.08 MHz Any LVPECL (OUT0 to OUT3) = 622.08 MHz Divide Ratio = 1		40		fs rms	Bandwidth = 12 kHz – 20 MHz (OC-12)
CLK1 = 622.08 MHz Any LVPECL (OUT0 to OUT3) = 155.52 MHz Divide Ratio = 4		55		fs rms	Bandwidth = 12 kHz – 20 MHz (OC-3)
CLK1 = 400 MHz Any LVPECL (OUT0 to OUT3) = 100 MHz Divide Ratio = 4		215		fs rms	Calculated from signal-to-noise ratio (SNR) of ADC method, $f_c = 100$ MHz with $A_{IN} = 170$ MHz
CLK1 = 400 MHz Any LVPECL (OUT0 to OUT3) = 100 MHz Divide Ratio = 4 All Other LVPECL = 100 MHz All LVDS (OUT4 to OUT7) = 100 MHz		215		fs rms	Calculated from SNR of ADC method, $f_c = 100$ MHz with $A_{IN} = 170$ MHz Interferer(s) Interferer(s)
CLK1 = 400 MHz Any LVPECL (OUT0 to OUT3) = 100 MHz Divide Ratio = 4 All Other LVPECL = 50 MHz All LVDS (OUT4 to OUT7) = 50 MHz		222		fs rms	Calculated from SNR of ADC method, $f_c = 100$ MHz with $A_{IN} = 170$ MHz Interferer(s) Interferer(s)
CLK1 = 400 MHz Any LVPECL (OUT0 to OUT3) = 100 MHz Divide Ratio = 4 All Other LVPECL = 50 MHz All LVDS (OUT4 to OUT7) = 50 MHz		225		fs rms	Calculated from SNR of ADC method; $f_c = 100$ MHz with $A_{IN} = 170$ MHz Interferer(s) Interferer(s)
CLK1 = 400 MHz Any LVPECL (OUT0 to OUT3) = 100 MHz Divide Ratio = 4 All Other LVPECL = 50 MHz All CMOS (OUT4 to OUT7) = 50 MHz (B Outputs Off)		225		fs rms	Calculated from SNR of ADC method, $f_c = 100$ MHz with $A_{IN} = 170$ MHz Interferer(s) Interferer(s)
CLK1 = 400 MHz Any LVPECL (OUT0 to OUT3) = 100 MHz Divide Ratio = 4 All Other LVPECL = 50 MHz All CMOS (OUT4 to OUT7) = 50 MHz (B Outputs On)		225		fs rms	Calculated from SNR of ADC method, $f_c = 100$ MHz with $A_{IN} = 170$ MHz Interferer(s) Interferer(s)
LVDS OUTPUT ADDITIVE TIME JITTER					Distribution Section only, does not include PLL or external VCO/VCXO
CLK1 = 400 MHz LVDS (OUT4, OUT7) = 100 MHz Divide Ratio = 4		264		fs rms	Calculated from SNR of ADC method, $f_c = 100$ MHz with $A_{IN} = 170$ MHz
CLK1 = 400 MHz LVDS (OUT5, OUT6) = 100 MHz Divide Ratio = 4		319		fs rms	Calculated from SNR of ADC method, $f_c = 100$ MHz with $A_{IN} = 170$ MHz

Parameter	Min	Typ	Max	Unit	Test Conditions/Comments
CLK1 = 400 MHz LVDS (OUT4, OUT7) = 100 MHz Divide Ratio = 4 All Other LVDS = 50 MHz All LVPECL = 50 MHz		395		fs rms	Calculated from SNR of ADC method, $f_c = 100$ MHz with $A_{IN} = 170$ MHz
CLK1 = 400 MHz LVDS (OUT5, OUT6) = 100 MHz Divide Ratio = 4 All Other LVDS = 50 MHz All LVPECL = 50 MHz		395		fs rms	Interferer(s) Interferer(s) Calculated from SNR of ADC method, $f_c = 100$ MHz with $A_{IN} = 170$ MHz
CLK1 = 400 MHz LVDS (OUT4, OUT7) = 100 MHz Divide Ratio = 4 All Other CMOS = 50 MHz (B Outputs Off) All LVPECL = 50 MHz		367		fs rms	Interferer(s) Interferer(s) Calculated from SNR of ADC method, $f_c = 100$ MHz with $A_{IN} = 170$ MHz
CLK1 = 400 MHz LVDS (OUT5, OUT6) = 100 MHz Divide Ratio = 4 All Other CMOS = 50 MHz (B Outputs Off) All LVPECL = 50 MHz		367		fs rms	Interferer(s) Interferer(s) Calculated from SNR of ADC method, $f_c = 100$ MHz with $A_{IN} = 170$ MHz
CLK1 = 400 MHz LVDS (OUT4, OUT7) = 100 MHz Divide Ratio = 4 All Other CMOS = 50 MHz (B Outputs On) All LVPECL = 50 MHz		548		fs rms	Interferer(s) Interferer(s) Calculated from SNR of ADC method, $f_c = 100$ MHz with $A_{IN} = 170$ MHz
CLK1 = 400 MHz LVDS (OUT5, OUT6) = 100 MHz Divide Ratio = 4 All Other CMOS = 50 MHz (B Outputs On) All LVPECL = 50 MHz		548		fs rms	Interferer(s) Interferer(s) Calculated from SNR of ADC method, $f_c = 100$ MHz with $A_{IN} = 170$ MHz
CMOS OUTPUT ADDITIVE TIME JITTER					Distribution Section only, does not include PLL or external VCO/VCXO
CLK1 = 400 MHz Any CMOS (OUT4 to OUT7) = 100 MHz (B Output On) Divide Ratio = 4		275		fs rms	Calculated from SNR of ADC method, $f_c = 100$ MHz with $A_{IN} = 170$ MHz
CLK1 = 400 MHz Any CMOS (OUT4 to OUT7) = 100 MHz (B Output On) Divide Ratio = 4 All LVPECL = 50 MHz All Other LVDS = 50 MHz		400		fs rms	Calculated from SNR of ADC method, $f_c = 100$ MHz with $A_{IN} = 170$ MHz Interferer(s) Interferer(s)
CLK1 = 400 MHz Any CMOS (OUT4 to OUT7) = 100 MHz (B Output On) Divide Ratio = 4 All LVPECL = 50 MHz All Other CMOS = 50 MHz (B Output Off)		374		fs rms	Calculated from SNR of ADC method, $f_c = 100$ MHz with $A_{IN} = 170$ MHz Interferer(s) Interferer(s)

Parameter	Min	Typ	Max	Unit	Test Conditions/Comments
CLK1 = 400 MHz Any CMOS (OUT4 to OUT7) = 100 MHz (B Output On) Divide Ratio = 4 All LVPECL = 50 MHz All Other CMOS = 50 MHz (B Output On)		555		fs rms	Calculated from SNR of ADC method, $f_c = 100$ MHz with $A_{IN} = 170$ MHz Interferer(s) Interferer(s)
DELAY BLOCK ADDITIVE TIME JITTER ¹ 100 MHz Output Delay FS = 1 ns (1600 μ A, 1C) Fine Adjust 00000 Delay FS = 1 ns (1600 μ A, 1C) Fine Adjust 11000 Delay FS = 2 ns (800 μ A, 1C) Fine Adjust 00000 Delay FS = 2 ns (800 μ A, 1C) Fine Adjust 11000 Delay FS = 3 ns (800 μ A, 4C) Fine Adjust 00000 Delay FS = 3 ns (800 μ A, 4C) Fine Adjust 11000 Delay FS = 5 ns (400 μ A, 4C) Fine Adjust 00000 Delay FS = 5 ns (400 μ A, 4C) Fine Adjust 11000 Delay FS = 6 ns (200 μ A, 1C) Fine Adjust 00000 Delay FS = 6 ns (200 μ A, 1C) Fine Adjust 11000 Delay FS = 9 ns (200 μ A, 4C) Fine Adjust 00000 Delay FS = 9 ns (200 μ A, 4C) Fine Adjust 00111					Incremental additive jitter ¹

¹ This value is incremental. That is, it is in addition to the jitter of the LVDS or CMOS output without the delay. To estimate the total jitter, add the LVDS or CMOS output jitter to this value using the root sum of the squares (RSS) method.

PLL AND DISTRIBUTION PHASE NOISE AND SPURIOUS

Table 7.

Parameter	Min	Typ	Max	Unit	Test Conditions/Comments
PHASE NOISE AND SPURIOUS					Depends on VCO/VCXO selection; measured at LVPECL clock outputs, ABP = 6 ns; $I_{CP} = 5$ mA; Ref = 30.72 MHz
VCXO = 245.76 MHz, $f_{PFD} = 1.2288$ MHz, R = 25, N = 200 245.76 MHz Output Phase Noise at 100 kHz Offset Spurious 61.44 MHz Output Phase Noise at 100 kHz Offset Spurious					VCXO = Toyocom TCO-2112 245.76 Divide by 1 Dominated by VCXO phase noise First and second harmonics of f_{PFD} ; below measurement floor Divide by 4 Dominated by VCXO phase noise First and second harmonics of f_{PFD} ; below measurement floor

SERIAL CONTROL PORT

Table 8.

Parameter	Min	Typ	Max	Unit	Test Conditions/Comments
CSB, SCLK (INPUTS)					Inputs have 30 k Ω internal pull-down resistors
Input Logic 1 Voltage	2.0			V	
Input Logic 0 Voltage			0.8	V	
Input Logic 1 Current		110		μ A	
Input Logic 0 Current			1	μ A	
Input Capacitance		2		pF	

Parameter	Min	Typ	Max	Unit	Test Conditions/Comments
SDIO (WHEN INPUT)					
Input Logic 1 Voltage	2.0			V	
Input Logic 0 Voltage			0.8	V	
Input Logic 1 Current		10		nA	
Input Logic 0 Current		10		nA	
Input Capacitance		2		pF	
SDIO, SDO (OUTPUTS)					
Output Logic 1 Voltage	2.7			V	
Output Logic 0 Voltage			0.4	V	
TIMING					
Clock Rate (SCLK, $1/t_{SCLK}$)			25	MHz	
Pulse Width High, t_{PWH}	16			ns	
Pulse Width Low, t_{PWL}	16			ns	
SDIO to SCLK Setup, t_{DS}	2			ns	
SCLK to SDIO Hold, t_{DH}	1			ns	
SCLK to Valid SDIO and SDO, t_{DV}	6			ns	
CSB to SCLK Setup and Hold, t_s, t_H	2			ns	
CSB Minimum Pulse Width High, t_{PWH}	3			ns	

FUNCTION PIN

Table 9.

Parameter	Min	Typ	Max	Unit	Test Conditions/Comments
INPUT CHARACTERISTICS					FUNCTION pin has 30 k Ω internal pull-down resistor; normally, hold this pin high; do not leave unconnected
Logic 1 Voltage	2.0			V	
Logic 0 Voltage			0.8	V	
Logic 1 Current		110		μ A	
Logic 0 Current		1		μ A	
Capacitance		2		pF	
RESET TIMING					
Pulse Width Low	50			ns	
SYNC TIMING					
Pulse Width Low	1.5			High speed clock cycles	High speed clock is CLK1 or CLK2, whichever is being used for distribution

STATUS PIN

Table 10.

Parameter	Min	Typ	Max	Unit	Test Conditions/Comments
OUTPUT CHARACTERISTICS					When selected as a digital output (CMOS), there are other modes in which the STATUS pin is not CMOS digital output; see Figure 37
Output Voltage High (V_{OH})	2.7			V	
Output Voltage Low (V_{OL})			0.4	V	
MAXIMUM TOGGLE RATE		100		MHz	Applies when PLL mux is set to any divider or counter output, or PFD up/down pulse; also applies in analog lock detect mode; usually debug mode only; beware that spurs can couple to output when this pin is toggling
ANALOG LOCK DETECT					
Capacitance		3		pF	On-chip capacitance, used to calculate RC time constant for analog lock detect readback; use a pull-up resistor

POWER

Table 11.

Parameter	Min	Typ	Max	Unit	Test Conditions/Comments
POWER-UP DEFAULT MODE POWER DISSIPATION		550	600	mW	Power-up default state, does not include power dissipated in output load resistors; no clock
Power Dissipation			1.1	W	All outputs on; four LVPECL outputs at 800 MHz, 4 LVDS out at 800 MHz; does not include power dissipated in external resistors
Power Dissipation			1.3	W	All outputs on; four LVPECL outputs at 800 MHz, 4 CMOS out at 62 MHz (5 pF load); does not include power dissipated in external resistors
Power Dissipation			1.5	W	All outputs on; four LVPECL outputs at 800 MHz, 4 CMOS out at 125 MHz (5 pF load); does not include power dissipated in external resistors
Full Sleep Power-Down		35	60	mW	Maximum sleep is entered by setting Register 0x0A[1:0] = 01b and Register 0x58[4] = 1b; this powers off the PLL BG and the distribution BG references; does not include power dissipated in terminations
Power-Down (PDB)		60	80	mW	Set the FUNCTION pin for PDB operation by setting Register 0x58[6:5] = 11b; pull PDB low; does not include power dissipated in terminations
POWER DELTA					
CLK1, CLK2 Power-Down	10	15	25	mW	
Divider, DIV 2 – 32 to Bypass	23	27	33	mW	For each divider
LVPECL Output Power-Down (PD2, PD3)	50	65	75	mW	For each output; does not include dissipation in termination (PD2 only)
LVDS Output Power-Down	80	92	110	mW	For each output
CMOS Output Power-Down (Static)	56	70	85	mW	For each output; static (no clock)
CMOS Output Power-Down (Dynamic)	115	150	190	mW	For each CMOS output, single-ended; clocking at 62 MHz with 5 pF load
CMOS Output Power-Down (Dynamic)	125	165	210	mW	For each CMOS output, single-ended; clocking at 125 MHz with 5 pF load
Delay Block Bypass	20	24	60	mW	Versus delay block operation at 1 ns fs with maximum delay, output clocking at 25 MHz
PLL Section Power-Down	5	15	40	mW	

TIMING DIAGRAMS

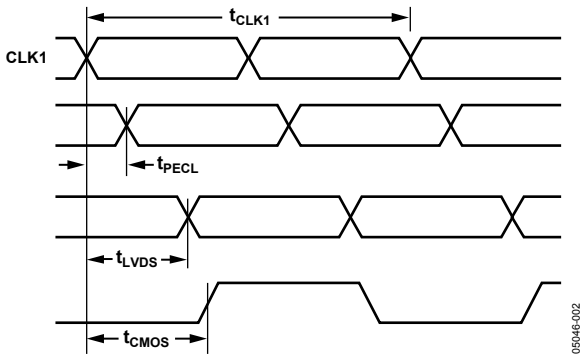

Figure 2. CLK1/CLK1B to Clock Output Timing, DIV = 1 Mode

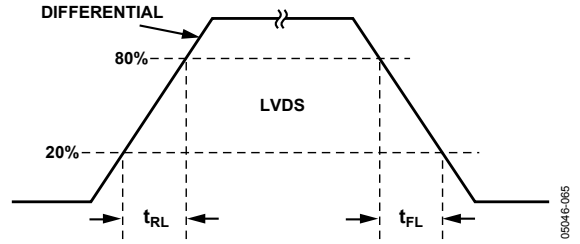

Figure 4. LVDS Timing, Differential

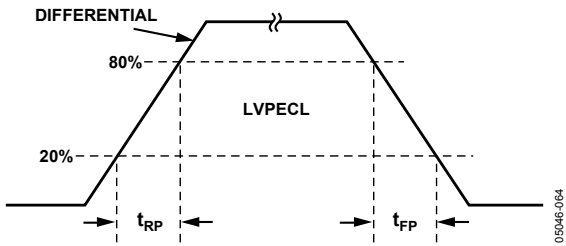

Figure 3. LVPECL Timing, Differential

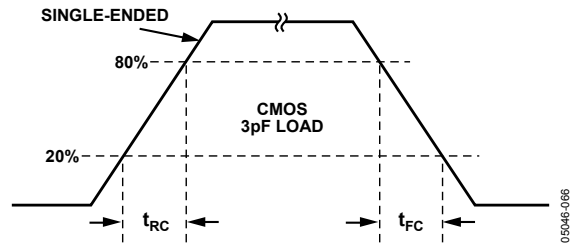

Figure 5. CMOS Timing, Single-Ended, 3 pF Load

ABSOLUTE MAXIMUM RATINGS

Table 12.

Parameter	Value
V _S to GND	−0.3 V to +3.6 V
V _{CP} to GND	−0.3 V to +5.8 V
V _{CP} to V _S	−0.3 V to +5.8 V
REFIN, REFINB to GND	−0.3 V to V _S + 0.3 V
RSET to GND	−0.3 V to V _S + 0.3 V
CPRSET to GND	−0.3 V to V _S + 0.3 V
CLK1, CLK1B, CLK2, CLK2B to GND	−0.3 V to V _S + 0.3 V
CLK1 to CLK1B	−1.2 V to +1.2 V
CLK2 to CLK2B	−1.2 V to +1.2 V
SCLK, SDIO, SDO, CSB to GND	−0.3 V to V _S + 0.3 V
OUT0, OUT1, OUT2, OUT3 to GND	−0.3 V to V _S + 0.3 V
OUT4, OUT5, OUT6, OUT7 to GND	−0.3 V to V _S + 0.3 V
FUNCTION to GND	−0.3 V to V _S + 0.3 V
STATUS to GND	−0.3 V to V _S + 0.3 V
Junction Temperature ¹	150°C
Storage Temperature	−65°C to +150°C
Lead Temperature (10 sec)	300°C

¹ See Thermal Characteristics for θ_{JA}

Stresses at or above those listed under Absolute Maximum Ratings may cause permanent damage to the product. This is a stress rating only; functional operation of the product at these or any other conditions above those indicated in the operational section of this specification is not implied. Operation beyond the maximum operating conditions for extended periods may affect product reliability.

THERMAL CHARACTERISTICS

Thermal impedance measurements were taken on a 4-layer board in still air in accordance with EIA/JESD51-7.

Table 13. Thermal Resistance

Package	θ_{JA}	Unit
64-Lead LFCSP	24	°C/W

ESD CAUTION



ESD (electrostatic discharge) sensitive device. Charged devices and circuit boards can discharge without detection. Although this product features patented or proprietary protection circuitry, damage may occur on devices subjected to high energy ESD. Therefore, proper ESD precautions should be taken to avoid performance degradation or loss of functionality.

PIN CONFIGURATION AND FUNCTION DESCRIPTIONS

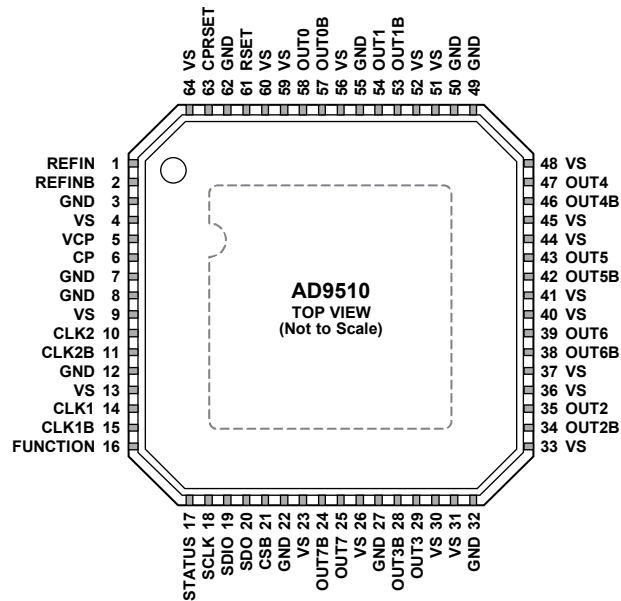

NOTES

1. THE EXPOSED PADDLE ON THIS PACKAGE IS AN ELECTRICAL CONNECTION AS WELL AS A THERMAL ENHANCEMENT. FOR THE DEVICE TO FUNCTION PROPERLY, THE PADDLE MUST BE ATTACHED TO GROUND, GND.

06946-013

Figure 6.

Table 14. Pin Function Descriptions

Pin No.	Mnemonic	Description
1	REFIN	PLL Reference Input.
2	REFINB	Complementary PLL Reference Input.
3, 7, 8, 12, 22, 27, 32, 49, 50, 55, 62	GND	Ground.
4, 9, 13, 23, 26, 30, 31, 33, 36, 37, 40, 41, 44, 45, 48, 51, 52, 56, 59, 60, 64	VS	Power Supply (3.3 V) Vs.
5	VCP	Charge Pump Power Supply VCPs. It must be greater than or equal to Vs. VCPs can be set as high as 5.5 V for VCOs requiring extended tuning range.
6	CP	Charge Pump Output.
10	CLK2	Clock Input Used to Connect External VCO/VCXO to Feedback Divider, N. CLK2 also drives the distribution section of the chip and can be used as a generic clock input when PLL is not used.
11	CLK2B	Complementary Clock Input Used in Conjunction with CLK2.
14	CLK1	Clock Input that Drives Distribution Section of the Chip.
15	CLK1B	Complementary Clock Input Used in Conjunction with CLK1.
16	FUNCTION	Multipurpose Input Can Be Programmed as a Reset (RESETB), Sync (SYNCB), or Power-Down (PDB) Pin. This pin is internally pulled down by a 30 kΩ resistor. If this pin is left NC, the part is in reset by default. To avoid this, connect this pin to Vs with a 1 kΩ resistor.
17	STATUS	Output Used to Monitor PLL Status and Sync Status.
18	SCLK	Serial Data Clock.
19	SDIO	Serial Data I/O.
20	SDO	Serial Data Output.
21	CSB	Serial Port Chip Select.
24	OUT7B	Complementary LVDS/Inverted CMOS Output.
25	OUT7	LVDS/CMOS Output.

Pin No.	Mnemonic	Description
28	OUT3B	Complementary LVPECL Output.
29	OUT3	LVPECL Output.
34	OUT2B	Complementary LVPECL Output.
35	OUT2	LVPECL Output.
38	OUT6B	Complementary LVDS/Inverted CMOS Output. OUT6 includes a delay block.
39	OUT6	LVDS/CMOS Output. OUT6 includes a delay block.
42	OUT5B	Complementary LVDS/Inverted CMOS Output. OUT5 includes a delay block.
43	OUT5	LVDS/CMOS Output. OUT5 includes a delay block.
46	OUT4B	Complementary LVDS/Inverted CMOS Output.
47	OUT4	LVDS/CMOS Output.
53	OUT1B	Complementary LVPECL Output.
54	OUT1	LVPECL Output.
57	OUT0B	Complementary LVPECL Output.
58	OUT0	LVPECL Output.
61	RSET	Current Set Resistor to Ground. Nominal value = 4.12 k Ω .
63	CPRSET	Charge Pump Current Set Resistor to Ground. Nominal value = 5.1 k Ω .
	EPAD	Exposed Paddle. The exposed paddle on this package is an electrical connection as well as a thermal enhancement. For the device to function properly, the paddle must be attached to ground, GND.

TYPICAL PERFORMANCE CHARACTERISTICS

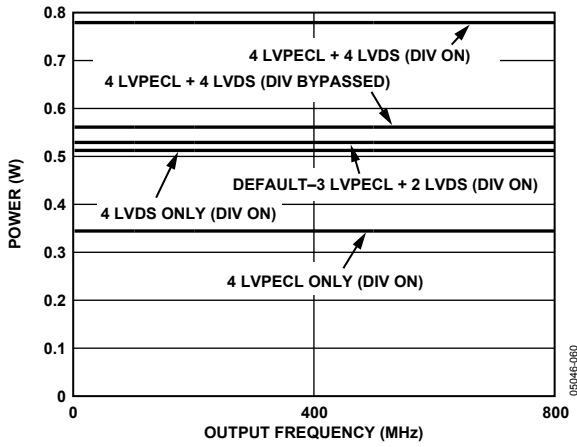

Figure 7. Power vs. Frequency—LVPECL, LVDS (PLL Off)

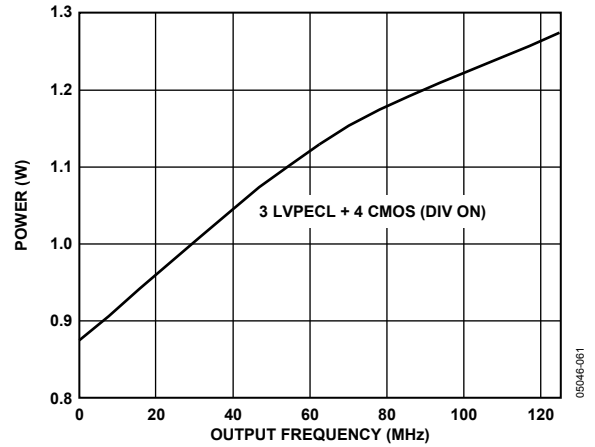

Figure 10. Power vs. Frequency—LVPECL, CMOS (PLL Off)

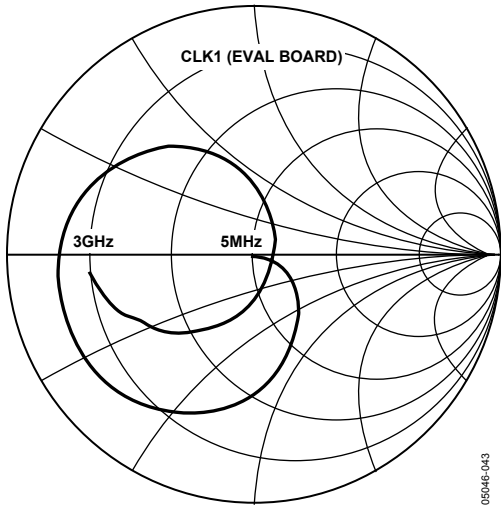

Figure 8. CLK1 Smith Chart (Evaluation Board)

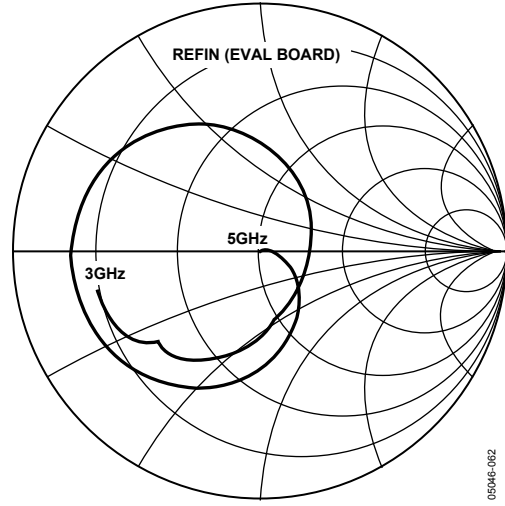

Figure 11. REFIN Smith Chart (Evaluation Board)

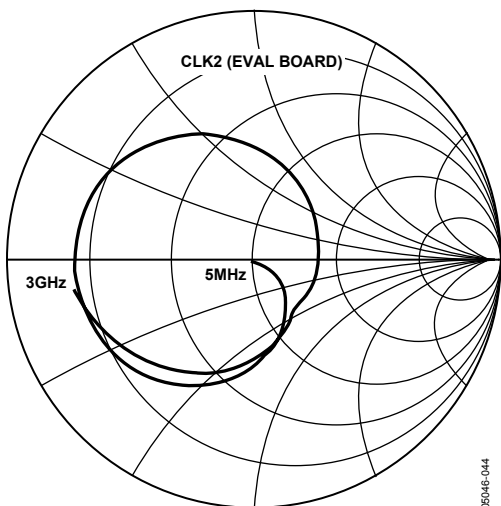

Figure 9. CLK2 Smith Chart (Evaluation Board)

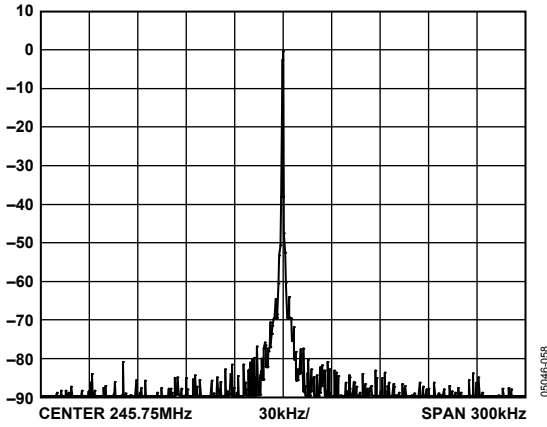

Figure 12. Phase Noise, LVPECL, DIV 1, $f_{VCO} = 245.76$ MHz, $f_{OUT} = 245.76$ MHz, $f_{PFD} = 1.2288$ MHz, $R = 25$, $N = 200$

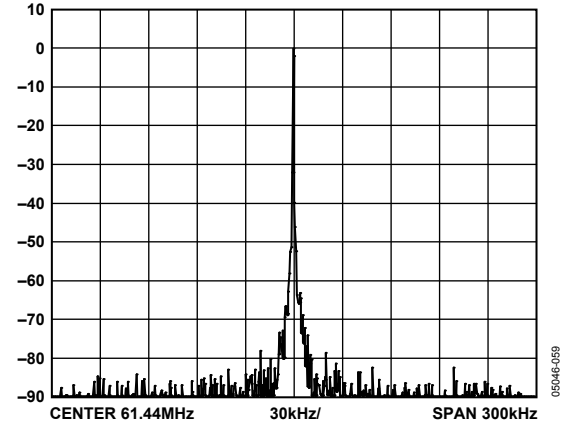

Figure 15. Phase Noise, LVPECL, DIV 4, $f_{VCO} = 245.76$ MHz, $f_{OUT} = 61.44$ MHz, $f_{PFD} = 1.2288$ MHz, $R = 25$, $N = 200$

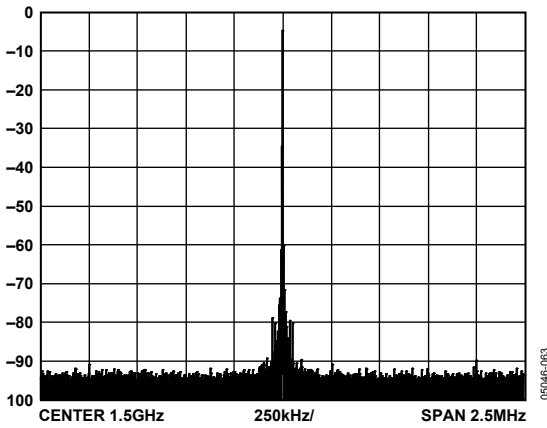

Figure 13. PLL Reference Spurs: $VCO = 1.5$ GHz, $f_{PFD} = 1$ MHz

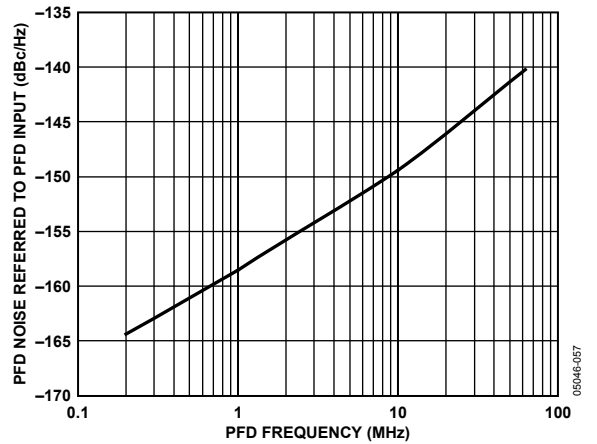

Figure 16. Phase Noise (Referred to CP Output) vs. PFD Frequency (f_{PFD})

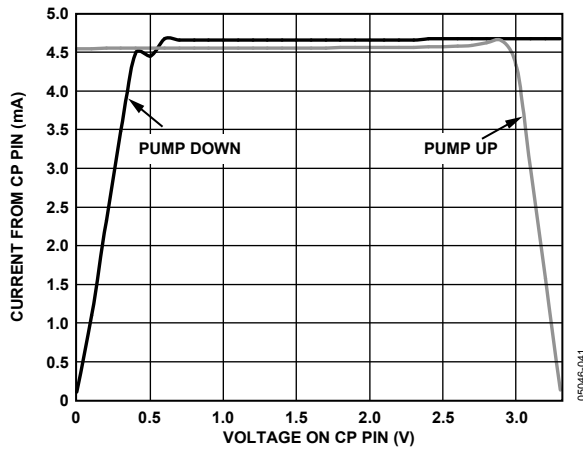

Figure 14. Charge Pump Output Characteristics at $VCPs = 3.3$ V

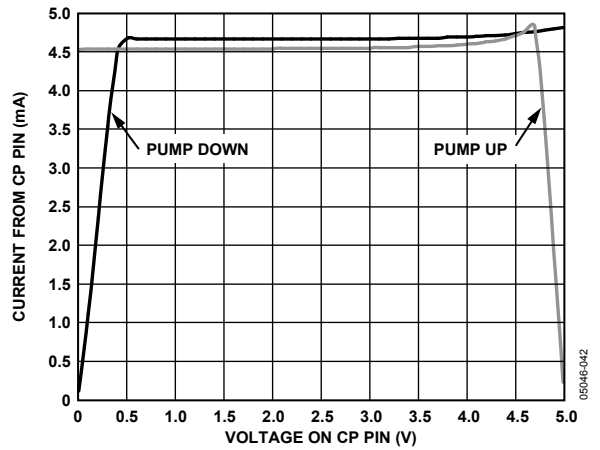

Figure 17. Charge Pump Output Characteristics at $VCPs = 5.0$ V

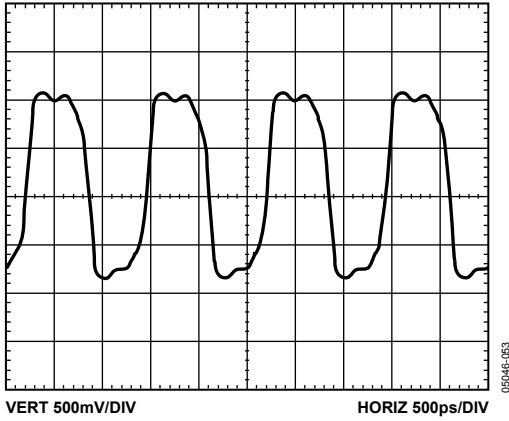

Figure 18. LVPECL Differential Output at 800 MHz

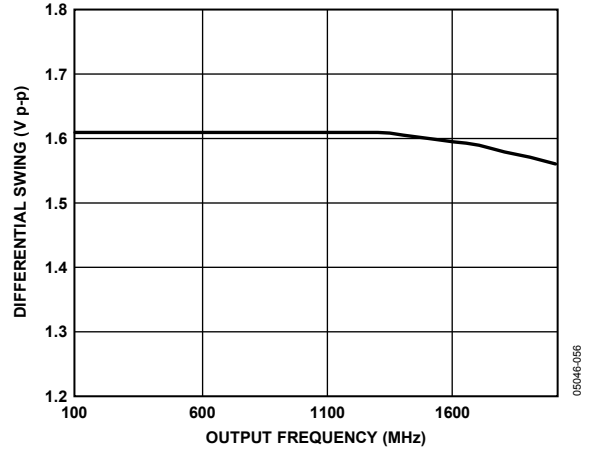

Figure 21. LVPECL Differential Output Swing vs. Frequency

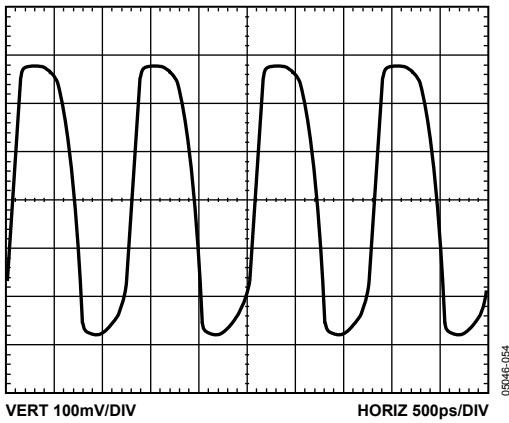

Figure 19. LVDS Differential Output at 800 MHz

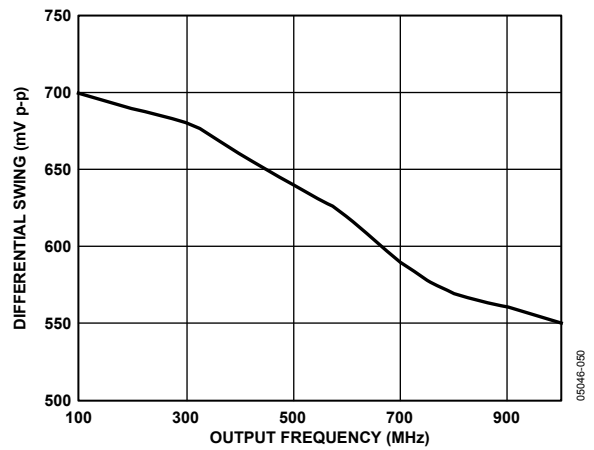

Figure 22. LVDS Differential Output Swing vs. Frequency

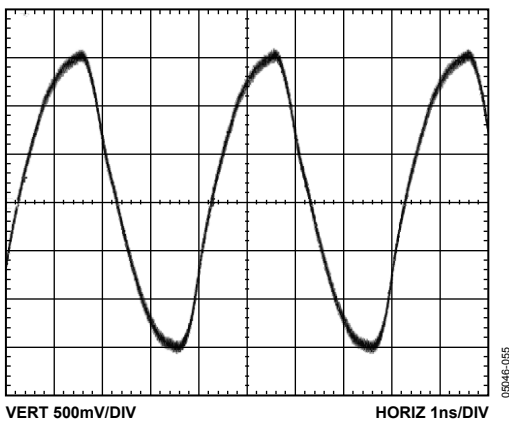

Figure 20. CMOS Single-Ended Output at 250 MHz with 10 pF Load

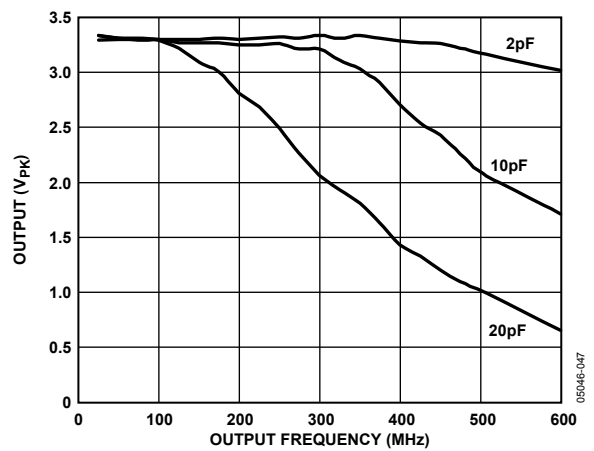

Figure 23. CMOS Single-Ended Output Swing vs. Frequency and Load

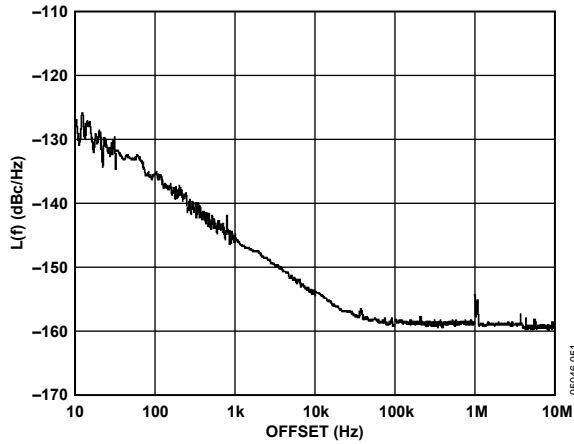

Figure 24. Additive Phase Noise—LVPECL DIV 1, 245.76 MHz, Distribution Section Only

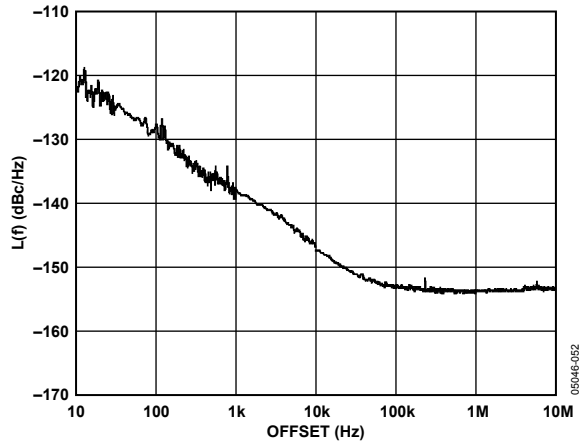

Figure 27. Additive Phase Noise—LVPECL DIV1, 622.08 MHz

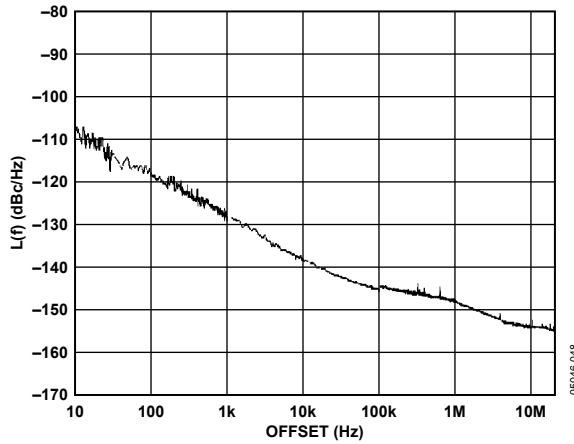

Figure 25. Additive Phase Noise—LVDS DIV 1, 245.76 MHz

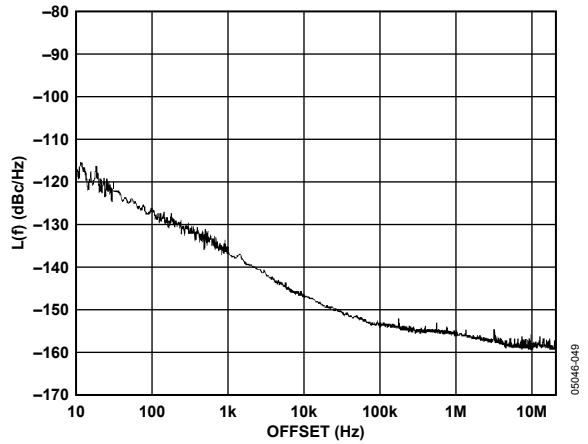

Figure 28. Additive Phase Noise—LVDS DIV2, 122.88 MHz

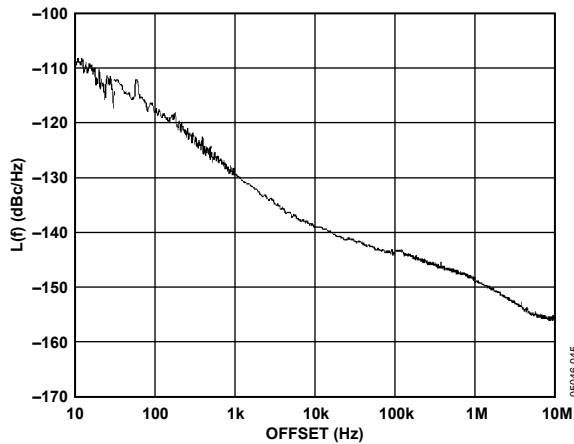

Figure 26. Additive Phase Noise—CMOS DIV 1, 245.76 MHz

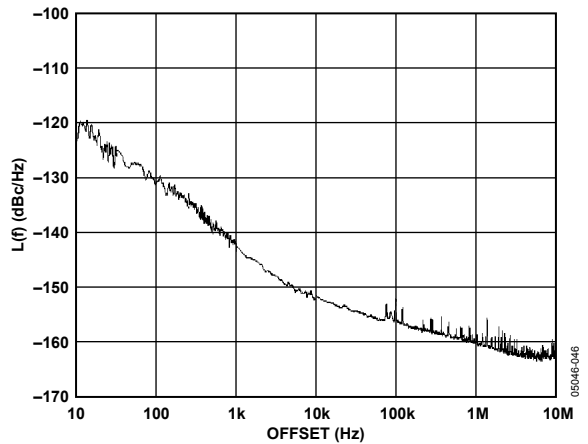

Figure 29. Additive Phase Noise—CMOS DIV4, 61.44 MHz

TERMINOLOGY

Phase Jitter and Phase Noise

An ideal sine wave has a continuous and even progression of phase with time from 0 to 360 degrees for each cycle. Actual signals, however, display a certain amount of variation from ideal phase progression over time. This phenomenon is called phase jitter. Although many causes can contribute to phase jitter, one major cause is random noise, which is characterized statistically as being Gaussian (normal) in distribution.

This phase jitter leads to a spreading out of the energy of the sine wave in the frequency domain, producing a continuous power spectrum. This power spectrum is usually reported as a series of values whose units are dBc/Hz at a given offset in frequency from the sine wave (carrier). The value is a ratio, expressed in dB, of the power contained within a 1 Hz bandwidth with respect to the power at the carrier frequency. For each measurement, the offset from the carrier frequency is also given.

It is meaningful to integrate the total power contained within some interval of offset frequencies (for example, 10 kHz to 10 MHz). This is called the integrated phase noise over that frequency offset interval and can be readily related to the time jitter due to the phase noise within that offset frequency interval.

Phase noise has a detrimental effect on the performance of analog-to-digital converters (ADCs), digital-to-analog converters (DACs), and signal input (RF) mixers. It lowers the achievable dynamic range of the converters and mixers, although they are affected in different ways.

Time Jitter

Phase noise is a frequency domain phenomenon. In the time domain, the same effect is exhibited as time jitter. When observing a sine wave, the time of successive zero crossings is seen to vary. In a square wave, the time jitter is seen as a displacement of the edges from their ideal (regular) times of occurrence. In both cases, the variations in timing from the ideal are the time jitter. Since these variations are random in nature, the time jitter is specified in units of seconds root mean square (rms) or 1 sigma of the Gaussian distribution.

Time jitter that occurs on a sampling clock for a DAC or an ADC decreases the SNR and dynamic range of the converter. A sampling clock with the lowest possible jitter provides the highest performance from a given converter.

Additive Phase Noise

Additive phase noise is the amount of phase noise attributable to the device or subsystem being measured. The phase noise of any external oscillators or clock sources is subtracted. This makes it possible to predict the degree to which the device impacts the total system phase noise when used in conjunction with the various oscillators and clock sources, each of which contribute their own phase noise to the total. In many cases, the phase noise of one element dominates the system phase noise.

Additive Time Jitter

Additive time jitter is the amount of time jitter attributable to the device or subsystem being measured. The time jitter of any external oscillators or clock sources is subtracted. This makes it possible to predict the degree to which the device impacts the total system time jitter when used in conjunction with the various oscillators and clock sources, each of which contribute their own time jitter to the total. In many cases, the time jitter of the external oscillators and clock sources dominates the system time jitter.

TYPICAL MODES OF OPERATION

PLL WITH EXTERNAL VCXO/VCO FOLLOWED BY CLOCK DISTRIBUTION

This is the most common operational mode for the AD9510. An external oscillator (shown as VCO/VCXO) is phase locked to a reference input frequency applied to REFIN. The loop filter is usually a passive design. A VCO or a VCXO can be used. The CLK2 input is connected internally to the feedback divider, N. The CLK2 input provides the feedback path for the PLL. If the VCO/VCXO frequency exceeds maximum frequency of the output or outputs being used, an appropriate divide ratio must be set in the corresponding divider or dividers in the Distribution Section. Save some power by shutting off unused functions and by powering down any unused clock channels (see the Register Map and Description section).

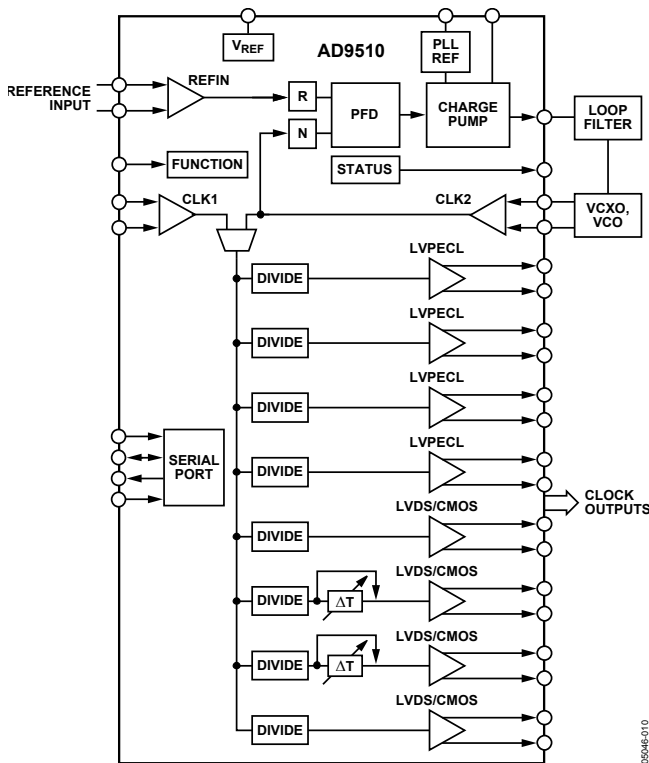

Figure 30. PLL and Clock Distribution Mode

05046-010

CLOCK DISTRIBUTION ONLY

It is possible to use only the distribution section whenever the PLL section is not needed. Save power by shutting off the PLL block, and by powering down any unused clock channels (see the Register Map and Description section).

In distribution mode, both the CLK1 and CLK2 inputs are available for distribution to outputs via a low jitter multiplexer (mux).

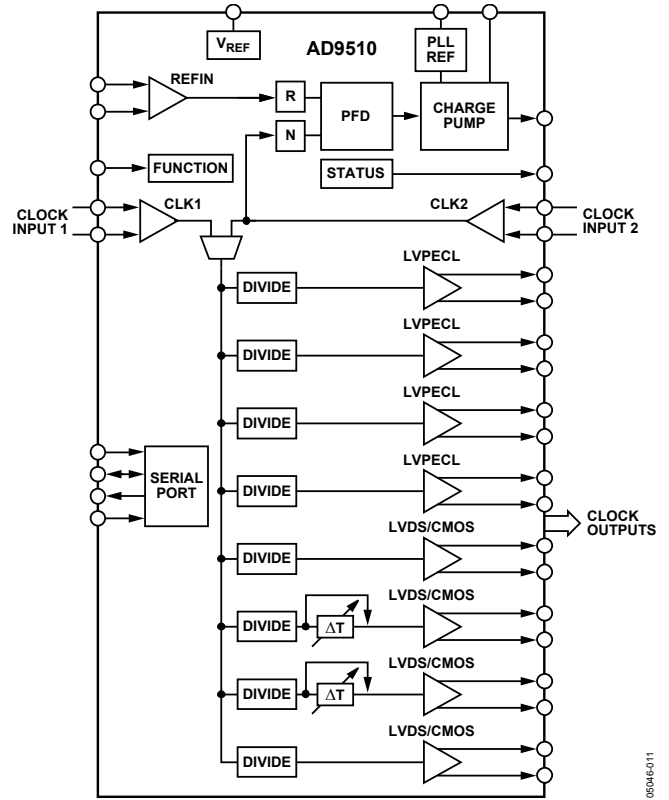

Figure 31. Clock Distribution Mode

05046-011

PLL WITH EXTERNAL VCO AND BAND-PASS FILTER FOLLOWED BY CLOCK DISTRIBUTION

An external band-pass filter (BPF) can be used to improve the phase noise and spurious characteristics of the PLL output. This option is most appropriate to optimize cost by choosing a less expensive VCO combined with a moderately priced filter. Note that the BPF is shown outside of the VCO-to-N divider path, with the BP filter outputs routed to CLK1. Save some power by shutting off unused functions, and by powering down any unused clock channels (see the Register Map and Description section).

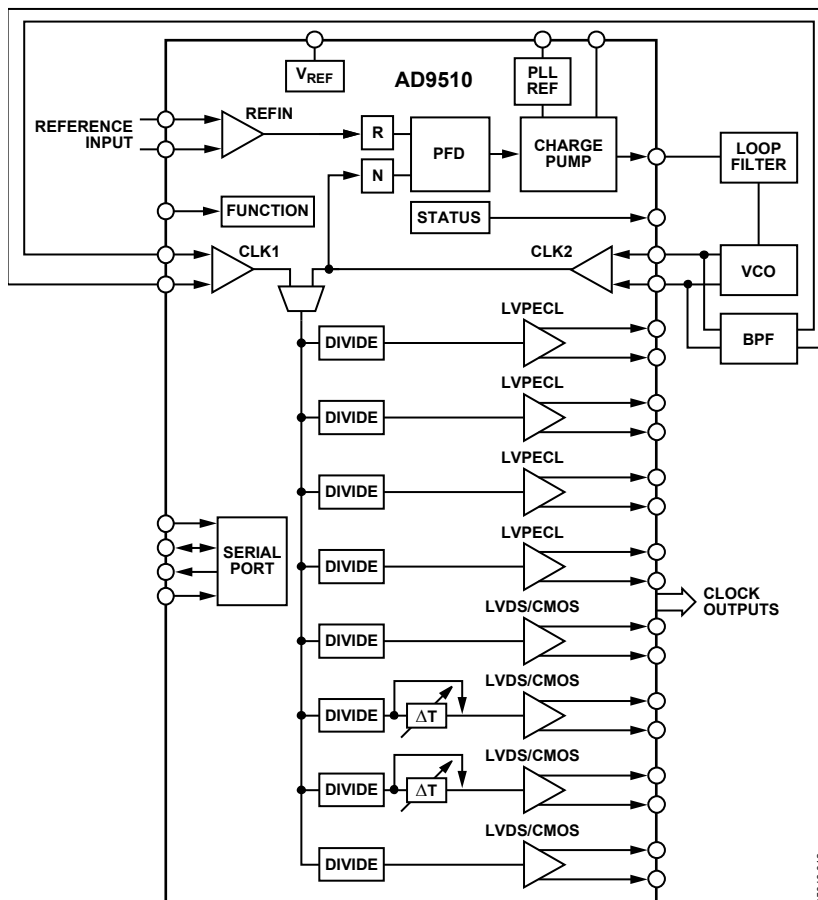

Figure 32. AD9510 with VCO and BPF Filter

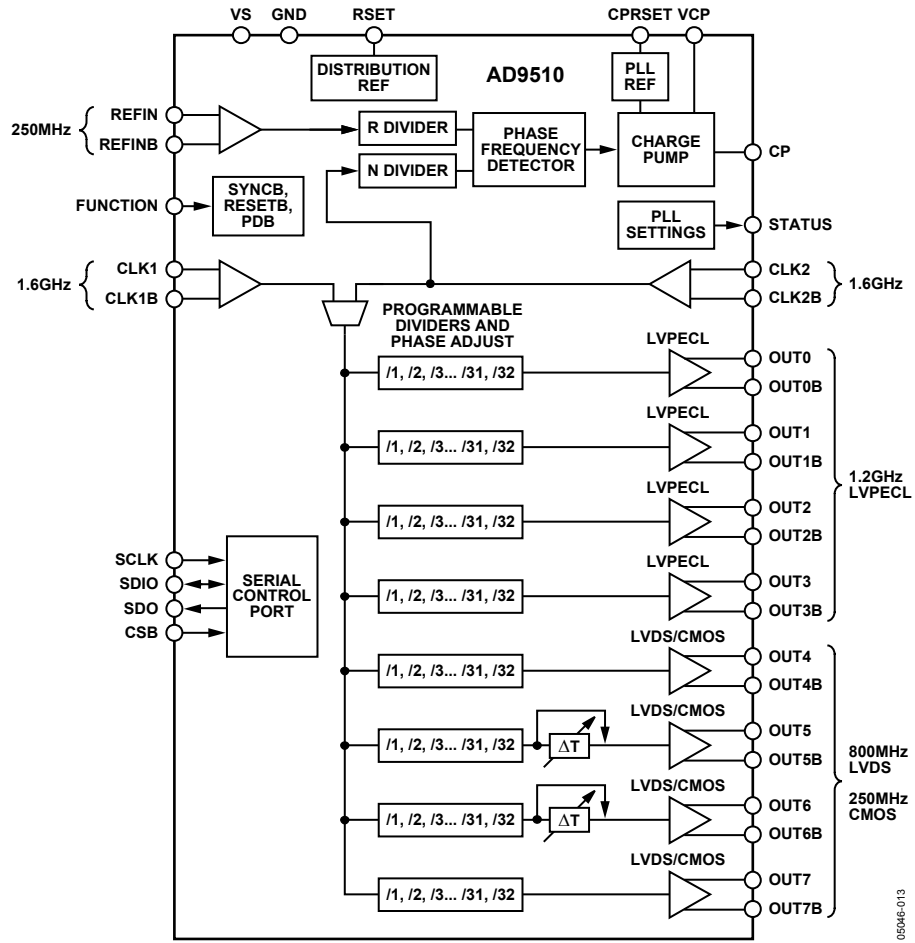

Figure 33. Functional Block Diagram Showing Maximum Frequencies

05046-013

FUNCTIONAL DESCRIPTION

OVERALL

Figure 33 shows a block diagram of the AD9510. The chip combines a programmable PLL core with a configurable clock distribution system. A complete PLL requires the addition of a suitable external VCO (or VCXO) and loop filter. This PLL can lock to a reference input signal and produce an output that is related to the input frequency by the ratio defined by the programmable R and N dividers. The PLL cleans up some jitter from the external reference signal, depending on the loop bandwidth and the phase noise performance of the VCO (VCXO).

The output from the VCO (VCXO) can be applied to the clock distribution section of the chip, where it can be divided by any integer value from 1 to 32. The duty cycle and relative phase of the outputs can be selected. There are four LVPECL outputs, (OUT0, OUT1, OUT2, and OUT3) and four outputs that can be either LVDS or CMOS level outputs (OUT4, OUT5, OUT6, and OUT7). Two of these outputs (OUT5 and OUT6) can also make use of a variable delay block.

Alternatively, the clock distribution section can be driven directly by an external clock signal, and the PLL can be powered off. Whenever the clock distribution section is used alone, there is no clock cleanup. The jitter of the input clock signal is passed along directly to the distribution section and may dominate at the clock outputs.

PLL SECTION

The AD9510 consists of a PLL section and a distribution section. If desired, the PLL section can be used separately from the distribution section.

The AD9510 has a complete PLL core on-chip, requiring only an external loop filter and VCO/VCXO. This PLL is based on the ADF4106, a PLL noted for its superb low phase noise performance. The operation of the AD9510 PLL is nearly identical to that of the ADF4106, offering an advantage to those with experience with the ADF series of PLLs. Differences include the addition of differential inputs at REFIN and CLK2, a different control register architecture. Also, the prescaler is changed to allow N as low as 1. The AD9510 PLL implements the digital lock detect feature somewhat differently than the ADF4106 does, offering improved functionality at higher PFD rates. See the Register Map Description section.

PLL Reference Input—REFIN

The REFIN/REFINB pins can be driven by either a differential or a single-ended signal. These pins are internally self-biased so that they can be ac-coupled via capacitors. It is possible to dc-couple to these inputs. If REFIN is driven single-ended, decouple the unused side (REFINB) via a suitable capacitor to a quiet ground. Figure 34 shows the equivalent circuit of REFIN.

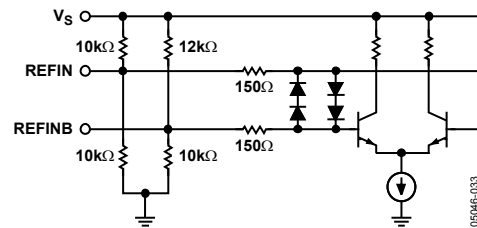

Figure 34. REFIN Equivalent Circuit

VCO/VCXO Clock Input—CLK2

The CLK2 differential input is used to connect an external VCO or VCXO to the PLL. Only the CLK2 input port has a connection to the PLL N divider. This input can receive up to 1.6 GHz. These inputs are internally self-biased and must be ac-coupled via capacitors.

Alternatively, CLK2 can be used as an input to the distribution section. This is accomplished by setting Register 0x45[0] = 0b. The default condition is for CLK1 to feed the distribution section.

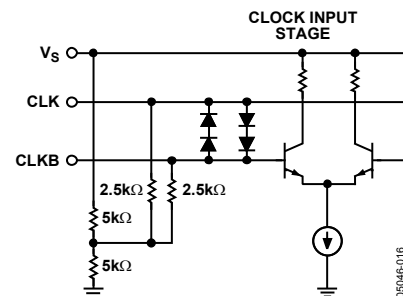

Figure 35. CLK1, CLK2 Equivalent Input Circuit

PLL Reference Divider—R

The REFIN/REFINB inputs are routed to reference divider, R, which is a 14-bit counter. R can be programmed to any value from 1 to 16383 (a value of 0 results in a divide by 1) via its control register (Register 0x0B[5:0], Register 0x0C[7:0]). The output of the R divider goes to one of the phase frequency detector inputs. Do not exceed the maximum allowable frequency into the phase frequency detector (PFD). This means that the REFIN frequency divided by R must be less than the maximum allowable PFD frequency. See Figure 34.

VCO/VCXO Feedback Divider—N (P, A, B)

The N divider is a combination of a prescaler, P (3 bits), and two counters, A (6 bits) and B (13 bits). Although the PLL of the AD9510 is similar to the ADF4106, the AD9510 has a redesigned prescaler that allows lower values of N. The prescaler has both a dual modulus (DM) and a fixed divide (FD) mode. The AD9510 prescaler modes are shown in Table 15.

Table 15. PLL Prescaler Modes

Mode (FD = Fixed Divide, DM = Dual Modulus)	Value in Register 0x0A[4:2]	Divide By
FD	000	1
FD	001	2
P = 2 DM	010	P/P + 1 = 2/3
P = 4 DM	011	P/P + 1 = 4/5
P = 8 DM	100	P/P + 1 = 8/9
P = 16 DM	101	P/P + 1 = 16/17
P = 32 DM	110	P/P + 1 = 32/33
FD	111	3

When using the prescaler in FD mode, the A counter is not used, and the B counter may need to be bypassed. The DM prescaler modes set some upper limits on the frequency, which can be applied to CLK2. See Table 16.

Table 16. Frequency Limits of Each Prescaler Mode

Mode (DM = Dual Modulus)	CLK2
P = 2 DM (2/3)	<600 MHz
P = 4 DM (4/5)	<1000 MHz
P = 8 DM (8/9)	<1600 MHz
P = 16 DM	<1600 MHz
P = 32 DM	<1600 MHz

Table 17. P, A, B, R—Smallest Values for N

f _{REF}	R	P	A	B	N	f _{VCO}	Mode	Notes
10	1	1	X	1	1	10	FD	P = 1, B = 1 (Bypassed)
10	1	2	X	1	2	20	FD	P = 2, B = 1 (Bypassed)
10	1	1	X	3	3	30	FD	P = 1, B = 3
10	1	1	X	4	4	40	FD	P = 1, B = 4
10	1	1	X	5	5	50	FD	P = 1, B = 5
10	1	2	X	3	6	60	FD	P = 2, B = 3
10	1	2	0	3	6	60	DM	P/P + 1 = 2/3, A = 0, B = 3
10	1	2	1	3	7	70	DM	P/P + 1 = 2/3, A = 1, B = 3
10	1	2	2	3	8	80	DM	P/P + 1 = 2/3, A = 2, B = 3
10	1	2	1	4	9	90	DM	P/P + 1 = 2/3, A = 1, B = 4
10	1	2	X	5	10	100	FD	P = 2, B = 5
10	1	2	0	5	10	100	DM	P/P + 1 = 2/3, A = 0, B = 5
10	1	2	1	5	11	110	DM	P/P + 1 = 2/3, A = 1, B = 5
10	1	2	X	6	12	120	FD	P = 2, B = 6
10	1	2	0	6	12	120	DM	P/P + 1 = 2/3, A = 0, B = 6
10	1	4	0	3	12	120	DM	P/P + 1 = 4/5, A = 0, B = 3
10	1	4	1	3	13	130	DM	P/P + 1 = 4/5, A = 1, B = 3

A and B Counters

The AD9510 B counter has a bypass mode (B = 1), which is not available on the ADF4106. The B counter bypass mode is valid only when using the prescaler in FD mode. The B counter is bypassed by writing 1 to the B counter bypass bit (Register 0x0A[6] = 1b). The valid range of the B counter is 3 to 8191. The default after a reset is 0, which is invalid.

Note that the A counter is not used when the prescaler is in FD mode.

Note also that the A/B counters have their own reset bit, which is primarily intended for testing. The A and B counters can also be reset using the shared reset bit of the R, A, and B counters (Register 0x09[0]).

Determining Values for P, A, B, and R

When operating the AD9510 in a dual-modulus mode, the input reference frequency, f_{REF}, is related to the VCO output frequency, f_{VCO}.

$$f_{VCO} = (f_{REF}/R) \times (PB + A) = f_{REF} \times N/R$$

When operating the prescaler in fixed divide mode, the A counter is not used and the equation simplifies to

$$f_{VCO} = (f_{REF}/R) \times (PB) = f_{REF} \times N/R$$

By using combinations of dual modulus and fixed divide modes, the AD9510 can achieve values of N all the way down to N = 1. Table 17 shows how a 10 MHz reference input can be locked to any integer multiple of N. Note that the same value of N can be derived in different ways, as illustrated by N = 12.

Phase Frequency Detector (PFD) and Charge Pump

The PFD takes inputs from the R counter and the N counter ($N = BP + A$) and produces an output proportional to the phase and frequency difference between them. Figure 36 is a simplified schematic. The PFD includes a programmable delay element that controls the width of the antibacklash pulse. This pulse ensures that there is no dead zone in the PFD transfer function and minimizes phase noise and reference spurs. Two bits in Register 0x0D[1:0] control the width of the pulse.

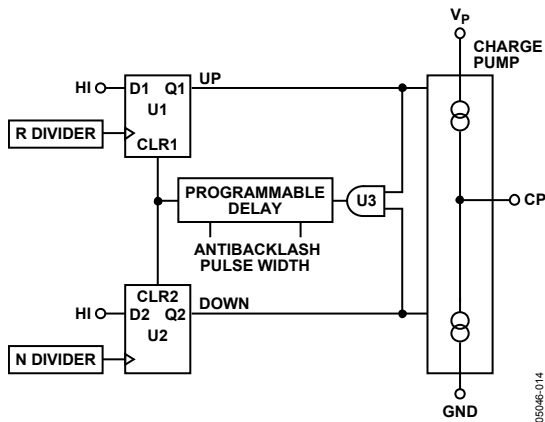

Figure 36. PFD Simplified Schematic and Timing (In Lock)

Antibacklash Pulse

The PLL features a programmable antibacklash pulse width that is set by the value in Register 0x0D[1:0]. The default antibacklash pulse width is 1.3 ns (Register 0x0D[1:0] = 00b) and normally does not need to be changed. The antibacklash pulse

eliminates the dead zone around the phase-locked condition and thereby reduces the potential for certain spurs that can be impressed on the VCO signal.

STATUS Pin

The output multiplexer on the AD9510 allows access to various signals and internal points on the chip at the STATUS pin. Figure 37 shows a block diagram of the STATUS pin section. The function of the STATUS pin is controlled by Register 0x8[5:2].

PLL Digital Lock Detect

The STATUS pin can display two types of PLL lock detect: digital (DLD) and analog (ALD). Whenever digital lock detect is desired, the STATUS pin provides a CMOS level signal, which can be active high or active low.

The digital lock detect has one of two time windows, as selected by Register 0x0D[5]. The default (Register 0x0D[5] = 0b) requires the signal edges on the inputs to the PFD to be coincident within 9.5 ns to set the DLD true, which then must separate by at least 15 ns to give DLD = false.

The other setting (Register 0x0D[5] = 1) makes these coincidence times 3.5 ns for DLD = true and 7 ns for DLD = false.

The DLD can be disabled by writing 1 to Register 0x0D[6].

If the signal at REFIN goes away while DLD is true, the DLD does not necessarily indicate loss of lock. See the Loss of Reference section for more information.

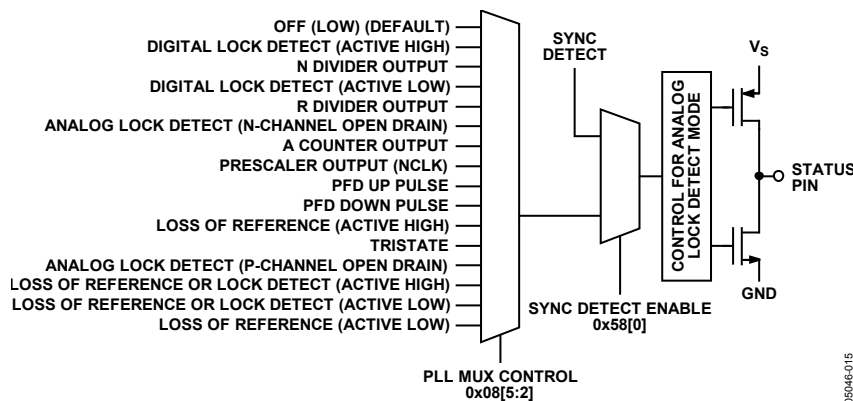

Figure 37. STATUS Pin Circuit CLK1 Clock Input

PLL Analog Lock Detect

An analog lock detect (ALD) signal can be selected. When ALD is selected, the signal at the STATUS pin is either an open-drain P-channel (Register 0x08[5:2] = 1100) or an open-drain N-channel (Register 0x08[5:2] = 0101b).

The analog lock detect signal is true (relative to the selected mode) with brief false pulses. These false pulses shorten as the inputs to the PFD are nearer to coincidence and longer as they are further from coincidence.

To extract a usable analog lock detect signal, an external resistor-capacitor (RC) network is required to provide an analog filter with the appropriate RC constant to allow for the discrimination of a lock condition by an external voltage comparator. A 1 kΩ resistor in parallel with a small capacitance usually fulfills this requirement. However, some experimentation may be required to obtain the desired operation.

The analog lock detect function may introduce some spurious energy into the clock outputs. It is prudent to limit the use of the ALD when the best possible jitter/phase noise performance is required on the clock outputs.

Loss of Reference

The AD9510 PLL can warn of a loss of reference signal at REFIN. The loss of reference monitor internally sets a flag called LREF. Externally, this signal can be observed in several ways on the STATUS pin, depending on the PLL MUX control settings in Register 0x08[5:2]. The LREF alone can be observed as an active high signal by setting Register 0x08[5:2] = [1010] or as an active low signal by setting Register 0x08[5:2] = [1111].

The loss of reference circuit is clocked by the signal from the VCO, which means that there must be a VCO signal present to detect a loss of reference.

The digital lock detect (DLD) block of the AD9510 requires a PLL reference signal to be present in order for the digital lock detect output to be valid. It is possible to have a digital lock detect indication (DLD = true) that remains true even after a loss of reference signal. For this reason, the digital lock detect signal alone cannot be relied upon if the reference has been lost. To combine the DLD and the LREF into a single signal at the STATUS pin, set Register 0x08[5:2] = [1101] to obtain a signal that is the logical OR of the loss of lock (inverse of DLD) and the loss of reference (LREF) active high. If an active low version of this same signal is desired, set Register 0x08[5:2] = [1110].

The reference monitor is enabled only after the DLD signal is high for the number of PFD cycles set by the value in Register 0x07[6:5]. This delay is measured in PFD cycles. The delay ranges from 3 PFD cycles (default) to 24 PFD cycles. When the reference goes away, LREF goes true and the charge pump goes into tristate.

User intervention is required to take the part out of this state. First, Register 0x07[2] = 0b must be written to disable the loss of reference circuit, taking the charge pump out of tristate and causing LREF to go false. A second write of Register 0x07[2] = 1 is required to reenable the loss of reference circuit.

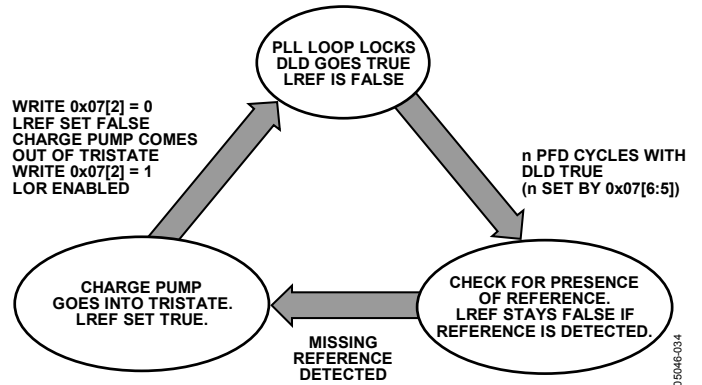

Figure 38. Loss of Reference Sequence of Events

05046-034

FUNCTION PIN

The FUNCTION pin (16) has three functions that are selected by the value in Register 0x58[6:5]. This pin is internally pulled down by a 30 kΩ resistor. If this pin is left unconnected, the part is in reset by default. To avoid this, connect this pin to V_s with a 1 kΩ resistor.

RESETB: Register 0x58[6:5] = 00b (Default)

In its default mode, the FUNCTION pin acts as RESETB, which generates an asynchronous reset or hard reset when pulled low. The resulting reset writes the default values into the serial control port buffer registers as well as loading them into the chip control registers. When the RESETB signal goes high again, a synchronous sync is issued (see the SYNCB: Register 0x58[6:5] = 01b section) and the AD9510 resumes operation according to the default values of the registers.

SYNCB: Register 0x58[6:5] = 01b

Using the FUNCTION pin causes a synchronization or alignment of phase among the various clock outputs. The synchronization applies only to clock outputs that

- Are not powered down
- The divider is not masked (no sync = 0b)
- Are not bypassed (bypass = 0b)

SYNCB is level and rising edge sensitive. When SYNCB is low, the set of affected outputs are held in a predetermined state, defined by the start high bit of each divider. On a rising edge, the dividers begin after a predefined number of fast clock cycles (fast clock is the selected clock input, CLK1 or CLK2) as determined by the values in the phase offset bits of the divider.

The SYNCB application of the FUNCTION pin is always active, regardless of whether the pin is also assigned to perform reset or power-down. When the SYNCB function is selected, the FUNCTION pin does not act as either RESETB or PDB.

PDB: Register 0x58[6:5] = 11b

The FUNCTION pin can also be programmed to work as an asynchronous full power-down, PDB. Even in this full power-down mode, there is still some residual V_s current because some on-chip references continue to operate. In PDB mode, the FUNCTION pin is active low. The chip remains in a power-down state until PDB is returned to logic high. The chip returns to the settings programmed prior to the power-down.

See the Chip Power-Down or Sleep Mode—PDB section for more details on what occurs during a PDB initiated power-down.

DISTRIBUTION SECTION

As previously mentioned, the AD9510 is partitioned into two operational sections: PLL and distribution. The PLL Section is discussed previously in this data sheet. If desired, the distribution section can be used separately from the PLL section.

CLK1 AND CLK2 CLOCK INPUTS

Either CLK1 or CLK2 can be selected as the input to the distribution section. The CLK1 input can be connected to drive the distribution section only. CLK1 is selected as the source for the distribution section by setting Register 0x45[0] = 1. This is the power-up default state.

CLK1 and CLK2 work for inputs up to 1600 MHz. A higher input slew rate improves the jitter performance. The input level must be between approximately 150 mV p-p to no more than 2 V p-p. Anything greater may result in turning on the protection diodes on the input pins, which may degrade the jitter performance.

See Figure 35 for the CLK1 and CLK2 equivalent input circuit. These inputs are fully differential and self-biased. The signal must be ac-coupled using capacitors. If a single-ended input must be used, this can be accommodated by ac-coupling to one side of the differential input only. Bypass the other side of the input to a quiet ac ground by a capacitor.

Power down the unselected clock input (CLK1 or CLK2) to eliminate any possibility of unwanted crosstalk between the selected clock input and the unselected clock input.

DIVIDERS

Each of the eight clock outputs of the AD9510 has its own divider. The divider can be bypassed to obtain an output at the same frequency as the input (1×). When a divider is bypassed, it is powered down to save power.

All integer divide ratios from 1 to 32 can be selected. A divide ratio of 1 is selected by bypassing the divider.

Each divider can be configured for divide ratio, phase, and duty cycle. The phase and duty cycle values that can be selected depend on the divide ratio that is chosen.

Setting the Divide Ratio

The divide ratio is determined by the values written via the serial control port (SCP) to the registers that control each individual output, OUT0 to OUT7. These are the even numbered registers beginning at Register 0x48 and going through Register 0x56. Each of these registers is divided into bits that control the number of clock cycles that the divider output stays high (HIGH_CYCLES[3:0]) and the number of clock cycles that the divider output stays low (LOW_CYCLES[7:4]). Each value is 4 bits and has the range of 0 to 15.

The divide ratio is set by

$$\text{Divide Ratio} = (\text{HIGH_CYCLES} + 1) + (\text{LOW_CYCLES} + 1)$$

Example 1:

Set the Divide Ratio = 2

$$HIGH_CYCLES = 0$$

$$LOW_CYCLES = 0$$

$$Divide\ Ratio = (0 + 1) + (0 + 1) = 2$$

Example 2:

Set Divide Ratio = 8

$$HIGH_CYCLES = 3$$

$$LOW_CYCLES = 3$$

$$Divide\ Ratio = (3 + 1) + (3 + 1) = 8$$

Note that a Divide Ratio of 8 can also be obtained by setting:

$$HIGH_CYCLES = 2$$

$$LOW_CYCLES = 4$$

$$Divide\ Ratio = (2 + 1) + (4 + 1) = 8$$

Although the second set of settings produces the same divide ratio, the resulting duty cycle is not the same.

Setting the Duty Cycle

The duty cycle and the divide ratio are related. Different divide ratios have different duty cycle options. For example, if Divide Ratio = 2, the only duty cycle possible is 50%. If the Divide Ratio = 4, the duty cycle can be 25%, 50%, or 75%.

The duty cycle is set by

$$Duty\ Cycle = (HIGH_CYCLES + 1) / ((HIGH_CYCLES + 1) + (LOW_CYCLES + 1))$$

See Table 18 for the values for the available duty cycles for each divide ratio.

Table 18. Duty Cycle and Divide Ratio

Divide Ratio	Duty Cycle (%)	Address 0x48 to Address 0x56	
		LO[7:4]	HI[3:0]
2	50	0	0
3	67	0	1
3	33	1	0
4	50	1	1
4	75	0	2
4	25	2	0
5	60	1	2
5	40	2	1
5	80	0	3
5	20	3	0
6	50	2	2
6	67	1	3
6	33	3	1
6	83	0	4
6	17	4	0
7	57	2	3
7	43	3	2
7	71	1	4
7	29	4	1
7	86	0	5
7	14	5	0
8	50	3	3
8	63	2	4
8	38	4	2
8	75	1	5
8	25	5	1
8	88	0	6
8	13	6	0
9	56	3	4
9	44	4	3
9	67	2	5

Divide Ratio	Duty Cycle (%)	Address 0x48 to Address 0x56	
		LO[7:4]	HI[3:0]
9	33	5	2
9	78	1	6
9	22	6	1
9	89	0	7
9	11	7	0
10	50	4	4
10	60	3	5
10	40	5	3
10	70	2	6
10	30	6	2
10	80	1	7
10	20	7	1
10	90	0	8
10	10	8	0
11	55	4	5
11	45	5	4
11	64	3	6
11	36	6	3
11	73	2	7
11	27	7	2
11	82	1	8
11	18	8	1
11	91	0	9
11	9	9	0
12	50	5	5
12	58	4	6
12	42	6	4
12	67	3	7
12	33	7	3
12	75	2	8
12	25	8	2

Divide Ratio	Duty Cycle (%)	Address 0x48 to Address 0x56		Divide Ratio	Duty Cycle (%)	Address 0x48 to Address 0x56	
		LO[7:4]	HI[3:0]			LO[7:4]	HI[3:0]
12	83	1	9	16	75	3	B
12	17	9	1	16	25	B	3
12	92	0	A	16	81	2	C
12	8	A	0	16	19	C	2
13	54	5	6	16	88	1	D
13	46	6	5	16	13	D	1
13	62	4	7	16	94	0	E
13	38	7	4	16	6	E	0
13	69	3	8	17	53	7	8
13	31	8	3	17	47	8	7
13	77	2	9	17	59	6	9
13	23	9	2	17	41	9	6
13	85	1	A	17	65	5	A
13	15	A	1	17	35	A	5
13	92	0	B	17	71	4	B
13	8	B	0	17	29	B	4
14	50	6	6	17	76	3	C
14	57	5	7	17	24	C	3
14	43	7	5	17	82	2	D
14	64	4	8	17	18	D	2
14	36	8	4	17	88	1	E
14	71	3	9	17	12	E	1
14	29	9	3	17	94	0	F
14	79	2	A	17	6	F	0
14	21	A	2	18	50	8	8
14	86	1	B	18	56	7	9
14	14	B	1	18	44	9	7
14	93	0	C	18	61	6	A
14	7	C	0	18	39	A	6
15	53	6	7	18	67	5	B
15	47	7	6	18	33	B	5
15	60	5	8	18	72	4	C
15	40	8	5	18	28	C	4
15	67	4	9	18	78	3	D
15	33	9	4	18	22	D	3
15	73	3	A	18	83	2	E
15	27	A	3	18	17	E	2
15	80	2	B	18	89	1	F
15	20	B	2	18	11	F	1
15	87	1	C	19	53	8	9
15	13	C	1	19	47	9	8
15	93	0	D	19	58	7	A
15	7	D	0	19	42	A	7
16	50	7	7	19	63	6	B
16	56	6	8	19	37	B	6
16	44	8	6	19	68	5	C
16	63	5	9	19	32	C	5
16	38	9	5	19	74	4	D
16	69	4	A	19	26	D	4
16	31	A	4	19	79	3	E

Divide Ratio	Duty Cycle (%)	Address 0x48 to Address 0x56	
		LO[7:4]	HI[3:0]
19	21	E	3
19	84	2	F
19	16	F	2
20	50	9	9
20	55	8	A
20	45	A	8
20	60	7	B
20	40	B	7
20	65	6	C
20	35	C	6
20	70	5	D
20	30	D	5
20	75	4	E
20	25	E	4
20	80	3	F
20	20	F	3
21	52	9	A
21	48	A	9
21	57	8	B
21	43	B	8
21	62	7	C
21	38	C	7
21	67	6	D
21	33	D	6
21	71	5	E
21	29	E	5
21	76	4	F
21	24	F	4
22	50	A	A
22	55	9	B
22	45	B	9
22	59	8	C
22	41	C	8
22	64	7	D
22	36	D	7
22	68	6	E
22	32	E	6
22	73	5	F
22	27	F	5
23	52	A	B
23	48	B	A
23	57	9	C
23	43	C	9
23	61	8	D
23	39	D	8
23	65	7	E
23	35	E	7
23	70	6	F

Divide Ratio	Duty Cycle (%)	Address 0x48 to Address 0x56	
		LO[7:4]	HI[3:0]
23	30	F	6
24	50	B	B
24	54	A	C
24	46	C	A
24	58	9	D
24	42	D	9
24	63	8	E
24	38	E	8
24	67	7	F
24	33	F	7
25	52	B	C
25	48	C	B
25	56	A	D
25	44	D	A
25	60	9	E
25	40	E	9
25	64	8	F
25	36	F	8
26	50	C	C
26	54	B	D
26	46	D	B
26	58	A	E
26	42	E	A
26	62	9	F
26	38	F	9
27	52	C	D
27	48	D	C
27	56	B	E
27	44	E	B
27	59	A	F
27	41	F	A
28	50	D	D
28	54	C	E
28	46	E	C
28	57	B	F
28	43	F	B
29	52	D	E
29	48	E	D
29	55	C	F
29	45	F	C
30	50	E	E
30	53	D	F
30	47	F	D
31	52	E	F
31	48	F	E
32	50	F	F

Divider Phase Offset

The phase of each output can be selected, depending on the divide ratio chosen. This is selected by writing the appropriate values to the registers which set the phase and start high/low bit for each output. These are the odd numbered registers from Register 0x49 to Register 0x57. Each divider has a 4-bit phase offset [3:0] and a start high or low bit [4].

Following a sync pulse, the phase offset word determines how many fast clock (CLK1 or CLK2) cycles to wait before initiating a clock output edge. The Start H/L bit determines if the divider output starts low or high. By giving each divider a different phase offset, output-to-output delays can be set in increments of the fast clock period, t_{CLK} .

Figure 39 shows four dividers, each set for DIV = 4, 50% duty cycle. By incrementing the phase offset from 0 to 3, each output is offset from the initial edge by a multiple of t_{CLK} .

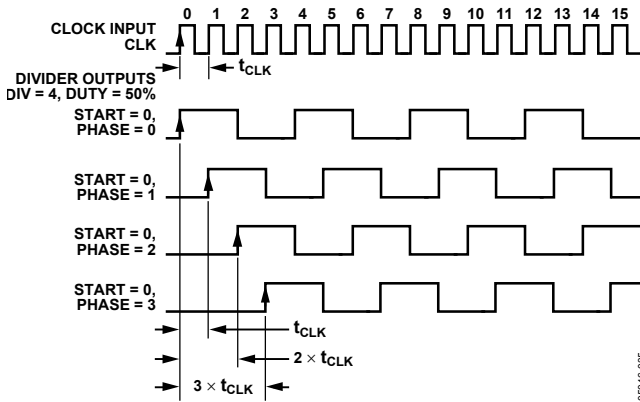

Figure 39. Phase Offset—All Dividers Set for DIV = 4, Phase Set from 0 to 3

For example:

- CLK1 = 491.52 MHz
- $t_{CLK1} = 1/491.52 = 2.0345$ ns
- For DIV = 4
- Phase Offset 0 = 0 ns
- Phase Offset 1 = 2.0345 ns
- Phase Offset 2 = 4.069 ns
- Phase Offset 3 = 6.104 ns

The four outputs can also be described as:

- OUT1 = 0°
- OUT2 = 90°
- OUT3 = 180°
- OUT4 = 270°

Setting the phase offset to Phase = 4 results in the same relative phase as the first channel, Phase = 0° or 360°.

In general, by combining the 4-bit phase offset and the Start H/L bit, there are 32 possible phase offset states (see Table 19).

Table 19. Phase Offset—Start H/L Bit

Phase Offset (Fast Clock Rising Edges)	Address 0x49 to Address 0x57	
	Phase Offset[3:0]	Start H/L[4]
0	0	0
1	1	0
2	2	0
3	3	0
4	4	0
5	5	0
6	6	0
7	7	0
8	8	0
9	9	0
10	10	0
11	11	0
12	12	0
13	13	0
14	14	0
15	15	0
16	0	1
17	1	1
18	2	1
19	3	1
20	4	1
21	5	1
22	6	1
23	7	1
24	8	1
25	9	1
26	10	1
27	11	1
28	12	1
29	13	1
30	14	1
31	15	1

The resolution of the phase offset is set by the fast clock period (t_{CLK}) at CLK1 or CLK2. As a result, every divide ratio does not have 32 unique phase offsets available. For any divide ratio, the number of unique phase offsets is numerically equal to the divide ratio (see Table 19):

- DIV = 4
Unique Phase Offsets Are Phase = 0, 1, 2, 3
- DIV = 7
Unique Phase Offsets Are Phase = 0, 1, 2, 3, 4, 5, 6
- DIV = 18
Unique Phase Offsets Are Phase = 0, 1, 2, 3, 4, 5, 6, 7, 8, 9, 10, 11, 12, 13, 14, 15, 16, 17

Phase offsets can be related to degrees by calculating the phase step for a particular divide ratio:

$$\text{Phase Step} = 360^\circ / (\text{Divide Ratio}) = 360^\circ / \text{DIV}$$

Using some of the same examples,

$$\text{DIV} = 4$$

$$\text{Phase Step} = 360^\circ / 4 = 90^\circ$$

Unique Phase Offsets in Degrees Are Phase = 0°, 90°, 180°, 270°

$$\text{DIV} = 7$$

$$\text{Phase Step} = 360^\circ / 7 = 51.43^\circ$$

Unique Phase Offsets in Degrees Are Phase = 0°, 51.43°, 102.86°, 154.29°, 205.71°, 257.15°, 308.57°

DELAY BLOCK

OUT5 and OUT6 (LVDS/CMOS) include an analog delay element that can be programmed (from Register 0x34 to Register 0x3A) to give variable time delays (Δt) in the clock signal passing through that output.

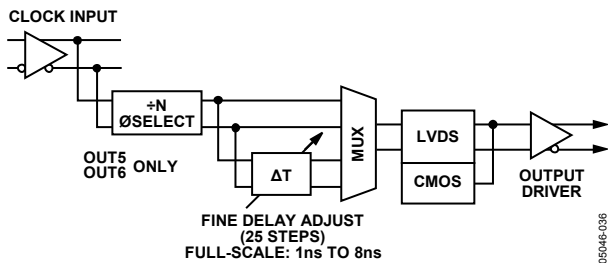

Figure 40. Analog Delay (OUT5 and OUT6)

The amount of delay that can be used is determined by the frequency of the clock being delayed. The amount of delay can approach one-half cycle of the clock period. For example, for a 10 MHz clock, the delay can extend to the full 8 ns maximum of which the delay element is capable. However, for a 100 MHz clock (with 50% duty cycle), the maximum delay is less than 5 ns (or half of the period).

OUT5 and OUT6 allow a full-scale delay in the range 1 ns to 8 ns. The full-scale delay is selected by choosing a combination of ramp current and the number of capacitors by writing the appropriate values into Register 0x35 and Register 0x39. There are 25 fine delay settings (Register 0x36 and Register 0x3A = 00000b to 11000b) for each full scale, set by Register 0x36 and Register 0x3A.

This path adds some jitter greater than that specified for the nondelay outputs. Therefore, use the delay function primarily for clocking digital chips, such as FPGA, ASIC, DUC, and DDC, rather than for data converters. The jitter is higher for long full scales (~8 ns). This is because the delay block uses a ramp and trip points to create the variable delay. A longer ramp means more noise can be introduced.

Calculating the Delay

The following values and equations are used to calculate the delay of the delay block.

Value of Ramp Current Control Bits (Register 0x35 or Register 0x39 [2:0]) = I_{RAMP_BITS}

$$I_{RAMP} (\mu A) = 200 \times (I_{RAMP_BITS} + 1)$$

No. of Caps = No. of 0s + 1 in Ramp Control Capacitor (Register 0x35 or Register 0x39 [5:3]), that is, 101 = 1 + 1 = 2; 110 = 2; 100 = 2 + 1 = 3; 001 = 2 + 1 = 3; 111 = 0 + 1 = 1)

$$DELAY_RANGE (ns) = 200 \times ((\text{No. of Caps} + 3) / (I_{RAMP})) \times 1.3286$$

$$Offset (ns) = 0.34 + (1600 - I_{RAMP}) \times 10^{-4} + \left(\frac{\text{No. of Caps} - 1}{I_{RAMP}} \right) \times 6$$

$$DELAY_FULL_SCALE (ns) = DELAY_RANGE \times (24/31) + Offset$$

FINE_ADJ = Value of Delay Fine Adjust (Register 0x36 or Register 0x3A[5:1]), that is, 11000 = 24

$$Delay (ns) = Offset + DELAY_RANGE \times FINE_ADJ \times (1/31)$$

OUTPUTS

The AD9510 offers three different output level choices: LVPECL, LVDS, and CMOS. OUT0 to OUT3 are LVPECL only. OUT4 to OUT7 can be selected as either LVDS or CMOS. Each output can be enabled or turned off as needed to save power.

The simplified equivalent circuit of the LVPECL outputs is shown in Figure 41.

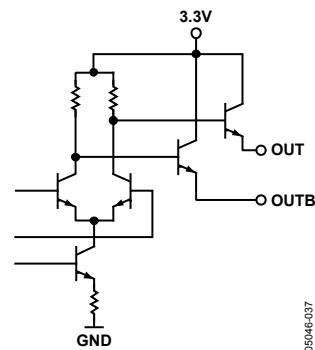

Figure 41. LVPECL Output Simplified Equivalent Circuit

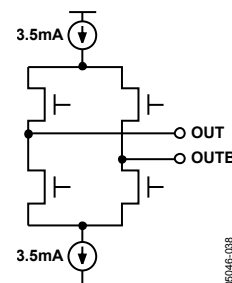

Figure 42. LVDS Output Simplified Equivalent Circuit

POWER-DOWN MODES

Chip Power-Down or Sleep Mode—PDB

The PDB chip power-down turns off most of the functions and currents in the AD9510. When the PDB mode is enabled, a chip power-down is activated by taking the FUNCTION pin to a logic low level. The chip remains in this power-down state until PDB is brought back to logic high. When woken up, the AD9510 returns to the settings programmed into its registers prior to the power-down, unless the registers are changed by new programming while the PDB mode is active.

The PDB power-down mode shuts down the currents on the chip, except the bias current necessary to maintain the LVPECL outputs in a safe shutdown mode. This is needed to protect the LVPECL output circuitry from damage that can be caused by certain termination and load configurations when tristated. Because this is not a complete power-down, it is also called sleep mode.

When the AD9510 is in a PDB power-down or sleep mode, the chip is in the following state:

- The PLL is off (asynchronous power-down).
- All clocks and sync circuits are off.
- All dividers are off.
- All LVDS/CMOS outputs are off.
- All LVPECL outputs are in safe off mode.
- The serial control port is active, and the chip responds to commands.

If the AD9510 clock outputs must be synchronized to each other, a SYNC (see the Single-Chip Synchronization section) is required upon exiting power-down mode.

PLL Power-Down

The PLL section of the AD9510 can be selectively powered down. There are three PLL power-down modes, set by the values in Register 0x0A[1:0], as shown in Table 20.

Table 20. Register 0x0A: PLL Power-Down

[1]	[0]	Mode
0	0	Normal Operation
0	1	Asynchronous Power-Down
1	0	Normal Operation
1	1	Synchronous Power-Down

In asynchronous power-down mode, the device powers down as soon as the registers are updated.

In synchronous power-down mode, the PLL power-down is gated by the charge pump to prevent unwanted frequency jumps. The device goes into power-down on the occurrence of the next charge pump event after the registers are updated.

Distribution Power-Down

The distribution section can be powered down by writing to Register 0x58[3] = 1. This turns off the bias to the distribution section. If the LVPECL power-down mode is normal operation

[00], it is possible for a low impedance load on that LVPECL output to draw significant current during this power-down. If the LVPECL power-down mode is set to [11], the LVPECL output is not protected from reverse bias and can be damaged under certain termination conditions.

When combined with the PLL power-down, this mode results in the lowest possible power-down current for the AD9510.

Individual Clock Output Power-Down

Any of the eight clock distribution outputs can be powered down individually by writing to the appropriate registers via the SCP. The register map details the individual power-down settings for each output. The LVDS/CMOS outputs can be powered down, regardless of their output load configuration.

The LVPECL outputs have multiple power-down modes (see Register Address 3C, Register Address 3D, Register Address 3E, and Register Address 3F in Table 25). These give some flexibility in dealing with various output termination conditions. When the mode is set to [10], the LVPECL output is protected from reverse bias to $2 V_{BE} + 1 V$. If the mode is set to [11], the LVPECL output is not protected from reverse bias and can be damaged under certain termination conditions. This setting also affects the operation when the distribution block is powered down with Register 0x58[3] = 1b (see the Distribution Power-Down section).

Individual Circuit Block Power-Down

Many of the AD9510 circuit blocks (CLK1, CLK2, REFIN, and so on) can be powered down individually. This gives flexibility in configuring the part for power savings whenever certain chip functions are not needed.

RESET MODES

The AD9510 has several ways to force the chip into a reset condition.

Power-On Reset—Start-Up Conditions when V_S is Applied

A power-on reset (POR) is issued when the V_S power supply is turned on. This initializes the chip to the power-on conditions that are determined by the default register settings. These are indicated in the default value column of Table 24.

Asynchronous Reset via the FUNCTION Pin

As mentioned in the FUNCTION Pin section, a hard reset, RESETB: Register 0x58[6:5] = 00b (Default), restores the chip to the default settings.

Soft Reset via the Serial Port

The serial control port allows a soft reset by writing to Register 0x00[5] = 1b. When this bit is set, the chip executes a soft reset. This restores the default values to the internal registers, except for Register 0x00 itself.

This bit is not self-clearing. The bit must be written to Register 0x00[5] = 0b in order for the operation of the part to continue.

SINGLE-CHIP SYNCHRONIZATION

SYNCB—Hardware SYNC

The AD9510 clocks can be synchronized to each other at any time. The outputs of the clocks are forced into a known state with respect to each other and then allowed to continue clocking from that state in synchronicity. Before a synchronization is done, the FUNCTION Pin must be set to act as the SYNCB: Register 0x58[6:5] = 01b input (Register 0x58[6:5] = 01b). Synchronization is done by forcing the FUNCTION pin low, creating a SYNCB signal and then releasing it.

See the SYNCB: Register 0x58[6:5] = 01b section for a more detailed description of what happens when the SYNCB: Register 0x58[6:5] = 01b signal is issued.

Soft SYNC—Register 0x58[2]

A soft SYNC can be issued by means of a bit in Registers 0x58[2]. This soft SYNC works the same as the SYNCB, except that the polarity is reversed. A 1 written to this bit forces the clock outputs into a known state with respect to each other. When a 0 is subsequently written to this bit, the clock outputs continue clocking from that state in synchronicity.

MULTICHIP SYNCHRONIZATION

The AD9510 provides a means of synchronizing two or more AD9510s. This is not an active synchronization; it requires user monitoring and action. The arrangement of two AD9510s to be synchronized is shown in Figure 43.

Synchronization of two or more AD9510s requires a fast clock and a slow clock. The fast clock can be up to 1 GHz and can be the clock driving the master AD9510 CLK1 input or one of the outputs of the master. The fast clock acts as the input to the distribution section of the slave AD9510 and is connected to its CLK1 input. The PLL can be used on the master, but the slave PLL is not used.

The slow clock is the clock that is synchronized across the two chips. This clock must be no faster than one-fourth of the fast clock, and no greater than 250 MHz. The slow clock is taken from one of the outputs of the master AD9510 and acts as the REFIN (or CLK2) input to the slave AD9510. One of the outputs of the slave must provide this same frequency back to the CLK2 (or REFIN) input of the slave.

Multichip synchronization is enabled by writing Register 0x58[0] = 1 on the slave AD9510. When this bit is set, the STATUS pin becomes the output for the SYNC signal. A low signal indicates an in-sync condition, and a high indicates an out-of-sync condition.

Register 0x58[1] selects the number of fast clock cycles that are the maximum separation of the slow clock edges that are considered synchronized. When Register 0x58[1] = 0 (default), the slow clock edges must be coincident within 1 to 1.5 high speed clock cycles. If the coincidence of the slow clock edges is closer than this amount, the SYNC flag stays low. If the coincidence of the slow clock edges is greater than this amount, the SYNC flag is set high. When Register 0x58[1] = 1b, the amount of coincidence required is 0.5 fast clock cycles to 1 fast clock cycles.

Whenever the SYNC flag is set high, indicating an out-of-sync condition, a SYNCB signal applied simultaneously at the FUNCTION pins of both AD9510s brings the slow clocks into synchronization.

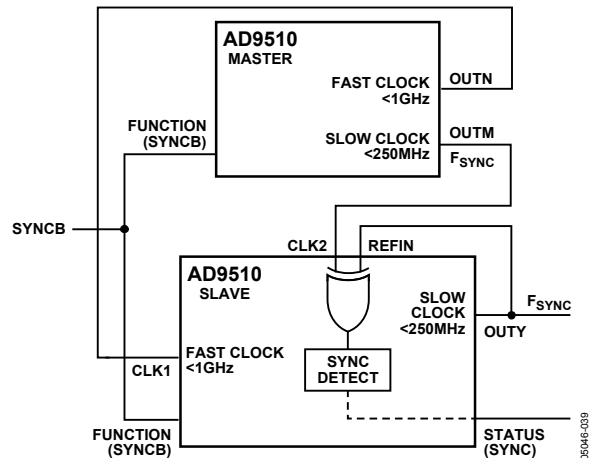

Figure 43. Multichip Synchronization

SERIAL CONTROL PORT

The **AD9510** serial control port is a flexible, synchronous, serial communications port that allows an easy interface with many industry-standard microcontrollers and microprocessors. The **AD9510** serial control port is compatible with most synchronous transfer formats, including both the Motorola SPI® and Intel® SSR® protocols. The serial control port allows read/write access to all registers that configure the **AD9510**. Single or multiple byte transfers are supported, as well as MSB first or LSB first transfer formats. The **AD9510** serial control port can be configured for a single bidirectional input/output pin (SDIO only) or for two unidirectional input/output pins (SDIO/SDO).

SERIAL CONTROL PORT PIN DESCRIPTIONS

SCLK (serial clock) is the serial shift clock. This pin is an input. SCLK is used to synchronize serial control port reads and writes. Write data bits are registered on the rising edge of this clock, and read data bits are registered on the falling edge. This pin is internally pulled down by a 30 kΩ resistor to ground.

SDIO (serial data input/output) is a dual-purpose pin and acts as either an input only or as both an input/output. The **AD9510** defaults to two unidirectional pins for input/output, with SDIO used as an input, and SDO as an output. Alternatively, SDIO can be used as a bidirectional input/output pin by writing to the SDO enable register at Register 0x00[7] = 1b.

SDO (serial data out) is used only in the unidirectional input/output mode (Register 0x00[7] = 0, default) as a separate output pin for reading back data. The **AD9510** defaults to this input/output mode. Bidirectional input/output mode (using SDIO as both input and output) can be enabled by writing to the SDO enable register at Register 0x00[7] = 1.

CSB (chip select bar) is an active low control that gates the read and write cycles. When CSB is high, SDO and SDIO are in a high impedance state. This pin is internally pulled down by a 30 kΩ resistor to ground. Do not leave it unconnected or tied low. See the General Operation of Serial Control Port section on the use of the CSB in a communication cycle.

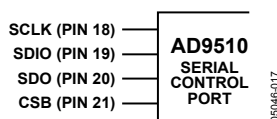

Figure 44. Serial Control Port

GENERAL OPERATION OF SERIAL CONTROL PORT

Framing a Communication Cycle with CSB

Each communications cycle (a write or a read operation) is gated by the CSB line. CSB must be brought low to initiate a communication cycle. CSB must be brought high at the completion of a communication cycle (see Figure 52). If CSB is not brought high at the end of each write or read cycle (on a byte boundary), the last byte is not loaded into the register buffer.

CSB stall high is supported in modes where three or fewer bytes of data (plus instruction data) are transferred (W1:W0 must be

set to 00, 01, or 10, see Table 21). In these modes, CSB can temporarily return high on any byte boundary, allowing time for the system controller to process the next byte. CSB can go high on byte boundaries only and can go high during either part (instruction or data) of the transfer. During this period, the serial control port state machine enters a wait state until all data is sent. If the system controller decides to abort the transfer before all of the data is sent, the state machine must be reset by either completing the remaining transfer or by returning the CSB low for at least one complete SCLK cycle (but less than eight SCLK cycles). Raising the CSB on a nonbyte boundary terminates the serial transfer and flushes the buffer.

In the streaming mode (W1:W0 = 11b), any number of data bytes can be transferred in a continuous stream. The register address is automatically incremented or decremented (see the MSB/LSB First Transfers section). CSB must be raised at the end of the last byte to be transferred, thereby ending the stream mode.

Communication Cycle—Instruction Plus Data

There are two parts to a communication cycle with the **AD9510**. The first writes a 16-bit instruction word into the **AD9510**, coincident with the first 16 SCLK rising edges. The instruction word provides the **AD9510** serial control port with information regarding the data transfer, which is the second part of the communication cycle. The instruction word defines whether the upcoming data transfer is a read or a write, the number of bytes in the data transfer, and the starting register address for the first byte of the data transfer.

Write

If the instruction word is for a write operation (I15 = 0b), the second part is the transfer of data into the serial control port buffer of the **AD9510**. The length of the transfer (1, 2, 3 bytes, or streaming mode) is indicated by 2 bits (W1:W0) in the instruction byte. CSB can be raised after each sequence of 8 bits to stall the bus (except after the last byte, where it ends the cycle). When the bus is stalled, the serial transfer resumes when CSB is lowered. Stalling on nonbyte boundaries resets the serial control port.

Since data is written into a serial control port buffer area, not directly into the actual control registers of the **AD9510**, an additional operation is needed to transfer the serial control port buffer contents to the actual control registers of the **AD9510**, thereby causing them to take effect. This update command consists of writing to Register 0x5A[0] = 1b. This update bit is self-clearing (it is not required to write 0 to it to clear it). Since any number of bytes of data can be changed before issuing an update command, the update simultaneously enables all register changes since any previous update.

Phase offsets or divider synchronization do not become effective until a SYNC is issued (see the Single-Chip Synchronization section).

Read

If the instruction word is for a read operation (I15 = 1b), the next $N \times 8$ SCLK cycles clock out the data from the address specified in the instruction word, where N is 1 to 4 as determined by W1:W0. The readback data is valid on the falling edge of SCLK.

The default mode of the AD9510 serial control port is unidirectional mode; therefore, the requested data appears on the SDO pin. It is possible to set the AD9510 to bidirectional mode by writing the SDO enable register at Register 0x00[7] = 1b. In bidirectional mode, the readback data appears on the SDIO pin.

A readback request reads the data that is in the serial control port buffer area, not the active data in the actual control registers of the AD9510.

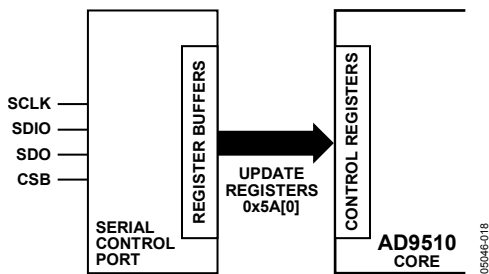

Figure 45. Relationship Between Serial Control Port Register Buffers and Control Registers of the AD9510

The AD9510 uses Address 0x00 to Address 0x5A. Although the AD9510 serial control port allows both 8-bit and 16-bit instructions, the 8-bit instruction mode provides access to five address bits (A4 to A0) only, which restricts its use to the address space Address 0x00 to Address 0x01. The AD9510 defaults to 16-bit instruction mode on power-up. The 8-bit instruction mode (although defined for this serial control port) is not useful for the AD9510; therefore, it is not discussed further in this data sheet.

THE INSTRUCTION WORD (16 BITS)

The MSB of the instruction word is R/\overline{W} , which indicates whether the instruction is a read or a write. The next two bits, W1:W0, indicate the length of the transfer in bytes. The final 13 bits are the address (A12:A0) at which to begin the read or write operation.

For a write, the instruction word is followed by the number of bytes of data indicated by Bits W1:W0, which is interpreted according to Table 21.

Table 21. Byte Transfer Count

W1	W0	Bytes to Transfer
0	0	1
0	1	2
1	0	3
1	1	Streaming mode

A12:A0: These 13 bits select the address within the register map that is written to or read from during the data transfer portion of the communications cycle. The AD9510 does not use all of the 13-bit address space. Only Bits[A6:A0] are needed to cover the range of the Address 0x5A registers used by the AD9510. Bits[A12:A7] must always be 0b. For multibyte transfers, this address is the starting byte address. In MSB first mode, subsequent bytes increment the address.

MSB/LSB FIRST TRANSFERS

The AD9510 instruction word and byte data can be MSB first or LSB first. The default for the AD9510 is MSB first. Set the LSB first mode by writing 1b to Register 0x00[6]. This takes effect immediately (since it only affects the operation of the serial control port) and does not require that an update be executed. Immediately after the LSB first bit is set, all serial control port operations are changed to LSB first order.

When MSB first mode is active, the instruction and data bytes must be written from MSB to LSB. Multibyte data transfers in MSB first format start with an instruction byte that includes the register address of the most significant data byte. Subsequent data bytes must follow in order from high address to low address. In MSB first mode, the serial control port internal address generator decrements for each data byte of the multibyte transfer cycle.

When LSB_FIRST = 1b (LSB first), the instruction and data bytes must be written from LSB to MSB. Multibyte data transfers in LSB first format start with an instruction byte that includes the register address of the least significant data byte followed by multiple data bytes. The serial control port internal byte address generator increments for each byte of the multibyte transfer cycle.

The AD9510 serial control port register address decrements from the register address just written toward Address 0x0000 for multibyte input/output operations if the MSB first mode is active (default). If the LSB first mode is active, the serial control port register address increments from the address just written toward Address 0x1FFF for multibyte input/output operations.

Unused addresses are not skipped during multibyte input/output operations; therefore, it is important to avoid multibyte input/output operations that would include these addresses.

Table 22. Serial Control Port, 16-Bit Instruction Word, MSB First

MSB														LSB	
I15	I14	I13	I12	I11	I10	I9	I8	I7	I6	I5	I4	I3	I2	I1	I0
R/W	W1	W0	A12 = 0	A11 = 0	A10 = 0	A9 = 0	A8 = 0	A7 = 0	A6	A5	A4	A3	A2	A1	A0

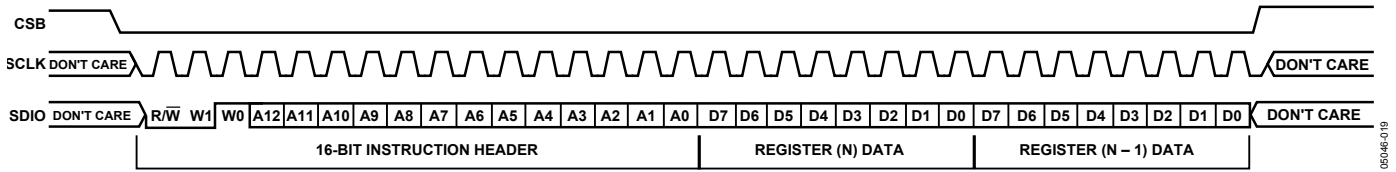

Figure 46. Serial Control Port Write—MSB First, 16-Bit Instruction, 2 Bytes Data

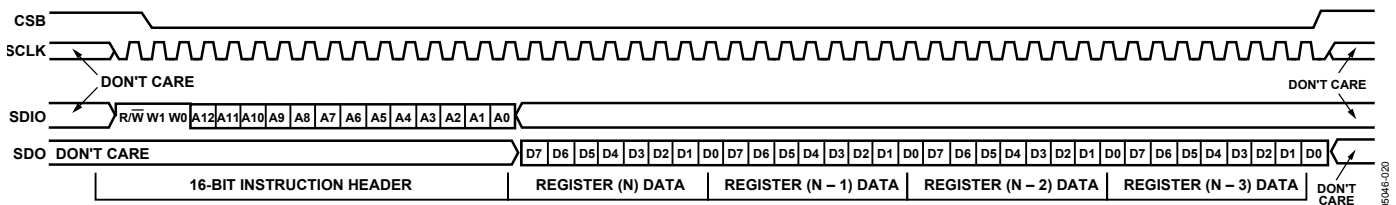

Figure 47. Serial Control Port Read—MSB First, 16-Bit Instruction, 4 Bytes Data

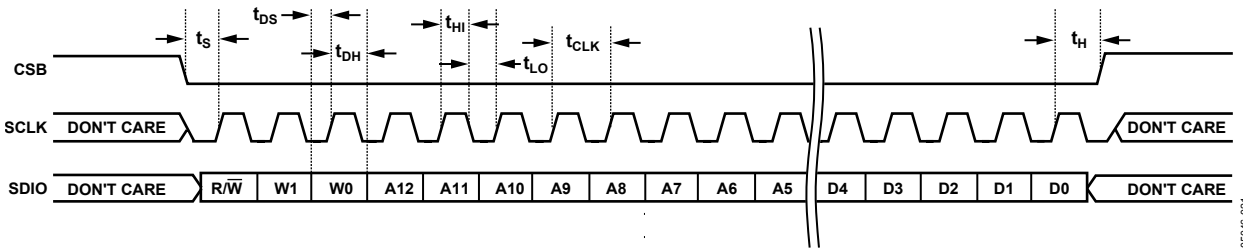

Figure 48. Serial Control Port Write—MSB First, 16-Bit Instruction, Timing Measurements

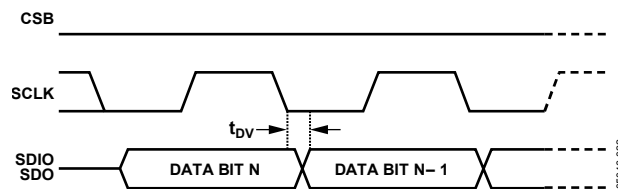

Figure 49. Timing Diagram for Serial Control Port Register Read

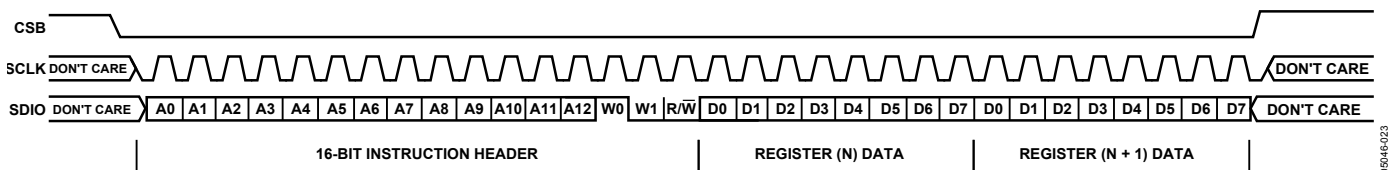

Figure 50. Serial Control Port Write—LSB First, 16-Bit Instruction, 2 Bytes Data

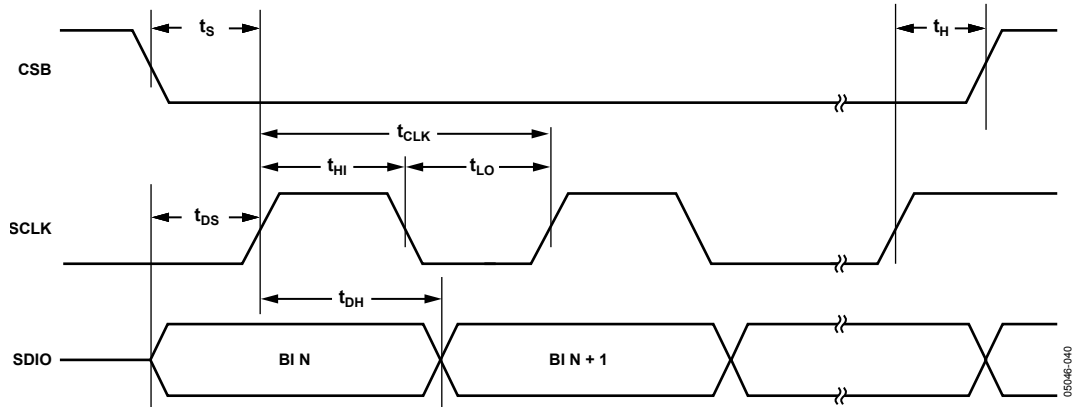
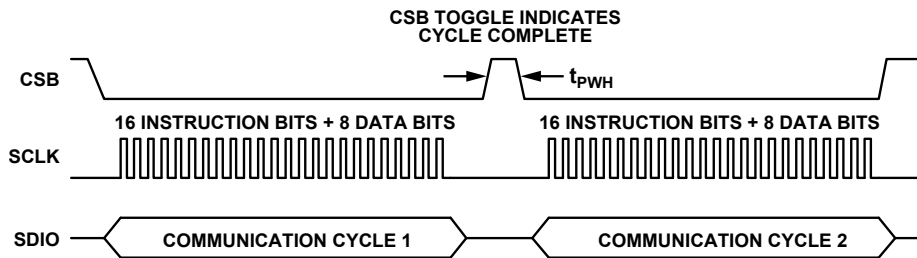

Figure 51. Serial Control Port Timing—Write

Table 23. Serial Control Port Timing

Parameter	Description
t_{DS}	Setup time between data and rising edge of SCLK
t_{DH}	Hold time between data and rising edge of SCLK
t_{CLK}	Period of the clock
t_s	Setup time between CSB and SCLK
t_H	Hold time between CSB and SCLK
t_{HI}	Minimum period that SCLK must be in a logic high state
t_{LO}	Minimum period that SCLK must be in a logic low state



TIMING DIAGRAM FOR TWO SUCCESSIVE COMMUNICATION CYCLES. NOTE THAT CSB MUST BE TOGGLED HIGH AND THEN LOW AT THE COMPLETION OF A COMMUNICATION CYCLE.

Figure 52. Use of CSB to Define Communications Cycle

REGISTER MAP AND DESCRIPTION

SUMMARY TABLE

Table 24. AD9510 Register Map

Addr (Hex)	Parameter	Bit 7 (MSB)	Bit 6	Bit 5	Bit 4	Bit 3	Bit 2	Bit 1	Bit 0 (LSB)	Def. Value (Hex)	Notes		
00	Serial control port configuration	SDO inactive (bidirectional mode)	LSB_FIRST	Soft reset	Long instruction	Not used				10			
01		Not used											
02		Not used											
03		Not used											
	PLL											PLL starts in power-down	
04	A counter	Not used		6-Bit A counter[5:0]							00	N divider (A)	
05	B counter	Not used			13-Bit B counter, Bits[12:8], MSB[4:0]							00	N divider (B)
06	B counter	13-Bit B counter, Bits[7:0], LSB[7:0]										00	N divider (B)
07	PLL 1	Not used	LOR LOCK_DEL[6:5]		Not used		LOR enable	Not used			00		
08	PLL 2	Not used	PFD polarity	PLL mux select[5:2] signal on STATUS pin			CP mode[1:0]			00			
09	PLL 3	Not used	CP current[6:4]			Not used	Reset R counter	Reset N counter	Reset All counters		00		
0A	PLL 4	Not used	B bypass	Not used	Prescaler P[4:2]			Power-down[1:0]			01	N divider (P)	
0B	R divider	Not used		14-Bit R divider, Bits[13:8], MSB[5:0]							00	R divider	
0C	R divider	14-Bit R divider, Bits[13:8], MSB[7:0]										00	R divider
0D	PLL 5	Not used	Digital lock det. enable	Digital lock det. window	Not used			Antibacklash pulse width[1:0]			00		
0E33		Not used											
	Fine delay adjust											Fine delays bypassed	
34	Delay Bypass 5	Not used							Bypass		01	Bypass delay	
35	Delay Full-Scale 5	Not used		Ramp capacitor[5:3]			Ramp current [2:0]			00	Max. delay full-scale		
36	Delay Fine Adjust 5	Not used		5-bit fine delay[5:1] (00000b to 11000b)					Must be 0		00	Min. delay value	
37		Not used										04	
38	Delay Bypass 6	Not used							Bypass		01	Bypass delay	
39	Delay Full-Scale 6	Not used		Ramp capacitor[5:3]			Ramp current[2:0]			00	Max. delay full-scale		
3A	Delay Fine Adjust 6	Not used		5-bit fine delay[5:1] (00000b to 11000b)					Not used		00	Min. delay value	
3B		Not used										04	
	Outputs												
3C	LVPECL OUT0	Not used				Output level[3:2]		Power-down[1:0]			0A	Off	
3D	LVPECL OUT1	Not used				Output level[3:2]		Power-down[1:0]			08	On	

Addr (Hex)	Parameter	Bit 7 (MSB)	Bit 6	Bit 5	Bit 4	Bit 3	Bit 2	Bit 1	Bit 0 (LSB)	Def. Value (Hex)	Notes
3E	LVPECL OUT2	Not used				Output level[3:2]		Power-down[1:0]		08	On
3F	LVPECL OUT3	Not used				Output level[3:2]		Power-down[1:0]		08	On
40	LVDS_CMOS OUT4	Not used			CMOS inverted driver on	Logic select	Output level[2:1]		Output power	02	LVDS, on
41	LVDS_CMOS OUT5	Not used			CMOS inverted driver on	Logic select	Output level[2:1]		Output power	02	LVDS, on
42	LVDS_CMOS OUT6	Not used			CMOS inverted driver on	Logic select	Output level[2:1]		Output power	03	LVDS, off
43	LVDS_CMOS OUT7	Not used			CMOS inverted driver on	Logic select	Output level[2:1]		Output power	03	LVDS, off
44		Not used									
	CLK1 and CLK2										Input receivers
45	Clocks select, power-down (PD) options	Not used		CLKs in PD	REFIN PD	CLK to PLL PD	CLK2 PD	CLK1 PD	Select CLK IN	01	All clocks on, select CLK1
46, 47		Not used									
	Dividers										
48	Divider 0	Low cycles[7:4]				High cycles[3:0]				00	Divide by 2
49	Divider 0	Bypass	No sync	Force	Start H/L	Phase offset[3:0]				00	Phase = 0
4A	Divider 1	Low cycles[7:4]				High cycles[3:0]				00	Divide by 2
4B	Divider 1	Bypass	No sync	Force	Start H/L	Phase offset[3:0]				00	Phase = 0
4C	Divider 2	Low cycles[7:4]				High cycles[3:0]				11	Divide by 4
4D	Divider 2	Bypass	No sync	Force	Start H/L	Phase offset[3:0]				00	Phase = 0
4E	Divider 3	Low cycles[7:4]				High cycles[3:0]				33	Divide by 8
4F	Divider 3	Bypass	No sync	Force	Start H/L	Phase offset[3:0]				00	Phase = 0
50	Divider 4	Low cycles[7:4]				High cycles[3:0]				00	Divide by 2
51	Divider 4	Bypass	No sync	Force	Start H/L	Phase offset[3:0]				00	Phase = 0
52	Divider 5	Low cycles[7:4]				High cycles[3:0]				11	Divide by 4
53	Divider 5	Bypass	No sync	Force	Start H/L	Phase offset[3:0]				00	Phase = 0
54	Divider 6	Low cycles[7:4]				High cycles[3:0]				00	Divide by 2
55	Divider 6	Bypass	No sync	Force	Start H/L	Phase offset[3:0]				00	Phase = 0
56	Divider 7	Low cycles[7:4]				High cycles[3:0]				00	Divide by 2
57	Divider 7	Bypass	No sync	Force	Start H/L	Phase offset[3:0]				00	Phase = 0
	Function										
58	FUNCTION Pin and sync	Not used	Set FUNCTION Pin		PD sync	PD all ref.	Sync reg.	Sync select	Sync enable	00	FUNCTION pin = RESETB
59		Not used									
5A	Update registers	Not used							Update registers	00	Self-clearing bit
	END										

Reg. Addr. (Hex)	Bit(s)	Name	Description																																																																																					
08	[5:2]	PLL mux control	<table border="1"> <thead> <tr> <th>[5]</th> <th>[4]</th> <th>[3]</th> <th>[2]</th> <th>MUXOUT—Signal on STATUS Pin</th> </tr> </thead> <tbody> <tr><td>0</td><td>0</td><td>0</td><td>0</td><td>Off (signal goes low) (default)</td></tr> <tr><td>0</td><td>0</td><td>0</td><td>1</td><td>Digital lock detect (active high)</td></tr> <tr><td>0</td><td>0</td><td>1</td><td>0</td><td>N divider output</td></tr> <tr><td>0</td><td>0</td><td>1</td><td>1</td><td>Digital lock detect (active low)</td></tr> <tr><td>0</td><td>1</td><td>0</td><td>0</td><td>R divider output</td></tr> <tr><td>0</td><td>1</td><td>0</td><td>1</td><td>Analog lock detect (N channel, open-drain)</td></tr> <tr><td>0</td><td>1</td><td>1</td><td>0</td><td>A counter output</td></tr> <tr><td>0</td><td>1</td><td>1</td><td>1</td><td>Prescaler output (NCLK)</td></tr> <tr><td>1</td><td>0</td><td>0</td><td>0</td><td>PFD up pulse</td></tr> <tr><td>1</td><td>0</td><td>0</td><td>1</td><td>PFD down pulse</td></tr> <tr><td>1</td><td>0</td><td>1</td><td>0</td><td>Loss of reference (active high)</td></tr> <tr><td>1</td><td>0</td><td>1</td><td>1</td><td>Tristate</td></tr> <tr><td>1</td><td>1</td><td>0</td><td>0</td><td>Analog lock detect (P channel, open-drain)</td></tr> <tr><td>1</td><td>1</td><td>0</td><td>1</td><td>Loss of reference or loss of lock (inverse of DLD) (active high)</td></tr> <tr><td>1</td><td>1</td><td>1</td><td>0</td><td>Loss of reference or loss of lock (inverse of DLD) (active low)</td></tr> <tr><td>1</td><td>1</td><td>1</td><td>1</td><td>Loss of reference (active low)</td></tr> </tbody> </table>	[5]	[4]	[3]	[2]	MUXOUT—Signal on STATUS Pin	0	0	0	0	Off (signal goes low) (default)	0	0	0	1	Digital lock detect (active high)	0	0	1	0	N divider output	0	0	1	1	Digital lock detect (active low)	0	1	0	0	R divider output	0	1	0	1	Analog lock detect (N channel, open-drain)	0	1	1	0	A counter output	0	1	1	1	Prescaler output (NCLK)	1	0	0	0	PFD up pulse	1	0	0	1	PFD down pulse	1	0	1	0	Loss of reference (active high)	1	0	1	1	Tristate	1	1	0	0	Analog lock detect (P channel, open-drain)	1	1	0	1	Loss of reference or loss of lock (inverse of DLD) (active high)	1	1	1	0	Loss of reference or loss of lock (inverse of DLD) (active low)	1	1	1	1	Loss of reference (active low)
			[5]	[4]	[3]	[2]	MUXOUT—Signal on STATUS Pin																																																																																	
			0	0	0	0	Off (signal goes low) (default)																																																																																	
			0	0	0	1	Digital lock detect (active high)																																																																																	
			0	0	1	0	N divider output																																																																																	
			0	0	1	1	Digital lock detect (active low)																																																																																	
			0	1	0	0	R divider output																																																																																	
			0	1	0	1	Analog lock detect (N channel, open-drain)																																																																																	
			0	1	1	0	A counter output																																																																																	
			0	1	1	1	Prescaler output (NCLK)																																																																																	
			1	0	0	0	PFD up pulse																																																																																	
			1	0	0	1	PFD down pulse																																																																																	
			1	0	1	0	Loss of reference (active high)																																																																																	
			1	0	1	1	Tristate																																																																																	
			1	1	0	0	Analog lock detect (P channel, open-drain)																																																																																	
			1	1	0	1	Loss of reference or loss of lock (inverse of DLD) (active high)																																																																																	
1	1	1	0	Loss of reference or loss of lock (inverse of DLD) (active low)																																																																																				
1	1	1	1	Loss of reference (active low)																																																																																				
			MUXOUT is the PLL portion of the STATUS output MUX.																																																																																					
08	[6]	Phase frequency detector (PFD) polarity	0 = negative (default), 1 = positive.																																																																																					
08	[7]		Not used.																																																																																					
09	[0]	Reset all counters	0 = normal (default), 1 = reset R, A, and B counters.																																																																																					
09	[1]	N-counter reset	0 = normal (default), 1 = reset A and B counters.																																																																																					
09	[2]	R-counter reset	0 = normal (default), 1 = reset R counter.																																																																																					
09	[3]		Not used.																																																																																					
09	[6:4]	Charge pump (CP) current setting	<table border="1"> <thead> <tr> <th>[6]</th> <th>[5]</th> <th>[4]</th> <th>ICP (mA)</th> </tr> </thead> <tbody> <tr><td>0</td><td>0</td><td>0</td><td>0.60</td></tr> <tr><td>0</td><td>0</td><td>1</td><td>1.2</td></tr> <tr><td>0</td><td>1</td><td>0</td><td>1.8</td></tr> <tr><td>0</td><td>1</td><td>1</td><td>2.4</td></tr> <tr><td>1</td><td>0</td><td>0</td><td>3.0</td></tr> <tr><td>1</td><td>0</td><td>1</td><td>3.6</td></tr> <tr><td>1</td><td>1</td><td>0</td><td>4.2</td></tr> <tr><td>1</td><td>1</td><td>1</td><td>4.8</td></tr> </tbody> </table>	[6]	[5]	[4]	ICP (mA)	0	0	0	0.60	0	0	1	1.2	0	1	0	1.8	0	1	1	2.4	1	0	0	3.0	1	0	1	3.6	1	1	0	4.2	1	1	1	4.8																																																	
			[6]	[5]	[4]	ICP (mA)																																																																																		
			0	0	0	0.60																																																																																		
			0	0	1	1.2																																																																																		
			0	1	0	1.8																																																																																		
			0	1	1	2.4																																																																																		
			1	0	0	3.0																																																																																		
			1	0	1	3.6																																																																																		
			1	1	0	4.2																																																																																		
			1	1	1	4.8																																																																																		
			Default = 000b.																																																																																					
			These currents assume: $CPR_{SET} = 5.1 \text{ k}\Omega$.																																																																																					
			Actual current can be calculated by: $CP_{LSB} = 3.06/CPR_{SET}$.																																																																																					
09	[7]		Not used.																																																																																					
0A	[1:0]	PLL power-down	01 = Asynchronous power-down (default).																																																																																					
			<table border="1"> <thead> <tr> <th>[1]</th> <th>[0]</th> <th>Mode</th> </tr> </thead> <tbody> <tr><td>0</td><td>0</td><td>Normal operation</td></tr> <tr><td>0</td><td>1</td><td>Asynchronous power-down</td></tr> <tr><td>1</td><td>0</td><td>Normal operation</td></tr> <tr><td>1</td><td>1</td><td>Synchronous power-down</td></tr> </tbody> </table>	[1]	[0]	Mode	0	0	Normal operation	0	1	Asynchronous power-down	1	0	Normal operation	1	1	Synchronous power-down																																																																						
			[1]	[0]	Mode																																																																																			
			0	0	Normal operation																																																																																			
			0	1	Asynchronous power-down																																																																																			
1	0	Normal operation																																																																																						
1	1	Synchronous power-down																																																																																						

Reg. Addr. (Hex)	Bit(s)	Name	Description				
0A	[4:2]	Prescaler value (P/P + 1)					
			[4]	[3]	[2]	Mode	Prescaler Mode
			0	0	0	FD	Divide by 1
			0	0	1	FD	Divide by 2
			0	1	0	DM	2/3
			0	1	1	DM	4/5
			1	0	0	DM	8/9
			1	0	1	DM	16/17
			1	1	0	DM	32/33
			1	1	1	FD	Divide by 3
			DM = dual modulus, FD = fixed divide.				
0A	[5]		Not used.				
0A	[6]	B counter bypass	Only valid when operating the prescaler in fixed divide (FD) mode. When this bit is set, the B counter is divided by 1. This allows the prescaler setting to determine the divide for the N divider.				
0A	[7]		Not used.				
0B	[5:0]	14-bit reference counter, R MSBs	R divider MSB[13:8].				
0C	[7:0]	14-bit reference counter, R LSBs	R divider MSB[7:0].				
0D	[1:0]	Antibacklash pulse width					
			[1]	[0]	Antibacklash Pulse Width (ns)		
			0	0	1.3 (default)		
			0	1	2.9		
			1	0	6.0		
1	1	1.3					
0D	[4:2]		Not used				
0D	[5]	Digital lock detect window					
			[5]	Digital Lock Detect Window (ns)	Digital Lock Detect Loss of Lock Threshold (ns)		
			0 (default)	9.5	15		
			1	3.5	7		
			If the time difference of the rising edges at the inputs to the PFD are less than the lock detect window time, the digital lock detect flag is set. The flag remains set until the time difference is greater than the loss of lock threshold.				
0D	[6]	Lock detect disable	0 = normal lock detect operation (default), 1 = disable lock detect.				
0D	[7]		Not used.				
		Unused					
0E33			Not used.				
	Fine delay adjust						
34 38	[0]	Delay control	Delay block control bit.				
		OUT5 OUT6	Bypasses delay block and powers it down (default = 1b).				
34 38	[7:1]		Not used.				

Reg. Addr. (Hex)	Bit(s)	Name	Description																																				
35 39	[2:0]	Ramp current OUT5 OUT6	The slowest ramp (200 μ A) sets the longest full scale of approximately 10 ns. <table border="1"> <thead> <tr> <th>[2]</th> <th>[1]</th> <th>[0]</th> <th>Ramp Current (μA)</th> </tr> </thead> <tbody> <tr><td>0</td><td>0</td><td>0</td><td>200</td></tr> <tr><td>0</td><td>0</td><td>1</td><td>400</td></tr> <tr><td>0</td><td>1</td><td>0</td><td>600</td></tr> <tr><td>0</td><td>1</td><td>1</td><td>800</td></tr> <tr><td>1</td><td>0</td><td>0</td><td>1000</td></tr> <tr><td>1</td><td>0</td><td>1</td><td>1200</td></tr> <tr><td>1</td><td>1</td><td>0</td><td>1400</td></tr> <tr><td>1</td><td>1</td><td>1</td><td>1600</td></tr> </tbody> </table>	[2]	[1]	[0]	Ramp Current (μ A)	0	0	0	200	0	0	1	400	0	1	0	600	0	1	1	800	1	0	0	1000	1	0	1	1200	1	1	0	1400	1	1	1	1600
[2]	[1]	[0]	Ramp Current (μ A)																																				
0	0	0	200																																				
0	0	1	400																																				
0	1	0	600																																				
0	1	1	800																																				
1	0	0	1000																																				
1	0	1	1200																																				
1	1	0	1400																																				
1	1	1	1600																																				
35 39	[5:3]	Ramp capacitor OUT5 OUT6	Selects the number of capacitors in ramp generation circuit. More capacitors \rightarrow slower ramp. <table border="1"> <thead> <tr> <th>[5]</th> <th>[4]</th> <th>[3]</th> <th>Number of Capacitors</th> </tr> </thead> <tbody> <tr><td>0</td><td>0</td><td>0</td><td>4 (default)</td></tr> <tr><td>0</td><td>0</td><td>1</td><td>3</td></tr> <tr><td>0</td><td>1</td><td>0</td><td>3</td></tr> <tr><td>0</td><td>1</td><td>1</td><td>2</td></tr> <tr><td>1</td><td>0</td><td>0</td><td>3</td></tr> <tr><td>1</td><td>0</td><td>1</td><td>2</td></tr> <tr><td>1</td><td>1</td><td>0</td><td>2</td></tr> <tr><td>1</td><td>1</td><td>1</td><td>1</td></tr> </tbody> </table>	[5]	[4]	[3]	Number of Capacitors	0	0	0	4 (default)	0	0	1	3	0	1	0	3	0	1	1	2	1	0	0	3	1	0	1	2	1	1	0	2	1	1	1	1
[5]	[4]	[3]	Number of Capacitors																																				
0	0	0	4 (default)																																				
0	0	1	3																																				
0	1	0	3																																				
0	1	1	2																																				
1	0	0	3																																				
1	0	1	2																																				
1	1	0	2																																				
1	1	1	1																																				
36 3A	[5:1]	Delay fine adjust OUT5 OUT6	Sets delay within full scale of the ramp; there are 25 steps. 00000 \rightarrow zero delay (default). 11000 \rightarrow maximum delay.																																				
3C 3D 3E 3F	[1:0]	Power-down LVPECL OUT0 OUT1 OUT2 OUT3	<table border="1"> <thead> <tr> <th>Mode</th> <th>[1]</th> <th>[0]</th> <th>Description</th> <th>Output</th> </tr> </thead> <tbody> <tr> <td>On</td> <td>0</td> <td>0</td> <td>Normal operation.</td> <td>On</td> </tr> <tr> <td>PD1</td> <td>0</td> <td>1</td> <td>Test only—do not use.</td> <td>Off</td> </tr> <tr> <td>PD2</td> <td>1</td> <td>0</td> <td>Safe power-down. Partial power-down; use if output has load resistors.</td> <td>Off</td> </tr> <tr> <td>PD3</td> <td>1</td> <td>1</td> <td>Total power-down. Use only if output has no load resistors.</td> <td>Off</td> </tr> </tbody> </table>	Mode	[1]	[0]	Description	Output	On	0	0	Normal operation.	On	PD1	0	1	Test only—do not use.	Off	PD2	1	0	Safe power-down. Partial power-down; use if output has load resistors.	Off	PD3	1	1	Total power-down. Use only if output has no load resistors.	Off											
Mode	[1]	[0]	Description	Output																																			
On	0	0	Normal operation.	On																																			
PD1	0	1	Test only—do not use.	Off																																			
PD2	1	0	Safe power-down. Partial power-down; use if output has load resistors.	Off																																			
PD3	1	1	Total power-down. Use only if output has no load resistors.	Off																																			
3C 3D 3E 3F	[3:2]	Output level LVPECL OUT0 OUT1 OUT2 OUT3	Output single-ended voltage levels for LVPECL outputs. <table border="1"> <thead> <tr> <th>[3]</th> <th>[2]</th> <th>Output Voltage (mV)</th> </tr> </thead> <tbody> <tr><td>0</td><td>0</td><td>500</td></tr> <tr><td>0</td><td>1</td><td>340</td></tr> <tr><td>1</td><td>0</td><td>810 (default)</td></tr> <tr><td>1</td><td>1</td><td>660</td></tr> </tbody> </table>	[3]	[2]	Output Voltage (mV)	0	0	500	0	1	340	1	0	810 (default)	1	1	660																					
[3]	[2]	Output Voltage (mV)																																					
0	0	500																																					
0	1	340																																					
1	0	810 (default)																																					
1	1	660																																					

Reg. Addr. (Hex)	Bit(s)	Name	Description																				
3C 3D 3E 3F	[7:4]		Not used.																				
40 41 42 43	[0]	Power-down LVDS/CMOS OUT4 OUT5 OUT6 OUT7	Power-down bit for both output and LVDS driver. 0 = LVDS/CMOS on (default), 1 = LVDS/CMOS power-down.																				
40 41 42 43	[2:1]	Output current level LVDS OUT4 OUT5 OUT6 OUT7	<table border="1"> <thead> <tr> <th>[2]</th> <th>[1]</th> <th>Current (mA)</th> <th>Termination (Ω)</th> </tr> </thead> <tbody> <tr> <td>0</td> <td>0</td> <td>1.75</td> <td>100</td> </tr> <tr> <td>0</td> <td>1</td> <td>3.5 (default)</td> <td>100</td> </tr> <tr> <td>1</td> <td>0</td> <td>5.25</td> <td>50</td> </tr> <tr> <td>1</td> <td>1</td> <td>7</td> <td>50</td> </tr> </tbody> </table>	[2]	[1]	Current (mA)	Termination (Ω)	0	0	1.75	100	0	1	3.5 (default)	100	1	0	5.25	50	1	1	7	50
[2]	[1]	Current (mA)	Termination (Ω)																				
0	0	1.75	100																				
0	1	3.5 (default)	100																				
1	0	5.25	50																				
1	1	7	50																				
40 41 42 43	[3]	LVDS/CMOS select OUT4 OUT5 OUT6 OUT7	0 = LVDS (default), 1 = CMOS.																				
40 41 42 43	[4]	Inverted CMOS driver OUT4 OUT5 OUT6 OUT7	Effects output only when in CMOS mode. 0 = disable inverted CMOS driver (default), 1 = enable inverted CMOS driver.																				
40 41 42 43	[7:5]		Not used.																				
44	[7:0]		Not used.																				
45	[0]	Clock select	0: CLK2 drives distribution section, 1: CLK1 drives distribution section (default).																				
45	[1]	CLK1 power-down	1 = CLK1 input is powered down (default = 0b).																				
45	[2]	CLK2 power-down	1 = CLK2 input is powered down (default = 0b).																				
45	[3]	Prescaler clock power-down	1 = shut down clock signal to PLL prescaler (default = 0b).																				
45	[4]	REFIN power-down	1 = power-down REFIN (default = 0b).																				
45	[5]	All clock inputs power-down	1 = power-down CLK1 and CLK2 inputs and associated bias and internal clock tree (default = 0b).																				
45	[7:6]		Not used.																				
46	[7:0]		Not used.																				
47	[7:0]		Not used.																				

Reg. Addr. (Hex)	Bit(s)	Name	Description
48 4A 4C 4E 50 52 54 56	[3:0]	Divider high OUT0 OUT1 OUT2 OUT3 OUT4 OUT5 OUT6 OUT7	Number of clock cycles divider output stays high.
48 4A 4C 4E 50 52 54 56	[7:4]	Divider low OUT0 OUT1 OUT2 OUT3 OUT4 OUT5 OUT6 OUT7	Number of clock cycles divider output stays low.
49 4B 4D 4F 51 53 55 57	[3:0]	Phase offset OUT0 OUT1 OUT2 OUT3 OUT4 OUT5 OUT6 OUT7	Phase offset (default = 0000b).
49 4B 4D 4F 51 53 55 57	[4]	Start OUT0 OUT1 OUT2 OUT3 OUT4 OUT5 OUT6 OUT7	Selects start high or start low (default = 0b).
49 4B 4D 4F 51 53 55 57	[5]	Force OUT0 OUT1 OUT2 OUT3 OUT4 OUT5 OUT6 OUT7	Forces individual outputs to the state specified in start (see the previous section of this table). This function requires that Nosync (see the next section of this table) also be set (default = 0b).

Reg. Addr. (Hex)	Bit(s)	Name	Description															
49 4B 4D 4F 51 53 55 57	[6]	Nosync OUT0 OUT1 OUT2 OUT3 OUT4 OUT5 OUT6 OUT7	Ignore chip-level sync signal (default = 0b).															
49 4B 4D 4F 51 53 55 57	[7]	Bypass divider OUT0 OUT1 OUT2 OUT3 OUT4 OUT5 OUT6 OUT7	Bypass and power down divider logic; route clock directly to output (default = 0b).															
58	[0]	SYNC detect enable	1 = enable SYNC detect (default = 0b).															
58	[1]	SYNC select	1 = raise flag if slow clocks are out-of-sync by 0.5 to 1 high speed clock cycles. 0 (default) = raise flag if slow clocks are out-of-sync by 1 to 1.5 high speed clock cycles.															
58	[2]	Soft SYNC	The Soft SYNC bit works the same as the FUNCTION pin when in SYNCB mode, except that the polarity of this bit is reversed. That is, a high level forces selected outputs into a known state, and a high > low transition triggers a sync (default = 0b).															
58	[3]	Dist ref power-down	1 = power down the references for the distribution section (default = 0b).															
58	[4]	SYNC power-down	1 = power down the SYNC (default = 0b).															
58	[6:5]	FUNCTION pin select	<table border="1"> <thead> <tr> <th>[6]</th> <th>[5]</th> <th>Function</th> </tr> </thead> <tbody> <tr> <td>0</td> <td>0</td> <td>RESETB (default)</td> </tr> <tr> <td>0</td> <td>1</td> <td>SYNCB</td> </tr> <tr> <td>1</td> <td>0</td> <td>Test only, do not use</td> </tr> <tr> <td>1</td> <td>1</td> <td>PDB</td> </tr> </tbody> </table>	[6]	[5]	Function	0	0	RESETB (default)	0	1	SYNCB	1	0	Test only, do not use	1	1	PDB
[6]	[5]	Function																
0	0	RESETB (default)																
0	1	SYNCB																
1	0	Test only, do not use																
1	1	PDB																
58	[7]		Not used.															
59	[7:0]		Not used.															
5A	[0]	Update registers	Writing a 1 to this bit updates all registers and transfers all serial control port register buffer contents to the control registers on the next rising SCLK edge. This is a self-clearing bit; a 0 does not have to be written to clear it.															
5A	[7:1]		Not used.															
End																		

POWER SUPPLY

The [AD9510](#) requires a $3.3\text{ V} \pm 5\%$ power supply for V_S . The tables in the Specifications section give the performance expected from the [AD9510](#) with the power supply voltage within this range. The absolute maximum range of $-0.3\text{ V} - +3.6\text{ V}$, with respect to GND, must never be exceeded on the V_S pin.

Follow good engineering practice in the layout of power supply traces and the ground plane of the printed circuit board (PCB). Bypass the power supply on the PCB with adequate capacitance ($>10\text{ }\mu\text{F}$). Bypass the [AD9510](#) with adequate capacitors ($0.1\text{ }\mu\text{F}$) at all power pins as close as possible to the part. The layout of the [AD9510](#) evaluation board ([AD9510/PCBZ](#) or [AD9510-VCO/PCBZ](#)) is a good example.

The [AD9510](#) is a complex part that is programmed for its desired operating configuration by on-chip registers. These registers are not maintained over a shutdown of external power. This means that the registers can lose their programmed values if V_S is lost long enough for the internal voltages to collapse. Careful bypassing protects the part from memory loss under normal conditions. Nonetheless, it is important that the V_S power supply not become intermittent, or the [AD9510](#) risks losing its programming.

The internal bias currents of the [AD9510](#) are set by the R_{SET} and CPR_{SET} resistors. These resistors must be as close as possible to the values given as conditions in the Specifications section ($R_{\text{SET}} = 4.12\text{ k}\Omega$ and $\text{CPR}_{\text{SET}} = 5.1\text{ k}\Omega$). These values are standard 1% resistor values, and are readily obtainable. The bias currents set by these resistors determine the logic levels and operating conditions of the internal blocks of the [AD9510](#). The performance figures given in the Specifications section assume that these resistor values are used.

The VCP pin is the supply pin for the charge pump (CP). The voltage at this pin (V_{CP}) can be from V_S up to 5.5 V , as required to match the tuning voltage range of a specific VCO/VCXO. This voltage must never exceed the absolute maximum of 6 V . Additionally, never allow V_{CP} to be less than -0.3 V below V_S or GND, whichever is lower.

The exposed metal paddle on the [AD9510](#) package is an electrical connection, as well as a thermal enhancement. For the device to function properly, the paddle must be properly attached to ground (GND). The PCB acts as a heat sink for the [AD9510](#); therefore, this GND connection must provide a good thermal path to a larger dissipation area, such as a ground plane on the PCB. See the layout of the [AD9510](#) evaluation board ([AD9510/PCBZ](#) or [AD9510-VCO/PCBZ](#)) for a good example.

POWER MANAGEMENT

The power usage of the [AD9510](#) can be managed to use only the power required for the functions being used. Unused features and circuitry can be powered down to save power. The following circuit blocks can be powered down, or are powered down when not selected (see the Register Map and Description section):

- The PLL section can be powered down if not needed.
- Any of the dividers are powered down when bypassed—equivalent to divide-by-one.
- The adjustable delay blocks on OUT5 and OUT6 are powered down when not selected.
- Any output can be powered down. However, LVPECL outputs have both a safe and an off condition. When the LVPECL output is terminated, use only the safe shutdown to protect the LVPECL output devices. This still consumes some power.
- The entire distribution section can be powered down when not needed.

Powering down a functional block does not cause the programming information for that block (in the registers) to be lost. This means that blocks can be powered on and off without otherwise having to reprogram the [AD9510](#). However, synchronization is lost. A SYNC must be issued to resynchronize (see the Single-Chip Synchronization section).

APPLICATIONS INFORMATION

USING THE AD9510 OUTPUTS FOR ADC CLOCK APPLICATIONS

Any high speed ADC is extremely sensitive to the quality of the sampling clock provided by the user. An ADC can be thought of as a sampling mixer; any noise, distortion, or timing jitter on the clock is combined with the desired signal at the analog-to-digital output. Clock integrity requirements scale with the analog input frequency and resolution, with higher analog input frequency applications at ≥ 14 -bit resolution being the most stringent. The theoretical SNR of an ADC is limited by the ADC resolution and the jitter on the sampling clock. Considering an ideal ADC of infinite resolution where the step size and quantization error can be ignored, the available SNR can be expressed approximately by

$$SNR = 20 \times \log \left[\frac{1}{2\pi f t_j} \right]$$

where:

f is the highest analog frequency being digitized.

t_j is the rms jitter on the sampling clock.

Figure 53 shows the required sampling clock jitter as a function of the analog frequency and effective number of bits (ENOB).

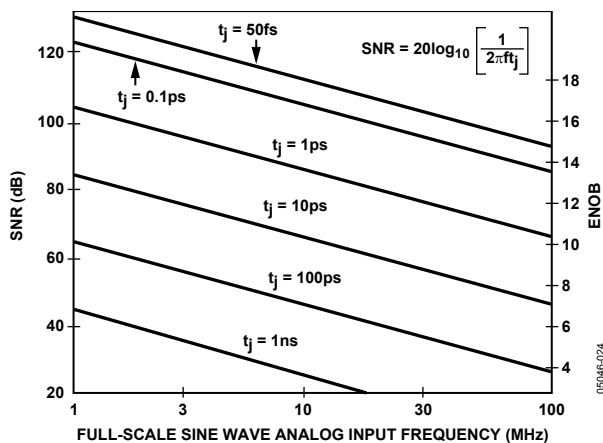

Figure 53. ENOB and SNR vs. Analog Input Frequency

See [Application Note AN-756, Sampled Systems and the Effects of Clock Phase Noise and Jitter](#), and [Application Note AN-501, Aperture Uncertainty and ADC System Performance](#).

Many high performance ADCs feature differential clock inputs to simplify the task of providing the required low jitter clock on a noisy PCB. (Distributing a single-ended clock on a noisy PCB can result in coupled noise on the sample clock. Differential distribution has inherent common-mode rejection, which can provide superior clock performance in a noisy environment.)

The AD9510 features both LVPECL and LVDS outputs that provide differential clock outputs, which enable clock solutions that maximize converter SNR performance. Consider the input requirements of the ADC (differential or single-ended, logic level, termination) when selecting the best clocking/converter solution.

CMOS CLOCK DISTRIBUTION

The AD9510 provides four clock outputs (OUT4 to OUT7), which are selectable as either CMOS or LVDS levels. When selected as CMOS, these outputs provide for driving devices requiring CMOS level logic at their clock inputs.

Whenever single-ended CMOS clocking is used, follow some of the following general guidelines.

Point-to-point nets must be designed such that a driver has one receiver only on the net, if possible. This allows for simple termination schemes and minimizes ringing due to possible mismatched impedances on the net. Series termination at the source is generally required to provide transmission line matching and/or to reduce current transients at the driver. The value of the resistor is dependent on the board design and timing requirements (typically 10Ω to 100Ω is used). CMOS outputs are limited in terms of the capacitive load or trace length that they can drive. Typically, trace lengths less than 3 inches are recommended to preserve signal rise/fall times and preserve signal integrity.

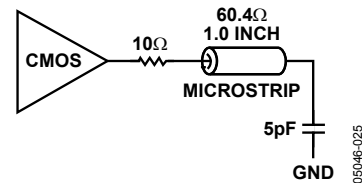

Figure 54. Series Termination of CMOS Output

Termination at the far end of the PCB trace is a second option. The CMOS outputs of the AD9510 do not supply enough current to provide a full voltage swing with a low impedance resistive, far-end termination, as shown in Figure 55. The far-end termination network must match the PCB trace impedance and provide the desired switching point. The reduced signal swing may still meet receiver input requirements in some applications. This can be useful when driving long trace lengths on less critical nets.

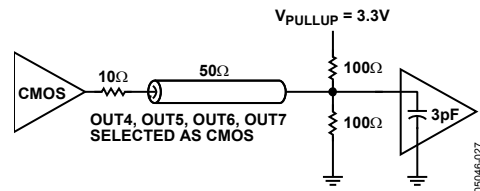

Figure 55. CMOS Output with Far-End Termination

Because of the limitations of single-ended CMOS clocking, consider using differential outputs when driving high speed signals over long traces. The AD9510 offers both LVPECL and LVDS outputs, which are better suited for driving long traces where the inherent noise immunity of differential signaling provides superior performance for clocking converters.

LVPECL CLOCK DISTRIBUTION

The low voltage, positive emitter-coupled, logic (LVPECL) outputs of the AD9510 provide the lowest jitter clock signals available from the AD9510. The LVPECL outputs (because they are open emitter) require a dc termination to bias the output transistors. A simplified equivalent circuit in Figure 41 shows the LVPECL output stage.

In most applications, a standard LVPECL far-end termination is recommended, as shown in Figure 56. The resistor network is designed to match the transmission line impedance (50 Ω) and the desired switching threshold (1.3 V).

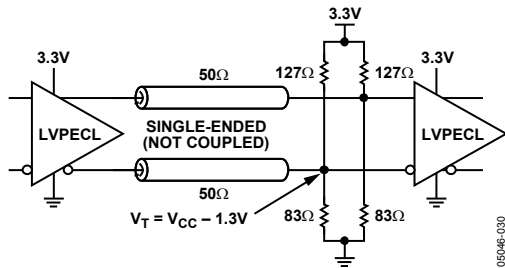

Figure 56. LVPECL Far-End Termination

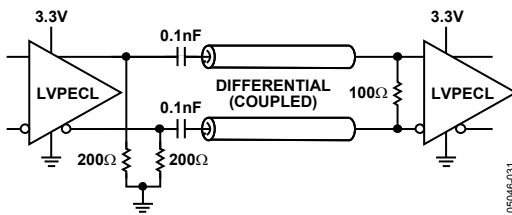

Figure 57. LVPECL with Parallel Transmission Line

LVDS CLOCK DISTRIBUTION

Low voltage differential signaling (LVDS) is a second differential output option for the AD9510. LVDS uses a current mode output stage with several user-selectable current levels. The normal value (default) for this current is 3.5 mA, which yields 350 mV output swing across a 100 Ω resistor. The LVDS outputs meet or exceed all ANSI/TIA/EIA-644 specifications.

A recommended termination circuit for the LVDS outputs is shown in Figure 58.

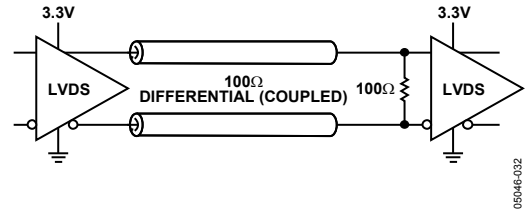

Figure 58. LVDS Output Termination

See Application Note AN-586, *LVDS Data Outputs for High-Speed Analog-to-Digital Converters*, for more information on LVDS.

POWER AND GROUNDING CONSIDERATIONS AND POWER SUPPLY REJECTION

Many applications seek high speed and performance under less than ideal operating conditions. In these application circuits, the implementation and construction of the PCB is as important as the circuit design. Proper RF techniques must be used for device selection, placement, and routing, as well as for power supply bypassing and grounding to ensure optimum performance.

OUTLINE DIMENSIONS

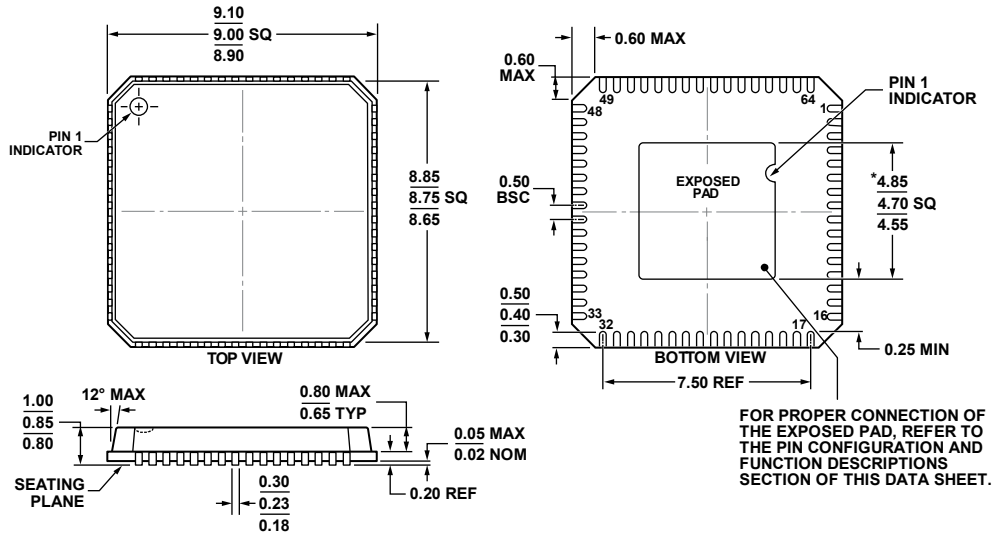

*COMPLIANT TO JEDEC STANDARDS MO-220-VMM4 EXCEPT FOR EXPOSED PAD DIMENSION

Figure 59. 64-Lead Lead Frame Chip Scale Package [LFCSP_VQ]
 9 mm × 9 mm Body, Very Thin Quad
 (CP-64-1)
 Dimensions shown in millimeters

06-13-2012-A

ORDERING GUIDE

Model ¹	Temperature Range	Package Description	Package Option
AD9510BCPZ	-40°C to +85°C	64-Lead Lead Frame Chip Scale Package [LFCSP_VQ]	CP-64-1
AD9510BCPZ-REEL7	-40°C to +85°C	64-Lead Lead Frame Chip Scale Package [LFCSP_VQ]	CP-64-1
AD9510/PCBZ		Evaluation Board Without VCO or VCXO or Loop Filter	

¹ Z = RoHS Compliant Part.

Looking for pricing, stock, or lifecycle information?

Click below to explore more details on WIN SOURCE:

 [View AD9510BCPZ on WIN SOURCE](#)

 [Analog Devices Inc. Information](#)

Optimize Your Supply Chain with WIN SOURCE Solutions

-  Global Sourcing Solution
-  Obsolete Management
-  Cost Control Management
-  Shortage Management
-  Alternative Solution
-  Excess Inventory Management