



**THE DATASHEET OF  
SN65HVD1781QDRQ1**



## SN65HVD178x-Q1 Fault-Protected RS-485 Transceivers With 3.3-V to 5-V Operation

### 1 Features

- Qualified for Automotive Applications
- AEC-Q100 Qualified With the Following Results
  - Device Temperature Grade 1:
    - 40°C to 125°C Ambient Operating Temperature Range
  - Device HBM ESD Classification Level H2
  - Device CDM ESG Classification Level C3B
- Bus-Pin Fault Protection to:
  - > ±70 V ('HVD1780-Q1, 'HVD1781-Q1)
  - > ±30 V ('HVD1782-Q1)
- Operation With 3.3-V to 5-V Supply Range
- ±16-kV HBM Protection on Bus Pins
- Reduced Unit Load for up to 320 Nodes
- Failsafe Receiver for Open-Circuit, Short-Circuit and Idle-Bus Conditions
- Low Power Consumption
  - Low Standby Supply Current, 1 μA Maximum
  - I<sub>CC</sub> 4-mA Quiescent During Operation
- Pin-Compatible With Industry-Standard SN75176
- Signaling Rates of 115 kbps, 1 Mbps, and up to 10 Mbps

### 2 Applications

Automotive Data Links

### 3 Description

These devices are designed to survive overvoltage faults such as direct shorts to power supplies, mis-wiring faults, connector failures, cable crushes, and tool mis-applications. They are also robust to ESD events, with high levels of protection to the human-body-model specification.

These devices combine a differential driver and a differential receiver, which operate from a single power supply. In the 'HVD1782, the driver differential outputs and the receiver differential inputs are connected internally to form a bus port suitable for half-duplex (two-wire bus) communication. This port features a wide common-mode voltage range, making the devices suitable for multipoint applications over long cable runs. These devices are characterized from –40°C to 125°C. These devices are pin-compatible with the industry-standard SN75176 transceiver, making them drop-in upgrades in most systems.

These devices are fully compliant with ANSI TIA/EIA 485-A with a 5-V supply and can operate with a 3.3-V supply with reduced driver output voltage for low-power applications. For applications where operation is required over an extended common-mode voltage range, see the SN65HVD1785 (SLLS872) data sheet.

#### Device Information<sup>(1)</sup>

PART NUMBER	SIGNALING RATE	NUMBER OF NODES
SN65HVD1780-Q1	Up to 115 kbps	Up to 320
SN65HVD1781-Q1	Up to 1 Mbps	Up to 320
SN65HVD1782-Q1	Up to 10 Mbps	Up to 64

(1) For all available packages, see the orderable addendum at the end of the data sheet.

#### Simplified Schematic

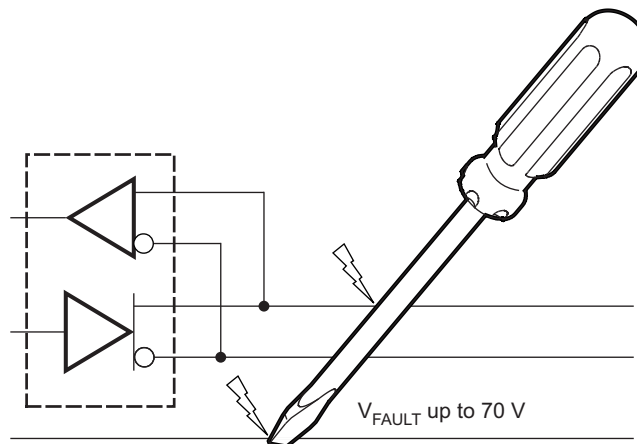

Copyright © 2016, Texas Instruments Incorporated



## Table of Contents

<b>1 Features</b> ..... 1 <b>2 Applications</b> ..... 1 <b>3 Description</b> ..... 1 <b>4 Revision History</b> ..... 2 <b>5 Pin Configuration and Functions</b> ..... 3 <b>6 Specifications</b> ..... 3 6.1 Absolute Maximum Ratings ..... 3 6.2 ESD Ratings—AEC ..... 4 6.3 ESD Ratings—IEC ..... 4 6.4 Recommended Operating Conditions ..... 4 6.5 Thermal Information ..... 4 6.6 Electrical Characteristics ..... 5 6.7 Power Dissipation Ratings ..... 6 6.8 Switching Characteristics ..... 7 6.9 Package Dissipation Ratings ..... 7 6.10 Typical Characteristics ..... 8 <b>7 Parameter Measurement Information</b> ..... 9 <b>8 Detailed Description</b> ..... 13 8.1 Overview ..... 13	8.2 Functional Block Diagram ..... 13 8.3 Feature Description ..... 13 8.4 Device Functional Modes ..... 14 <b>9 Application and Implementation</b> ..... 16 9.1 Application Information ..... 16 9.2 Typical Application ..... 16 <b>10 Power Supply Recommendations</b> ..... 20 <b>11 Layout</b> ..... 20 11.1 Layout Guidelines ..... 20 11.2 Layout Example ..... 20 <b>12 Device and Documentation Support</b> ..... 21 12.1 Device Support ..... 21 12.2 Documentation Support ..... 21 12.3 Receiving Notification of Documentation Updates ..... 21 12.4 Community Resources ..... 21 12.5 Trademarks ..... 21 12.6 Electrostatic Discharge Caution ..... 21 12.7 Glossary ..... 21 <b>13 Mechanical, Packaging, and Orderable Information</b> ..... 21
---	--

## 4 Revision History

NOTE: Page numbers for previous revisions may differ from page numbers in the current version.

Changes from Revision C (April 2016) to Revision D	Page
• Changed the differential input to receive a valid bus high from $V_{ID} < V_{IT+}$ to $V_{ID} > V_{IT+}$ in the <i>Receiver Function Table</i> .....	15
• Changed the <i>Half-Duplex Layout Example</i> .....	20
• Added the <i>Receiving Notification of Documentation Updates</i> section .....	21
• Changed the <i>Electrostatic Discharge Caution</i> statement.....	21

Changes from Revision B (January 2016) to Revision C	Page
• Changed the signaling rate for SN65HVD1780-Q1 from 115 to 0.115 Bin the <i>Recommended Operating Conditions</i> table .....	4

Changes from Revision A (August 2015) to Revision B	Page
• Changed HBM and CDM back to the AEC specification and split the IEC specification into a separate table .....	4
• Added the SN65HVD1780-Q1 and SN65HVD1782-Q1 devices to the <i>Thermal Information</i> table .....	4

Changes from Original (September 2010) to Revision A	Page
• Added <i>Pin Configuration and Functions</i> section, <i>ESD Ratings</i> table, <i>Feature Description</i> section, <i>Device Functional Modes</i> , <i>Application and Implementation</i> section, <i>Power Supply Recommendations</i> section, <i>Layout</i> section, <i>Device and Documentation Support</i> section, and <i>Mechanical, Packaging, and Orderable Information</i> section .....	1
• Added new ListItem in Features, second one with sub list items.....	1

## 5 Pin Configuration and Functions

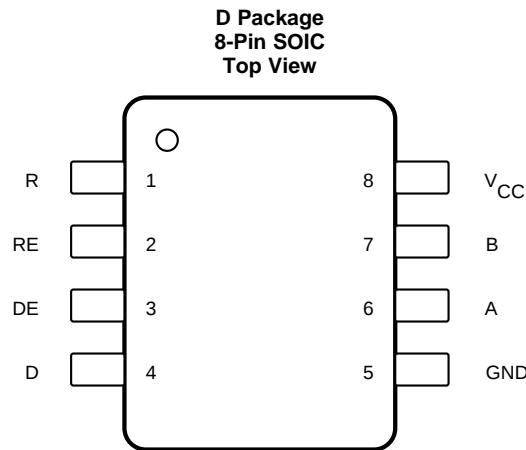

**Pin Functions**

PIN		TYPE	DESCRIPTION
NAME	NO.		
A	6	Bus I/O	Driver output or receiver input (complementary to B)
B	7	Bus I/O	Driver output or receiver input (complementary to A)
D	4	Digital input	Driver data input
DE	3	Digital input	Driver enable, active high
GND	5	Reference potential	Local device ground
R	1	Digital output	Receive data output
$\overline{RE}$	2	Digital input	Receiver enable, active low
$V_{CC}$	8	Supply	3.15-V-to-5.5-V supply

## 6 Specifications

### 6.1 Absolute Maximum Ratings

See Note <sup>(1)</sup>.

			MIN	MAX	UNIT
$V_{CC}$	Supply voltage		-0.5	7	V
Voltage range at bus pins	'HVD1780-Q1, 'HVD1781-Q1	A, B pins	-70	70	V
	'HVD1782-Q1	A, B pins	-70	30	
Input voltage range at any logic pin			-0.3	$V_{CC} + 0.3$	V
Transient overvoltage pulse through 100 $\Omega$ per T1A-485			-70	70	V
Receiver output current			-24	24	mA
Continuous total power dissipation			See <a href="#">Power Dissipation Ratings</a>		
$T_J$	Junction temperature			170	$^{\circ}\text{C}$
$T_{stg}$	Storage temperature		-40	150	$^{\circ}\text{C}$

(1) Stresses beyond those listed under *Absolute Maximum Ratings* may cause permanent damage to the device. These are stress ratings only and functional operation of the device at these or any other conditions beyond those indicated under *Recommended Operating Conditions* is not implied. Exposure to absolute-maximum-rated conditions for extended periods may affect device reliability.

## 6.2 ESD Ratings—AEC

			VALUE	UNIT	
$V_{(ESD)}$	Electrostatic discharge	Human-body model (HBM), per AEC Q100-002 <sup>(1)</sup>	Bus terminals and GND	±16000	V
			All pins	±4000	
		Charged-device model (CDM), per AEC Q100-011		±2000	
		Machine Model (MM), AEC-Q100-003		±400	

(1) AEC Q100-002 indicates that HBM stressing shall be in accordance with the ANSI/ESDA/JEDEC JS-001 specification.

## 6.3 ESD Ratings—IEC

			VALUE	UNIT	
$V_{(ESD)}$	Electrostatic discharge	Human body model (HBM), per IEC 60749-26	Bus terminals and GND	±16000	V

## 6.4 Recommended Operating Conditions

		MIN	NOM	MAX	UNIT
$V_{CC}$	Supply voltage	3.15	5	5.5	V
$V_I$	Input voltage at any bus terminal (separately or common mode) <sup>(1)</sup>	–7		12	V
$V_{IH}$	High-level input voltage (driver, driver enable, and receiver enable inputs)	2		$V_{CC}$	V
$V_{IL}$	Low-level input voltage (driver, driver enable, and receiver enable inputs)	0		0.8	V
$V_{ID}$	Differential input voltage	–12		12	V
$I_O$	Output current, driver	–60		60	mA
	Output current, receiver	–8		8	mA
$R_L$	Differential load resistance	54	60		Ω
$C_L$	Differential load capacitance		50		pF
$1/t_{UI}$	Signaling rate	SN65HVD1780-Q1		0.115	Mbps
		SN65HVD1781-Q1		1	
		SN65HVD1782-Q1		10	
$T_A$	Operating free-air temperature (See the <a href="#">Thermal Information</a> table)	5-V supply	–40	105	°C
		3.3-V supply	–40	125	
$T_J$	Junction Temperature	–40		150	°C

(1) By convention, the least positive (most negative) limit is designated as minimum in this data sheet.

## 6.5 Thermal Information

THERMAL METRIC <sup>(1)</sup>		SN65HVD1780-Q1 SN65HVD1781-Q1 SN65HVD1782-Q1		UNIT
		D (SOIC)		
		8 PINS		
$R_{\theta JA}$	Junction-to-ambient thermal resistance	JEDEC high-K model	138	°C/W
		JEDIC low-K model	242	°C/W
$R_{\theta JC(top)}$	Junction-to-case (top) thermal resistance		61	°C/W
$R_{\theta JB}$	Junction-to-board thermal resistance		62	°C/W
$\Psi_{JT}$	Junction-to-top characterization parameter		3.8	°C/W
$\Psi_{JB}$	Junction-to-board characterization parameter		38.6	°C/W
$R_{\theta JC(bot)}$	Junction-to-case (bottom) thermal resistance		N/A	°C/W

(1) For more information about traditional and new thermal metrics, see the *Semiconductor and IC Package Thermal Metrics* application report, [SPRA953](#).

## 6.6 Electrical Characteristics

over recommended operating conditions (unless otherwise noted)

PARAMETER		TEST CONDITIONS		MIN	TYP	MAX	UNIT	
V <sub>OD</sub>	Driver differential output voltage magnitude	R <sub>L</sub> = 60 Ω, 4.75 V ≤ V <sub>CC</sub> ≤ 375 Ω on each output to –7 V to 12 V, See <a href="#">Figure 6</a>	T <sub>A</sub> < 85°C	1.5			V	
			T <sub>A</sub> < 125°C	1.4				
		R <sub>L</sub> = 54 Ω, 4.75 V ≤ V <sub>CC</sub> ≤ 5.25 V	T <sub>A</sub> < 85°C	1.7	2			
			T <sub>A</sub> < 125°C	1.5				
		R <sub>L</sub> = 54 Ω, 3.15 V ≤ V <sub>CC</sub> ≤ 3.45 V		0.8	1			
R <sub>L</sub> = 100 Ω, 4.75 V ≤ V <sub>CC</sub> ≤ 5.25 V	T <sub>A</sub> < 85°C	2.2	2.5					
	T <sub>A</sub> < 125°C	2						
Δ V <sub>OD</sub>	Change in magnitude of driver differential output voltage	R <sub>L</sub> = 54 Ω		–50	0	50	mV	
V <sub>OC(SS)</sub>	Steady-state common-mode output voltage			1	V <sub>CC</sub> /2	3	V	
ΔV <sub>OC</sub>	Change in differential driver output common-mode voltage			–50	0	50	mV	
V <sub>OC(PP)</sub>	Peak-to-peak driver common-mode output voltage	Center of two 27-Ω load resistors, See <a href="#">Figure 7</a>			500		mV	
C <sub>OD</sub>	Differential output capacitance				23		pF	
V <sub>IT+</sub>	Positive-going receiver differential input voltage threshold				–100	–35	mV	
V <sub>IT–</sub>	Negative-going receiver differential input voltage threshold			–180	–150		mV	
V <sub>HYS</sub>	Receiver differential input voltage threshold hysteresis (V <sub>IT+</sub> – V <sub>IT–</sub> ) <sup>(1)</sup>			30	50		mV	
V <sub>OH</sub>	Receiver high-level output voltage	I <sub>OH</sub> = –8 mA		2.4	V <sub>CC</sub> – 0.3		V	
V <sub>OL</sub>	Receiver low-level output voltage	I <sub>OL</sub> = 8 mA	T <sub>A</sub> < 85°C		0.2	0.4	V	
			T <sub>A</sub> < 125°C			0.5		
I <sub>I(LOGIC)</sub>	Driver input, driver enable, and receiver enable input current			–50		50	μA	
I <sub>OZ</sub>	Receiver output high-impedance current	V <sub>O</sub> = 0 V or V <sub>CC</sub> , RE at V <sub>CC</sub>		–1		1	μA	
I <sub>OS</sub>	Driver short-circuit output current			–200		200	mA	
I <sub>I(BUS)</sub>	Bus input current (disabled driver)	V <sub>CC</sub> = 3.15 to 5.5 V or V <sub>CC</sub> = 0 V, DE at 0 V	V <sub>I</sub> = 12 V	HVD1780-Q1, HVD1781-Q1		75	100	μA
				HVD1782-Q1		400	500	
			V <sub>I</sub> = –7 V	HVD1780-Q1, HVD1781-Q1	–60	–40		
				HVD1782-Q1	–400	–300		
I <sub>CC</sub>	Supply current (quiescent)	Driver and receiver enabled	DE = V <sub>CC</sub> , RE = GND, no load		4	6	mA	
			Driver enabled, receiver disabled	DE = V <sub>CC</sub> , RE = V <sub>CC</sub> , no load		3		5
			Driver disabled, receiver enabled	DE = GND, RE = GND, no load		2		4
		Driver and receiver disabled, standby mode	DE = GND, D = open, RE = V <sub>CC</sub> , no load, T <sub>A</sub> < 85°C		0.15	1	μA	
			DE = GND, D = open, RE = V <sub>CC</sub> , no load, T <sub>A</sub> < 125°C			12		
Supply current (dynamic)		See the <a href="#">Typical Characteristics</a> section						

(1) Ensured by design. Not production tested.

## 6.7 Power Dissipation Ratings

PARAMETER	TEST CONDITIONS	VALUE	UNIT
P <sub>D</sub> Power dissipation	V <sub>CC</sub> = 3.6 V, T <sub>J</sub> = 150°C, R <sub>L</sub> = 300 Ω, C <sub>L</sub> = 50 pF (driver), C <sub>L</sub> = 15 pF (receiver) 3.3-V supply, unterminated <sup>(1)</sup>	75	mW
	V <sub>CC</sub> = 3.6 V, T <sub>J</sub> = 150°C, R <sub>L</sub> = 100 Ω, C <sub>L</sub> = 50 pF (driver), C <sub>L</sub> = 15 pF (receiver) 3.3-V supply, RS-422 load <sup>(1)</sup>	95	
	V <sub>CC</sub> = 3.6 V, T <sub>J</sub> = 150°C, R <sub>L</sub> = 54 Ω, C <sub>L</sub> = 50 pF (driver), C <sub>L</sub> = 15 pF (receiver) 3.3-V supply, RS-485 load <sup>(1)</sup>	115	
	V <sub>CC</sub> = 5.5 V, T <sub>J</sub> = 150°C, R <sub>L</sub> = 300 Ω, C <sub>L</sub> = 50 pF (driver), C <sub>L</sub> = 15 pF (receiver) 5-V supply, unterminated <sup>(1)</sup>	290	
	V <sub>CC</sub> = 5.5 V, T <sub>J</sub> = 150°C, R <sub>L</sub> = 100 Ω, C <sub>L</sub> = 50 pF (driver), C <sub>L</sub> = 15 pF (receiver) 5-V supply, RS-422 load <sup>(1)</sup>	320	
	V <sub>CC</sub> = 5.5 V, T <sub>J</sub> = 150°C, R <sub>L</sub> = 54 Ω, C <sub>L</sub> = 50 pF (driver), C <sub>L</sub> = 15 pF (receiver) 5-V supply, RS-485 load <sup>(1)</sup>	400	
T <sub>SD</sub> Thermal-shutdown junction temperature		170	°C

(1) Driver and receiver enabled, 50% duty cycle square-wave signal at signaling rate: 1 Mbps.

## 6.8 Switching Characteristics

over recommended operating conditions (unless otherwise noted)

PARAMETER		TEST CONDITIONS		MIN	TYP	MAX	UNIT
<b>DRIVER (SN65HVD1780)</b>							
$t_r, t_f$	Driver differential output rise/fall time	$R_L = 54 \Omega$ , $C_L = 50 \text{ pF}$ , See <a href="#">Figure 8</a>	$3.15 \text{ V} < V_{CC} < 3.45 \text{ V}$	0.4	1.4	1.8	$\mu\text{s}$
			$3.15 \text{ V} < V_{CC} < 5.5 \text{ V}$	0.4	1.7	2.6	$\mu\text{s}$
$t_{PHL}, t_{PLH}$	Driver propagation delay	$R_L = 54 \Omega, C_L = 50 \text{ pF}$ , See <a href="#">Figure 8</a>			0.8	2	$\mu\text{s}$
$t_{SK(P)}$	Driver differential output pulse skew, $ t_{PHL} - t_{PLH} $	$R_L = 54 \Omega, C_L = 50 \text{ pF}$ , See <a href="#">Figure 8</a>			20	250	ns
$t_{PHZ}, t_{PLZ}$	Driver disable time	See <a href="#">Figure 9</a> and <a href="#">Figure 10</a>			0.1	5	$\mu\text{s}$
$t_{PZH}, t_{PZL}$	Driver enable time	Receiver enabled	See <a href="#">Figure 9</a> and <a href="#">Figure 10</a>		0.2	3	$\mu\text{s}$
		Receiver disabled		3	12		
<b>DRIVER (SN65HVD1781)</b>							
$t_r, t_f$	Driver differential output rise/fall time	$R_L = 54 \Omega, C_L = 50 \text{ pF}$ , See <a href="#">Figure 8</a>		50		300	ns
$t_{PHL}, t_{PLH}$	Driver propagation delay	$R_L = 54 \Omega, C_L = 50 \text{ pF}$ , See <a href="#">Figure 8</a>				200	ns
$t_{SK(P)}$	Driver differential output pulse skew, $ t_{PHL} - t_{PLH} $	$R_L = 54 \Omega, C_L = 50 \text{ pF}$ , See <a href="#">Figure 8</a>				25	ns
$t_{PHZ}, t_{PLZ}$	Driver disable time	See <a href="#">Figure 9</a> and <a href="#">Figure 10</a>				3	$\mu\text{s}$
$t_{PZH}, t_{PZL}$	Driver enable time	Receiver enabled	See <a href="#">Figure 9</a> and <a href="#">Figure 10</a>			300	ns
		Receiver disabled		10	$\mu\text{s}$		
<b>DRIVER (SN65HVD1782)</b>							
$t_r, t_f$	Driver differential output rise/fall time	$R_L = 54 \Omega$ , $C_L = 50 \text{ pF}$	All $V_{CC}$ and Temp			50	ns
			$V_{CC} > 4.5 \text{ V}$ and $T < 105^\circ\text{C}$		16		
$t_{PHL}, t_{PLH}$	Driver propagation delay	$R_L = 54 \Omega, C_L = 50 \text{ pF}$ , See <a href="#">Figure 8</a>				55	ns
$t_{SK(P)}$	Driver differential output pulse skew, $ t_{PHL} - t_{PLH} $	$R_L = 54 \Omega, C_L = 50 \text{ pF}$ , See <a href="#">Figure 8</a>				10	ns
$t_{PHZ}, t_{PLZ}$	Driver disable time	See <a href="#">Figure 9</a> and <a href="#">Figure 10</a>				3	$\mu\text{s}$
$t_{PZH}, t_{PZL}$	Driver enable time	Receiver enabled	See <a href="#">Figure 9</a> and <a href="#">Figure 10</a>			300	ns
		Receiver disabled		9	$\mu\text{s}$		
<b>RECEIVER (ALL DEVICES UNLESS OTHERWISE NOTED)</b>							
$t_r, t_f$	Receiver output rise/fall time <sup>(1)</sup>	$C_L = 15 \text{ pF}$ , See <a href="#">Figure 11</a>	All devices		4	15	ns
$t_{PHL}, t_{PLH}$	Receiver propagation delay time	$C_L = 15 \text{ pF}$ , See <a href="#">Figure 11</a>	HVD1780-Q1, HVD1781-Q1		100	200	ns
			HVD1782-Q1			80	
$t_{SK(P)}$	Receiver output pulse skew, $ t_{PHL} - t_{PLH} $	$C_L = 15 \text{ pF}$ , See <a href="#">Figure 11</a>	HVD1780-Q1, HVD1781-Q1		6	20	ns
			HVD1782-Q1			5	
$t_{PLZ}, t_{PHZ}$	Receiver disable time <sup>(1)</sup>	Driver enabled, See <a href="#">Figure 12</a>			15	100	ns
$t_{PZL(1)}, t_{PZH(1)}$ $t_{PZL(2)}, t_{PZH(2)}$	Receiver enable time	Driver enabled, See <a href="#">Figure 12</a>			80	300	ns
		Driver disabled, See <a href="#">Figure 13</a>			3	9	$\mu\text{s}$

(1) Ensured by design. Not production tested.

## 6.9 Package Dissipation Ratings

PACKAGE <sup>(1)</sup>	JEDEC THERMAL MODEL	$T_A < 25^\circ\text{C}$ RATING	DERATING FACTOR ABOVE $T_A = 25^\circ\text{C}$	$T_A = 85^\circ\text{C}$ RATING	$T_A = 105^\circ\text{C}$ RATING	$T_A = 125^\circ\text{C}$ RATING (3.3 V ONLY)
SOIC (D) 8-pin	High-K	905 mW	7.25 mW/ $^\circ\text{C}$	470 mW	325 mW	180 mW
	Low-K	516 mW	4.1 mW/ $^\circ\text{C}$	268 mW	186 mW	103 mW

(1) For the most current package and ordering information, see the [Mechanical, Packaging, and Orderable Information](#) section, or see the TI website at [www.ti.com](http://www.ti.com).

## 6.10 Typical Characteristics

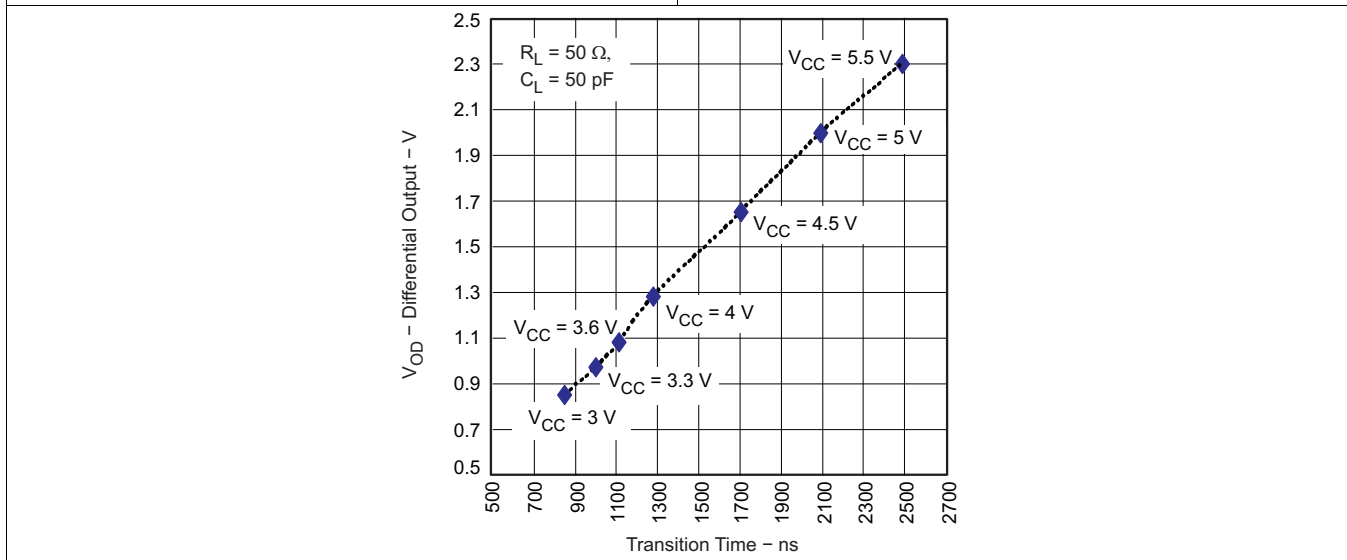
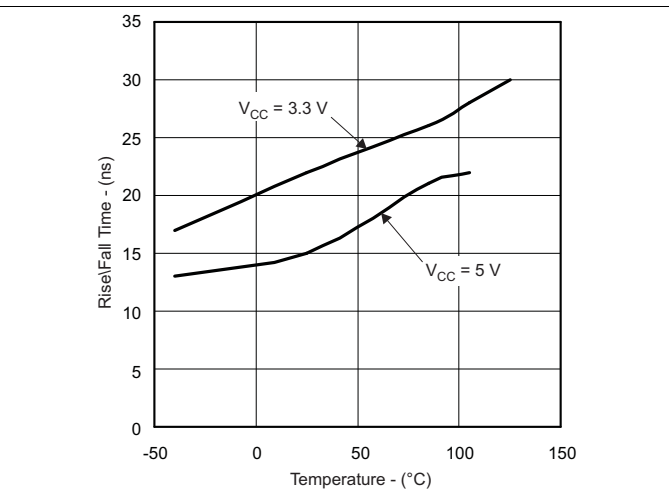
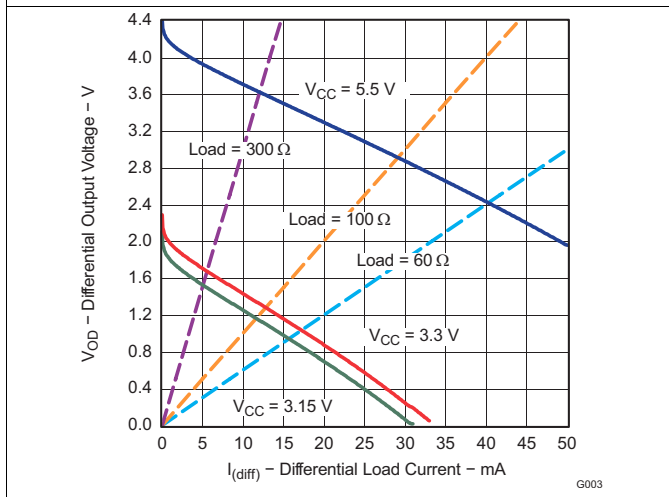
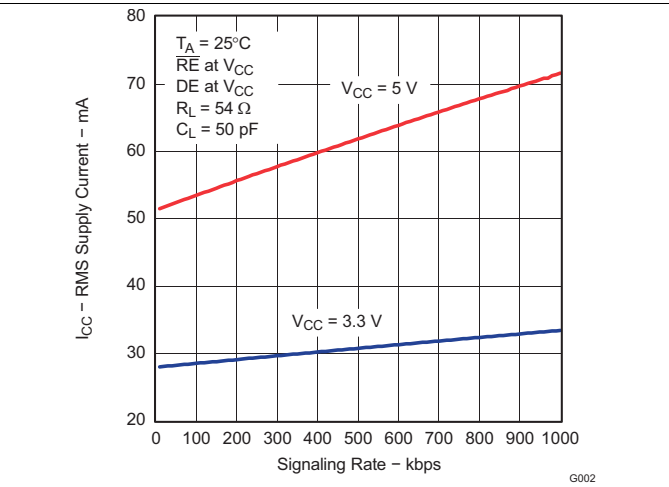
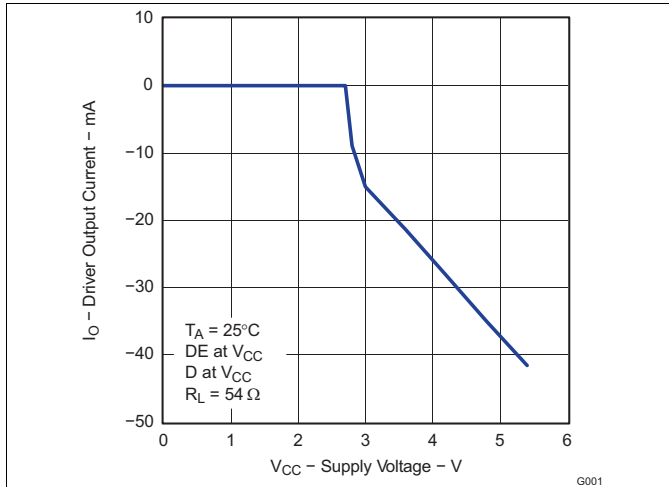

## 7 Parameter Measurement Information

Input generator rate is 100 kbps, 50% duty cycle, rise and fall times less than 6 ns, output impedance 50 Ω.

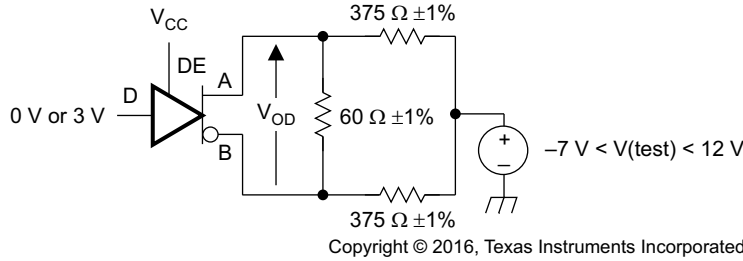

Figure 6. Measurement of Driver Differential Output Voltage With Common-Mode Load

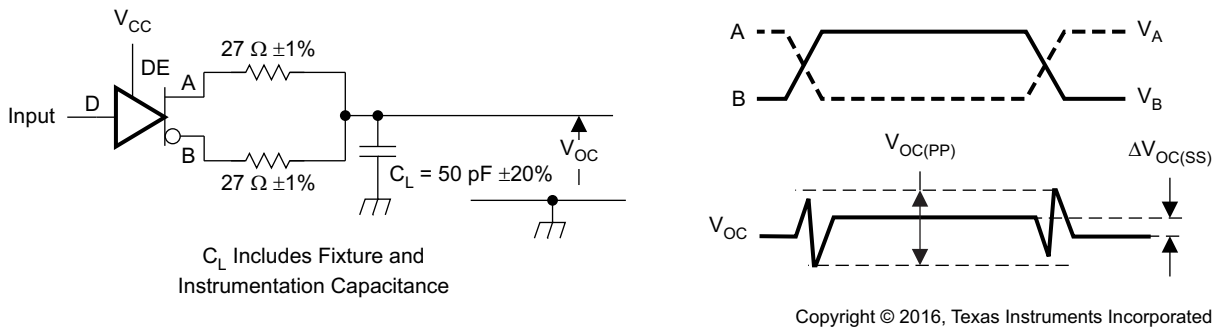

Figure 7. Measurement of Driver Differential and Common-Mode Output With RS-485 Load

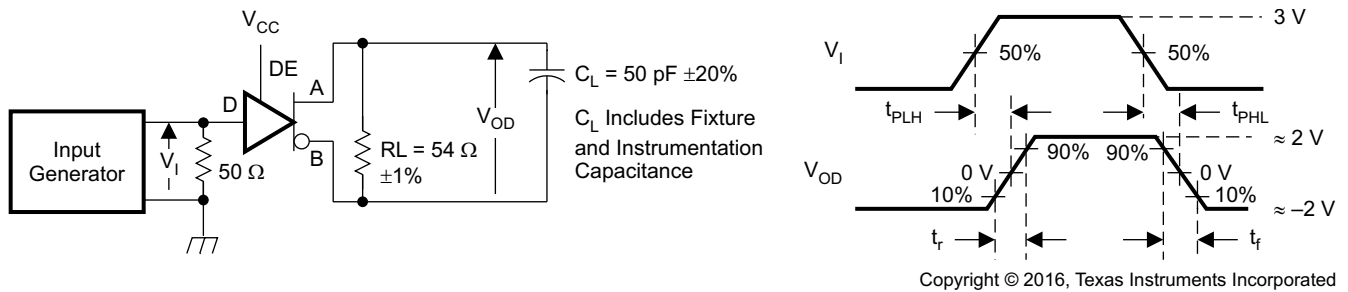
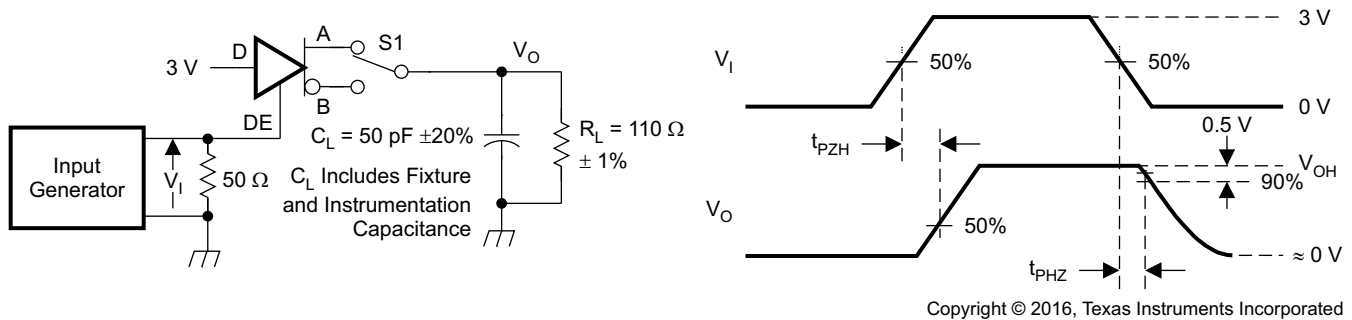

Figure 8. Measurement of Driver Differential Output Rise and Fall Times and Propagation Delays



NOTE: D at 3 V to test non-inverting output, D at 0 V to test inverting output.

Figure 9. Measurement of Driver Enable and Disable Times With Active High Output and Pulldown Load

Parameter Measurement Information (continued)

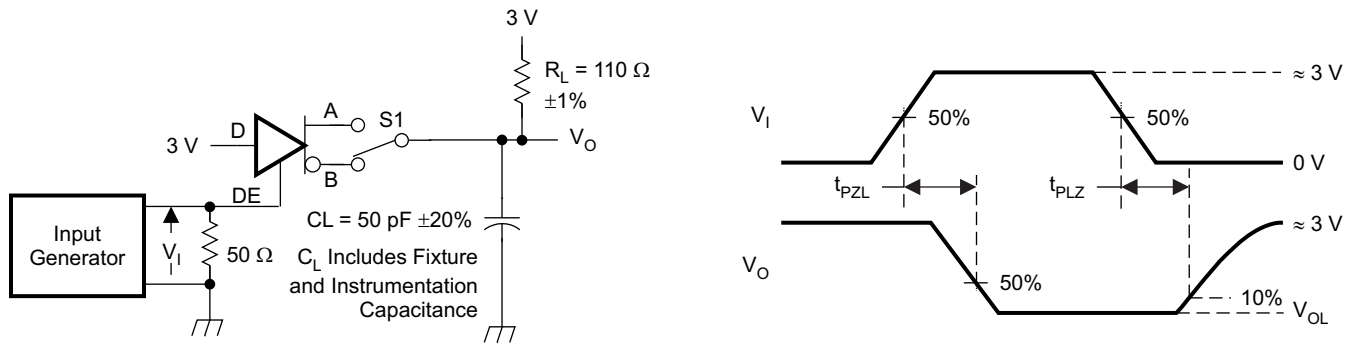

Copyright © 2016, Texas Instruments Incorporated

NOTE: D at 0 V to test non-inverting output, D at 3 V to test inverting output.

Figure 10. Measurement of Driver Enable and Disable Times With Active-Low Output and Pullup Load

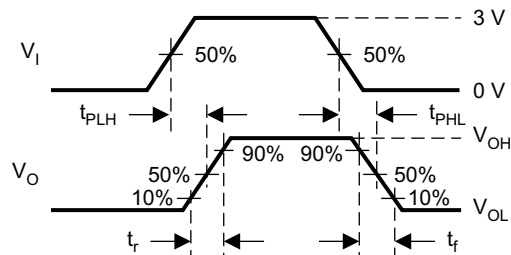
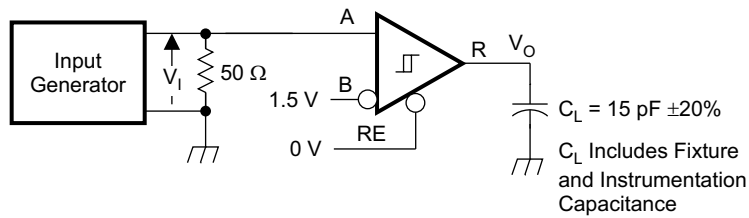

Copyright © 2016, Texas Instruments Incorporated

Figure 11. Measurement of Receiver Output Rise and Fall Times and Propagation Delays

Parameter Measurement Information (continued)

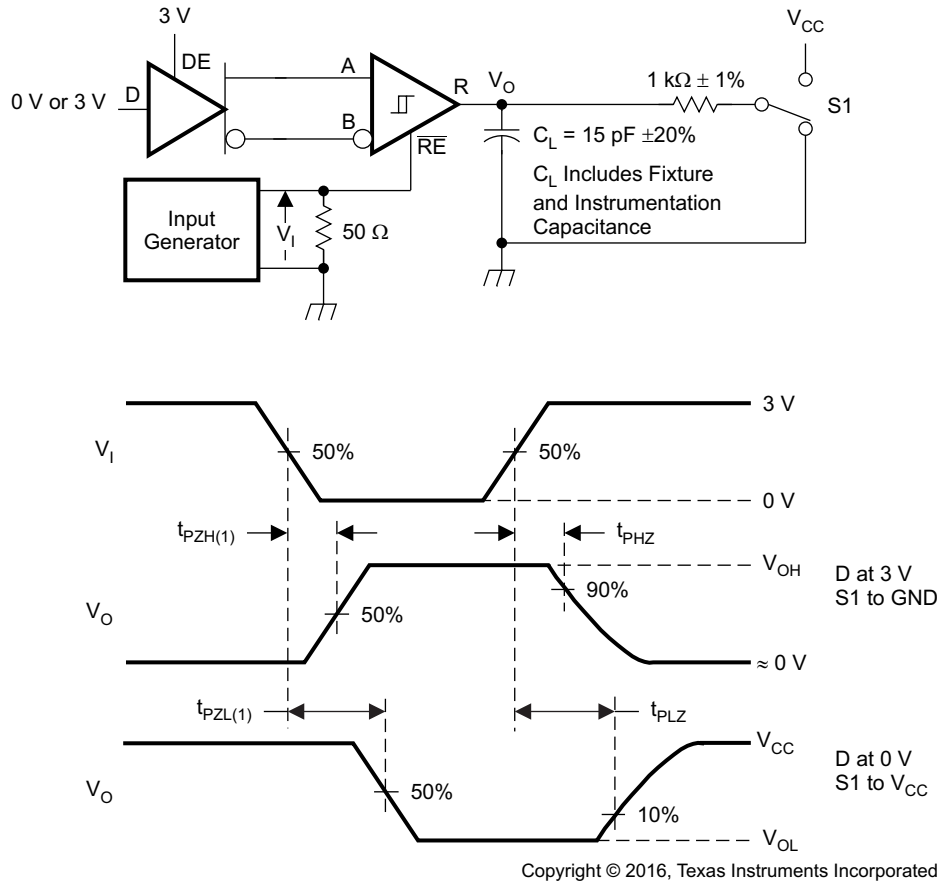

Figure 12. Measurement of Receiver Enable and Disable Times With Driver Enabled

Parameter Measurement Information (continued)

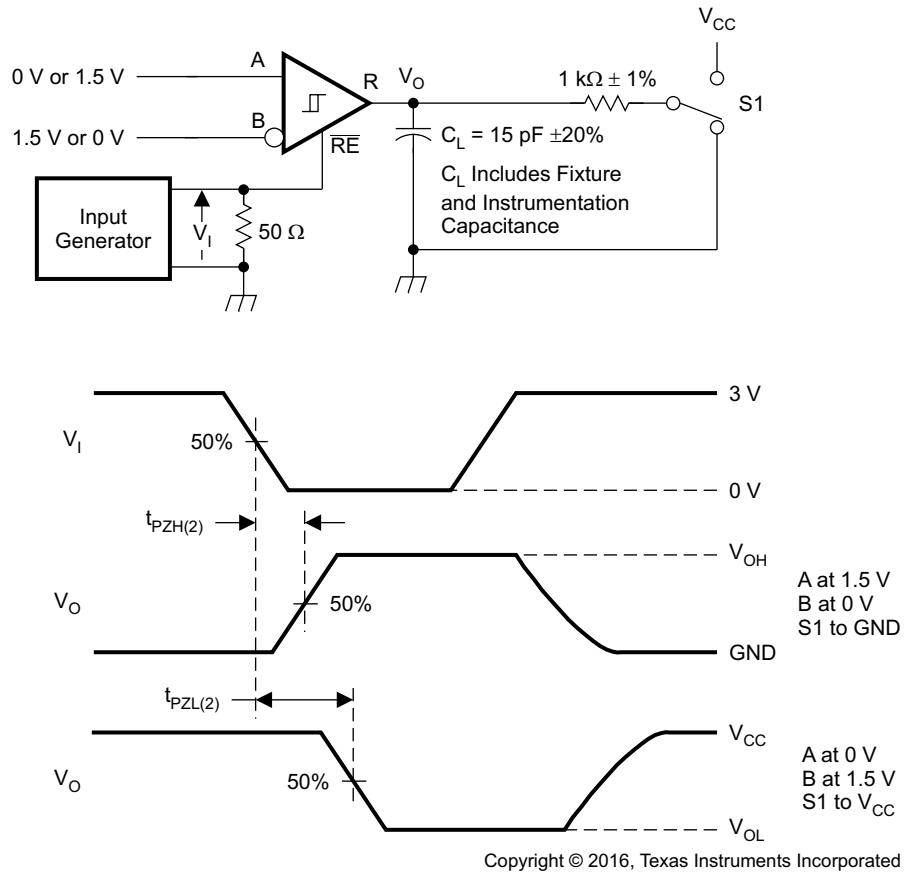

Figure 13. SN65HVD1781 Measurement of Receiver Enable Times With Driver Disabled

## 8 Detailed Description

### 8.1 Overview

The SN65HVD1780-Q1, SN65HVD1781-Q1, and SN65HVD1782-Q1 devices are half-duplex RS-485 transceivers available in three speed grades suitable for data transmission up to 115 kbps, 1 Mbps, and 10 Mbps.

These devices feature a wide common-mode operating range and bus-pin fault protection up to  $\pm 70$  V. Each device has an active-high driver enable and active-low receiver enable. A standby current of less than  $1 \mu\text{A}$  can be achieved by disabling both driver and receiver.

### 8.2 Functional Block Diagram

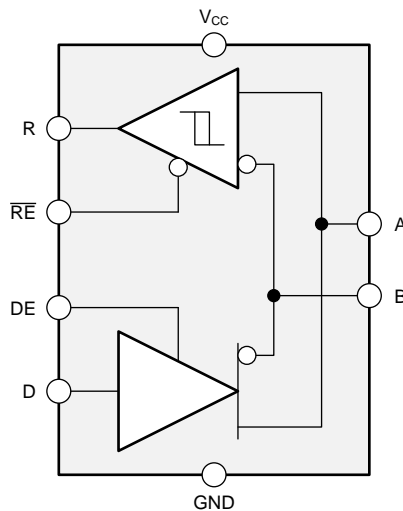

Copyright © 2016, Texas Instruments Incorporated

### 8.3 Feature Description

Internal ESD protection circuits protect the transceiver bus terminals against  $\pm 16$ -kV Human Body Model (HBM) electrostatic discharges.

Device operation is specified over a wide temperature range from  $-40^{\circ}\text{C}$  to  $125^{\circ}\text{C}$ .

#### 8.3.1 Bus Fault Conditions

The SN65HVD178x-Q1 family of RS-485 transceivers is designed to survive bus pin faults up to  $\pm 70$  V. The SN65HVD1782-Q1 device will not survive a bus pin fault with a direct short to voltages above 30 V when all of the following occurs:

- The device is powered on
- The driver is enabled ( $\text{DE} = \text{HIGH}$ ), and one of the following is true
  - $\text{D} = \text{HIGH}$  AND the bus fault is applied to the A pin
  - $\text{D} = \text{LOW}$  AND the bus fault is applied to the B pin

## Feature Description (continued)

Under other conditions, the device survives shorts to bus pin faults up to  $\pm 70$  V. [Table 1](#) summarizes the conditions under which the device may be damaged, and the conditions under which the device will not be damaged.

**Table 1. Bus Fault Conditions for the HVD1782**

POWER	DE	D	A	B	RESULTS
OFF	X	X	$-70\text{ V} < V_A < 70\text{ V}$	$-70\text{ V} < V_B < 70\text{ V}$	Device survives
ON	LO	X	$-70\text{ V} < V_A < 70\text{ V}$	$-70\text{ V} < V_B < 70\text{ V}$	Device survives
ON	HI	L	$-70\text{ V} < V_A < 70\text{ V}$	$-70\text{ V} < V_B < 30\text{ V}$	Device survives
ON	HI	L	$-70\text{ V} < V_A < 70\text{ V}$	$30\text{ V} < V_B$	Damage may occur
ON	HI	H	$-70\text{ V} < V_A < 30\text{ V}$	$-70\text{ V} < V_B < 30\text{ V}$	Device survives
ON	HI	H	$30\text{ V} < V_A$	$-70\text{ V} < V_B < 30\text{ V}$	Damage may occur

### 8.3.2 Receiver Failsafe

The SN65HVD178x-Q1 family of half-duplex transceivers provides internal biasing of the receiver input thresholds in combination with large input-threshold hysteresis. At a positive input threshold of  $V_{IT+} = -35$  mV and an input hysteresis of  $V_{HYS} = 30$  mV, the receiver output remains logic high under bus-idle, bus-short, or open bus conditions in the presence of up to 130-mV<sub>PP</sub> differential noise without the need for external failsafe biasing resistors.

### 8.3.3 Hot-Plugging

These devices are designed to operate in *hot swap* or *hot-pluggable* applications. Key features for hot-pluggable applications are power-up and power-down glitch free operation, default disabled input and output pins, and receiver failsafe.

As shown in the [Functional Block Diagram](#), an internal power-on reset circuit keeps the driver outputs in a high impedance state until the supply voltage has reached a level at which the device will reliably operate. This circuit ensures that no problems occur on the bus pin outputs as the power supply turns on or off.

As shown in [Device Functional Modes](#), the driver and receiver enable inputs (DE and  $\overline{RE}$ ) are disabled by default. This default ensures that the device neither drives the bus nor reports data on the R pin until the associated controller actively drivers the enable pins.

## 8.4 Device Functional Modes

When the driver enable pin, DE, is logic high, the differential outputs A and B follow the logic states at data input D. A logic high at D causes A to turn high and B to turn low. In this case the differential output voltage defined as  $V_{OD} = V_A - V_B$  is positive. When D is low, the output states reverse, B turns high, A becomes low, and  $V_{OD}$  is negative.

When DE is low, both outputs turn high-impedance. In this condition the logic state at D is irrelevant. The DE pin has an internal pull-down resistor to ground, thus when left open the driver is disabled (high-impedance) by default. The D pin has an internal pull-up resistor to  $V_{CC}$ , thus, when left open while the driver is enabled, output A turns high and B turns low.

**Table 2. Driver Function Table**

INPUT	ENABLE	OUTPUTS		DRIVER STATE
		A	B	
H	H	H	L	Actively drive bus High
L	H	L	H	Actively drive bus Low
X	L	Z	Z	Driver disabled
X	OPEN	Z	Z	Driver disabled by default
OPEN	H	H	L	Actively drive bus High by default

When the receiver enable pin,  $\overline{RE}$ , is logic low, the receiver is enabled. When the differential input voltage defined as  $V_{ID} = V_A - V_B$  is positive and higher than the positive input threshold,  $V_{IT+}$ , the receiver output, R, turns high. When  $V_{ID}$  is negative and lower than the negative input threshold,  $V_{IT-}$ , the receiver output, R, turns low. If  $V_{ID}$  is between  $V_{IT+}$  and  $V_{IT-}$  the output is indeterminate.

When  $\overline{RE}$  is logic high or left open, the receiver output is high-impedance and the magnitude and polarity of  $V_{ID}$  are irrelevant. Internal biasing of the receiver inputs causes the output to go failsafe-high when the transceiver is disconnected from the bus (open-circuit), the bus lines are shorted (short-circuit), or the bus is not actively driven (idle bus).

**Table 3. Receiver Function Table**

DIFFERENTIAL INPUT	ENABLE	OUTPUT	RECEIVER STATE
$V_{ID} = V_A - V_B$	$\overline{RE}$	R	
$V_{ID} > V_{IT+}$	L	H	Receive valid bus High
$V_{IT-} < V_{ID} < V_{IT+}$	L	?	Indeterminate bus state
$V_{ID} < V_{IT-}$	L	L	Receive valid bus Low
X	H	Z	Receiver disabled
X	OPEN	Z	Receiver disabled by default
Open-circuit bus	L	H	Fail-safe high output
Short-circuit bus	L	H	Fail-safe high output
Idle (terminated) bus	L	H	Fail-safe high output

## 9 Application and Implementation

### NOTE

Information in the following applications sections is not part of the TI component specification, and TI does not warrant its accuracy or completeness. TI's customers are responsible for determining suitability of components for their purposes. Customers should validate and test their design implementation to confirm system functionality.

### 9.1 Application Information

The SN65HVD178x-Q1 family of devices is a half-duplex RS-485 transceiver commonly used for asynchronous data transmissions. The driver and receiver enable pins allow for the configuration of different operating modes.

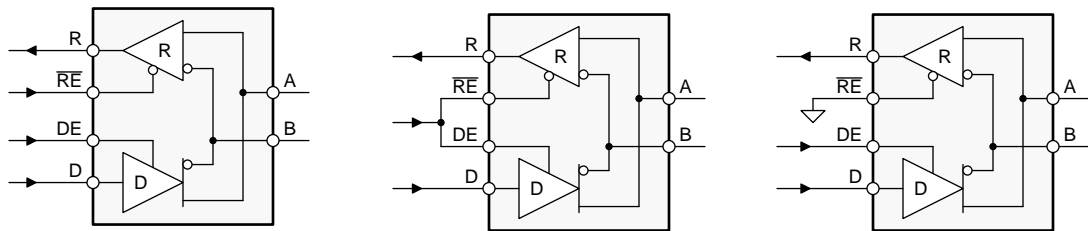

Copyright © 2016, Texas Instruments Incorporated

**Figure 14. Half-Duplex Transceiver Configurations**

Using independent enable lines provides the most flexible control as it allows for the driver and the receiver to be turned on and off individually. While this configuration requires two control lines, it allows for selective listening into the bus traffic, whether the driver is transmitting data or not.

Combining the enable signals simplifies the interface to the controller by forming a single direction-control signal. In this configuration, the transceiver operates as a driver when the direction-control line is high, and as a receiver when the direction-control line is low.

Additionally, only one line is required when connecting the receiver-enable input to ground and controlling only the driver-enable input. In this configuration, a node not only receives the data from the bus, but also the data it sends and can verify that the correct data have been transmitted.

### 9.2 Typical Application

An RS-485 bus consists of multiple transceivers connecting in parallel to a bus cable. To eliminate line reflections, each cable end is terminated with a termination resistor,  $R_T$ , whose value matches the characteristic impedance,  $Z_0$ , of the cable. This method, known as parallel termination, allows for higher data rates over longer cable length.

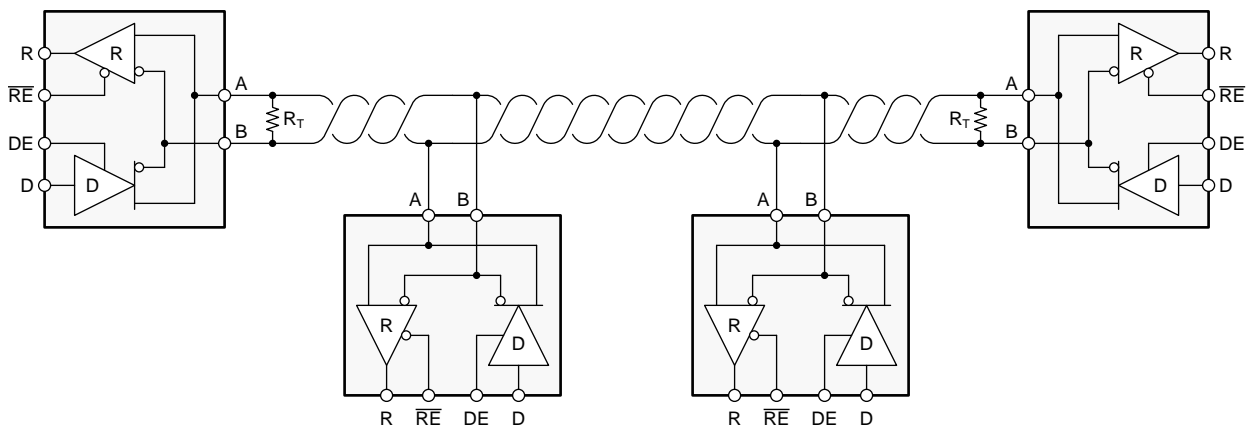

Copyright © 2016, Texas Instruments Incorporated

**Figure 15. Typical RS-485 Network With Half-Duplex Transceivers**

## Typical Application (continued)

### 9.2.1 Design Requirements

RS-485 is a robust electrical standard suitable for long-distance networking that may be used in a wide range of applications with varying requirements, such as distance, data rate, and number of nodes.

#### 9.2.1.1 Data Rate and Bus Length

There is an inverse relationship between data rate and bus length, meaning the higher the data rate, the shorter the cable length; and conversely, the lower the data rate, the longer the cable may be without introducing data errors. While most RS-485 systems use data rates between 10 kbps and 100 kbps, some applications require data rates up to 250 kbps at distances of 4000 feet and longer. Longer distances are possible by allowing for small signal jitter of up to 5 or 10%.

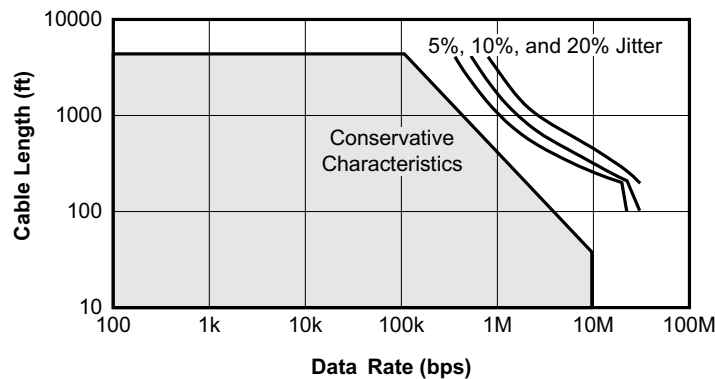

Figure 16. Cable Length vs Data Rate Characteristic

#### 9.2.1.2 Bus Loading

The RS-485 standard specifies that a compliant driver must be able to driver 32 unit loads (UL), where 1 unit load represents a load impedance of approximately 12 kΩ. Because the SN65HVD7x-Q1 family of devices consists of 1/10 UL transceivers, it is possible to connect up to 320 receivers to the bus.

### 9.2.2 Detailed Design Procedure

Although the SN65HVD178x-Q1 family of devices is internally protected against human-body-model ESD strikes up to 16 kV, additional protection against higher-energy transients can be provided at the application level by implementing external protection devices.

Figure 17 shows a protection circuit intended to withstand 8-kV IEC ESD (per IEC 61000-4-2) as well as 4-kV EFT (per IEC 61000-4-4).

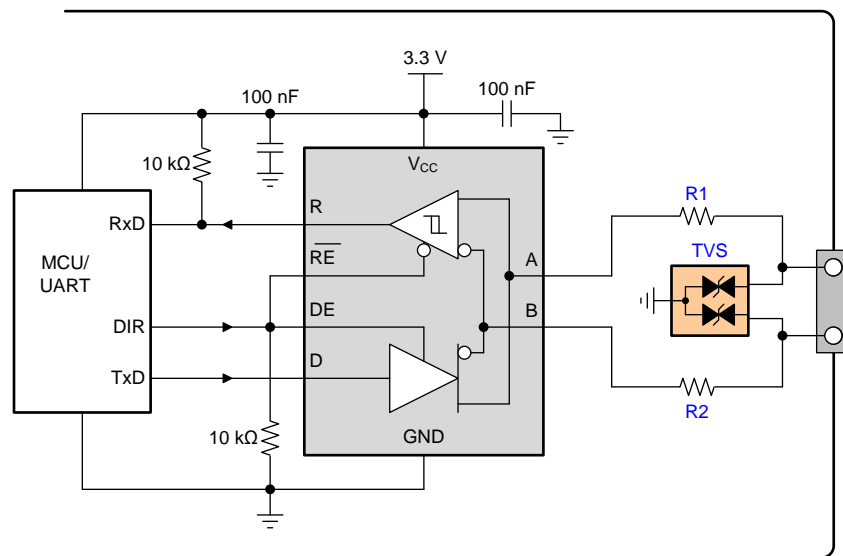
**Typical Application (continued)**

Copyright © 2016, Texas Instruments Incorporated

**Figure 17. RS-485 Transceiver with External Transient Protection**
**Table 4. Bill of Materials**

DEVICE	FUNCTION	ORDER NUMBER	MANUFACTURER
XCVR	RS-485 Transceiver	SN65HVD178x-Q1	TI
R1, R2	10-Ω, Pulse-Proof Thick-Film Resistor	CRCW0603010RJNEAHP	Vishay
TVS	Bidirectional 600-W Transient Suppressor	SMBJ43CA	Littlefuse

**9.2.2.1 Stub Length**

When connecting a node to the bus, the distance between the transceiver inputs and the cable trunk, known as the stub, should be as short as possible. Stubs present a non-terminated piece of bus line which can introduce reflections as the length of the stub increases. As a general guideline, the electrical length, or round-trip delay, of a stub should be less than one-tenth of the rise time of the driver, thus giving a maximum physical stub length as shown in [Equation 1](#).

$$L_{\text{stub}} \leq 0.1 \times t_r \times v \times c$$

where

- $t_r$  is the 10/90 rise time of the driver
- $c$  is the speed of light ( $3 \times 10^8$  m/s)
- $v$  is the signal velocity of the cable or trace as a factor of  $c$

(1)

**9.2.2.2 Receiver Failsafe**

The differential receivers of the SN65HVD178x-Q1 family have receiver input thresholds that are offset so that receiver output state is known for the following three fault conditions:

- Open bus conditions, such as a disconnected connector
- Shorted bus conditions, such as cable damage shorting the twisted-pair together
- Idle bus conditions that occur when no driver on the bus is actively driving

In any of these cases, the differential receiver will output a failsafe logic High state so that the output of the receiver is not indeterminate.

Receiver failsafe is accomplished by offsetting the receiver thresholds such that the *input indeterminate* range does not include zero volts differential. In order to comply with the RS-422 and RS-485 standards, the receiver output must output a High when the differential input  $V_{ID}$  is more positive than 200 mV, and must output a Low when  $V_{ID}$  is more negative than  $-200$  mV. The receiver parameters which determine the failsafe performance are  $V_{IT(+)}$ ,  $V_{IT(-)}$ , and  $V_{HYS}$  (the separation between  $V_{IT(+)}$  and  $V_{IT(-)}$ ). As shown in the [Electrical Characteristics](#) table, differential signals more negative than  $-200$  mV will always cause a Low receiver output, and differential signals more positive than 200 mV will always cause a High receiver output.

When the differential input signal is close to zero, it is still above the maximum  $V_{IT(+)}$  threshold of  $-35$  mV, and the receiver output will be High. Only when the differential input is more than  $V_{HYS}$  below  $V_{IT(+)}$  will the receiver output transition to a Low state. Therefore, the noise immunity of the receiver inputs during a bus fault condition includes the receiver hysteresis value,  $V_{HYS}$ , as well as the value of  $V_{IT(+)}$ .

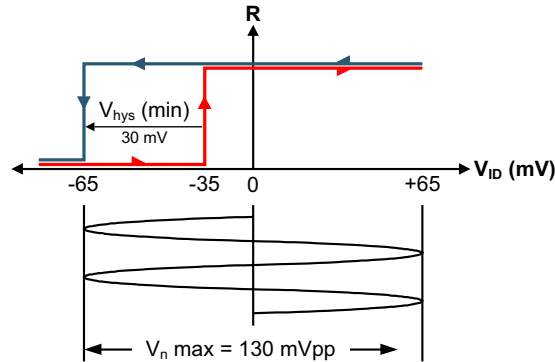
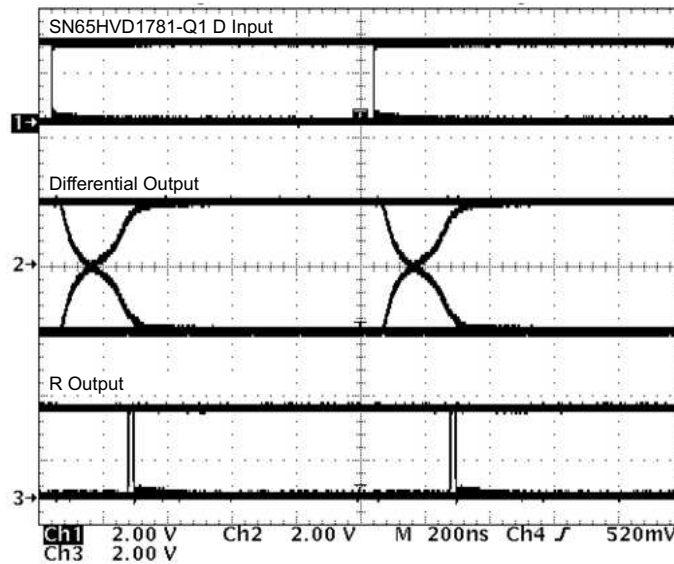

Figure 18. Noise Immunity Under Bus Fault Conditions

### 9.2.3 Application Curve



1-Mbps Operation

Figure 19. SN65HVD1781-Q1 PRBS Data Pattern

## 10 Power Supply Recommendations

To ensure reliable operation at all data rates and supply voltages, each supply should be buffered with a 100-nF ceramic capacitor located as close to the supply pins as possible. The TPS7A6150-Q1 is a linear voltage regulator suitable for the 5-V supply.

## 11 Layout

### 11.1 Layout Guidelines

On-chip IEC-ESD protection is good for laboratory and portable equipment but often insufficient for EFT and surge transients occurring in industrial environments. Therefore robust and reliable bus node design requires the use of external transient protection devices.

Because ESD and EFT transients have a wide frequency bandwidth from approximately 3 MHz to 3 GHz, high-frequency layout techniques must be applied during PCB design.

1. Place the protection circuitry close to the bus connector to prevent noise transients from entering the board.
2. Use  $V_{CC}$  and ground planes to provide low-inductance. High-frequency currents follow the path of least inductance and not the path of least impedance.
3. Design the protection components into the direction of the signal path. Do not force the transient currents to divert from the signal path to reach the protection device.
4. Apply 100-nF to 220-nF bypass capacitors as close as possible to the  $V_{CC}$  pins of the transceiver, UART, or controller ICs on the board.
5. Use at least two vias for  $V_{CC}$  and ground connections of bypass capacitors and protection devices to minimize effective via inductance.
6. Use 1-k $\Omega$  to 10-k $\Omega$  pullup and pulldown resistors for enable lines to limit noise currents in these lines during transient events.
7. While pure TVS protection is sufficient for surge transients up to 1 kV, higher transients require metal-oxide varistors (MOVs) which reduce the transients to a few hundred volts of clamping voltage, and transient blocking units (TBUs) that limit transient current to less than 1 mA.

### 11.2 Layout Example

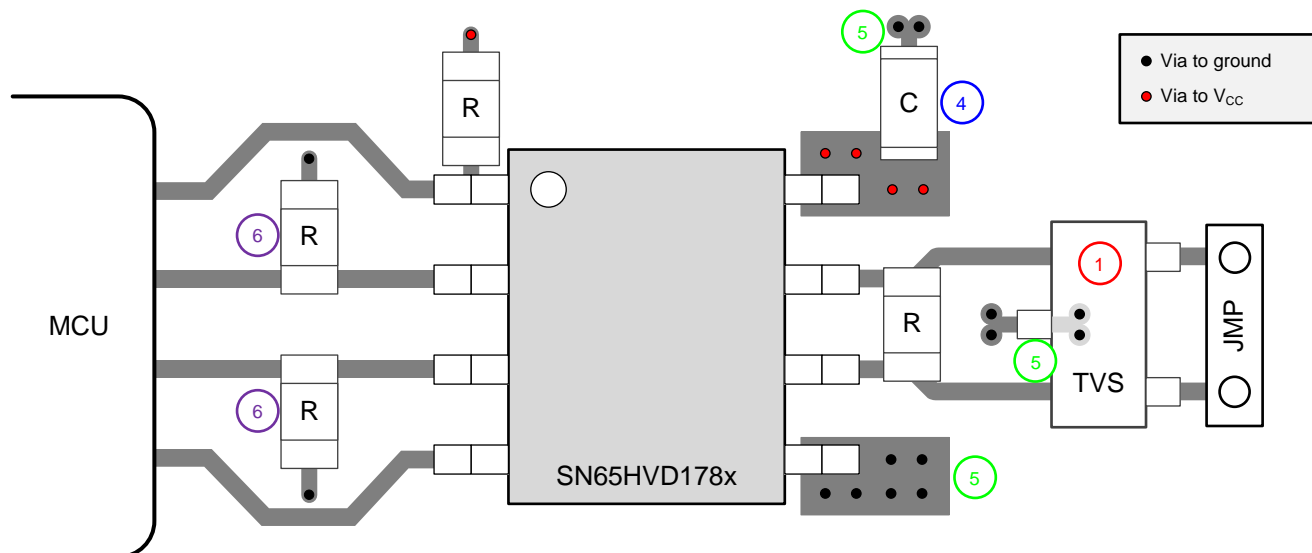

**Figure 20. Half-Duplex Layout Example**

## 12 Device and Documentation Support

### 12.1 Device Support

#### 12.1.1 Third-Party Products Disclaimer

TI'S PUBLICATION OF INFORMATION REGARDING THIRD-PARTY PRODUCTS OR SERVICES DOES NOT CONSTITUTE AN ENDORSEMENT REGARDING THE SUITABILITY OF SUCH PRODUCTS OR SERVICES OR A WARRANTY, REPRESENTATION OR ENDORSEMENT OF SUCH PRODUCTS OR SERVICES, EITHER ALONE OR IN COMBINATION WITH ANY TI PRODUCT OR SERVICE.

### 12.2 Documentation Support

#### 12.2.1 Related Documentation

For related documentation see the following:

- [RS-485 Half-Duplex Evaluation Module](#)
- [SN65HVD17xx Fault-Protected RS-485 Transceivers With Extended Common-Mode Range](#)
- [TPS7A6xxx-Q1 300-mA 40-V Low-Dropout Regulator With 25- \$\mu\$ A Quiescent Current](#)

#### 12.3 Receiving Notification of Documentation Updates

To receive notification of documentation updates, navigate to the device product folder on ti.com. In the upper right corner, click on *Alert me* to register and receive a weekly digest of any product information that has changed. For change details, review the revision history included in any revised document.

### 12.4 Community Resources

The following links connect to TI community resources. Linked contents are provided "AS IS" by the respective contributors. They do not constitute TI specifications and do not necessarily reflect TI's views; see TI's [Terms of Use](#).

**TI E2E™ Online Community** *TI's Engineer-to-Engineer (E2E) Community*. Created to foster collaboration among engineers. At e2e.ti.com, you can ask questions, share knowledge, explore ideas and help solve problems with fellow engineers.

**Design Support** *TI's Design Support* Quickly find helpful E2E forums along with design support tools and contact information for technical support.

### 12.5 Trademarks

E2E is a trademark of Texas Instruments.  
All other trademarks are the property of their respective owners.

### 12.6 Electrostatic Discharge Caution



This integrated circuit can be damaged by ESD. Texas Instruments recommends that all integrated circuits be handled with appropriate precautions. Failure to observe proper handling and installation procedures can cause damage.

ESD damage can range from subtle performance degradation to complete device failure. Precision integrated circuits may be more susceptible to damage because very small parametric changes could cause the device not to meet its published specifications.

### 12.7 Glossary

[SLYZ022](#) — *TI Glossary*.

This glossary lists and explains terms, acronyms, and definitions.

## 13 Mechanical, Packaging, and Orderable Information

The following pages include mechanical, packaging, and orderable information. This information is the most current data available for the designated devices. This data is subject to change without notice and revision of this document. For browser-based versions of this data sheet, refer to the left-hand navigation.

**PACKAGING INFORMATION**

Orderable Device	Status (1)	Package Type	Package Drawing	Pins	Package Qty	Eco Plan (2)	Lead/Ball Finish (6)	MSL Peak Temp (3)	Op Temp (°C)	Device Marking (4/5)	Samples
SN65HVD1780QDRQ1	ACTIVE	SOIC	D	8	2500	Green (RoHS & no Sb/Br)	CU NIPDAU	Level-1-260C-UNLIM	-40 to 125	1780Q	<a href="#">Samples</a>
SN65HVD1781QDRQ1	ACTIVE	SOIC	D	8	2500	Green (RoHS & no Sb/Br)	CU NIPDAU	Level-1-260C-UNLIM	-40 to 125	1781Q	<a href="#">Samples</a>
SN65HVD1782QDRQ1	ACTIVE	SOIC	D	8	2500	Green (RoHS & no Sb/Br)	CU NIPDAU	Level-1-260C-UNLIM	-40 to 125	1782Q	<a href="#">Samples</a>

(1) The marketing status values are defined as follows:

**ACTIVE:** Product device recommended for new designs.

**LIFEBUY:** TI has announced that the device will be discontinued, and a lifetime-buy period is in effect.

**NRND:** Not recommended for new designs. Device is in production to support existing customers, but TI does not recommend using this part in a new design.

**PREVIEW:** Device has been announced but is not in production. Samples may or may not be available.

**OBsolete:** TI has discontinued the production of the device.

(2) **RoHS:** TI defines "RoHS" to mean semiconductor products that are compliant with the current EU RoHS requirements for all 10 RoHS substances, including the requirement that RoHS substance do not exceed 0.1% by weight in homogeneous materials. Where designed to be soldered at high temperatures, "RoHS" products are suitable for use in specified lead-free processes. TI may reference these types of products as "Pb-Free".

**RoHS Exempt:** TI defines "RoHS Exempt" to mean products that contain lead but are compliant with EU RoHS pursuant to a specific EU RoHS exemption.

**Green:** TI defines "Green" to mean the content of Chlorine (Cl) and Bromine (Br) based flame retardants meet JS709B low halogen requirements of <=1000ppm threshold. Antimony trioxide based flame retardants must also meet the <=1000ppm threshold requirement.

(3) MSL, Peak Temp. - The Moisture Sensitivity Level rating according to the JEDEC industry standard classifications, and peak solder temperature.

(4) There may be additional marking, which relates to the logo, the lot trace code information, or the environmental category on the device.

(5) Multiple Device Markings will be inside parentheses. Only one Device Marking contained in parentheses and separated by a "-" will appear on a device. If a line is indented then it is a continuation of the previous line and the two combined represent the entire Device Marking for that device.

(6) Lead/Ball Finish - Orderable Devices may have multiple material finish options. Finish options are separated by a vertical ruled line. Lead/Ball Finish values may wrap to two lines if the finish value exceeds the maximum column width.

**Important Information and Disclaimer:** The information provided on this page represents TI's knowledge and belief as of the date that it is provided. TI bases its knowledge and belief on information provided by third parties, and makes no representation or warranty as to the accuracy of such information. Efforts are underway to better integrate information from third parties. TI has taken and continues to take reasonable steps to provide representative and accurate information but may not have conducted destructive testing or chemical analysis on incoming materials and chemicals. TI and TI suppliers consider certain information to be proprietary, and thus CAS numbers and other limited information may not be available for release.

In no event shall TI's liability arising out of such information exceed the total purchase price of the TI part(s) at issue in this document sold by TI to Customer on an annual basis.

**OTHER QUALIFIED VERSIONS OF SN65HVD1780-Q1, SN65HVD1781-Q1, SN65HVD1782-Q1 :**

- Catalog: [SN65HVD1780](#), [SN65HVD1781](#), [SN65HVD1782](#)

NOTE: Qualified Version Definitions:

- Catalog - TI's standard catalog product

## TAPE AND REEL INFORMATION



### QUADRANT ASSIGNMENTS FOR PIN 1 ORIENTATION IN TAPE



\*All dimensions are nominal

Device	Package Type	Package Drawing	Pins	SPQ	Reel Diameter (mm)	Reel Width W1 (mm)	A0 (mm)	B0 (mm)	K0 (mm)	P1 (mm)	W (mm)	Pin1 Quadrant
SN65HVD1780QDRQ1	SOIC	D	8	2500	330.0	12.4	6.4	5.2	2.1	8.0	12.0	Q1
SN65HVD1781QDRQ1	SOIC	D	8	2500	330.0	12.4	6.4	5.2	2.1	8.0	12.0	Q1
SN65HVD1782QDRQ1	SOIC	D	8	2500	330.0	12.4	6.4	5.2	2.1	8.0	12.0	Q1

**TAPE AND REEL BOX DIMENSIONS**

\*All dimensions are nominal

Device	Package Type	Package Drawing	Pins	SPQ	Length (mm)	Width (mm)	Height (mm)
SN65HVD1780QDRQ1	SOIC	D	8	2500	367.0	367.0	35.0
SN65HVD1781QDRQ1	SOIC	D	8	2500	367.0	367.0	35.0
SN65HVD1782QDRQ1	SOIC	D	8	2500	367.0	367.0	35.0

# D0008A

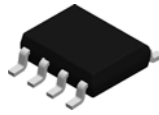

# PACKAGE OUTLINE

SOIC - 1.75 mm max height

SMALL OUTLINE INTEGRATED CIRCUIT

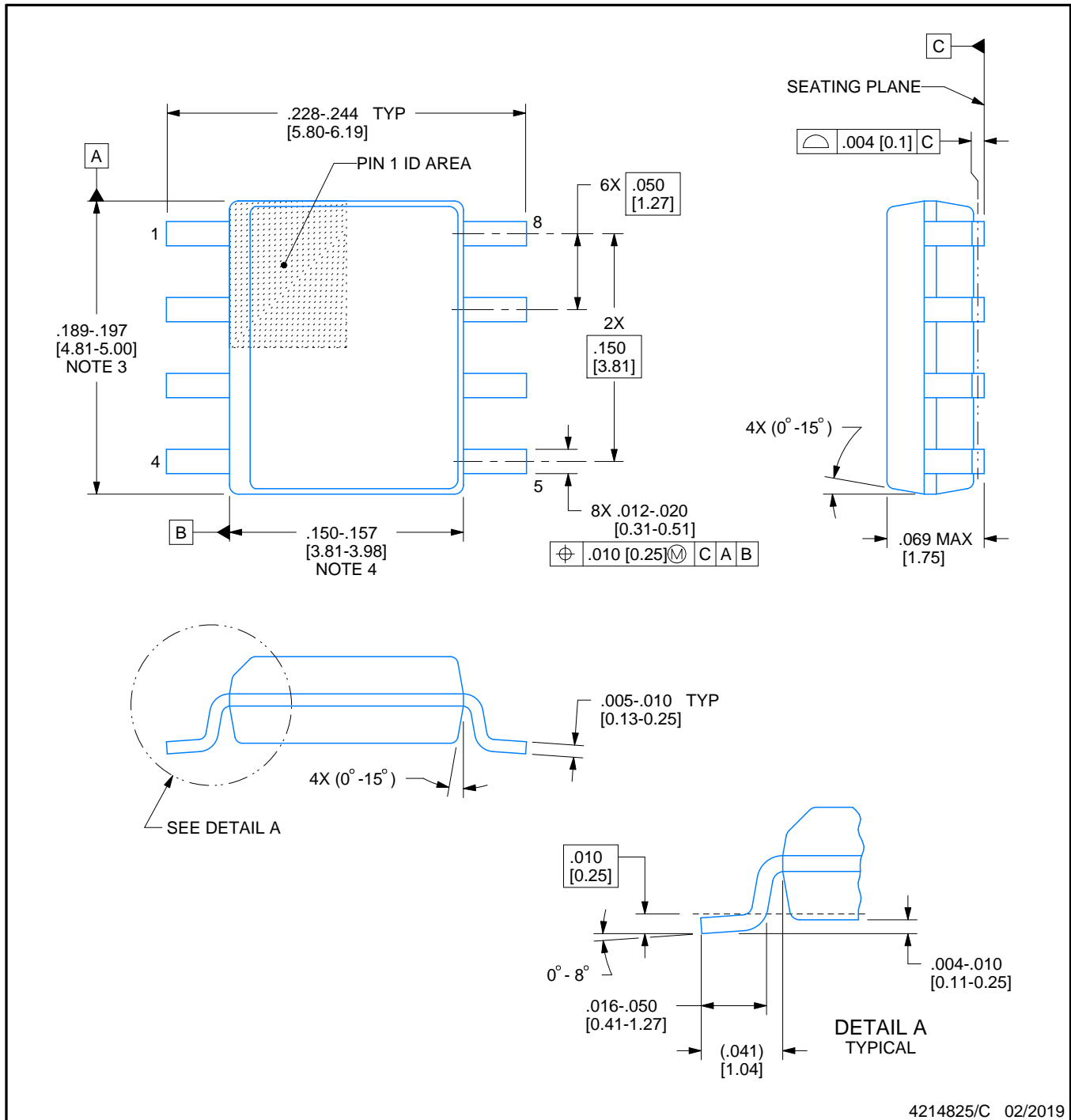

4214825/C 02/2019

## NOTES:

1. Linear dimensions are in inches [millimeters]. Dimensions in parenthesis are for reference only. Controlling dimensions are in inches. Dimensioning and tolerancing per ASME Y14.5M.
2. This drawing is subject to change without notice.
3. This dimension does not include mold flash, protrusions, or gate burrs. Mold flash, protrusions, or gate burrs shall not exceed  $.006$  [0.15] per side.
4. This dimension does not include interlead flash.
5. Reference JEDEC registration MS-012, variation AA.

# EXAMPLE BOARD LAYOUT

D0008A

SOIC - 1.75 mm max height

SMALL OUTLINE INTEGRATED CIRCUIT



LAND PATTERN EXAMPLE  
 EXPOSED METAL SHOWN  
 SCALE:8X



SOLDER MASK DETAILS

4214825/C 02/2019

NOTES: (continued)

- 6. Publication IPC-7351 may have alternate designs.
- 7. Solder mask tolerances between and around signal pads can vary based on board fabrication site.

# EXAMPLE STENCIL DESIGN

D0008A

SOIC - 1.75 mm max height

SMALL OUTLINE INTEGRATED CIRCUIT



SOLDER PASTE EXAMPLE  
BASED ON .005 INCH [0.125 MM] THICK STENCIL  
SCALE:8X

4214825/C 02/2019

NOTES: (continued)

8. Laser cutting apertures with trapezoidal walls and rounded corners may offer better paste release. IPC-7525 may have alternate design recommendations.
9. Board assembly site may have different recommendations for stencil design.

## IMPORTANT NOTICE AND DISCLAIMER

TI PROVIDES TECHNICAL AND RELIABILITY DATA (INCLUDING DATASHEETS), DESIGN RESOURCES (INCLUDING REFERENCE DESIGNS), APPLICATION OR OTHER DESIGN ADVICE, WEB TOOLS, SAFETY INFORMATION, AND OTHER RESOURCES "AS IS" AND WITH ALL FAULTS, AND DISCLAIMS ALL WARRANTIES, EXPRESS AND IMPLIED, INCLUDING WITHOUT LIMITATION ANY IMPLIED WARRANTIES OF MERCHANTABILITY, FITNESS FOR A PARTICULAR PURPOSE OR NON-INFRINGEMENT OF THIRD PARTY INTELLECTUAL PROPERTY RIGHTS.

These resources are intended for skilled developers designing with TI products. You are solely responsible for (1) selecting the appropriate TI products for your application, (2) designing, validating and testing your application, and (3) ensuring your application meets applicable standards, and any other safety, security, or other requirements. These resources are subject to change without notice. TI grants you permission to use these resources only for development of an application that uses the TI products described in the resource. Other reproduction and display of these resources is prohibited. No license is granted to any other TI intellectual property right or to any third party intellectual property right. TI disclaims responsibility for, and you will fully indemnify TI and its representatives against, any claims, damages, costs, losses, and liabilities arising out of your use of these resources.

TI's products are provided subject to TI's Terms of Sale ([www.ti.com/legal/termsofsale.html](http://www.ti.com/legal/termsofsale.html)) or other applicable terms available either on [ti.com](http://ti.com) or provided in conjunction with such TI products. TI's provision of these resources does not expand or otherwise alter TI's applicable warranties or warranty disclaimers for TI products.

Mailing Address: Texas Instruments, Post Office Box 655303, Dallas, Texas 75265  
Copyright © 2019, Texas Instruments Incorporated

## Looking for pricing, stock, or lifecycle information?

Click below to explore more details on WIN SOURCE:

 [View SN65HVD1781QDRQ1 on WIN SOURCE](#)

 [Texas Instruments](#) Information

## Optimize Your Supply Chain with WIN SOURCE Solutions

-  Global Sourcing Solution
-  Obsolete Management
-  Cost Control Management
-  Shortage Management
-  Alternative Solution
-  Excess Inventory Management