

---

**Embedded AVR Microcontroller Including RF Transmitter  
and Immobilizer LF Functionality for Remote Keyless  
Entry**

---

**DATASHEET**

---

**Features**

---

- System solution for immobilizer and remote keyless entry functionality
- Optional integrated open source immobilizer software stack supports automotive immobilizer applications (CMMI certified)
- Integrated ultra-low power flash Atmel® AVR® (8-bit) microcontroller
- 2112-byte EEPROM
- 32-bit unique device identification number
- Available in small 5x5 QFN32 pin package

---

**Contactless Transponder**

---

- LF contactless transponder operation in passive and active modes
- Integrated codecs for enhanced LF communication range
- Ultra low-power AES-128 cryptographic engine for use of immobilizer and RKE applications
- Access protected area for two 128-bit secret keys for device authentication
- Optional one 128-bit transport key for initial configuration
- LF receiver data integrity check (CRC-4/CRC-8)

---

**RF Transmitter**

---

- Fully integrated fractional-N PLL, VCO and loop filter covering 315MHz and 433MHz (software programmable)
- Output power programmable from -0.5 to +12.5dBm
- Supports ASK and FSK modulation with data rate up to 40Kbit/s
- Extended battery lifetime due to fast start-up time, low operating voltage and low supply current

**This is a summary document.  
The complete document is  
available under NDA. For more  
information, please contact  
your local Atmel sales office.**

## Ultra-low-power AVR Microcontroller

---

- 8Kbyte flash program memory (including 2KB of immobilizer software stack)
- 2112-byte EEPROM – includes protected user data and device configuration data (64Bytes)
- Error correction code (ECC) engine protects flash and EEPROM
- 512Bytes of SRAM
- Four GP timers
  - T0: Flexible WD and interval timers
  - T1: 15-bit interval timer
  - T2: Asynchronous 8-bit timer/counter with output compare
  - T3: Asynchronous 8-bit timer/counter with output compare and input capture
- Power management unit
- System clock management and monitoring functions
- POR and brown-out detection
- Programmable voltage monitor
- RTC and two internal system clock RC oscillators with  $f_1 = 125\text{kHz}$ ,  $f_2 = 4\text{MHz}$
- SPI, TW/SS1, IR digital interfaces; dW 1-wire debug IF with AVR development tools
- Very low power consumption:
  - Active:  $50\mu\text{A}$  (Sys\_Clk at 125kHz)
  - Idle:  $< 70\mu\text{A}$  (Sys\_Clk at 1MHz)
  - Power-down:  $0.8\mu\text{A}$
  - EE(wr):  $50\mu\text{A}$
- Wide battery voltage range from 1.9 to 3.6V (in contact mode)
- $-40$  to  $+85^\circ\text{C}$  operation temperature
- Automotive grade C compiler

# 1. Description

Atmel® ATA5795C is a smart remote keyless entry (RKE) device that includes an embedded ultra-low-power AVR® 8-bit microcontroller, a fractional-N RF transmitter and an LF immobilizer interface in a single QFN32 package.

Furthermore, the device has an integrated AES-128 cryptography hardware engine, which is accessible by both the immobilizer and the RKE unit. The immobilizer interface can run in contactless mode, allowing energy supply and data transmission via the LF link.

The Atmel ATA5795C is designed for automotive applications that necessitate both immobilization and remote keyless entry functions in one single key. It conforms to requirements of extremely low power consumption and provides all the necessary circuitry for the entire application.

## 1.1 System Block Diagram

Figure 1-1. System Block Diagram

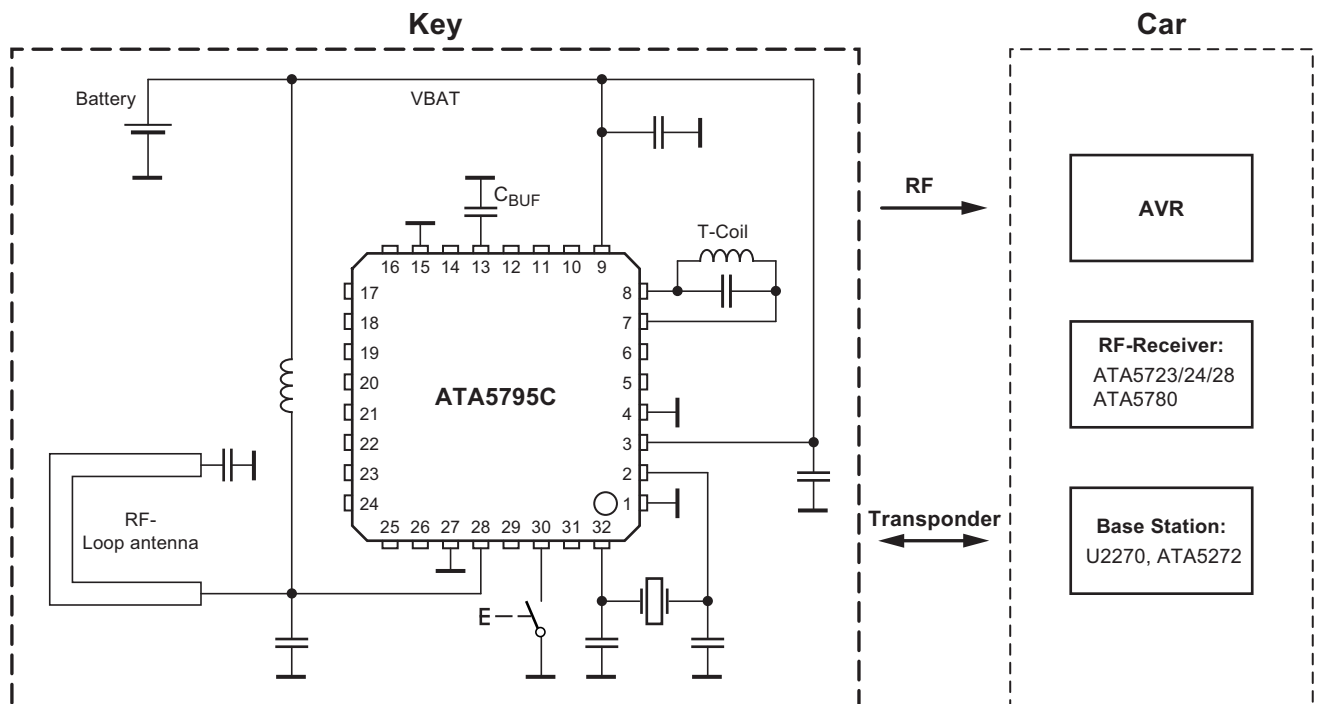

## 1.2 Atmel ATA5795C Block Diagram

Figure 1-2. Atmel ATA5795C Block Diagram

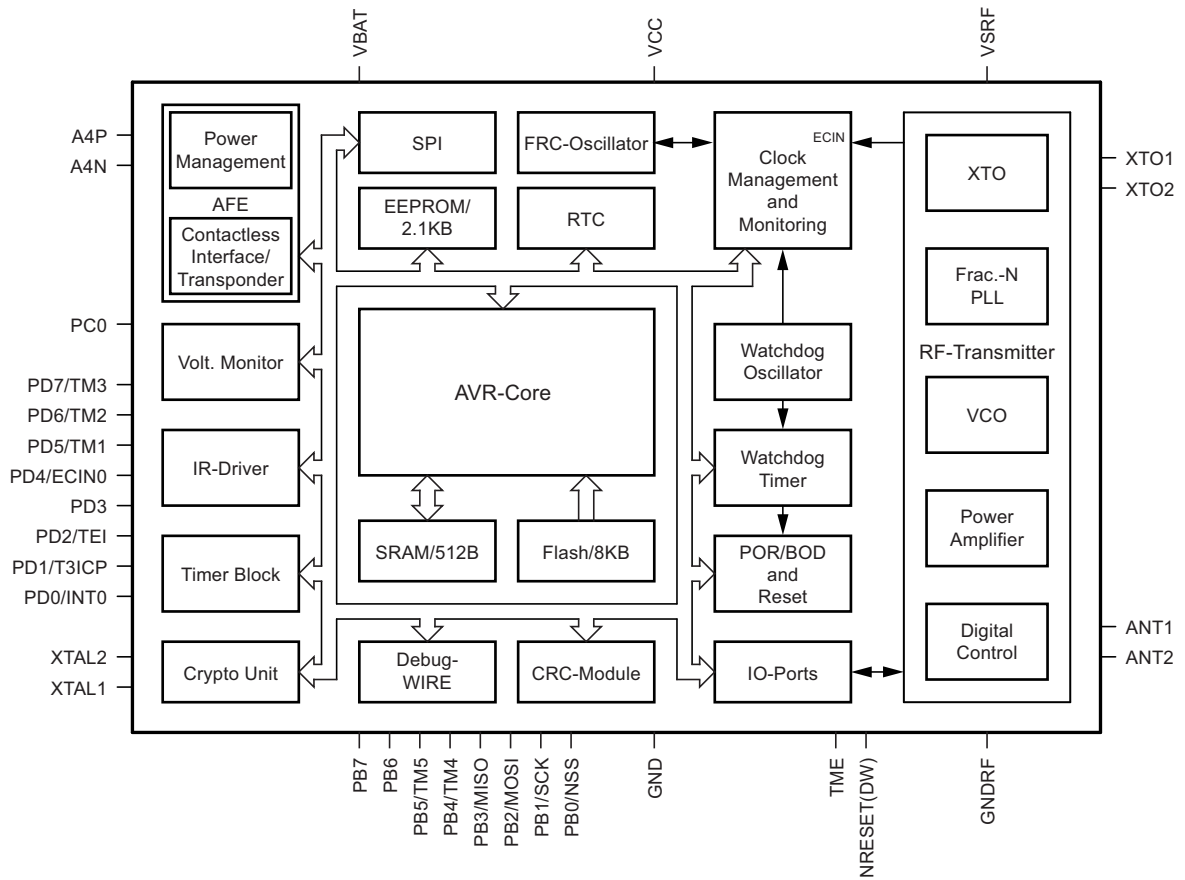

## 1.3 Pin Configurations

Figure 1-3. Pin Out for QFN 32 Package

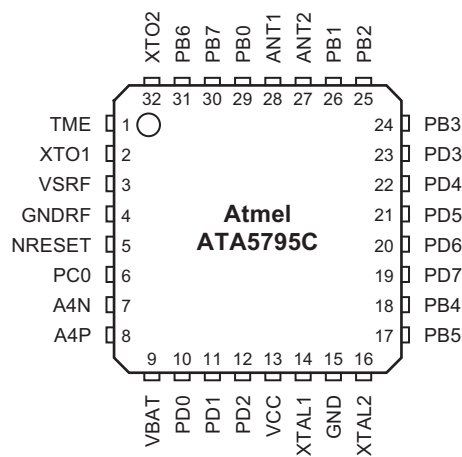

**Table 1-1. Pin Description**

Pin Number	Pin Name	Alternate Function 1	Alternate Function 2	Function	Comment
1	TME	-	-	Test mode enable	
2	XTO1	-	-	Connection for RF crystal	RF - pin
3	VSRF	-	-	Power supply voltage RF	RF - pin
4	GNDRF	-	-	Power supply ground RF	RF - pin
5	NRESET	dW	-	Reset input / debugWire interface	
6	PC0	-	-	I/O port	Port C0
7	A4N	-	-	Input pin for transponder AFE	
8	A4P	-	-	Input pin for transponder AFE	
9	VBAT	-	-	Power supply voltage for battery	
10	PD0	INT0	PCINT8	I/O port / external interrupt input 0	Port D0
11	PD1	T3ICP	PCINT9	I/O port / timer 3 external capture input	Port D1
12	PD2	TEI	PCINT10	I/O port / external timer input clock	Port D2
13	VCC	-	-	Power supply voltage for the microcontroller. A capacitor with capacitance $C_{BUF}$ must be connected at this pin to buffer the voltage during field supply and block the microcontroller VCC.	
14	XTAL1	-	-	32kHz crystal oscillator input pin	
15	GND	-	-	Power supply ground	
16	XTAL2	-	-	32kHz crystal oscillator output pin	
17	PB5	TM5	PCINT5	I/O port / timer modulator pin 5	Port B5
18	PB4	TM4	PCINT4	I/O port / timer modulator pin 4	Port B4
19	PD7	TM3	PCINT15	I/O port / timer modulator pin 3	Port D7
20	PD6	TM2	PCINT14	I/O port / timer modulator pin 2	Port D6
21	PD5	TM1	PCINT13	I/O port / timer modulator pin 1	Port D5
22	PD4	ECIN0	PCINT12	I/O port / external clock input 0	Port D4
23	PD3	-	PCINT11	I/O port	Port D3
24	PB3	MISO	PCINT3	I/O port / SPI	Port B3
25	PB2	MOSI	PCINT2	I/O port / SPI	Port B2
26	PB1	SCK	PCINT1	I/O port / SPI	Port B1
27	ANT2	-	-	RF antenna 2	RF - pin
28	ANT1	-	-	RF antenna 1	RF - pin
29	PB0	NSS	PCINT0	I/O port / SPI	Port B0
30	PB7	-	PCINT7	I/O port	Port B7
31	PB6	-	PCINT6	I/O port	Port B6
32	XTO2	-	-	Connection for RF crystal	RF - pin

## 2. Ordering Information

Extended Type Number	Package	Remarks
ATA5795C-PNQW	QFN32 - 5x5	Pb-free, 6k

## 3. Package Information

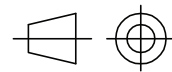
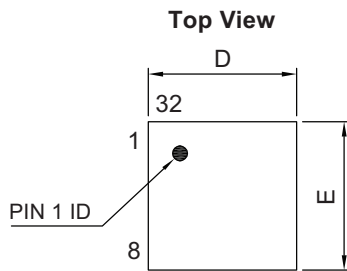

technical drawings  
according to DIN  
specifications

Dimensions in mm

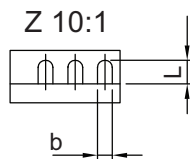
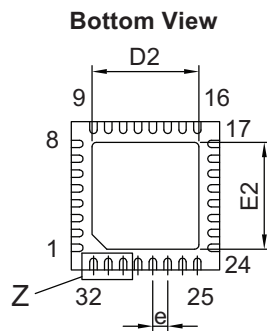
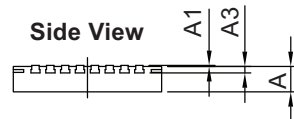

COMMON DIMENSIONS				
(Unit of Measure = mm)				
Symbol	MIN	NOM	MAX	NOTE
A	0.8	0.85	0.9	
A1	0	0.035	0.05	
A3	0.16	0.21	0.26	
D	4.9	5	5.1	
D2	3.5	3.6	3.7	
E	4.9	5	5.1	
E2	3.5	3.6	3.7	
L	0.35	0.4	0.45	
b	0.2	0.25	0.3	
e		0.5		

05/20/14



Package Drawing Contact:  
packagedrawings@atmel.com

TITLE  
Package: QFN\_5x5\_32L  
Exposed pad 3.6x3.6

GPC

DRAWING NO.  
6.543-5203.01-4

REV.  
1

## 4. Revision History

Please note that the following page numbers referred to in this section refer to the specific revision mentioned, not to this document.

Revision No.	History
9182ES-RKE-11/14	<ul style="list-style-type: none"><li>• Section 2 “Ordering Information” on page 6 updated</li><li>• Section 3 “Package Information” on page 6 updated</li></ul>
9182DS-RKE-04/14	<ul style="list-style-type: none"><li>• Put datasheet in the latest template</li></ul>
9182CS-RKE-11/11	<ul style="list-style-type: none"><li>• ATA5795 to ATA5795C renamed</li></ul>
9182BS-RKE-07/11	<ul style="list-style-type: none"><li>• Document completely redesigned</li></ul>

Atmel®, Atmel logo and combinations thereof, Enabling Unlimited Possibilities®, AVR®, and others are registered trademarks or trademarks of Atmel Corporation or its subsidiaries. Other terms and product names may be trademarks of others.

DISCLAIMER: The information in this document is provided in connection with Atmel products. No license, express or implied, by estoppel or otherwise, to any intellectual property right is granted by this document or in connection with the sale of Atmel products. EXCEPT AS SET FORTH IN THE ATMEL TERMS AND CONDITIONS OF SALES LOCATED ON THE ATMEL WEBSITE, ATMEL ASSUMES NO LIABILITY WHATSOEVER AND DISCLAIMS ANY EXPRESS, IMPLIED OR STATUTORY WARRANTY RELATING TO ITS PRODUCTS INCLUDING, BUT NOT LIMITED TO, THE IMPLIED WARRANTY OF MERCHANTABILITY, FITNESS FOR A PARTICULAR PURPOSE, OR NON-INFRINGEMENT. IN NO EVENT SHALL ATMEL BE LIABLE FOR ANY DIRECT, INDIRECT, CONSEQUENTIAL, PUNITIVE, SPECIAL OR INCIDENTAL DAMAGES (INCLUDING, WITHOUT LIMITATION, DAMAGES FOR LOSS AND PROFITS, BUSINESS INTERRUPTION, OR LOSS OF INFORMATION) ARISING OUT OF THE USE OR INABILITY TO USE THIS DOCUMENT, EVEN IF ATMEL HAS BEEN ADVISED OF THE POSSIBILITY OF SUCH DAMAGES. Atmel makes no representations or warranties with respect to the accuracy or completeness of the contents of this document and reserves the right to make changes to specifications and products descriptions at any time without notice. Atmel does not make any commitment to update the information contained herein. Unless specifically provided otherwise, Atmel products are not suitable for, and shall not be used in, automotive applications. Atmel products are not intended, authorized, or warranted for use as components in applications intended to support or sustain life.

SAFETY-CRITICAL, MILITARY, AND AUTOMOTIVE APPLICATIONS DISCLAIMER: Atmel products are not designed for and will not be used in connection with any applications where the failure of such products would reasonably be expected to result in significant personal injury or death ("Safety-Critical Applications") without an Atmel officer's specific written consent. Safety-Critical Applications include, without limitation, life support devices and systems, equipment or systems for the operation of nuclear facilities and weapons systems. Atmel products are not designed nor intended for use in military or aerospace applications or environments unless specifically designated by Atmel as military-grade. Atmel products are not designed nor intended for use in automotive applications unless specifically designated by Atmel as automotive-grade.

## Looking for pricing, stock, or lifecycle information?

Click below to explore more details on WIN SOURCE:

- ⊖ [View ATA5795C-PNQW 18 on WIN SOURCE](#)
- ⊖ [Microchip Technology](#) Information

## Optimize Your Supply Chain with WIN SOURCE Solutions

- ✓ Global Sourcing Solution
- ✓ Obsolete Management
- ✓ Cost Control Management
- ✓ Shortage Management
- ✓ Alternative Solution
- ✓ Excess Inventory Management